

Industrial Wireless Access Point

IAP-W510 / W512 User's Manual



Version 1.0
Oct, 2010.



ORing Industrial Networking Corp.

4F, NO.3, Lane235, Baociao Rd. Sindian City,

Taipei County 23145 Taiwan, R.O.C.

Tel: + 886 2 2918 3036

Fax: + 886 2 2918 3084

Website: www.oring-networking.com

E-mail: support@oring-networking.com

Table of Content

Getting to Know Your Access Point	1
1.1 About the ORing Access Point.....	1
1.2 Software Features	1
1.3 Hardware Features.....	1
Hardware Installation	2
2.1 Pole Mounting Installation	2
2.2 Wall Mounting Installation	2
Hardware Overview	3
3.1 Front Panel.....	3
3.2 Front Panel LEDs	4
Cables and Antenna	4
4.1 Ethernet Cables	4
4.2 100Base-T(X)/10Base-T Pin Assignments	5
4.3 Wireless Antenna.....	6
Management Interface	7
5.1 Explore IAP-W510 / W512.....	7
5.1.1 AP-Tool software.....	7
5.2 UPnP Equipment	8
5.3 Configuration by Web Browser	10

5.4	About Web-Based Management.....	10
5.5	Main Interface	11
5.5.1	Basic Setting.....	11
	Setting Operation Mode	11
	Setting WDS (Bridge Mode)	13
	Setting Wireless	17
	AP-Client/Client	23
	LAN Setting	24
	Setting DHCP Server	26
5.5.2	Advanced Setting.....	27
	Wireless.....	27
	X-Roaming	30
	MAC Filter	31
	System Event.....	32
	Email Settings.....	33
	SNMP Settings.....	33
	Syslog Server Settings.....	34
5.5.3	System Tools	35
	Administrator.....	35
	Date & Time	37
	Configuration.....	38
	Firmware Upgrade	39
	Miscellaneous	39
5.5.4	System Status.....	40
	System Info	40
	System Log.....	41
	Traffic Statistics	41

Wireless Clients	42
5.5.5 Online Help	42
Technical Specifications.....	43
APPENDIX A.....	45
How to configure SNMP MIB and use SNMP in the PCs?.....	45

Getting to Know Your Access Point

1.1 About the ORing Access Point

IAP-W510 / W512 are reliable IEEE802.11a/n WLAN Access Point with 1 Ethernet LAN port. It can be configured to operate in AP / Bridge / Repeater / AP-Client / Client mode. You can configure IAP-W510 / W512 by Window Utility or WEB interfaces via LAN port or WLAN interface. Therefore, IAP-W510 / W512 are one of the best communication solutions for wireless application.



1.2 Software Features

- High Speed Air Connectivity: WLAN interface support up to 300Mbps link speed connection
- Highly Security Capability: WEP/WPA/WPA2/WPA2-PSK/802.1x supported
- Support AP/Bridge/Repeater/AP-Client/Client Mode
- Secured Management by HTTPS
- Event Warning by Syslog, Email, SNMP Trap
- Support X-Roaming < 100 ms

1.3 Hardware Features

- Wider Power Inputs: 12~68 VDC
- 10/100Base-T(X) Ethernet port
- Casing: IP-67
- Dimensions(W x D x H) : 162 mm(W)x 102 mm(D)x 58 mm(H) for IAP-W510;
162 mm(W)x 102 mm(D)x 48 mm(H) for IAP-W512
- Operating Temperature: -30 to 70°C
- Storage Temperature: -30 to 85°C
- Operating Humidity: 100% non-condensing

Hardware Installation

2.1 Pole Mounting Installation

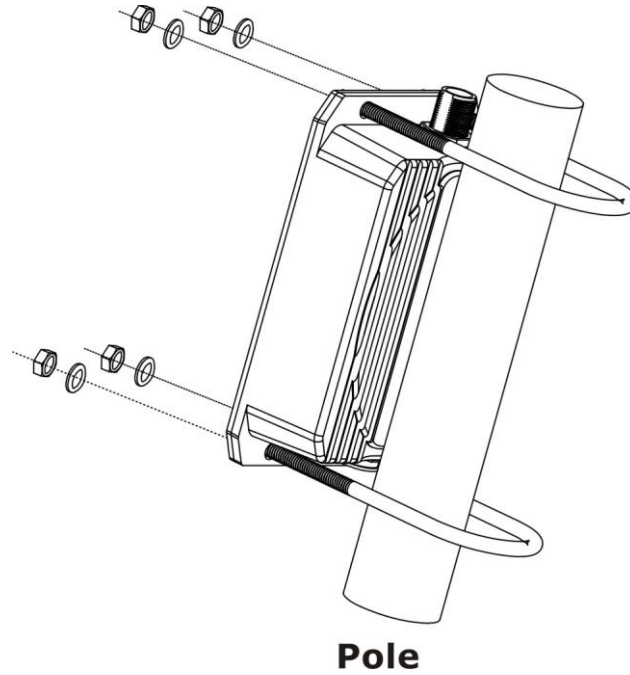

2.2 Wall Mounting Installation

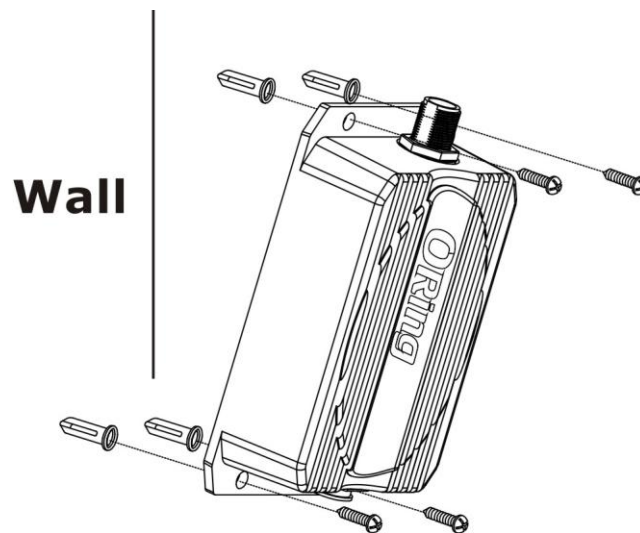

Hardware Overview

3.1 Front Panel

The following table describes the labels that stick on the IAP-W510 / W512.

Port	Description
10/100 RJ-45 fast Ethernet ports	10/100Base-T(X) RJ-45 fast Ethernet ports support auto-negotiation. Speed: auto
ANT.	2 x External N-type antenna connector for IAP-W512, Build-in 15dBi panel antenna for IAP-W510

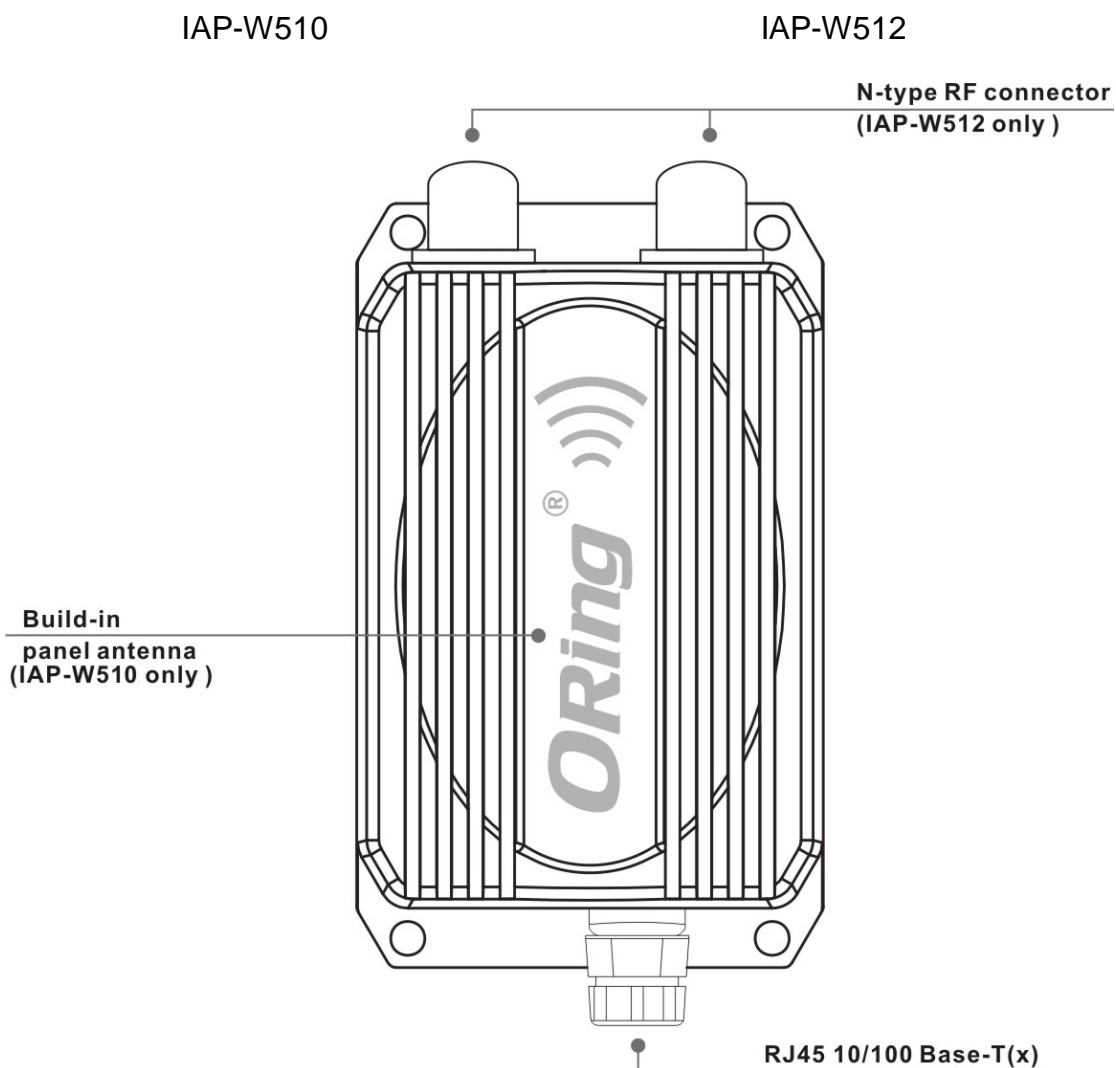

3.2 Front Panel LEDs

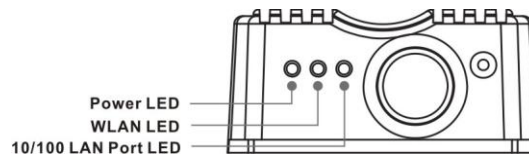

LED	Color	Status	Description
Power LED	Green	Green On	Power activated
WLAN LED	Green	Green On	WLAN activated.
LAN Port LED	Green	Green On	Port link up
		Green blinking	Data transmitted.

Cables and Antenna

4.1 Ethernet Cables

The IAP-W510 / W512 WLAN AP have standard Ethernet ports. According to the link type, the AP use CAT 3, 4, 5,5e UTP cables to connect to any other network device (PCs, servers, switches, routers, or hubs). Please refer to the following table for cable specifications.

Cable Types and Specifications

Cable	Type	Max. Length	Connector
10Base-T	Cat. 3, 4, 5 100-ohm	UTP 100 m (328 ft)	RJ-45
100Base-T(X)	Cat. 5 100-ohm UTP	UTP 100 m (328 ft)	RJ-45

4.2 100Base-T(X)/10Base-T Pin Assignments

With 100Base-T(X)/10Base-T cable, pins 1 and 2 are used for transmitting data, and pins 3 and 6 are used for receiving data.

RJ-45 Pin Assignments

Pin Number	Assignment
1	TD+
2	TD-
3	RD+
4	Not used
5	Not used
6	RD-
7	Not used
8	Not used

The IAP-510 / 512 AP support auto MDI/MDI-X operation. You can use a straight-through cable to connect PC and AP. The following table below shows the 10Base-T/100Base-T(X) MDI and MDI-X port pin outs.

MDI/MDI-X pins assignment

Pin Number	MDI port	MDI-X port
1	TD+(transmit)	RD+(receive)
2	TD-(transmit)	RD-(receive)
3	RD+(receive)	TD+(transmit)
4	Not used	Not used
5	Not used	Not used
6	RD-(receive)	TD-(transmit)
7	Not used	Not used
8	Not used	Not used

Note: "+" and "-" signs represent the polarity of the wires that make up each wire pair.



4.3 Wireless Antenna

2 x External N-type antenna connector for IAP-W512, Build-in 15dBi panel antenna for IAP-W510

Management Interface

5.1 Explore IAP-W510 / W512

5.1.1 AP-Tool software

Each model contains friendly software, AP-Tool, to explore IAP-W510 / W512 on local area network.

Step 1: Open the AP tool and click "Refresh list", the AP devices will show on the list.

Step 2: Choose your access point, and it will show the AP attribute. Simultaneity, you can manual set the AP's IP address.

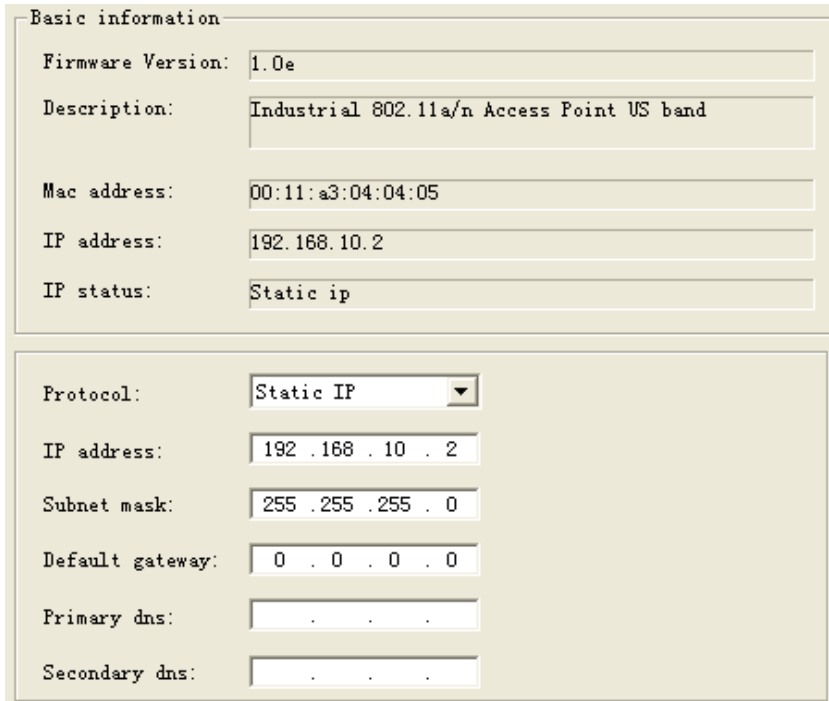

The screenshot displays the AP-Tool configuration window, divided into two sections. The top section, titled "Basic information", contains the following fields:

Firmware Version:	1.0e
Description:	Industrial 802.11a/n Access Point US band
Mac address:	00:11:a3:04:04:05
IP address:	192.168.10.2
IP status:	Static ip

The bottom section contains network configuration fields:

Protocol:	Static IP
IP address:	192 . 168 . 10 . 2
Subnet mask:	255 . 255 . 255 . 0
Default gateway:	0 . 0 . 0 . 0
Primary dns:	. . .
Secondary dns:	. . .

User interface of AP-Tool

Step 3: Click "Access via web" button, it will go to web page.

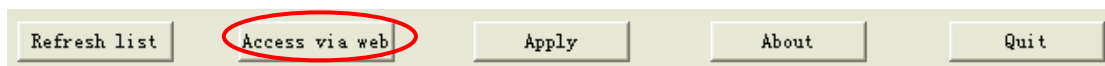

5.2 UPnP Equipment

Step 1: To check whether the UPnP UI of the computer is connected to the IAP-W510 / W512, go to **Control Panel > Add or Remove Programs > Windows Components Wizard > Networking Servers > UPnP User Interface** and pitch on the UPnP User Interface.

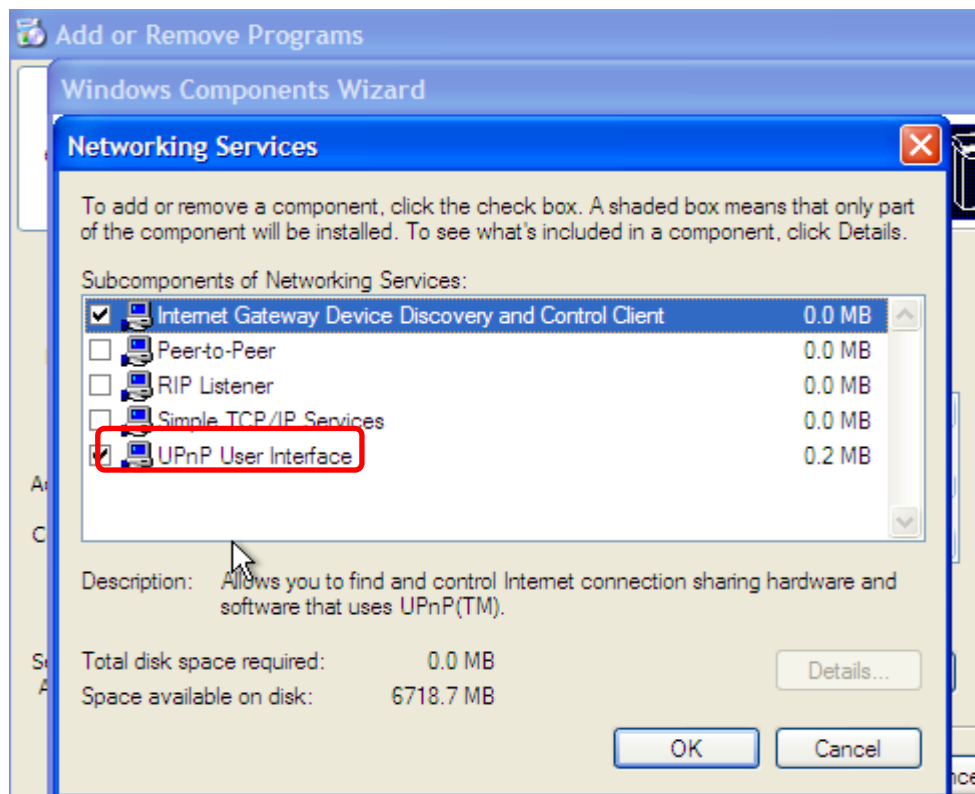

UPnP configuration page

Step 2: At the right-below corner of the computer, you will find a sign of the UPnP equipment.

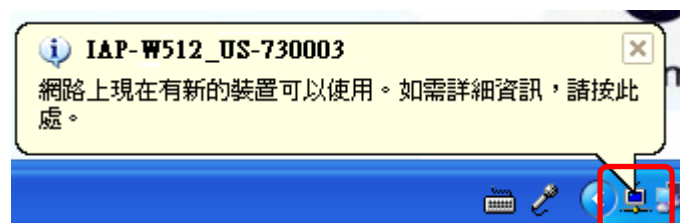

Step 3: Click the sign of the UPnP equipment, then you will find the UPnP equipment in the network neighborhood.



5.3 Configuration by Web Browser

This section introduces the configuration by Web browser.

5.4 About Web-Based Management

An embedded HTML web site resides in flash memory in the system. It contains advanced management features and allows you to manage the AP from anywhere on the network through a standard web browser such as Microsoft Internet Explorer.

The Web-Based Management function supports Internet Explorer 5.0 or later. It is Based on Java Applets with an aim to reduce network bandwidth consumption, enhance access speed and present an easy viewing screen.

Note: By default, IE5.0 or later version does not allow Java Applets to open sockets. You need to explicitly modify the browser setting in order to enable Java Applets to use network ports.

Through the front section's information, you will see as following, enter your user name and your password, then click **OK** to continue. If it is the first time to set up configuration, the default user name and password are "admin."

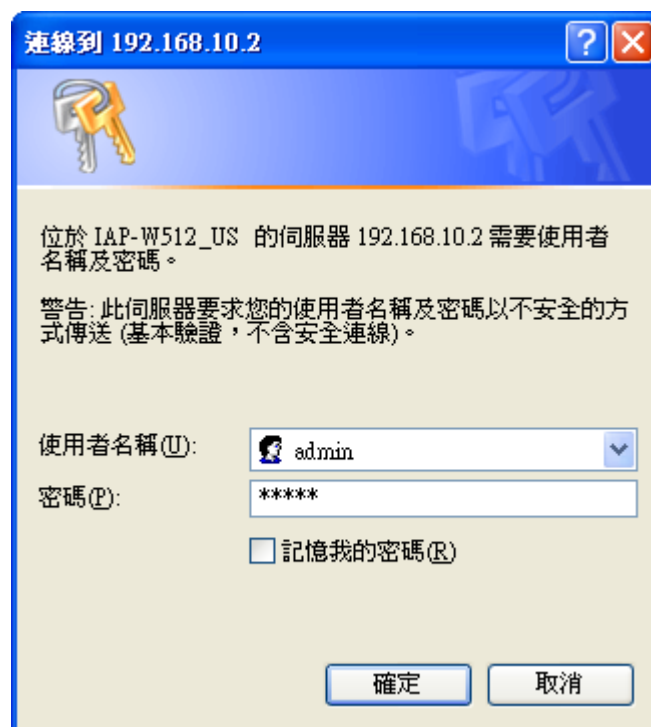

Login screen

Note: For security reasons, we strongly suggest you change the password. Click on

System Tools > Administrator and modify the password.

5.5 Main Interface

The **Home** screen will appear. Please click “Run Wizard” to go to the **Home > Setup Wizard** page to quick install the AP.

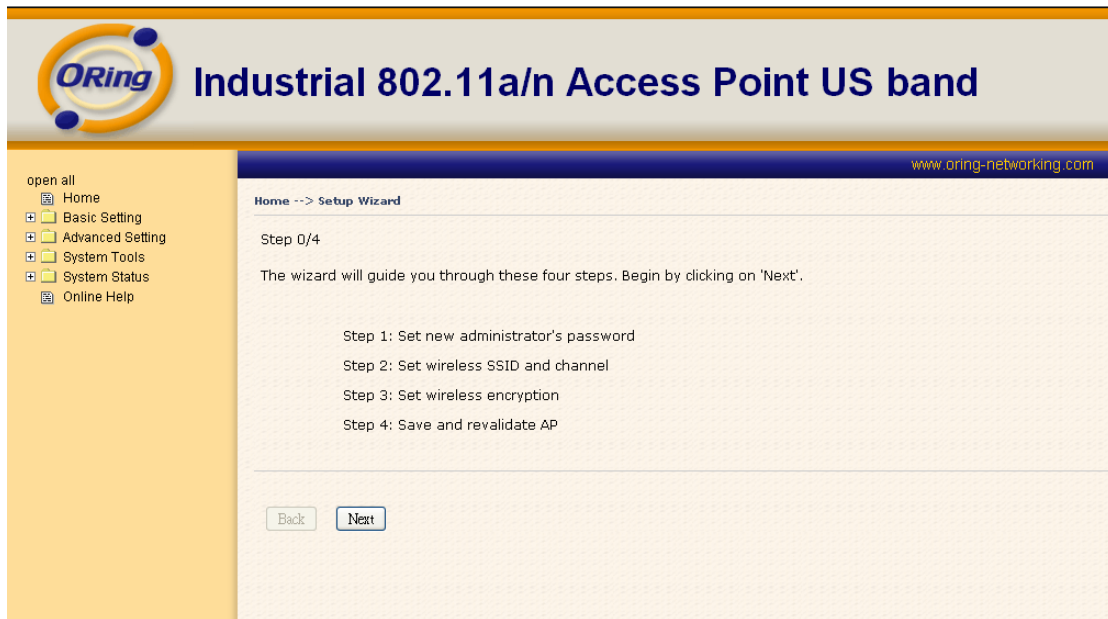

Main interface

5.5.1 Basic Setting

Setting Operation Mode

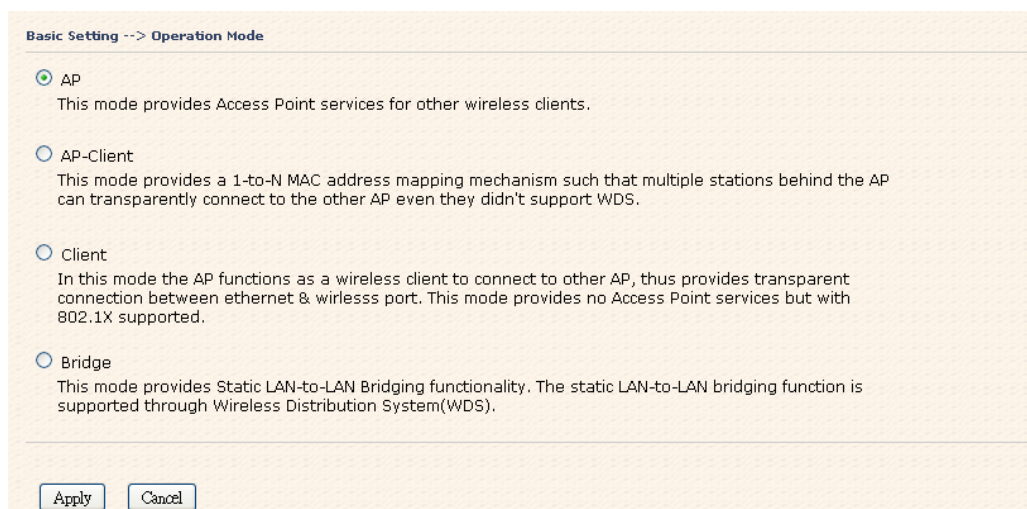

Operation mode interface

The following table describes the labels in this screen.

Label	Description
AP	This mode provides Access Point services for other wireless clients.
AP-Client	The AP-Client function provides a 1-to-N MAC address mapping mechanism such that multiple stations behind the AP can transparently connect to the other AP even they didn't support WDS.
Client	In this mode the AP functions as a wireless client to connect to other AP, thus provides transparent connection between Ethernet & wireless port. This mode provides no Access Point services but with 802.1X supported.
Bridge	This mode provides Static LAN-to-LAN Bridging functionality. The static LAN-to-LAN bridging function is supported through Wireless Distribution System (WDS).

In each mode, the IAP-W510 / W512 forwards packet between its Ethernet interface and wireless interface for wired hosts on the Ethernet side, and wireless hosts on the wireless side.

Setting WDS (Bridge Mode)

Basic Setting --> WDS

Operation mode of the AP should be set to "Bridge" mode before these settings changed.

WDS Mode:

Peer Mac Address 1: Enabled

Peer Mac Address 2: Enabled

Peer Mac Address 3: Enabled

Peer Mac Address 4: Enabled

WDS setting interface

The following table describes the labels in this screen.

Label	Description
WDS Mode	This mode provides Static LAN-to-LAN Bridging functionality. The static LAN-to-LAN bridging function is supported through Wireless Distribution System (WDS).
Peer MAC Address	Set the Mac address(es) of other access point(s). Simultaneity, choose on "Enable".

This type of wireless link is established between two IEEE 802.11 access points. Wireless packets transmitted along the WDS link comply with the IEEE 802.11 WDS (Wireless Distribution System) format at the link layer.

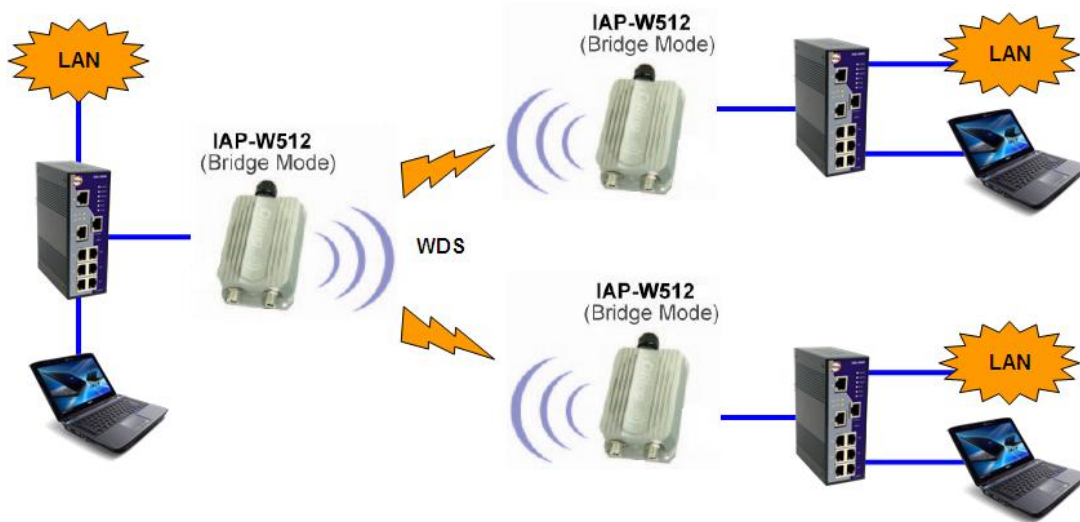

Point-to-Multipoint WDS Link

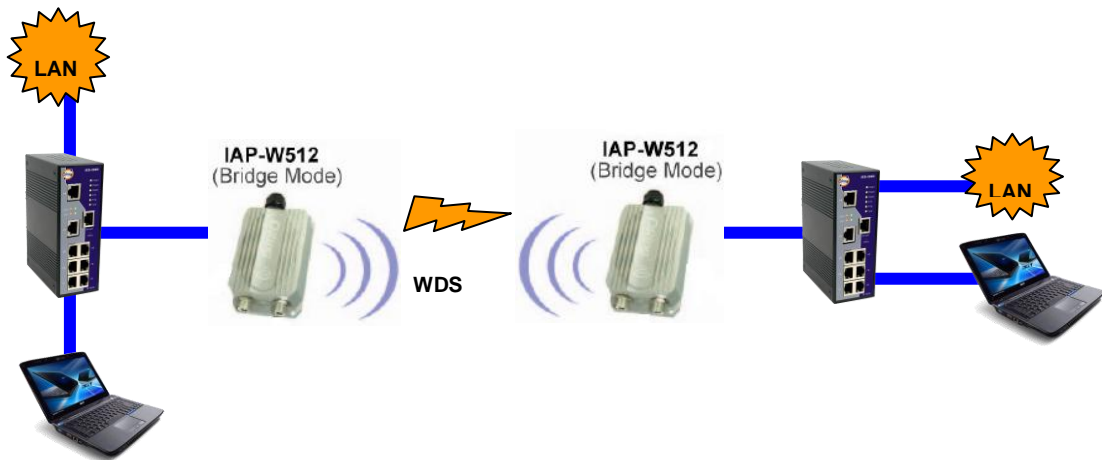

Point-to-Point WDS Link

First of all, if APs link with WDS mode, it should obey the following rules:

1. LAN IP Address should set different IP in the same network.
2. All AP's DHCP Server should set shutdown.
3. WDS should set Enable.
4. Each AP should have the same setting except 'Peer Mac Address' set to the other's Mac address

5. WEP Key and Channel should be the same, and each AP's SSID should be broadcast to see in the other's computer.
6. AP's distance should limit to a certainty area.

WDS – Restricted Mode

Basic Setting --> WDS

Operation mode of the AP should be set to "Bridge" mode before these settings changed.

WDS Mode: Restricted Mode

Peer Mac Address 1:	<input type="text" value="aa:bb:cc:dd:ee:ff"/>	<input checked="" type="checkbox"/> Enabled
Peer Mac Address 2:	<input type="text"/>	<input type="checkbox"/> Enabled
Peer Mac Address 3:	<input type="text"/>	<input type="checkbox"/> Enabled
Peer Mac Address 4:	<input type="text"/>	<input type="checkbox"/> Enabled

The peer WDS APs are according to the MAC address listed in "Peer Mac Address" fields.

WDS –Bridge Mode

Basic Setting --> WDS

Operation mode of the AP should be set to "Bridge" mode before these settings changed.

WDS Mode: Bridge Mode

Peer Mac Address 1:	<input type="text" value="aa:bb:cc:dd:ee:ff"/>	<input checked="" type="checkbox"/> Enabled
Peer Mac Address 2:	<input type="text"/>	<input type="checkbox"/> Enabled
Peer Mac Address 3:	<input type="text"/>	<input type="checkbox"/> Enabled
Peer Mac Address 4:	<input type="text"/>	<input type="checkbox"/> Enabled

Same as Restrict mode in functionality and also one WDS link side can not set **Peer Mac Address 1-4**.

The working principle of **Bridge Mode** as following:

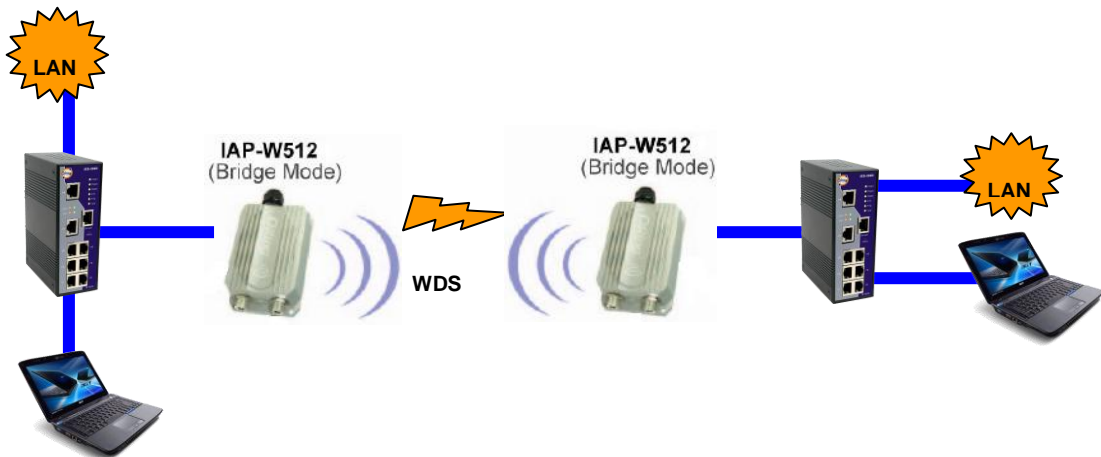

In the figure, the AP behaves as a standard bridge that forwards traffic between WDS links (links that connect to other AP/wireless bridges) and an Ethernet port. As a standard bridge, the AP learns MAC addresses of up to 64 wireless or 128 total wired and wireless network devices, which are connected to their respective Ethernet ports to limit the amount of data to be forwarded. Only data destined for stations which are known to reside on the peer Ethernet link, multicast data or data with unknown destinations need to be forwarded to the peer AP via the WDS link.

WDS –Repeater Mode

Basic Setting --> WDS

Operation mode of the AP should be set to "Bridge" mode before these settings changed.

WDS Mode: Repeater Mode

Peer Mac Address 1:	aa:bb:cc:dd:ee:ff	<input checked="" type="checkbox"/> Enabled
Peer Mac Address 2:		<input type="checkbox"/> Enabled
Peer Mac Address 3:		<input type="checkbox"/> Enabled
Peer Mac Address 4:		<input type="checkbox"/> Enabled

Same as Restrict mode in functionality and also one WDS link side can not set **Peer Mac Address 1-4**.

The working principle of **Repeater Mode** as follows:

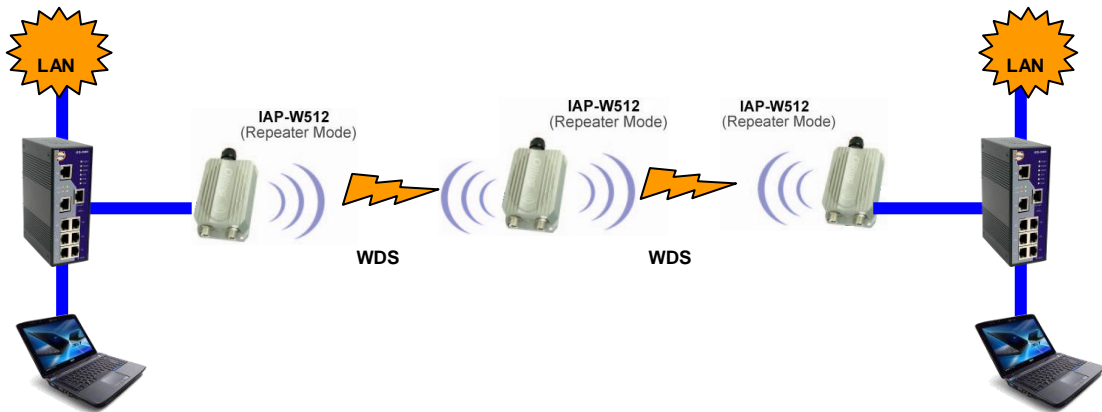

In the figure, Repeater is used to extend the range of the wireless infrastructure by forwarding traffic between associated wireless stations and another repeater or AP connected to the wired LAN.

Setting Wireless

The screenshot shows the 'Basic Setting --> Wireless' configuration page. The title is 'Basic Setting --> Wireless'. Below the title, it says 'Basic wireless settings for the AP.' The configuration includes:

- SSID: oring
- Channel: 6
- Radio Button: OFF
- Security Options: Security Type dropdown menu with options: None, WEP, WPA-PSK/WPA2-PSK, WPA/WPA2, 802.1X.

 At the bottom, there are 'Apply' and 'Cancel' buttons.

The following table describes the labels in this screen.

Label	Description
SSID	Service Set Identifier Default is the default setting. The SSID is a unique name that identifies a network. All devices on the network must share the same SSID name in order to communicate on the network. If you change the SSID from the default setting, input your new SSID name in this field.



Channel	Channel Auto is the default channel, input a new number if you want to change the default setting. All devices on the network must be set to the same channel to communicate on the network.
Security options	Select the type of security for your wireless network at Security Type: None: Select for no security. WEP: Select for security WEP. WPA-PSK/WPA2-PSK: Select for security WPA-PSK or WPA2-PSK without a RADIUS server. WPA/WPA2: Select for WPA or WPA2 (Wi-Fi Protected Access) authentication in conjunction with a RADIUS server. 802.1x: Authentication through RADIUS server

Security Type – None

No security protection on your wireless LAN access.

Security Type – WEP

Basic Setting --> Wireless

These are the basic wireless settings for the AP.

SSID:

Channel:

Peer AP SSID: (Apply when 'AP-Client' mode selected)

Security Options

Security Type:

Auth Mode: Open Shared WEPAUTO

WEP Encryption:

Key Type:

Default Key Index:

KEY1:

KEY2:

KEY3:

KEY4:

1. Security Type: Select **WEP**
2. WEP Encryption: Select 64 Bit or 128 Bit WEP encryption.
3. Key Type: Select ASCII or Hex key type.
4. Default Key Index: Select one of the keys to be the active key.
5. Key 1-4: Input up to four encryption keys.

ASCII (American Standard Code for Information Interchange) is a code for representing English letters as numbers from 0-127. **Hex** digits consist of the numbers 0-9 and the letters A-F.

Security Type – WPA-PSK/WPA2-PSK

Basic Setting --> Wireless

These are the basic wireless settings for the AP.

SSID:

Channel:

Peer AP SSID: (Apply when 'AP-Client' mode selected)

Security Options

Security Type:

Auth Mode: WPAPSK WPA2PSK WPAPSK/WPA2PSK mix

Encryption Type: TKIP AES TKIP/AES mix

Shared Key: (8~64 characters)

1. Security Type: Select **WPA-PSK/WPA2-PSK**.
2. Encryption Type: Select **TKIP** or **AES** encryption.
3. Share Key: Enter your password. The password can be between 8 and 64 characters.

Security Type – WPA /WPA2

Basic Setting --> Wireless

These are the basic wireless settings for the AP.

SSID:

Channel:

Peer AP SSID: (Apply when 'AP-Client' mode selected)

Security Options

Security Type:

Auth Mode: WPA WPA2 WPA/WPA2 mix

Encryption Type: TKIP AES TKIP/AES mix

Radius Server IP: . . .

Radius Port:

Shared Secret:

1. Security Type: Select **WPA/WPA2**
2. Radius Server IP: Enter the IP address of the RADIUS Server.
3. Port: Enter the RADIUS port (1812 is default).

4. Shared Secret: Enter the RADIUS password or key.

Security Type – 802.1x

Basic Setting --> Wireless

Basic wireless settings for the AP.

SSID:

Channel:

Radio Button:

Security Options

Security Type:

Radius Server IP: . . .

Radius Port:

Shared Secret:

1. Security Type: Select **802.1x**
2. Radius Server IP: Enter the IP address of the RADIUS Server.
3. Port: Enter the RADIUS port (1812 is default).
4. Shared Secret: Enter the RADIUS password or key.

RADIUS (Remote Authentication Dial-in User Service) is the industrial standard agreement, and it is used to provide an identify verification. The Radius customer (is usually a dial-in server, VPN server or wireless point) send your proof and the conjunction parameter to the Radius server by Radius news. The Radius server validates the request of the Radius customer, and return Radius news to back.

Radius server validates your proof, also carry on the authorization. So the Radius server received by ISA server responded (point out the customer carries proof to be not granted) and it means that the Radius server did not authorize you to carry. Even if the proof has already passed an identity verification, the ISA server may also refuse you to carry a claim according to the authorization strategy of the Radius server.

The principle of the Radius server shows in the following pictures:

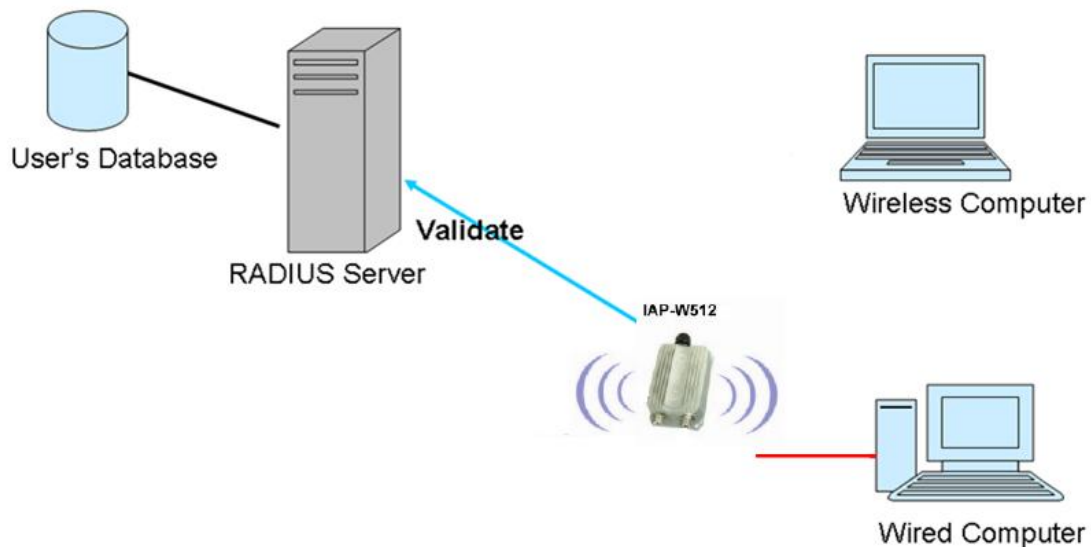

AP-Client/Client

The **Basic setting**—>**AP-Client/Client** page is mainly set the client which through the SSID and Security to connect to other AP. In this mode, the Security Type should be the same with the AP Server.

Basic Setting --> AP-Client/Client

AP-Client related settings.

Peer AP SSID:

Security Options

Security Type: (dropdown menu showing: None, WEP, WPA-PSK/WPA2-PSK)

The principle of the AP-Client/Client mode shows in the following pictures:

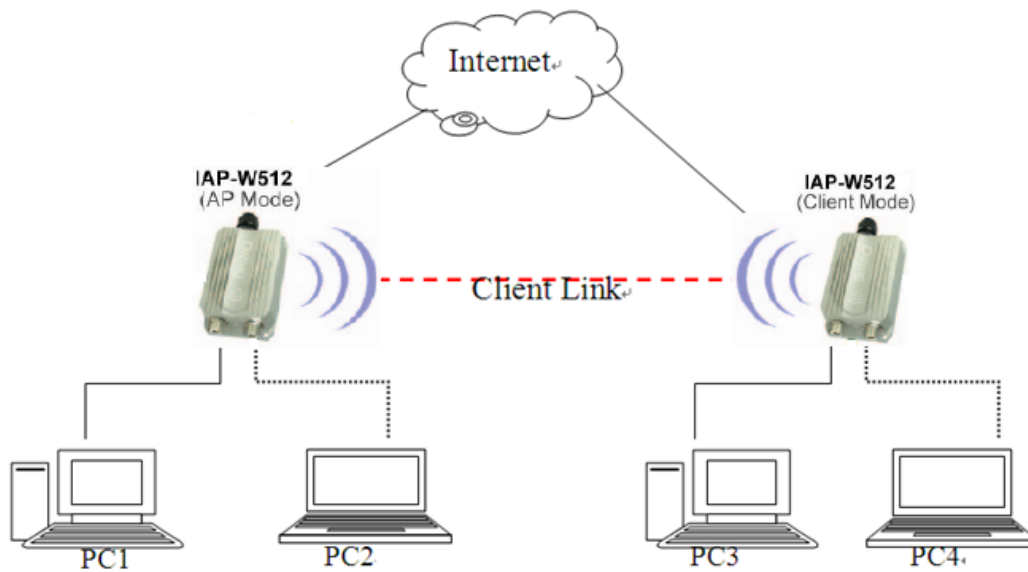

Result:

1. PC1, PC2 can visit PC3, PC4 and AP Client
2. PC3, PC4 can visit PC1, PC2 and AP
3. AP Client can visit AP

The following table describes the labels in this screen.

Label	Description
Peer AP SSID	Enter the other AP which used for AP mode.
Site Scan	You can scan the APs which used for AP mode in the certainty area
Security Type	Set the same security with the AP which you want to connect.

LAN Setting

The **Basic Setting > LAN Setting** page is mainly set IP address for LAN interface. To access the AP normally, a valid IP address of your LAN should be specified to the LAN interface. The default IP setting is DHCP server (Obtain an IP address automatically).

Basic Setting --> LAN Setting

LAN settings of AP.

Obtain an IP address automatically
 Use the following IP address

IP Address: . . .
 Subnet Mask: . . .
 Default Gateway: . . .

Obtain DNS server address automatically
 Use the following DNS server addresses

Preferred DNS: . . .
 Alternate DNS: . . .

Device Name:

Spanning Tree Protocol: Enable Disable
 LLDP Protocol: Enable Disable



The following table describes the labels in this screen.

Label	Description
Obtain an IP address automatically	Select this option if you would like to have an IP address automatically assigned to the IAP-W510 / W512 by DHCP server in your network
Use the following IP address	Select this option if you are manually assigning an IP address. IP Address: There is a default IP address in the AP, and you can input a new IP address. Subnet Mask: 255.255.255.0 is the default Subnet Mask. All devices on the network must have the same subnet mask to communicate on the network. Default Gateway: Enter the IP address of the router in your network.
Obtain DNS server address automatically	This option is selected by DHCP server.
Use the following DNS server addresses	This option is selected by manually set Preferred DNS: There is a default DNS server, and you can input another new DNS server. Alternate DNS: There is a default DNS server, and you can input another new DNS server.

Setting DHCP Server

Basic Setting --> DHCP Server

The AP can be setup as a DHCP server to distribute IP addresses to the WLAN network.

DHCP Server Enabled Disabled

Options

Starting IP address: . . .

Maximum Number of IPs:

Lease Time: hours

DHCP Clients List:

Hostname	Mac Address	IP Address	Expires In

The following table describes the labels in this screen.

Label	Description
DHCP Server	Enable or Disable the DHCP Server function. Enable – the AP will be the DHCP server on your local network
Start IP Address	The dynamic IP assign range. Low IP address is the beginning of the dynamic IP assigns range. For example: dynamic IP assign range is from 192.168.1.100 to 192.168.1.200. 192.168.1.100 will be the Start IP address.
Maximum Number of IPs	The dynamic IP assign range. High IP address is the end of the dynamic IP assigns range. For example: dynamic IP assign range is from 192.168.1.100 to 192.168.1.200. 100 will be enter into textbox.
Lease Time (Hour)	It is the time period that system will reset the dynamic IP assignment to ensure the dynamic IP will not been occupied for a long time or the server doesn't know that the dynamic IP is idle.
DHCP Clients List	List the devices on your network that are receiving dynamic IP addresses from the IAP-W510 / 512.

5.5.2 Advanced Setting

Wireless

Advanced Setting --> Wireless

Wireless performance tuning.

Beacon Interval: (msec, range:20~1024, default:100)

DTIM Interval: (range: 1~255, default:1)

Fragmentation Threshold: (range: 256~2346, default:2346)

RTS Threshold: (range: 1~2347, default:2347)

Xmit Power: % (range: 1~100, default:100)

Wireless Mode: A Mode A/N(5G) Mode N(5G) Mode

Preamble: Long Short

SSID Broadcast: Enabled Disabled

HT RDG: Disable Enable

HT Operating Mode: Mixed Mode Green Field

HT Extension Channel:

HT Band Width: 20 MHz 20/40 MHz

HT Auto BlockACK: Disable Enable

HT Decline BA Request: Disable Enable

HT Guard Interval: Long Short

HT MCS:

HT Aggregation MSDU: Disable Enable

HT TxStream:

HT RxStream:

The following table describes the labels in this screen.

Label	Description
Beacon Interval	The default value is 100. The Beacon Interval value indicates the frequency interval of the beacon. A beacon is a packet broadcast by the AP to synchronize the wireless network. 50 is recommended in poor reception.
DTIM Interval	The default value is 1. This value, between 1 and 255 milliseconds, indicates the interval of the Delivery Traffic Indication Message (DTIM). A DTIM field is a countdown field informing



	<p>clients of the next window for listening to broadcast and multicast messages. When the AP has buffered broadcast or multicast messages for associated clients, it sends the next DTIM with a DTIM Interval value. Its clients hear the beacons and awaken to receive the broadcast and multicast messages.</p>
Fragmentation Threshold	<p>This value should remain at its default setting of 2346. The range is 256-2346 bytes. It specifies the maximum size for a packet before data is fragmented into multiple packets. If you experience a high packet error rate, you may slightly increase the Fragmentation Threshold. Setting the Fragmentation Threshold too low may result in poor network performance. Only minor modifications of this value are recommended.</p>
RTS Threshold	<p>This value should remain at its default setting of 2347. The range is 0-2347 bytes. Should you encounter inconsistent data flow, only minor modifications are recommended. If a network packet is smaller than the preset RTS threshold size, the RTS/CTS mechanism will not be enabled. The AP sends Request to Send (RTS) frames to a particular receiving station and negotiates the sending of a data frame. After receiving an RTS, the wireless station responds with a Clear to Send (CTS) frame to acknowledge the right to begin transmission.</p>
Xmit Power	<p>This value ranges from 1 - 100 percent, default value is 100 percent. A safe increase of up to 60 percent would be suitable for most users. Higher power settings are not recommended for users due to excess heat generated by the radio chipset, which can affect the life of the AP.</p>



Wireless Network Mode	If you have 802.11N (5G) devices in your network, then keep the default setting, N (5G) mode. If you have only Wireless-A devices, select A Mode or A/N mix mode.
Transmission Rate	The default setting is Auto . The range is from 1 to 54Mbps. The rate of data transmission should be set depending on the speed of your wireless network. You can select from a range of transmission speeds, or keep the default setting, Auto, to have the AP automatically use the fastest possible data rate and enable the Auto-Fallback feature. Auto-Fallback will negotiate the best possible connection speed between the AP and a wireless client.
Preamble	Values are Long and Short, default value is Long. If your wireless device supports the short preamble and you are having trouble getting it to communicate with other 802.11b devices, make sure that it is set to use the long preamble
SSID Broadcast	When wireless clients survey the local area for wireless networks to associate with, they will detect the SSID broadcast by the AP. To broadcast the AP SSID, keep the default setting, Enable. If you do not want to broadcast the AP SSID, then select Disable.

X-Roaming

Extra parameters:

X-Roaming:

Disabled Standard

Roaming Signal Threshold:

dbm(range: 60~90, default 75)

Max Client Threshold:

(range: 1~32, default 10)

X-Roaming	<p>Disable: Disable X-Roaming protocol.</p> <p>Standard: Roaming group does not require the same wireless channel, but slower to switch than the “fixed channel” mode</p> <p>Fixed channel: Roaming group must be required the same wireless channel, but faster to switch than the “Standard” mode</p>
Signal Threshold for Roaming	<p>Roaming signal threshold setting. When signal below this value AP will roaming to another client target which the same SSID, security option and signal strongest within the environment.(This value just effect on client-mode equipment)</p>
Max Client Threshold	<p>Max number of client equipment setting. When client number over this value AP will reject roaming equipment connection.(This value just effect on AP-mode equipment)</p>

MAC Filter

Use **Advanced Setting > MAC Filters** to allow or deny wireless clients, by their MAC addresses, from accessing the IAP-W510 / W512. You can manually add a MAC address or select the MAC address from **Connected Clients** that are currently connected to the AP.

Advanced Setting --> MAC Filters

Filters are used to allow or deny Wireless Clients from accessing the AP.

MAC Filters: Enabled Disabled

Options

Only allow MAC address(es) listed below to connect to AP

Only deny MAC address(es) listed below to connect to AP

Associated Clients: Copy To

MAC Filter Table:

1.	<input type="text"/>	11.	<input type="text"/>	21.	<input type="text"/>
2.	<input type="text"/>	12.	<input type="text"/>	22.	<input type="text"/>
3.	<input type="text"/>	13.	<input type="text"/>	23.	<input type="text"/>
4.	<input type="text"/>	14.	<input type="text"/>	24.	<input type="text"/>
5.	<input type="text"/>	15.	<input type="text"/>	25.	<input type="text"/>
6.	<input type="text"/>	16.	<input type="text"/>	26.	<input type="text"/>
7.	<input type="text"/>	17.	<input type="text"/>	27.	<input type="text"/>
8.	<input type="text"/>	18.	<input type="text"/>	28.	<input type="text"/>
9.	<input type="text"/>	19.	<input type="text"/>	29.	<input type="text"/>
10.	<input type="text"/>	20.	<input type="text"/>	30.	<input type="text"/>

The following table describes the labels in this screen.

Label	Description
MAC Filter	Enable or disable the function of MAC filter. MAC address allowed or denied option is selected by you.
MAC Filter List	This list will display the MAC addresses that are in the selected filter.

Connected Clients	This list will display the wireless MAC addresses that linked with AP.
MAC Address	MAC addresses need to be added to or clear from MAC filter list.
Apply	Click Apply to set the configurations.

System Event

When the AP event triggered, the notification procedure will be performed according to the type of the event. Which notification would be performed depends on the selection of corresponding option in the **Advanced Setting > System Event** page.

Advanced Setting --> System Event

System Event Configuration.

Device Event Notification			
Hardware Reset (Cold Start)	<input type="checkbox"/> SMTP Mail	<input type="checkbox"/> SNMP Trap	<input type="checkbox"/> Syslog
Software Reset (Warm Start)	<input type="checkbox"/> SMTP Mail	<input type="checkbox"/> SNMP Trap	<input type="checkbox"/> Syslog
Login Failed	<input type="checkbox"/> SMTP Mail	<input type="checkbox"/> SNMP Trap	<input type="checkbox"/> Syslog
IP Address Changed	<input type="checkbox"/> SMTP Mail	<input type="checkbox"/> SNMP Trap	<input type="checkbox"/> Syslog
Password Changed	<input type="checkbox"/> SMTP Mail	<input type="checkbox"/> SNMP Trap	<input type="checkbox"/> Syslog
Redundant Power Changed	<input type="checkbox"/> SMTP Mail	<input type="checkbox"/> SNMP Trap	<input type="checkbox"/> Syslog
Eth Link Status Changed	<input type="checkbox"/> SMTP Mail	<input type="checkbox"/> SNMP Trap	<input type="checkbox"/> Syslog
SNMP Access Failed	<input type="checkbox"/> SMTP Mail	<input type="checkbox"/> SNMP Trap	<input type="checkbox"/> Syslog
Wireless Client Associated	<input type="checkbox"/> SMTP Mail	<input type="checkbox"/> SNMP Trap	<input type="checkbox"/> Syslog
Wireless Client Disassociated	<input type="checkbox"/> SMTP Mail	<input type="checkbox"/> SNMP Trap	<input type="checkbox"/> Syslog
Client Mode Associated	<input type="checkbox"/> SMTP Mail	<input type="checkbox"/> SNMP Trap	<input type="checkbox"/> Syslog
Client Mode Disassociated	<input type="checkbox"/> SMTP Mail	<input type="checkbox"/> SNMP Trap	<input type="checkbox"/> Syslog

Fault Event Notification			
Eth1 Link Down	<input type="checkbox"/> SMTP Mail	<input type="checkbox"/> SNMP Trap	<input type="checkbox"/> Syslog

System events record the activities of the AP system. When the setting changes or action performs, the event will be sent to administrator by email. A trap will also be sent to SNMP server. The Syslog will record the event locally and may send the log remotely to a Syslog server.

Email Settings

E-mail settings

SMTP Server: (optional)

Server Port: (0 represents default)

E-mail Address 1:

E-mail Address 2:

E-mail Address 3:

E-mail Address 4:

The following table describes the labels in this screen.

Label	Description
SMTP Server	Simple Message Transfer Protocol, enter the backup host to use if primary host is unavailable while sending mail by SMTP server.
Server Port	Specify the port where MTA can be contacted via SMTP server.
E-mail Address 1-4	Inputs specify the destination mail address.

SNMP Settings

SNMP settings

SNMP Agent: Enable Disable

SNMP Trap Server 1:

SNMP Trap Server 2:

SNMP Trap Server 3:

SNMP Trap Server 4:

Community:

SysLocation:

SysContact:

The following table describes the labels in this screen.

Label	Description
SNMP Agent	SNMP (Simple Network Management Protocol) Agent is a service program that runs on the access point. The agent provides management information to the NMS by keeping track of various operational aspects of the AP system. Turn on to open this service and off to shutdown it.
SNMP Trap Server 1-4	Specify the IP of trap server, which is the address to which it will send traps AP generates.
Community	Community is essentially password to establish trust between managers and agents. Normally "public" is used for read-write community.
SysLocation	Specify sysLocation string.
SysContact	Specify sysContact string.

Syslog Server Settings

Syslog Server settings

Syslog Server IP:

Syslog Server Port: (0 represents default)

The following table describes the labels in this screen.

Label	Description
Syslog Server IP	Not only the syslog keeps the logs locally, it can also log to remote server. Specify the IP of remote server. Leave it blank to disable logging remotely.
Syslog Server Port	Specify the port of remote logging. Default port is 514.

5.5.3 System Tools

Administrator

In this page, you can change the username and password. The new password must be typed twice to confirm (the default Name and Password is "admin" and "").

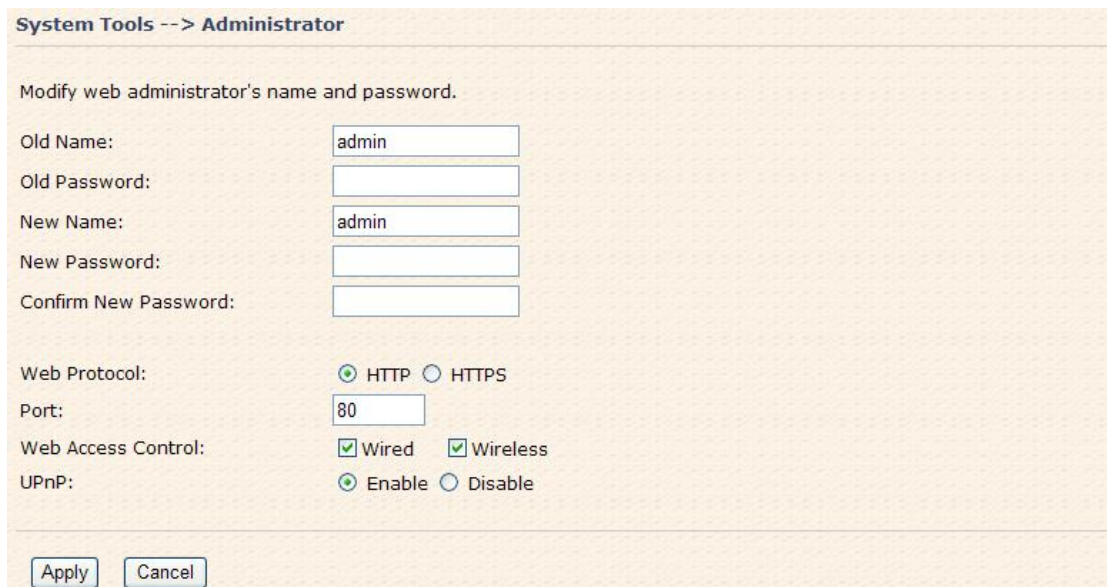

The following table describes the labels in this screen.

Label	Description
Old Name	This field displays the old login name. It's read only. The default value of login name is "admin".
Old Password	Before making a new setting, you should provide the old password for a verify check. Acceptable inputs of this field contains '0-9', 'a-z', 'A-Z' and must be between 0 to 15 characters in length. The factory default value of login password is null.
New Name	Enter a new login name. Acceptable inputs of this field contains '0-9', 'a-z', 'A-Z' and must be between 1 to 15 characters in length.

	This field can't accept null input.
New Password	Enter a new login password. Acceptable inputs of this field contains '0-9', 'a-z', 'A-Z' and must be between 0 to 15 characters in length.
Confirm New Password	Retype the password to confirm it. Acceptable inputs of this field contains '0-9', 'a-z', 'A-Z' and must be between 0 to 15 characters in length.
Web Protocol	Choose on the protocol for web. The default value is HTTP , if you want the web pages' security is better, choose the HTTPS protocol.
Port	Corresponding to the Web protocol, there is a default port (HTTP: 80, HTTPS: 443). And you can enter another number which should be in range of 1-65535.
Web Access Control	Choose the checkbox of the Wired and Wireless; you can visit the web page through the mode you choose.
UPnP	Pitch on "Enable", and the UPnP will display in the right-behind corner.

HTTPS (HTTP over SSL) is a Web protocol developed by Netscape and built into its browser that encrypts and decrypts user page requests as well as the pages that are returned by the Web server.

Date & Time

In this page, set the date & time of the device. The correct date & time will be helpful for logging of system events. A NTP (Network Time Protocol) client can be used to synchronize date & time with NTP server.

System Tools --> Date/Time

Date/Time settings.

Local Date: 2008 Year 5 Month 13 Day

Local Time: 11 Hour 40 Minute 58 Second

Time Zone: GMT+08:00

Get Current Date & Time from Browser

NTP: Enable

NTP Server 1: time.nist.gov

NTP Server 2: pool.ntp.org (optional)

Synchronise: Every Hour at 00 : 00

Apply Cancel

The following table describes the labels in this screen.

Label	Description
Local Date	Set local date manually.
Local Time	Set local time manually.
Time Zone	Select the time zone manually
Get Current Date & Time from Browser	Click this button, you can set the time from browser.
NTP	Enable or disable NTP function to get the time from the NTP server.
NTP Server 1	The initial choice about NTP Server.
NTP Server 2	The second choice about NTP Server.
Synchronize	Set the time, and the AP's time synchronize with the NTP Server at the time

Configuration

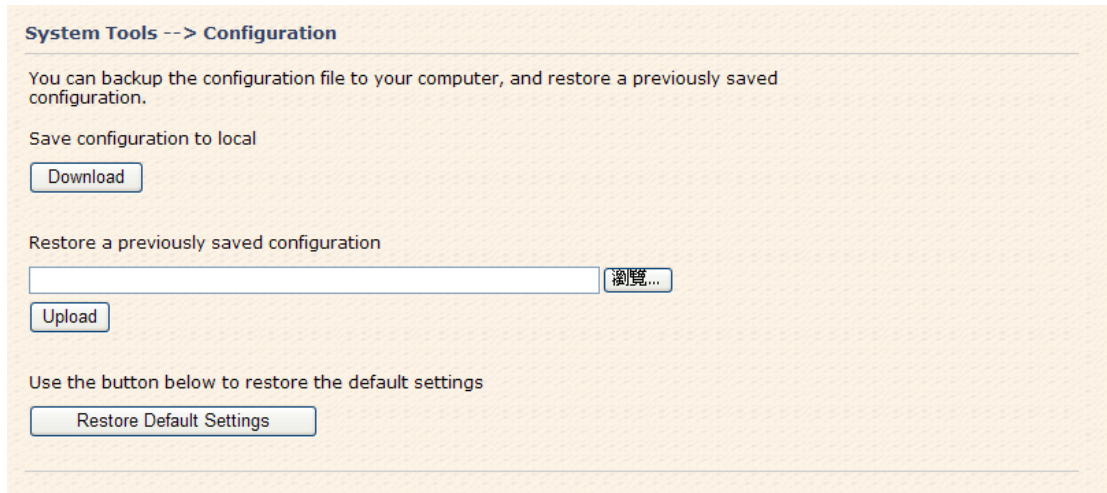

The following table describes the labels in this screen.

Label	Description
Download configuration	The current system settings can be saved as a file onto the local hard drive.
Upload configuration	The saved file or any other saved setting file can be uploaded back on the AP. To reload a system settings file, click on Browse to browse the local hard drive and locate the system file to be used. Click Upload when you have selected the file to be loaded back onto the AP.
Restore Default Settings	You may also reset the IAP-510 / 512 back to factory settings by clicking on Restore Default Settings . Make sure to save the unit's settings before clicking on this button. You will lose your current settings when you click this button.

Firmware Upgrade

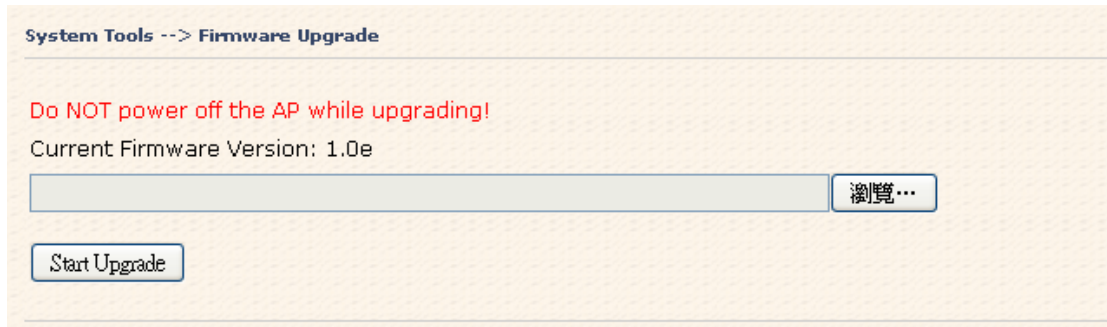

System Tools --> Firmware Upgrade

Do NOT power off the AP while upgrading!

Current Firmware Version: 1.0e

瀏覽...

Start Upgrade

New firmware may provide better performance, bug fixes or more functions. To upgrade, you need a firmware file correspond to this AP model. It will take several minutes to upload and upgrade the firmware. After the upgrade is done successfully, the access point will reboot and get revalidated.

Notice: DO NOT POWER OFF THE AP OR PRESS THE RESET BUTTON WHILE THE FIRMWARE IS BEING UPGRADED.

Miscellaneous

If you want to restart the access point through the **Warm Reset**, click **Restart Now** to restart the AP.

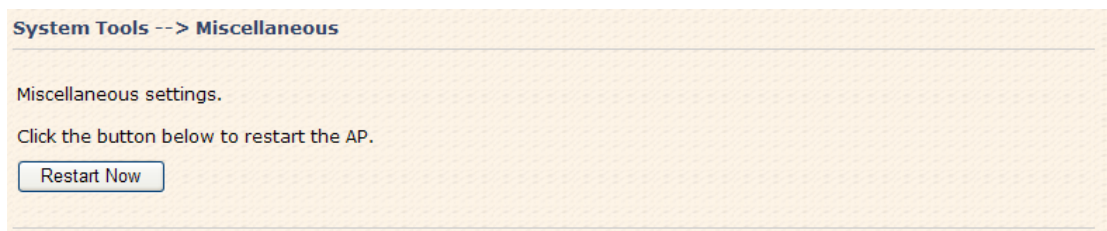

System Tools --> Miscellaneous

Miscellaneous settings.

Click the button below to restart the AP.

Restart Now

5.5.4 System Status

System Info

System Status --> System Info

System information details.

Model

Model Name:	IAP-W512_US
Model Description:	Industrial 802.11a/n Access Point US band

Firmware

Version:	1.0e
----------	------

Ethernet

MAC Address:	00:11:A3:04:04:05
IP Address:	192.168.10.2
Subnet Mask:	255.255.255.0
Default Gateway:	0.0.0.0
DHCP Server:	Disabled

Operation Mode

Operation Mode:	AP
-----------------	----

Wireless

MAC Address:	00:11:A3:04:04:00
SSID:	oring
Encryption:	No encryption
Signal Strength:	----
Channel:	(Auto)
WDS MAC Address:	00:11:A3:04:04:00

AP-Client Connection Info:

This page displays the current information for the IAP-W510 / W512. It will display model name, as well as firmware version, Ethernet, Wireless info and device time.

System Log

System Status --> System Log

System log details.

#	Date Time	Content
---	-----------	---------

The system log tracks the important events and setting changes of the AP. If the AP is rebooted, the logs are automatically cleared.

Click the button '**Refresh**' to refresh the page; Click the button '**Clear**' to clear log entries.

Traffic Statistics

System Status --> Traffic/Port Status

Traffic status displays received and transmitted packets passing through the AP.

Interface	Send	Receive
Ethernet	777405 Bytes (7325 Packages)	90898 Bytes (667 Packages)
Wireless	598445 Bytes (6825 Packages)	3652 Bytes (10 Packages)

Port status displays the state of all ports in AP.

Port	State
Ethernet Port1	Link down, forwarding
Wireless Port	forwarding
AP-Client Virtual Port	Not Set
WDS Virtual Port1	Not Set
WDS Virtual Port2	Not Set
WDS Virtual Port3	Not Set
WDS Virtual Port4	Not Set

This page displays the network traffic statistics for both received and transmitted packets through the Ethernet port and wireless connections associated with the AP. Simultaneity, the traffic counter will reset by the device rebooting.

Wireless Clients

System Status --> Wireless Clients

List of connected wireless clients.

Mac Address	Send	Receive	Current TxRate
00:20:b3:10:24:8d	2825 Bytes	4097 Bytes	54 Mbps

This page of the list displays the **Mac Address** of the wireless clients connected.

Current TX Rate is corresponding to the **Transmission Rate** in the **Advanced Setting**

> **Wireless** pages.

5.5.5 Online Help

Click on any item in the **Online Help** screen for more information.

Index	Home -> Setup Wizard
Home <ul style="list-style-type: none">■ Setup Wizard	Setup Wizard <p>The Setup Wizard is a useful and easy utility to help setup the AP to quickly adapt it to your existing network with only a few steps required. It will guide you step by step to configure the settings of the AP. The Setup Wizard is a helpful guide for first time users to the AP.</p> <p>For step 1, you can set a new login password if required, the default login name is 'admin', and default login password is null.</p> <p>For step 2, you can set the wireless SSID name and channel, a default SSID has been provided for you. By default the channel is set to 6.</p> <p>For step 3, set the wireless encryption to WEP will strengthen the security of the wireless network, or just leave encryption disabled and anyone can connect to the AP.</p> <p>For step 4, save the previous settings and revalidate the AP.</p>
Basic Setting <ul style="list-style-type: none">■ Operation Mode■ WDS■ Wireless■ LAN Setting■ DHCP Server	
Advanced Setting <ul style="list-style-type: none">■ Wireless■ MAC Filter■ Email/SNMP/Syslog■ System Event	
System Tools <ul style="list-style-type: none">■ Administrator■ Date & Time■ Configuration■ Firmware Upgrade■ Miscellaneous	
System Status <ul style="list-style-type: none">■ System Info■ System Log■ Traffic Stats■ Wireless Clients	

Technical Specifications

LAN Interface	
RJ45 Ports	1 x 10/100Base-T(X), Auto MDI/MDI-X
Protocols	IP, TCP, UDP, DHCP, BOOTP, ARP/RARP, DNS, SNMP MIB II, HTTPS, SNMPV1/V2, Trap, Private MIB
WLAN Interface	
Operating Mode	AP/Bridge/Repeater/AP-Client/Client
Antenna Connector	2 x External N-type antenna connector for IAP-W512, Build-in 15dBi panel antenna for IAP-W510
Radio Frequency Type	OFDM
Modulation	IEEE802.11a : OFDM with BPSK, QPSK, QAM, 64QAM IEEE802.11n : BPSK, QPSK, 16-QAM, 64-QAM
Frequency Band	America / FCC : 5.15 to 5.825 GHz (13 channels) Europe CE / ETSI : 5.15 to 5.724 GHz (19 channels)
Transmission Rate	IEEE802.11a: 6/ 9/ 12/ 18/ 24/ 36/ 48/ 54 Mbps IEEE801.11n: 300Mbps
Transmit Power	IEEE802.11a/n: 500mw
Receiver Sensitivity	-82dBm @ 54Mbps, PER< 10%; -78dBm@MCS 15(11n, 20MHz), PER< 10%; -75dBm@MCS 15(11n, 40MHz), PER< 10%
Encryption Security	WEP: (64-bit ,128-bit key supported) WPA/WPA2 :802.11i(WEP and AES encryption) WPAPSK (256-bit key pre-shared key supported)
Wireless Security	SSID broadcast disable
LED Indicators	1. PWR: 1 x LED Green On: Power is on and functioning Normally.



	2. LAN: 1 x LED Green On: Port Link Green Blinking: Transmitting data 3. WLAN: 1 x LED Green for WLAN Link/ Act
Power Requirements	
Power Input Voltage	12~68VDC
Power Consumption	9 Watts
Environmental	
Operating Temperature	-30 to 70°C
Storage Temperature	-30 to 85°C
Operating Humidity	100% non-condensing
Mechanical	
Dimensions(W x D x H)	162 mm(W)x 102 mm(D)x 58 mm(H) for IAP-W510 162 mm(W)x 102 mm(D)x 48 mm(H) for IAP-W512
Casing	IP-67 protection
Regulatory Approvals	
Regulatory Approvals	FCC Part 15, CISPR (EN55022) class A
EMS	EN61000-4-2 (ESD), EN61000-4-3 (RS), EN61000-4-4 (EFT), EN61000-4-5 (Surge), EN61000-4-6 (CS), EN61000-4-8, EN61000-4-11
Shock	IEC 60068-2-27
Free Fall	IEC 60068-2-32
Vibration	IEC 60068-2-6
Safety	EN60950-1
Warranty	3 years

APPENDIX A

How to configure SNMP MIB and use SNMP in the PCs?

Step 1, Set Enable about the SNMP in the web of Advanced Setting→Email/SNMP/Syslog, and input the IP address of the PC used for SNMP trap server.

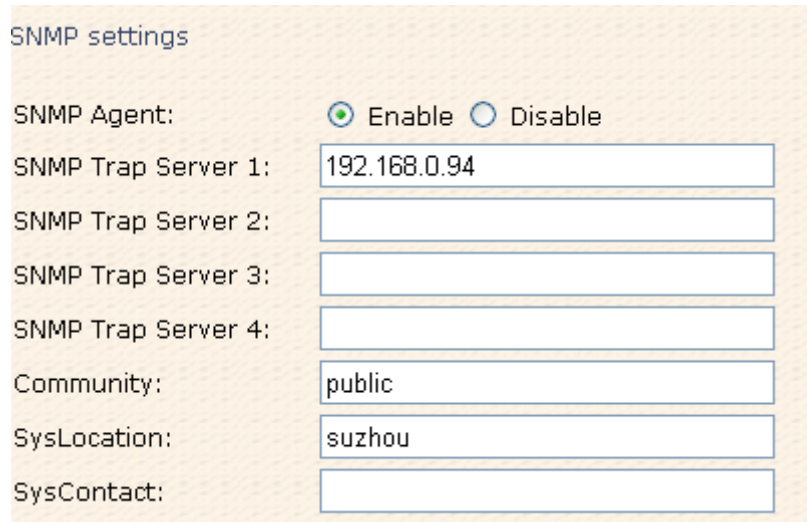

SNMP settings

SNMP Agent:	<input checked="" type="radio"/> Enable <input type="radio"/> Disable
SNMP Trap Server 1:	<input type="text" value="192.168.0.94"/>
SNMP Trap Server 2:	<input type="text"/>
SNMP Trap Server 3:	<input type="text"/>
SNMP Trap Server 4:	<input type="text"/>
Community:	<input type="text" value="public"/>
SysLocation:	<input type="text" value="suzhou"/>
SysContact:	<input type="text"/>

Step 2, In the PC, you should setup the SNMP trap server. This here, we use MG-SOFT for example.

1. The location of the License should configure right during the process of the installation.

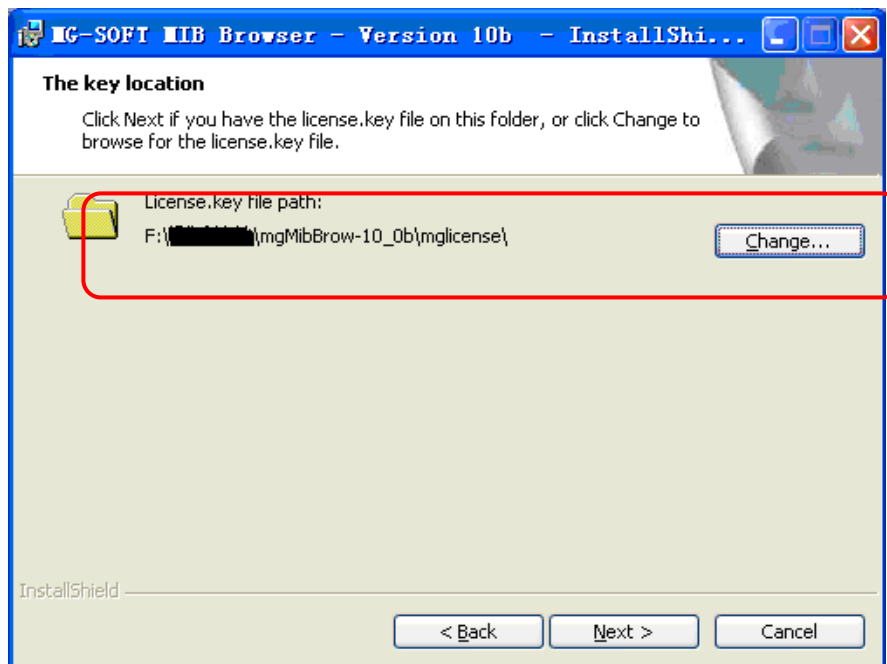

- After the installation, click into MIB Compile to add the MIB files(for example, the Oring 802.11a/b/g and no PoE FW), and save the configuration.

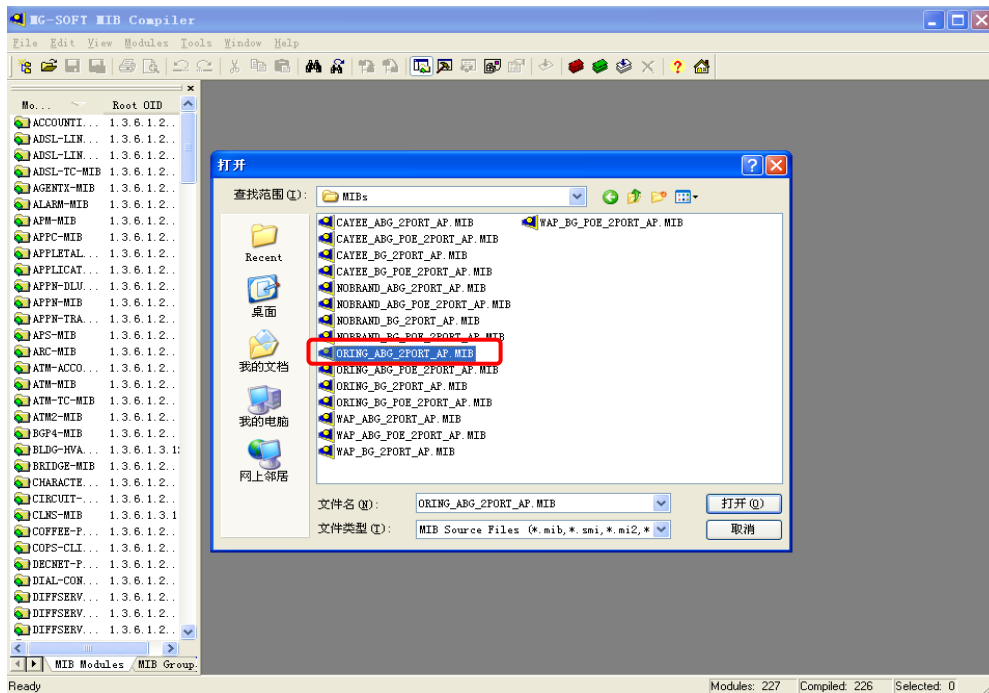

- Open MIB Browser and select the list of MIB, then select the ORING-ABG-2Port-AP-MIB which in the MIB Modules to add in the Loaded MIB modules.

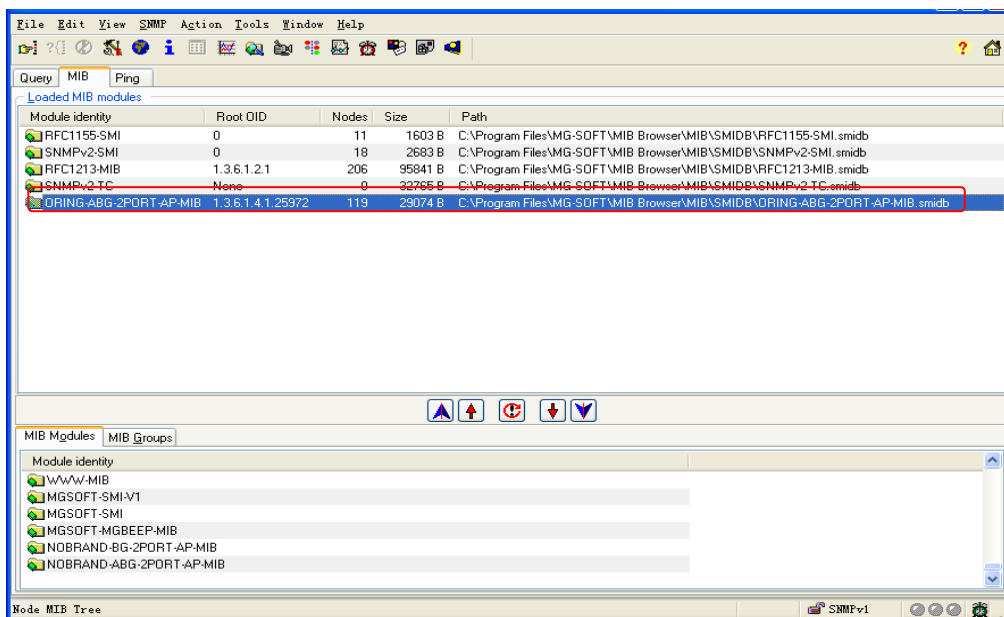

- Click into Query list in the MIB Browser, and input the IP address of the AP in the Remote SNMP agent→ click “Apply”, there is an alarm box which let you enter the right

community.

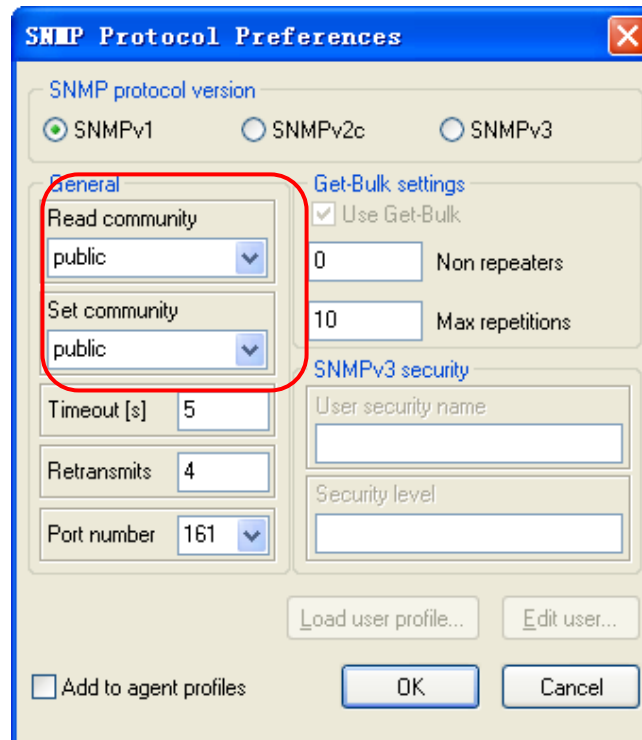

The image shows a dialog box titled "SNMP Protocol Preferences". At the top, it has three radio buttons for "SNMPv1", "SNMPv2c", and "SNMPv3", with "SNMPv1" selected. Below this are three main sections: "General", "Get-Bulk settings", and "SNMPv3 security". The "General" section contains a "Read community" dropdown menu with "public" selected, a "Set community" dropdown menu with "public" selected, a "Timeout [s]" text box with "5", a "Retransmits" text box with "4", and a "Port number" dropdown menu with "161". The "Get-Bulk settings" section has a checked "Use Get-Bulk" checkbox, a "Non repeaters" text box with "0", and a "Max repetitions" text box with "10". The "SNMPv3 security" section has a "User security name" text box and a "Security level" text box. At the bottom, there are "Load user profile..." and "Edit user..." buttons, an "Add to agent profiles" checkbox, and "OK" and "Cancel" buttons. A red rectangle highlights the "Read community" and "Set community" dropdown menus.

5. After all the settings, you can see the information about the Oring AP in the MIB Tree.

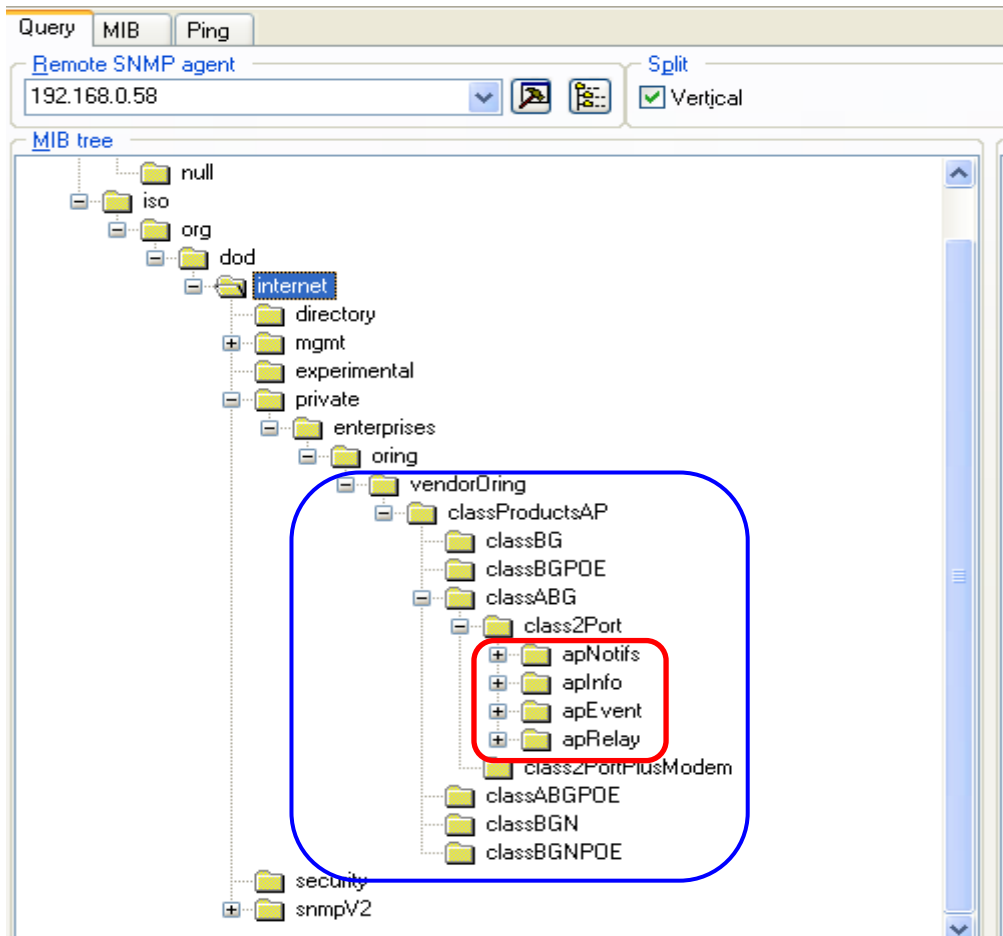

Step 3, Be familiar with SNMP information

1. The **apNotifs** list will show the trap box. To modify password as an example → select the SNMP Trap option in the **Advanced Setting** → **System Event** page → modify the password in the page of Administrator → it will be have trap box in the SNMP.

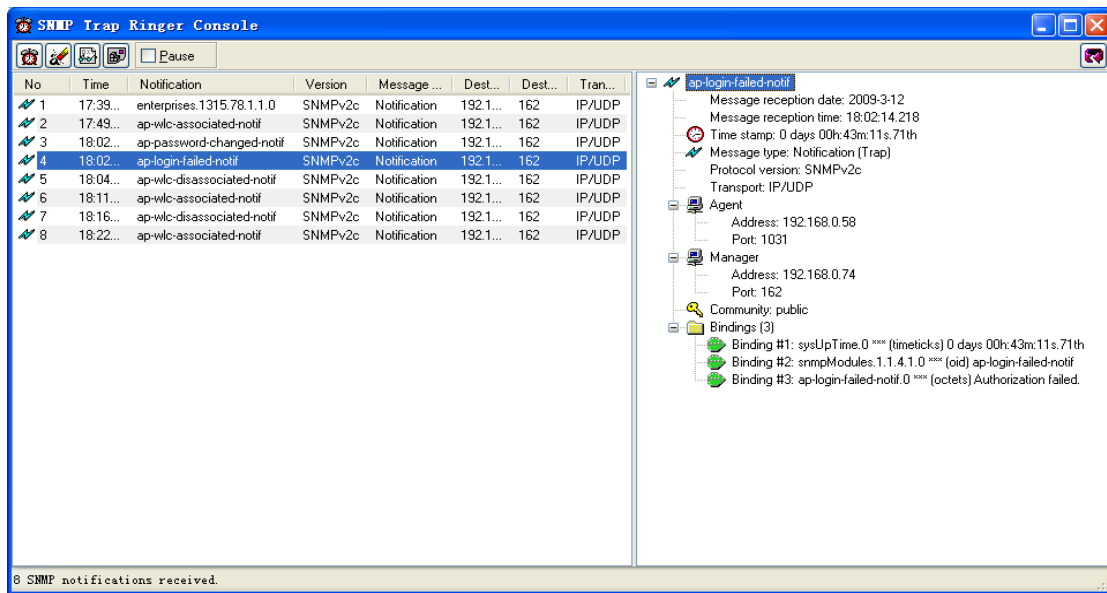

- The apInfo shows the basic information of the AP. To apSignalStrengthInfo as an example, right-click select "Get" on access to the Signal Strength information.

Shows in SNMP :	Shows in the web page
Response binding: 1: apSignalStrengthInfo.0 (octet string) 100 [31.30.30 (hex)]	Signal Strength: 100%

- The apEvent shows the same content with the page of the System Event and you can also configure the options. To PAddrChangedMail in the ipAddrChanged for example → now. status is in selected and the SNMP value is 1 → Set the SNMP value to 0, then the web page will be not selected.

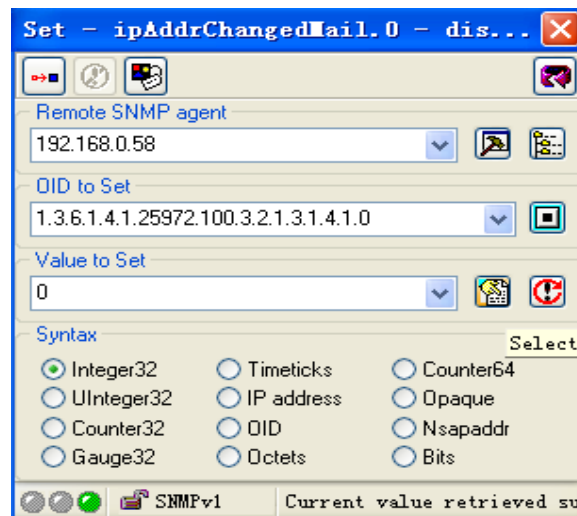

4. Also have the relevant information, you can right-click "Properties" to view a specific property features.