

# Industrial Device Server User's Manual

---

## IDS-5042-WG / 5042-IWG Series



Version 1.0

May 2008.



**ORing Industrial Networking Corp.**

4F., NO.3, Lane235, Baociao Rd.Sindian City,

Taipei County 23145 Taiwan, R.O.C.

Tel: + 886 2 2918 3036

Fax:+ 886 2 2918 3084

Website : [www.oring-networking.com](http://www.oring-networking.com)

E-mail : [support@oring-networking.com](mailto:support@oring-networking.com)

# Table of Content

<b>GETTING TO KNOW YOUR DEVICE SERVER .....</b>	<b>1</b>
1.1    About the IDS-5042-WG / 5042-IWG Serial Device Server .....	1
1.2    Software Features .....	1
1.3    Hardware Features .....	2
<b>HARDWARE INSTALLATION .....</b>	<b>3</b>
2.1    Install IDS-5042-WG / 5042-IWG on DIN-Rail .....	3
2.1.1    Mount IDS-5042-WG / 5042-IWG on DIN-Rail .....	3
2.2    Wall Mounting Installation .....	4
2.2.1    Mount IDS-5042-WG / 5042-IWG on wall .....	5
<b>HARDWARE OVERVIEW .....</b>	<b>8</b>
3.1    Front Panel .....	8
3.2    Front Panel LEDS .....	9
3.3    Serial Ports .....	10
3.4    Bottom Panel .....	11
3.5    Rear Panel .....	12
<b>CABLES .....</b>	<b>13</b>
4.1    Ethernet Cables .....	13
<b>MANAGEMENT INTERFACE .....</b>	<b>15</b>
5.1    DS-Tool .....	15
5.1.1    Install IDS-Tool .....	15
5.1.2    Using DS-Tool .....	17
5.1.2.1    Explore device servers .....	17
5.1.2.2    Configure device servers .....	18
5.1.2.3    Configure serial port .....	26
5.2    Configuration by Web Browser .....	35
5.2.1    Connect to the Web page .....	35
5.2.1.1    System .....	37
5.2.1.2    Port serial setting .....	42



5.2.1.3	Management .....	50
5.2.1.4	Save/Reboot.....	54
5.3	Configuration by SSH Console .....	55
5.3.1	Connect to DS.....	55
<b>TECHNICAL SPECIFICATIONS .....</b>		<b>56</b>





# Getting to Know Your Device Server

## 1.1 About the IDS-5042-WG / 5042-IWG Serial Device Server



IDS-5042-WG / 5042-IWG is an innovative 4 ports RS232/422/485 to 802.11b/g WLAN and 2 ports LAN device server. Users are able to configure the Switch by DS-Tool via LAN port or WLAN interface, but not simultaneously. Once LAN port is activated, WLAN interface will enter standby mode to minimize power consumption. IDS-5042-WG / 5042-IWG offers many powerful features for HW & SW redundant functions. When the connection between master-link and LAN fails, IDS-5042-WG / 5042-IWG can automatically switch to another LAN port within 10mS, and still guarantees a non-stop connection.

IDS-5042-WG / 5042-IWG also supports switch mode, users can use Daisy Chain to reduce the usage of Ethernet switch ports. Secondly, IDS-5042-WG / 5042-IWG can simultaneously transfer data into 5 host PCs. This feature can assure all critical data that saved in different host PCs to avoid Ethernet break or host PCs failure.

Thirdly, IDS-5042-WG / 5042-IWG provides dual redundant power inputs on terminal block. IDS-5042-WG / 5042-IWG also provides NAT pass through function so that users are able to manage IDS-5042-WG / 5042-IWG inside or outside the NAT router. It is easy for different IP domain users to use IDS-5042-WG / 5042-IWG. Therefore, IDS-5042-WG / 5042-IWG is the best communication solution for wireless application of quad-port serial devices.

## 1.2 Software Features

- Redundant Dual Ethernet Ports: Recovery time < 10ms.



- Switch Mode Supported: Daisy Chain support to reduce usage of switch ports.
- High Speed Air Connectivity: WLAN interface support up to 54Mbps link speed
- NAT-pass through: User can manage IDS-5042-WG / 5042-IWG through NAT router.
- Highly Security Capability: WEP/WPA/WPA2/TKIP supported
- Redundant Power Inputs: 12~48VDC on terminal block.
- Redundant multiple host devices: 5 simultaneous in Virtual COM, TCP Server, TCP Client mode, UDP.
- Secured Management by HTTPS and SSH.
- Versatile Modes: Virtual Com, Serial Tunnel, TCP Server, TCP Client, UDP
- Event Warning by Syslog, Email, SNMP trap, Relay and Beeper
- Various Windows O.S. supported: Windows NT/2000/ XP/ 2003/VISTA 32bits

### 1.3 Hardware Features

- Redundant Power Inputs: 12~48 VDC on terminal block and power jack
- Operating Temperature: -10 to 55°C
- Storage Temperature: -20 to 85°C
- Operating Humidity: 5% to 95%, non-condensing
- Casing: IP-30
- 2 10/100Base-T(X) Ethernet port
- Dimensions(W x D x H) : 52 mm(W)x 106 mm( D )x 144 mm(H)

# Hardware Installation

## 2.1 Install IDS-5042-WG / 5042-IWG on DIN-Rail

Each IDS-5042-WG / 5042-IWG has a Din-Rail kit on rear panel. The Din-Rail kit helps IDS-5042-WG / 5042-IWG to fix on the Din-Rail. It is easy to install the IDS-5042-WG / 5042-IWG on the Din-Rail:

### 2.1.1 Mount IDS-5042-WG / 5042-IWG on DIN-Rail

Step 1: Slant the IDS-5042-WG / 5042-IWG and mount the metal spring to Din-Rail.



Figure 2-1

Step 2: Push the IDS-5042-WG / 5042-IWG toward the Din-Rail until you heard a “click” sound.

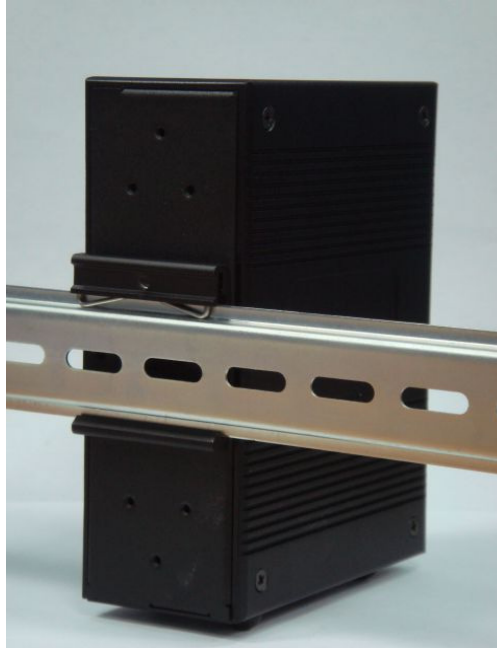

*Figure 2-2*

## 2.2 Wall Mounting Installation

Each IDS-5042-WG / 5042-IWG has another installation method for you. A wall mount panel can be found in the package. The following steps show how to mount the IDS-5042-WG / 5042-IWG on the wall:

## 2.2.1 Mount IDS-5042-WG / 5042-IWG on wall

Step 1: Remove Din-Rail kit.

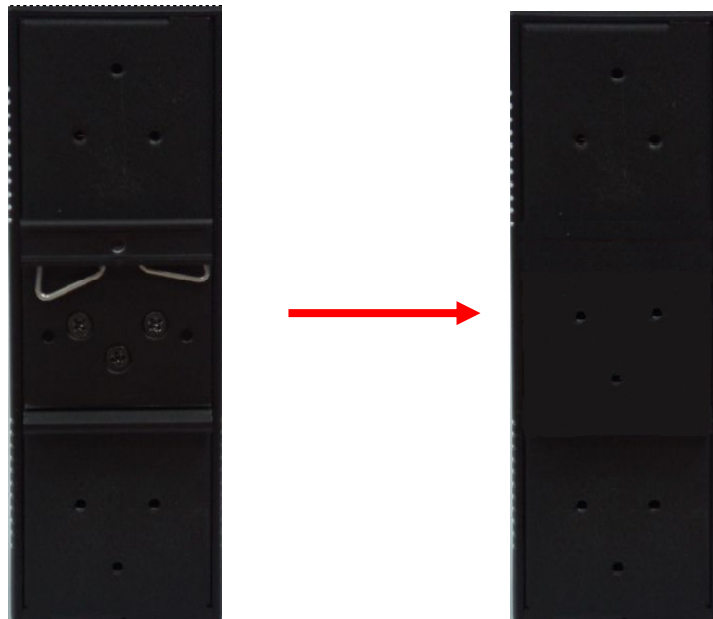

Figure 2-3

Step 2: Use 6 screws that can be found in the package to combine the wall mount panel.  
Just like the picture shows below:



Figure 2-4

The screws specification shows in the following two pictures. In order to prevent IDS-5042-WG / 5042-IWG from any damage, the size of screws should not be larger than the size that used in IDS-5042-WG / 5042-IWG.

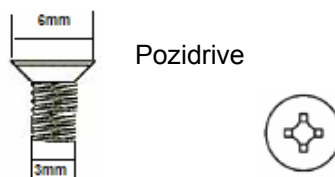

Figure 2-5

Step 3: Mount the combined IDS-5042-WG / 5042-IWG on the wall. .



Figure 2-6

# Hardware Overview

## 3.1 Front Panel

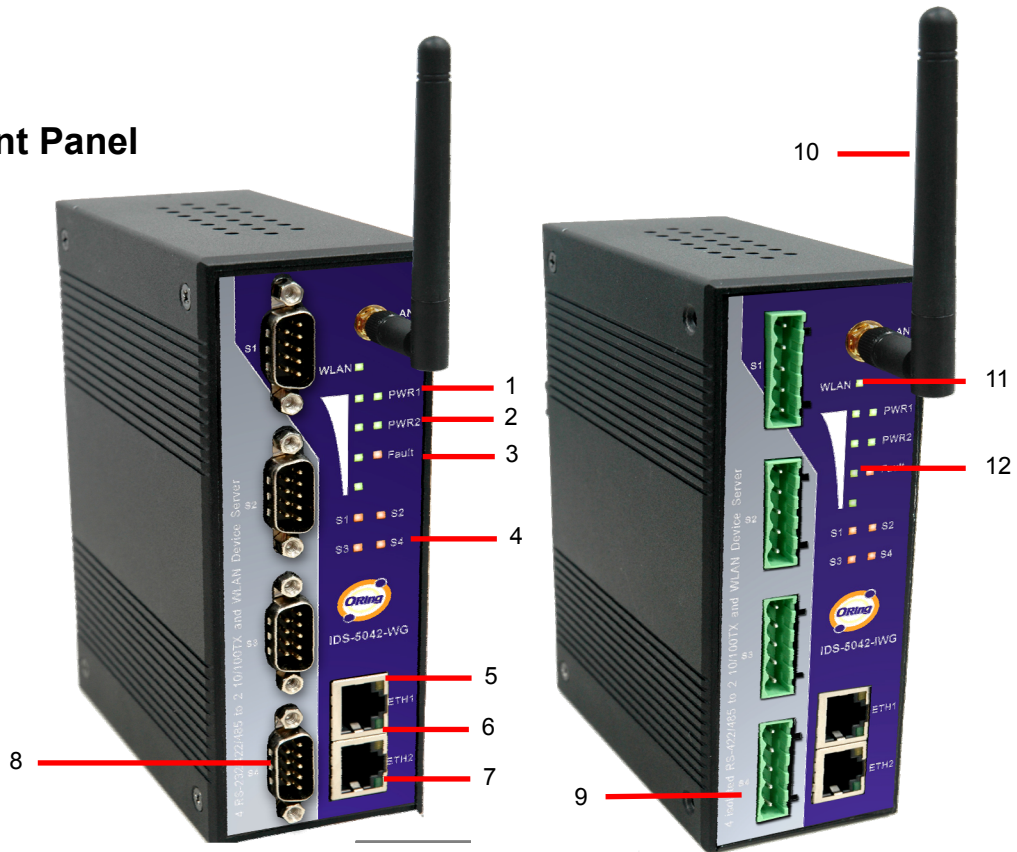

Figure 3-1

1. LED for PWR1 and system status. When the PWR1 links, the green LED will be light on.
2. LED for PWR2 and system status. When the PWR2 links, the green LED will be light on.
3. LED for fault indicator. When fault occurred, this red LED will be light on.
4. LED for Serial ports status. When data transmitted, the green LED will be light on. When data received, the red LED will be light on.
5. LED of 10Base-T connection on Ethernet port.





6. 10/100Base-T(X) Ethernet port
7. LED of 100Base-TX connection on Ethernet port.
8. RS-232/422/485 serial port. Mode configured by DS-Tool.
9. RS-422/485 serial port with 2KV isolation. Mode configured by DS-Tool.
10. Reverse SMA antenna connector.
11. LED for WLAN link status. When the WLAN links, the green LED will be light on.
12. LED for WLAN signal strength. 4 / 3 / 2 / 1 / 0 LED(s) will be light on correspond to WLAN signal strength 100% / 75% / 50% / 25% / BAD.

### 3.2 Front Panel LEDS

The following table describes the labels that stick on the IDS-5042-WG / 5042-IWG.

LED	Color	Status	Description
PWR1	Green/Red	On	DC power 1 activated.
		Red blinking	Indicates an IP conflict, or DHCP or BOOTP server did not respond properly
PWR2	Green/Red	On	DC power 2 activated.
		Red blinking	Indicates an IP conflict, or DHCP or BOOTP server did not respond properly
Fault	Red	On	Fault event occurred.
S1 ~ S4	Green	Blinking	Serial port is transmitting data
	Red	Blinking	Serial port is receiving data
ETH1	Green/Amber	Green On/Blinking	100Mbps LNK/ACT
		Amber On/Blinking	10Mbps LNK/ACT



ETH2	Green/Amber	Green On/Blinking	100Mbps LNK/ACT
		Amber On/Blinking	10Mbps LNK/ACT
WLAN	Green	On/Blinking	WLAN LNK/ACT
WLAN Signal	Green	On	4 / 3 / 2 / 1 / 0 LED(s) will be light on correspond to WLAN signal strength 100% / 75% / 50% / 25% / BAD

Table 3-1 Front panel LEDs

### 3.3 Serial Ports

There 4 serial ports on the front panel of IDS-5042-WG / 5042-IWG showed as below:

DB9 connector

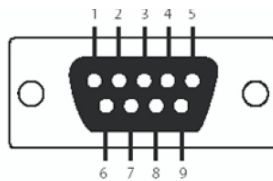

Pin #	RS 232	RS 422	RS 485 ( 4 wire )	RS 485 ( 2 wire )
1	DCD	RXD -	RXD -	
2	RXD	RXD +	RXD +	
3	TXD	TXD +	TXD +	DATA +
4	DTR	TXD -	TXD -	DATA -
5	GND	GND	GND	GND
6	DSR			
7	RTS			
8	CTS			
9	RI			
RS 232 mod act as DTE				

Table 3-2 Pin assignment

5 Pin Terminal block connector

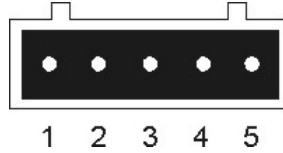

Pin #	RS 422	RS 485 ( 4 wire )	RS 485 ( 2 wire )
1	GND	GND	GND
2	RXD -	RXD -	
3	RXD +	RXD +	
4	TXD -	TXD -	DATA -
5	TXD +	TXD +	DATA +

### 3.4 Bottom Panel

The bottom panel components of IDS-5042-WG / 5042-IWG/42+/42-I+ are showed as below:

1. Terminal block includes: PWR1, PWR2 (12 ~ 48V DC) and Relay output (1A@24VDC).
2. Reset bottom. 5 seconds for factory default.

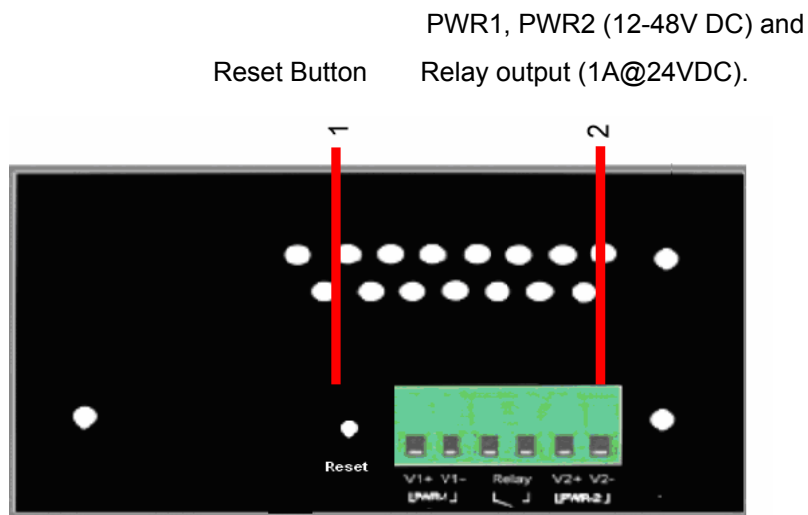

Figure 3-2 Bottom Panel

### 3.5 Rear Panel

The rear panel components of IDS-5042-WG / 5042-IWG are showed as below:

1. Screw holes for wall mount kit.
2. Din-Rail kit

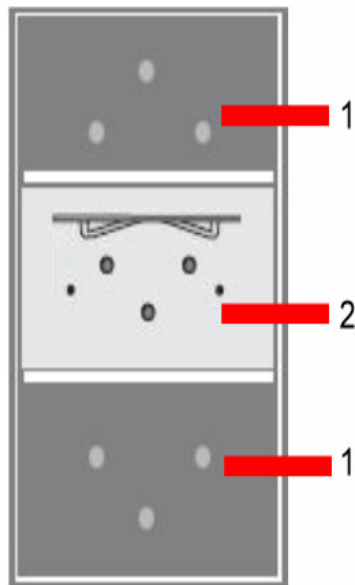

Figure 3-3 Rear Panel



# Cables

## 4.1 Ethernet Cables

The IDS-5042-WG / 5042-IWG has standard Ethernet ports. According to the link type, the IDS-5042-WG / 5042-IWG use CAT 3, 4, 5, 5e UTP cables to connect to any other network device (PCs, servers, switches, routers, or hubs). Please refer to the following table for cable specifications.

Cable	Type	Max. Length	Connector
10BASE-T	Cat. 3, 4, 5 100-ohm	UTP 100 m (328 ft)	RJ-45
100BASE-TX	Cat. 5 100-ohm UTP	UTP 100 m (328 ft)	RJ-45

*Table 4-1 Cable Types and Specifications*

### 100BASE-TX/10BASE-T Pin Assignments

With 100BASE-TX/10BASE-T cable, pins 1 and 2 are used for transmitting data, and pins 3 and 6 are used for receiving data.



Pin Number	Assignment
1	TD+
2	TD-
3	RD+
4	Not used
5	Not used
6	RD-
7	Not used
8	Not used

*Table 4-2 RJ-45 Pin Assignments*

The IDS-5042-WG / 5042-IWG supports auto MDI/MDI-X operation. You can use a straight-through cable to connect PC to IDS-5042-WG / 5042-IWG. The following table below shows the 10BASE-T/ 100BASE-TX MDI and MDI-X port pin outs.

Pin Number	MDI port	MDI-X port
1	TD+(transmit)	RD+(receive)
2	TD-(transmit)	RD-(receive)
3	RD+(receive)	TD+(transmit)
4	Not used	Not used
5	Not used	Not used
6	RD-(receive)	TD-(transmit)
7	Not used	Not used
8	Not used	Not used

*Table 4-2 MDI / MDI-X pins assignment*

**Note:** "+" and "-" signs represent the polarity of the wires that make up each wire pair.

# Management Interface

## 5.1 DS-Tool

DS-Tool is a powerful Windows utility for DS series. It supports device discovery, device configuration, group setup, group firmware update, monitoring functions...etc. It is easy for you to install and configure devices over the network.

### 5.1.1 Install IDS-Tool

Step 1: Execute the Setup program, click “**start**” after selecting the folder for DS-Tool.

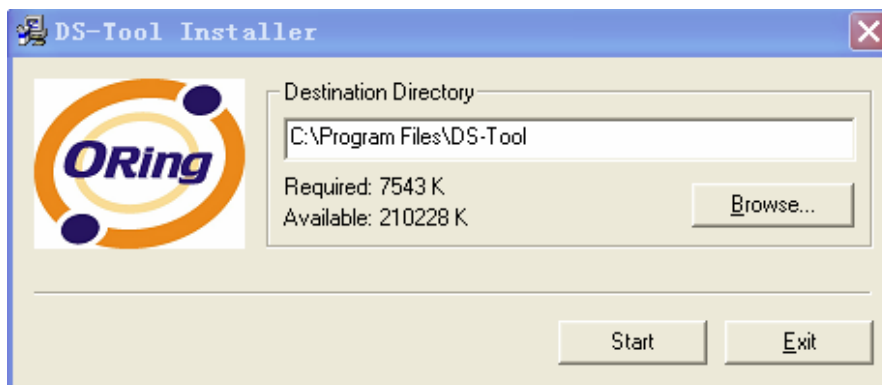

Figure 5-1



Step 2: When installation complete successfully, then click "OK".

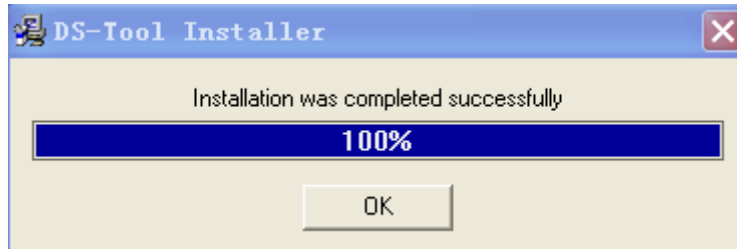

Figure 5-2

Step 3: Check for your selection.

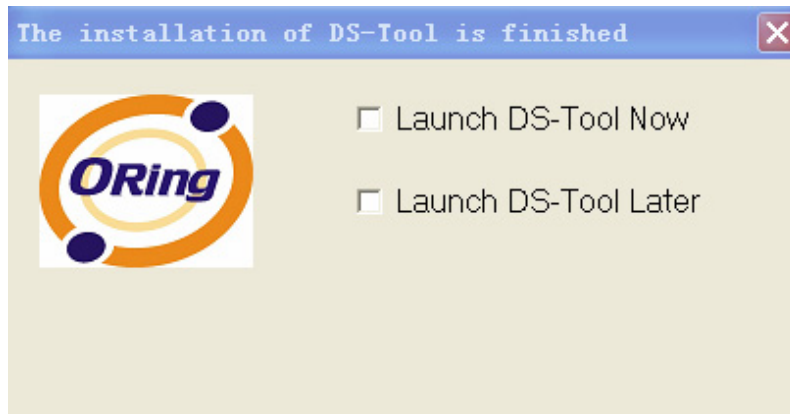

Figure 5-3



## 5.1.2 Using DS-Tool

### 5.1.2.1 Explore device servers

DS-Tool will broadcast to the network and search all available DS devices in the network. The default IP address of device is “**192.168.10.2**”, and selects the searching device you wish to use and press “**Add**” button.

You can set static IP address or in DHCP client mode to get IP address automatically. Finally, click “**OK**” button to add the device.

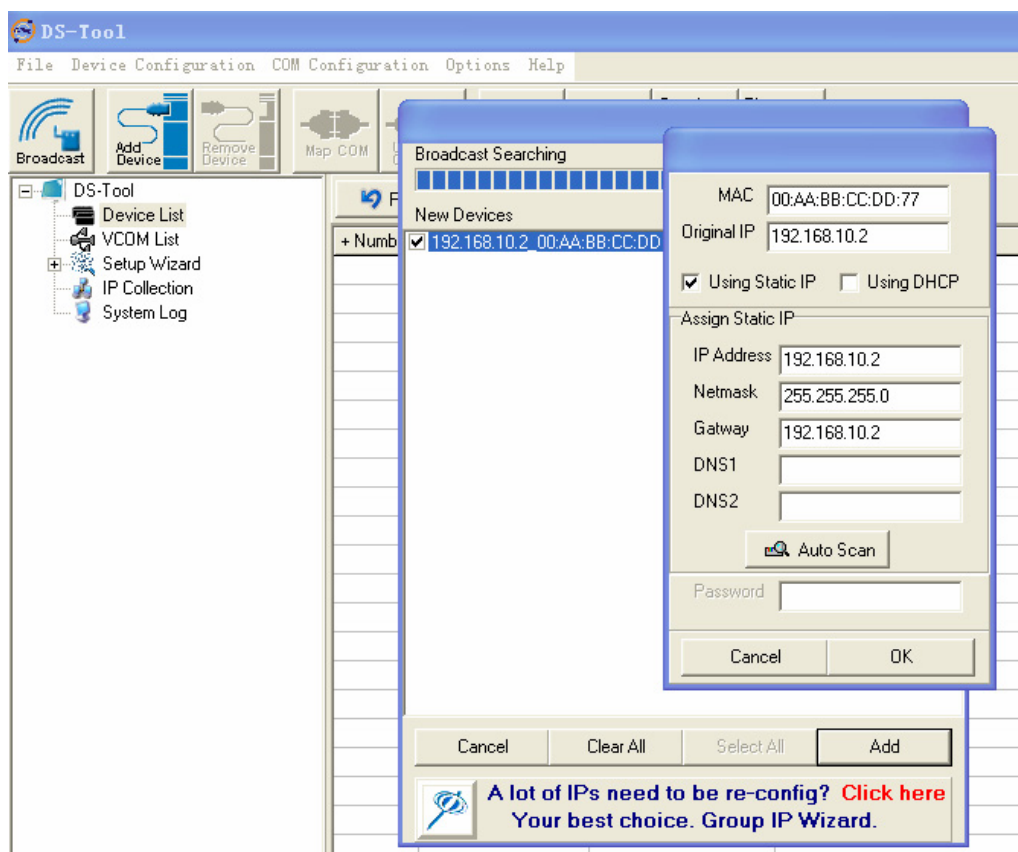

Figure 5-4



## 5.1.2.2 Configure device servers

### General settings

This page includes the setting of device name, SNTP server and Auto IP Report.

Figure 5-5 General settings

The following table describes the labels in this screen.

Label	Description
Device Name/location	You can set the device name or related information. By clicking “Locate On” button you can locate the serial server’s position.
Set SNTP	Input the SNTP server domain name or IP address, port and select the Time zone.

Set Auto IP Report	By Clicking the “ <b>Get current Host</b> ” button you will get your local IP, and then set the Report interval time. The device server will report its status periodically.
--------------------	--

*Table 5-1 General settings*

At IP collection option show the device server status. The report interval is 0 indicate disable this setting (default). But you can set the other IP or Port.

### Security

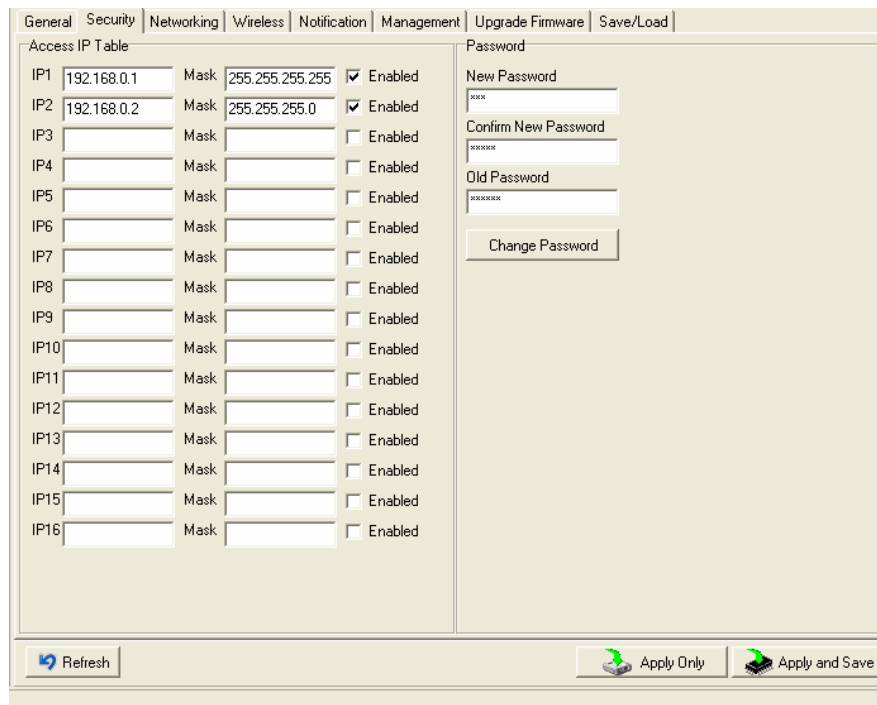

*Figure 5-6 Security*

The following table describes the labels in this screen.

Label	Description
Accessible IP Setting	To prevent unauthorized access by setting host IP addresses and network masks.
Password setting	You can set the password to prevent unauthorized access from your server. Factory default is no password.

*Table 5-2 Security*

## Network Setting

Device DS can connect the Network by wire and wireless. You must assign a valid IP address for DS before attached in your network environment. Your network administrator should provide you the IP address and related settings. The IP address must be unique within the network (otherwise, DS will not have a valid connection to the network). You can choose from three possible “**IP configuration**” modes: Static, DHCP/BOOTP. The Factory Default IP address is “**192.168.10.2**”

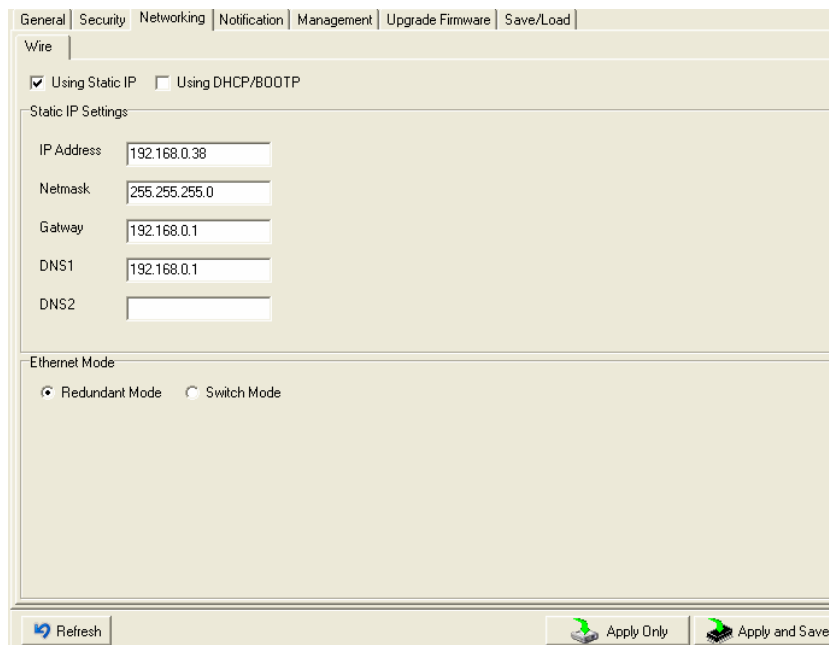

The screenshot shows a web-based configuration interface for network settings. At the top, there are tabs for General, Security, Networking, Notification, Management, Upgrade Firmware, and Save/Load. The 'Networking' tab is active, and the 'Wire' sub-tab is selected. Below the tabs, there are two radio buttons: 'Using Static IP' (checked) and 'Using DHCP/BOOTP' (unchecked). Under the 'Static IP Settings' section, there are five input fields: 'IP Address' (192.168.0.38), 'Netmask' (255.255.255.0), 'Gateway' (192.168.0.1), 'DNS1' (192.168.0.1), and 'DNS2' (empty). Below this, the 'Ethernet Mode' section has two radio buttons: 'Redundant Mode' (selected) and 'Switch Mode' (unselected). At the bottom of the interface, there are three buttons: 'Refresh', 'Apply Only', and 'Apply and Save'.

Figure 5-7 Network Setting



The following table describes the labels in this screen.

Label	Description
Using DHCP/BOOTP	IP Address automatically assigned by a DHCP server in your network.
Static IP Address	Manually assigning an IP address.
Subnet Mask	All devices on the network must have the same subnet mask to communicate on the network.
Gateway	Enter the IP address of the router in you network.
DNS Server	Enter the IP address of the DNS server, The DNS server translates domain names into IP address.
Switch Mode	<b>Redundant:</b> When the connection between master-link and LAN fails, the DS can automatically switch to another LAN port within10mS, and still guarantees a non-stop connection <b>Switch:</b> Daisy Chain support to reduce usage of switch ports.

Table 5-3 Network setting

## Wireless setting

Wireless Network type includes two modes: INFRA and ADHOC. The INFRA type connects the network by wireless access point, but the ADHOC is formed by the association of wireless and mobile devices capable of communicating among themselves even when there is no networking INFRA structure available.

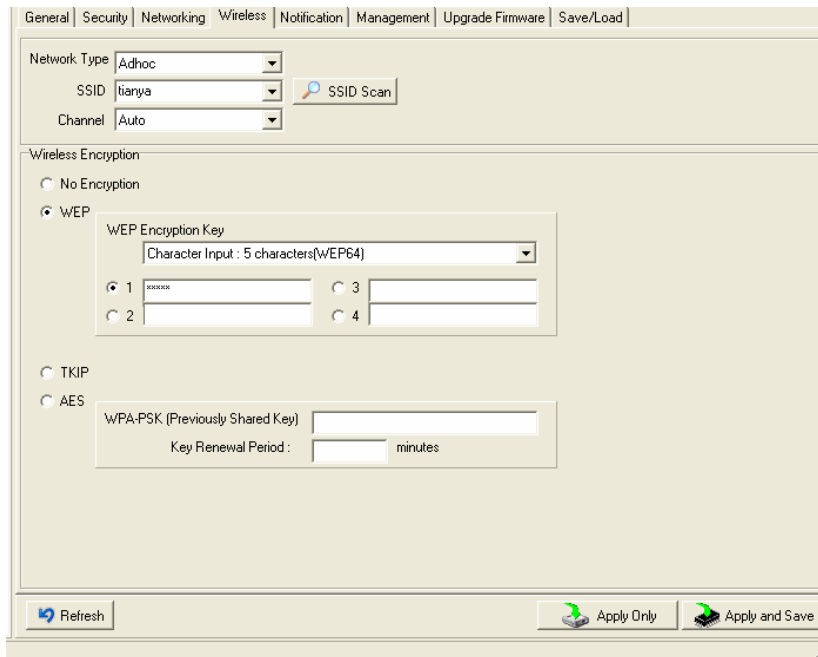

Figure 5-8 Wireless Network Setting

The following table describes the labels in this screen.

Label	Description
Network Type	Type includes INFRA and ADHOC.
SSID	Service Set Identifier Default is the default setting. The SSID is a unique name that identifies a network. All devices on a network must share the same SSID name in order to communicate on the network.
Channel	All devices on the network must be set to the same channel to communicate on the network. You can select the Auto.
NO Encryption	You can set no encryption mode, but this mode is insecurity and don't suggest use.
WEP	You can set four encryption 5characters (WEP64), 13 characters (WEP128), 10 digits (WEP64), 26digits (WEP128).
TKIP	TKIP (Temporal Key Integrity Protocol) is a key management protocol.
AES	AES (Advanced Encryption System) is a variable bit length symmetric digital encryption algorithm.

Table 5-3 Wireless Network setting

\*Simply unplug the RJ-45 to change into wireless connection

## Notification

Specify the events that should be notified to the administrator. The events can be alarmed by E-mail, SNMP trap, or system log.

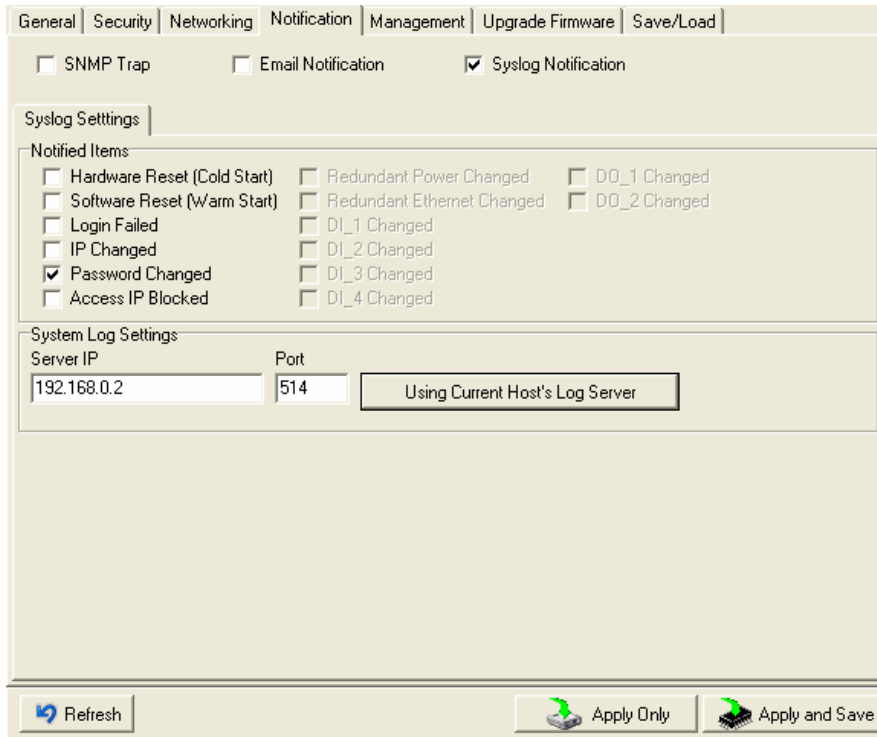

Figure 5-9 Notification

The following table describes the labels in this screen.

Label	Description
SNMP Trap	To notify events by SNMP trap.
Email Notification	To notify events by Email.
Syslog Notification	To notify events by Syslog.
Notify items	Events to be notified.
Apply	Apply current setting.
Apply and Save	Apply and save current setting.

Table 5-4 Notification

## Management

General | Security | Networking | Notification | **management** | Upgrade Firmware

Web Management Enable    Goto Web Management  
 Telnet Management Enable    Goto Telnet Management  
 SNMP Management Enable

SNMP Management Settings

Community

Location

Contact

Trap Server1

Trap Server2

Trap Server3

Trap Server4

*Figure 5-10 Management*

The following table describes the labels in this screen.

Label	Description
Web Management Enable	To enable management from Web. Click " <b>Goto Web Management</b> " button to access web.
Telnet Management Enable	To enable management by Telnet. Click " <b>Goto Telnet Management</b> " button to execute Telnet command.
SNMP Management Enable	To enable management by SNMP.
SNMP Management Settings	To configure SNMP related settings.

*Table 5-5 Management*



## Upgrade Firmware

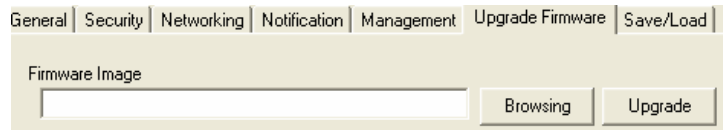

Figure 5-11 Upgrade Firmware

The following table describes the labels in this screen.

Label	Description
Browsing	Browse the file and upgrade
Upgrade	Enable the firmware upgrade.

Table 5-6 Upgrade Firmware

## Save/Load

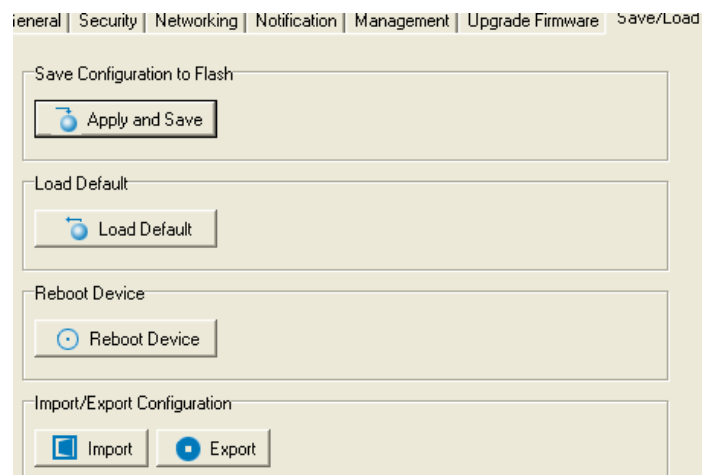

Figure 5-12 Save / Load

The following table describes the labels in this screen.

Label	Description
Save Configuration to Flash	Save current configuration into flash memory.



Load Default	Load default configuration except the network settings. If you want to load all factory default, you need to press “Reset” button on the device (Hardware restore).
Reboot Device	Reboot the device server (warm start).
Import Configuration	Restore the previous exported configuration.
Export Configuration	Exported current configuration to a file to backup the configuration.

Table 5-7 Save / Load

### 5.1.2.3 Configure serial port

#### Serial Settings

Figure 5-11 Serial Settings



The following table describes the labels in this screen.

Label	Description
Port Alias	Remark the port to hint the connected device.
Interface	RS232 / RS422 / RS485(2-wires) / RS485(4-wires)
Baud rate	110bps/300bps/1200bps/2400bps/4800bps/9600bps/19200bps/ 38400bps/57600bps/115200bps/230400bps/460800bps
Data Bits	5, 6, 7, 8
Stop Bits	1, 2 (1.5)
Parity	No, Even, Odd, Mark, Space
Flow Control	No, XON/XOFF, RTS/CTS, DTR/DSR
Performance	Throughput: This mode optimized for highest transmission speed. Latency: This mode optimized for shortest response time.
Serial to Ethernet	<p><b>Delimiter:</b> You can define max. 4 delimiters (00~FF, Hex) for each way. The data will be hold until the delimiters are received or the option-"<b>Flush Serial to Ethernet data buffer</b>" times out. 0 means disable. Factory default is 0.</p> <p><b>Flush Data Buffer After:</b> The received data will be queuing in the buffer until all the delimiters are matched. When the buffer is full (4K Bytes) or after "<b>flush S2E data buffer</b>" timeout the data will also be sent. You can set the time from 0 to 65535 seconds.</p>
Ethernet to Serial	<p><b>Delimiter:</b> You can define max. 4 delimiters (00~FF, Hex) for each way. The data will be hold until the delimiters are received or the option "<b>Flush Ethernet to Serial data buffer</b>" times out. 0 means disable. Factory default is 0.</p> <p><b>Flush Data Buffer After:</b> The received data will be queuing in the buffer until all the delimiters are matched. When the buffer is full (4K Bytes) or after "<b>flushE2S data buffer</b>" timeout the data will also be sent. You can set the time from 0 to 65535 seconds.</p>



Force TX Interval Time	Force TX interval time is to specify the timeout when no data has been transmitted. When the timeout is reached or TX buffer is full (4K Bytes), the queued data will be sent. 0 means disable. Factory default value is 0.
------------------------	---

Table 5-8 Serial settings

### Service Mode – Virtual COM Mode

In Virtual COM Mode, The driver establishes a transparent connection between host and serial device by mapping the Port of the serial server serial port to local COM port on the host computer. Virtual COM Mode also supports up to 5 simultaneous connections, so that multiple hosts can send or receive data by the same serial device at the same time.

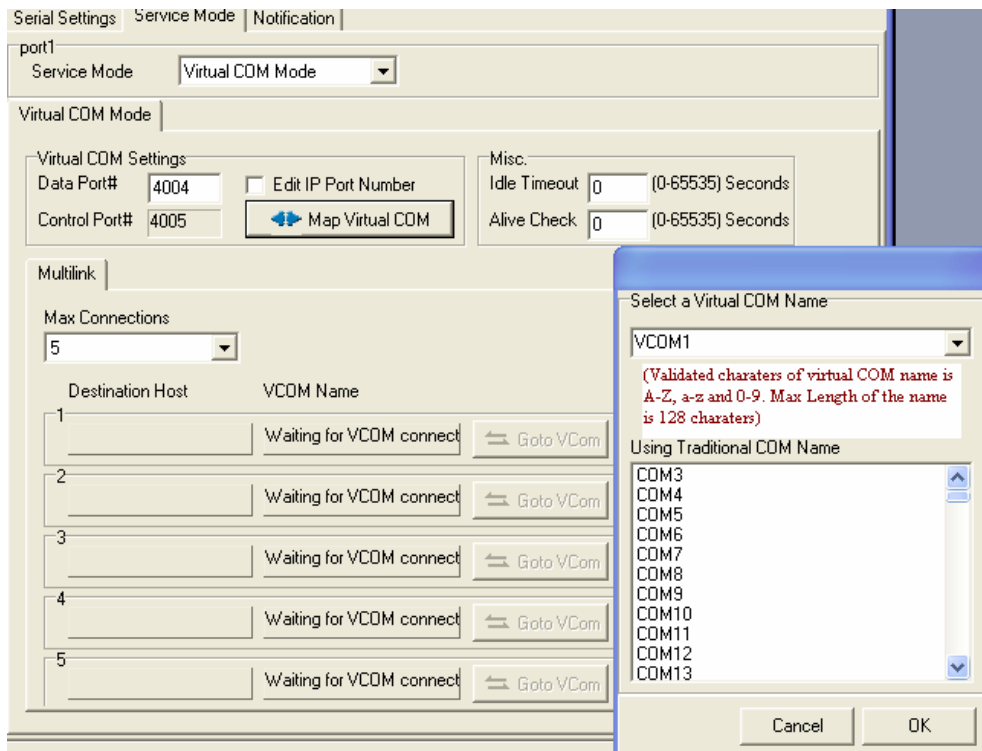

Figure 5-12 Virtual COM



The following table describes the labels in this screen.

Label	Description
Map Virtual COM	Select a Virtual COM Name to map on.
Max Connection	The number of Max connection can support simultaneous connections are 5, default values is 1.
Idle Timeout	When serial port stops data transmission for a defined period of time (Idle Timeout), the connection will be closed and the port will be freed and try to connect with other hosts. 0 indicate disable this function. Factory default value is 0. If Multilink is configured, only the first host connection is effective for this setting.
Alive Check	The serial device will send TCP alive-check package in each defined time interval (Alive Check) to remote host to check the TCP connection. If the TCP connection is not alive, the connection will be closed and the port will be freed. 0 indicate disable this function. Factory default is 0.

Table 5-9 Virtual COM

*\*Not allowed to mapping Virtual COM from web*

## Service Mode – TCP Server Mode

In TCP Server Mode, DS is configured with a unique Port combination on a TCP/IP network. In this case, DS waits passively to be contacted by the device. After a connection is established, it can then proceed with data transmission. TCP Server mode also supports up to 5 simultaneous connections, so that multiple device can receive data from the same serial device at the same time.



Serial Settings | Service Mode | Notification |

port1

Service Mode

TCP Server Mode

TCP Server Settings

Data Port

Control Port

Misc.

Idle Timeout  (0-65535) Seconds

Alive Check  (0-65535) Seconds

Multilink

Max Connections

Destination Host

1

2

3

4

5

Figure 5-13 TCP Server mode

The following table describes the labels in this screen.

Label	Description
Data Port	Set the port number for data transmission.
Auto Scan	Scan the data port automatically.
Idle Timeout	When serial port stops data transmission for a defined period of time (Idle Timeout), the connection will be closed and the port will be freed and try to connect with other hosts. 0 indicate disable this function. Factory default value is 0. If Multilink is configured, only the first host connection is effective for this setting.
Alive Check	The serial device will send TCP alive-check package in each defined time interval (Alive Check) to remote host to check the TCP connection. If the TCP connection is not alive, the connection will be closed and the port will be freed. 0 indicate disable this function. Factory default is 0.
Max Connection	The number of Max connection can support simultaneous connections are 5, default values is 1.

Table 5-10 TCP Server mode

## Service Mode – TCP Client Mode

In TCP Client Mode, device can establish a TCP connection with server by the method you have settled (Startup or any character). After the data has been transferred, device can disconnect automatically from the server by using the TCP alive check time or Idle time settings.

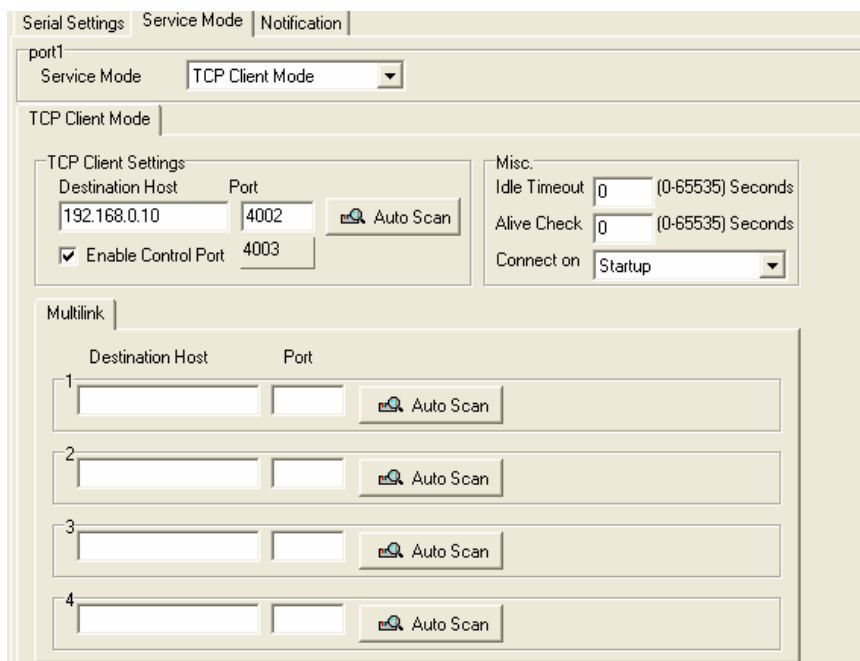

Figure 5-14 TCP Client mode

The following table describes the labels in this screen.

Label	Description
Destination Host	Set the IP address of host.
Port	Set the port number of data port.



Idle Timeout	When serial port stops data transmission for a defined period of time (Idle Timeout), the connection will be closed and the port will be freed and try to connect with other hosts. 0 indicate disable this function. Factory default value is 0. If Multilink is configured, only the first host connection is effective for this setting.
Alive Check	The serial device will send TCP alive-check package in each defined time interval (Alive Check) to remote host to check the TCP connection. If the TCP connection is not alive, the connection will be closed and the port will be freed. 0 indicate disable this function. Factory default is 0.
Connect on Startup	The TCP Client will build TCP connection once the connected serial device is started.
Connect on Any Character	The TCP Client will build TCP connection once the connected serial device starts to send data.

*Table 5-11 TCP Client mode*

### **Service Mode – UDP Mode**

Compared to TCP communication, UDP is faster and more efficient. In UDP mode, you can Uni-cast or Multi-cast data from the serial device server to host computers, and the serial device can also receive data from one or multiple host



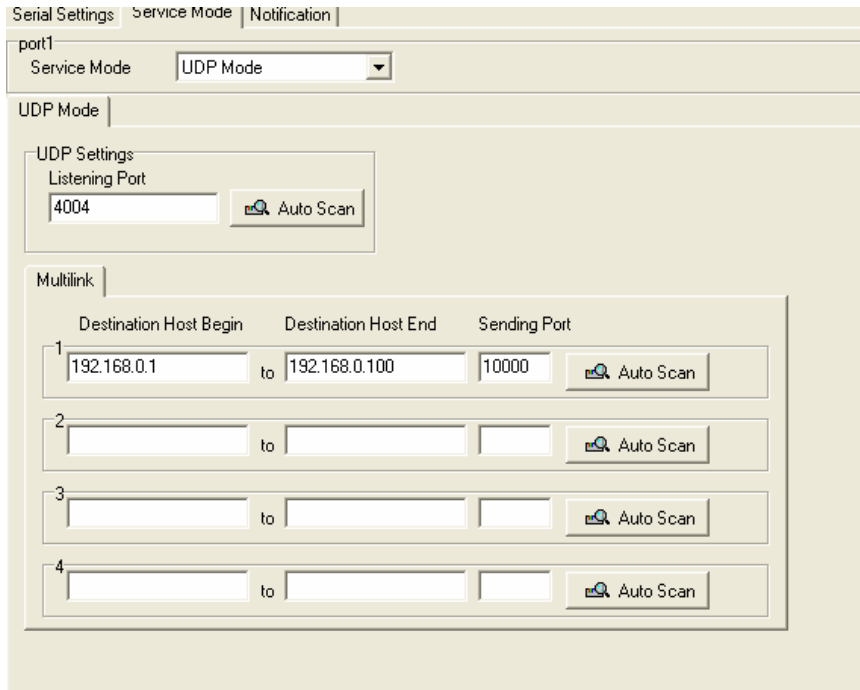

	Destination Host Begin	Destination Host End	Sending Port	
1	192.168.0.1	to 192.168.0.100	10000	Auto Scan
2		to		Auto Scan
3		to		Auto Scan
4		to		Auto Scan

Figure 5-15 UDP mode

## Notification

Specify the events that should be noticed. The events can be noticed by E-mail, SNMP trap or system log.

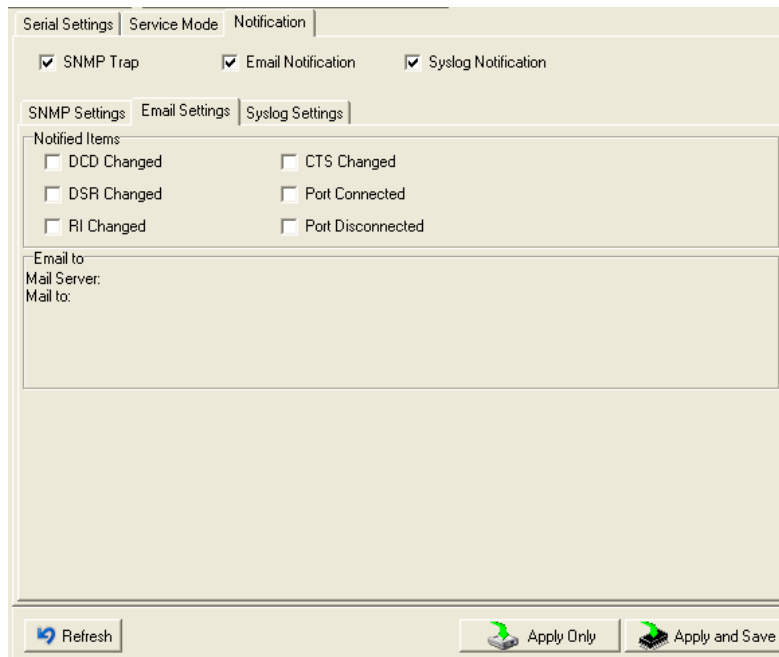

Figure 5-16 Notification

The following table describes the labels in this screen.

Label	Description
DCD changed	When DCD (Data Carrier Detect) signal changes, it indicates that the modem connection status has changed. Notification will be sent.
DSR changed	When DSR (Data Set Ready) signal changes, it indicates that the data communication equipment is powered off. A Notification will be sent.
RI changed	When RI (Ring Indicator) signal changes, it indicates that the incoming of a call. A Notification will be sent.
CTS changed	When CTS (Clear To Send) signal changes, it indicates that the transmission between computer and DCE can proceed. A notification will be sent.
Port connected	In TCP Server Mode, when the device accepts an incoming TCP connection, this event will be trigger. In TCP Client Mode, when the device has connected to the remote host, this event will be trigger. In Virtual COM Mode, Virtual COM is ready to use. A notification will be sent.

Port disconnected	In TCP Server/Client Mode, when the device lost the TCP link, this event will be trigger. In Virtual COM Mode, When Virtual COM is not available, this event will be trigger. A notification will be sent.
-------------------	---

Table 5-12 Notification

## 5.2 Configuration by Web Browser

### 5.2.1 CONNECT TO THE WEB PAGE

Step 1: Input the IP address of DS with “**https://192.168.10.2**” in the Address input box of IE.

Step 2: Click “**Yes**” button on the dialog box.



Figure 5-17 Certificate



Step 3: Input the name and password, then click "OK".

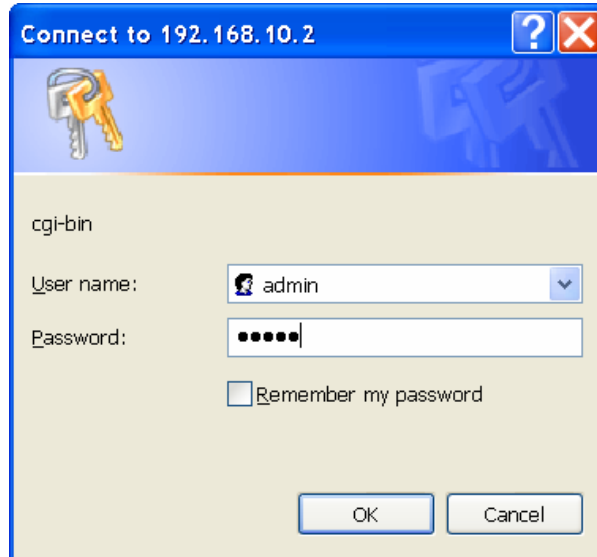

Figure 5-18 Certificate

*\*Only if password is set.*

Step 4: The system information will be shown as below.

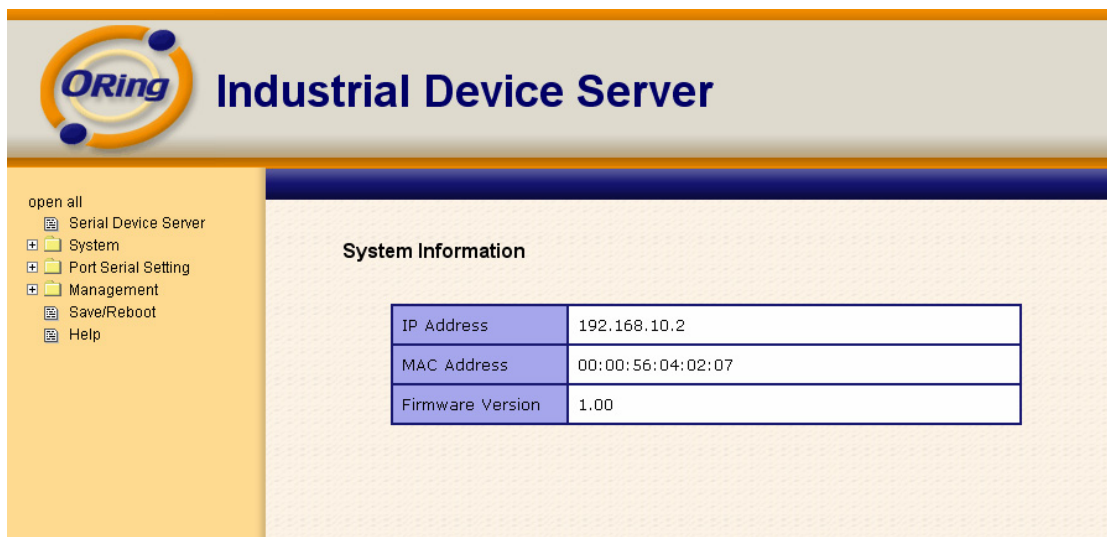

Figure 5-19 System information

## 5.2.1.1 System

### Time (SNTP)

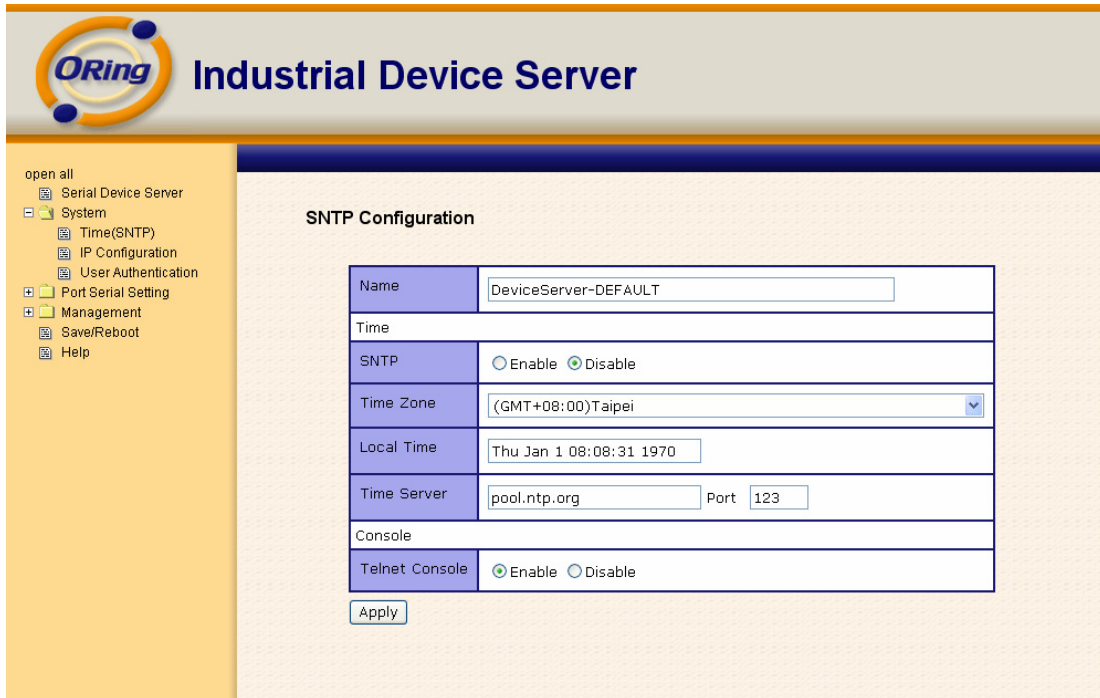

Figure 5-20 Time (SNTP)

The following table describes the labels in this screen.

Label	Description
Name	You can set the name of DS.
SNTP	Enable the SNTP server.
Time zone	After you set the SNTP enable, select the time zone you located.
Time server	Input SNTP server domain name or IP address and Port.
Console	Telnet Console (SSH) is included for security reasons. In some cases, you may need to disable this function to prevent unauthorized access from internet. The factory default is enable.

Table 5-13 Time (SNTP)



## IP Configuration

You must assign a valid IP address for DS before attached in your network environment. Your network administrator should provide you with the IP address and related settings. The IP address must be unique and within the network (otherwise, DS will not have a valid connection to the network). You can choose from three possible “**IP configuration**” modes: Static, DHCP/BOOTP. The Factory Default IP address is “**192.168.10.2**”

The screenshot shows the web interface for the ORing Industrial Device Server. The main heading is "IP Configuration". On the left is a navigation menu with the following items: "open all", "Serial Device Server", "System", "Time(SNTP)", "IP Configuration", "Wireless Configuration", "User Authentication", "Port Serial Setting", "Management", "Save/Reboot", and "Help". The main content area contains the following configuration fields:

Network Interface	LAN
IP Configuration	Static
IP Address	192.168.0.82
Netmask	255.255.255.0
Gateway	192.168.0.1
DNS Server 1	192.168.0.1
DNS Server 2	
Auto IP Report	
Auto Report to IP	
Auto Report to TCP Port	0
Auto Report Interval	0 seconds
Ethernet Mode	
Ethernet Mode	<input checked="" type="radio"/> Redundant <input type="radio"/> Switch

At the bottom of the form is an "Apply" button.

Figure 5-21 IP configuration



The following table describes the labels in this screen.

Label	Description
Network Type	Include LAN and Wireless.
DHCP/BOOTP	Obtain the IP address automatically from DHCP server.
Static IP Address	Assigning an IP address manually.
Subnet Mask	Set the subnet mask to communicate on the network.
Gateway	Enter the IP address of the router in you network.
DNS Server	Enter the IP address of the DNS server to translate domain names into IP address.
Auto IP Report	The device server will report its status periodically. At DS-Tool->IP collection option show the device server status. The report interval is 0 indicate disable this setting (default). But you can set the other IP or Port.
Switch Mode	<b>Redundant:</b> When the connection between master-link and LAN fails, the DS can automatically switch to another LAN port within10mS, and still guarantees a non-stop connection <b>Switch:</b> Daisy Chain support to reduce usage of switch ports.

Table 5-14 IP configurations



## Wireless configuration

Wireless Network include two mode: INFRA and ADHOC. The INFRA type connect the network by wireless access point, but the ADHOC is formed by the association of wireless and mobile devices capable of communicating among themselves even if there is no networking INFRA structure available.



Figure 5-22 Wireless configurations

The following table describes the labels in this screen.

Label	Description
Network Type	Type includes INFRA and ADHOC.
SSID	Service Set Identifier Default is the default setting. The SSID is a unique name that identifies a network. All devices on a network must share the same SSID name in order to communicate on the network.
Channel	All devices on the network must be set to the same channel to communicate on the network.



	You can select the Auto.
NO Encryption	You can set no encryption mode, but this mode is insecurity and don't suggest use.
WEP	You can set four encryption 5characters (WEP64), 13 characters (WEP128), 10 digits (WEP64), 26digits (WEP128).
TKIP	TKIP (Temporal Key Integrity Protocol) is a key management protocol.
AES	AES (Advanced Encryption System) is a variable bit length symmetric digital encryption algorithm.

*Table 5-15 Wireless Network setting*

*\*Simply unplug the RJ-45 to change into wireless connection*

## Authentication

You can set the password to prevent unauthorized access from network. Input the “**Old password**” and “**New password**” to change the password. Factory default is no password.

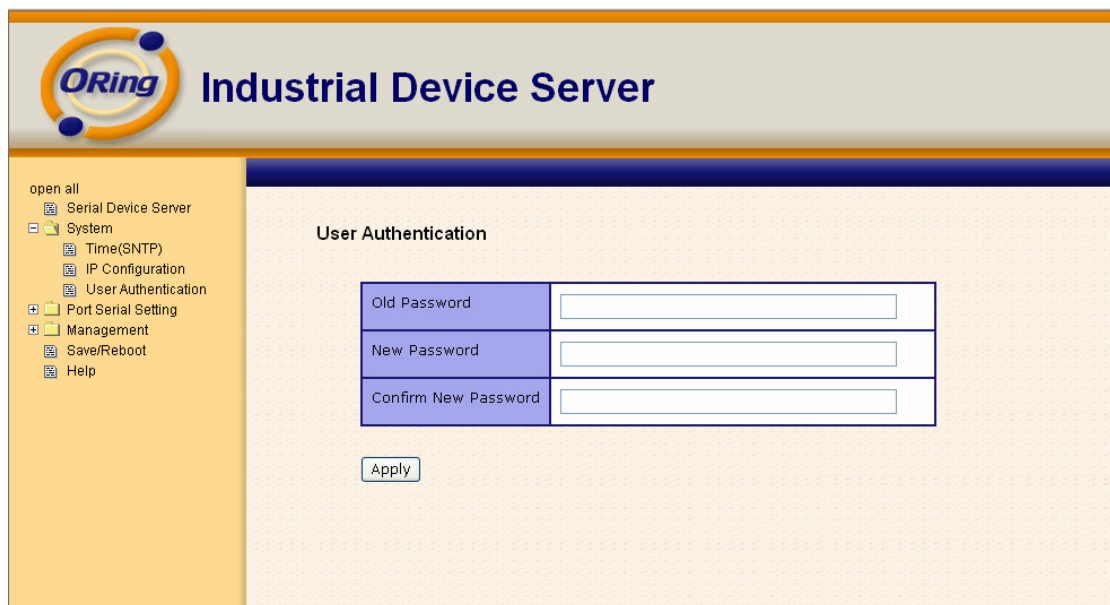

*Figure 5-22 Authentications*



### 5.2.1.2 Port serial setting

#### Serial configuration

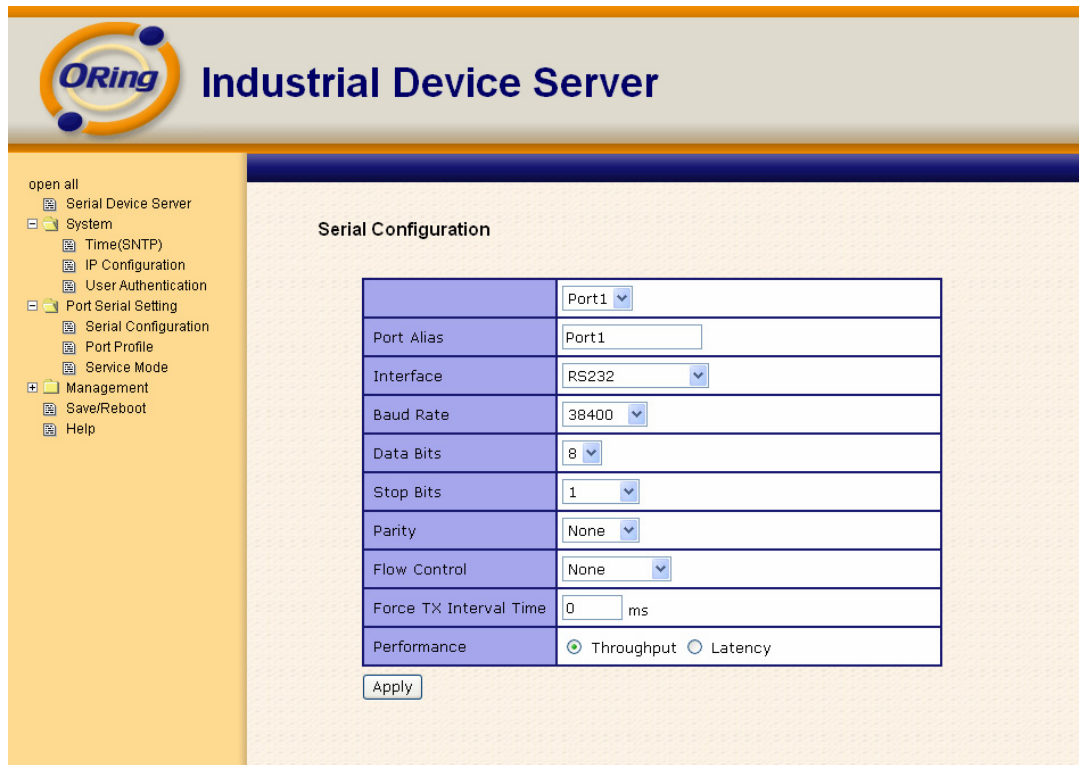

Figure 5-23 Serial configuration

The following table describes the labels in this screen.

Label	Description
Port Alias	Remark the port to hint the connected device.
Interface	RS232 / RS422 / RS485(2-wires) / RS485(4-wires)
Baud rate	110bps/300bps/1200bps/2400bps/4800bps/9600bps/19200bps/ 38400bps/57600bps/115200bps/230400bps/460800bps
Data Bits	5, 6, 7, 8
Stop Bits	1, 2 (1.5)

Parity	No, Even, Odd, Mark, Space
Flow Control	No, XON/XOFF, RTS/CTS, DTR/DSR
Force TX Interval Time	Force TX interval time is to specify the timeout when no data has been transmitted. When the timeout is reached or TX buffer is full (4K Bytes), the queued data will be sent. 0 means disable. Factory default value is 0.
Performance	Throughput: This mode optimized for highest transmission speed. Latency: This mode optimized for shortest response time.
Apply	Activate settings on this page.

Table 5-15 Serial configuration

### Port Profile

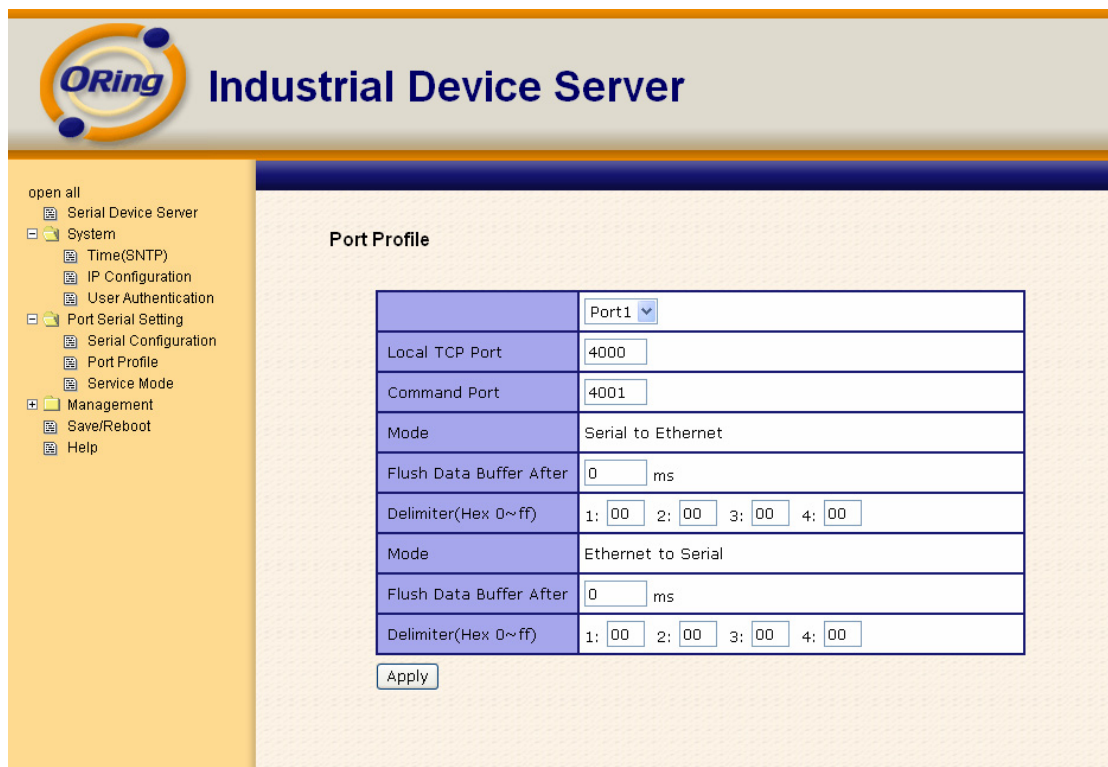

The screenshot shows the 'Port Profile' configuration page in the ORing Industrial Device Server web interface. The page title is 'Industrial Device Server' and the sub-page title is 'Port Profile'. A navigation menu on the left lists various system settings. The main configuration area contains a table with the following settings:

	Port1
Local TCP Port	4000
Command Port	4001
Mode	Serial to Ethernet
Flush Data Buffer After	0 ms
Delimiter(Hex 0~ff)	1: 00 2: 00 3: 00 4: 00
Mode	Ethernet to Serial
Flush Data Buffer After	0 ms
Delimiter(Hex 0~ff)	1: 00 2: 00 3: 00 4: 00

An 'Apply' button is located below the table.

Figure 5-24 Port Profile



The following table describes the labels in this screen.

Label	Description
Serial to Ethernet	<p><b>Flush Data Buffer After:</b></p> <p>The received data will be queued in the buffer until all the delimiters are matched. When the buffer is full (4K Bytes) or after "<b>flush S2E data buffer</b>" timeout, the data will also be sent. You can set the time from 0 to 65535 seconds.</p> <p><b>Delimiter:</b></p> <p>You can define max. 4 delimiters (00~FF, Hex) for each way. The data will be hold until the delimiters are received or the option "<b>Flush Serial to Ethernet data buffer</b>" times out. 0 means disable. Factory default is 0</p>
Ethernet to serial	<p><b>Flush Data Buffer After:</b></p> <p>The received data will be queued in the buffer until all the delimiters are matched. When the buffer is full (4K Bytes) or after "<b>flush E2S data buffer</b>" timeout, the data will also be sent. You can set the time from 0 to 65535 seconds.</p> <p><b>Delimiter:</b></p> <p>You can define max. 4 delimiters (00~FF, Hex) for each way. The data will be hold until the delimiters are received or the option "<b>Flush Ethernet to Serial data buffer</b>" times out. 0 means disable. Factory default is 0</p>

*Table 5-16 Port Profile*

## Service Mode – Virtual COM Mode

In Virtual COM Mode, the driver establishes a transparent connection between host and serial device by mapping the Port of the serial server serial port to local COM port on the host computer. Virtual COM Mode also supports up to 5 simultaneous connections, so that multiple hosts can send or receive data by the same serial device at the same time.

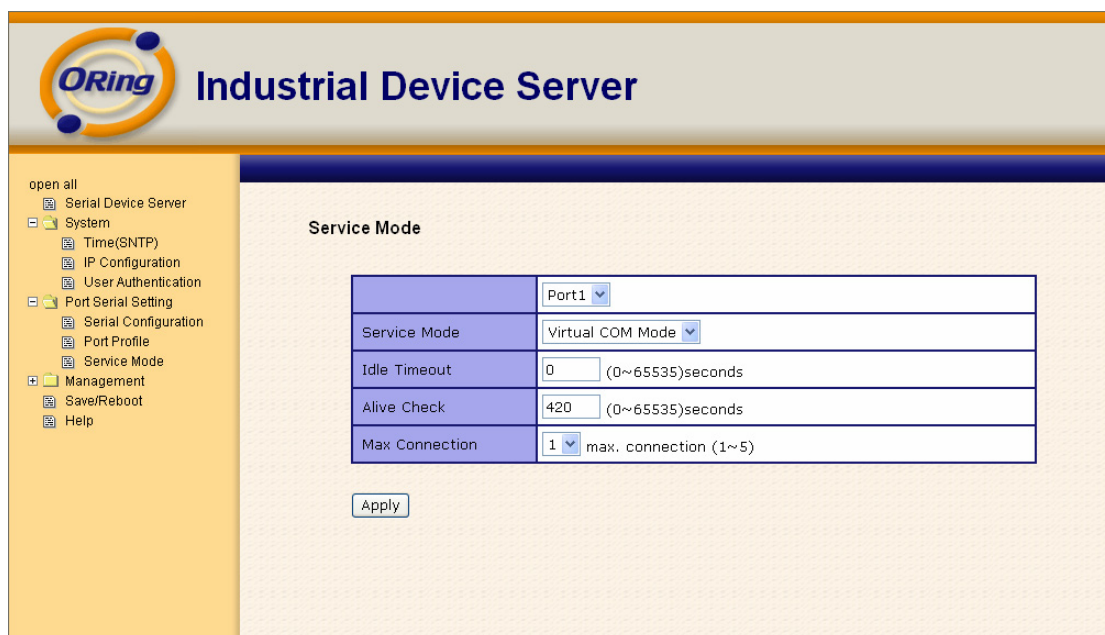

Figure 5-25 Virtual COM mode

The following table describes the labels in this screen.

Label	Description
Idle Timeout	When serial port stops data transmission for a defined period of time (Idle Timeout), the connection will be closed and the port will be freed and try to connect with other hosts. 0 indicate disable this function. Factory default value is 0. If Multilink is configured, only the first host connection is effective for this setting.



Alive Check	The serial device will send TCP alive-check package in each defined time interval (Alive Check) to remote host to check the TCP connection. If the TCP connection is not alive, the connection will be closed and the port will be freed. 0 indicate disable this function. Factory default is 0.
Max Connection	The number of Max connection can support simultaneous connections are 5, default values is 1.

Table 5-17 Virtual COM mode

\*Not allowed to mapping Virtual COM from web

### Service Mode – TCP Server Mode

In TCP Server Mode, DS is configured with a unique Port combination on a TCP/IP network. In this case, DS waits passively to be contacted by the device. After the device establishes a connection with the serial device, it can then proceed with data transmission. TCP Server mode also supports up to 5 simultaneous connections, so that multiple device can receive data from the same serial device at the same time.

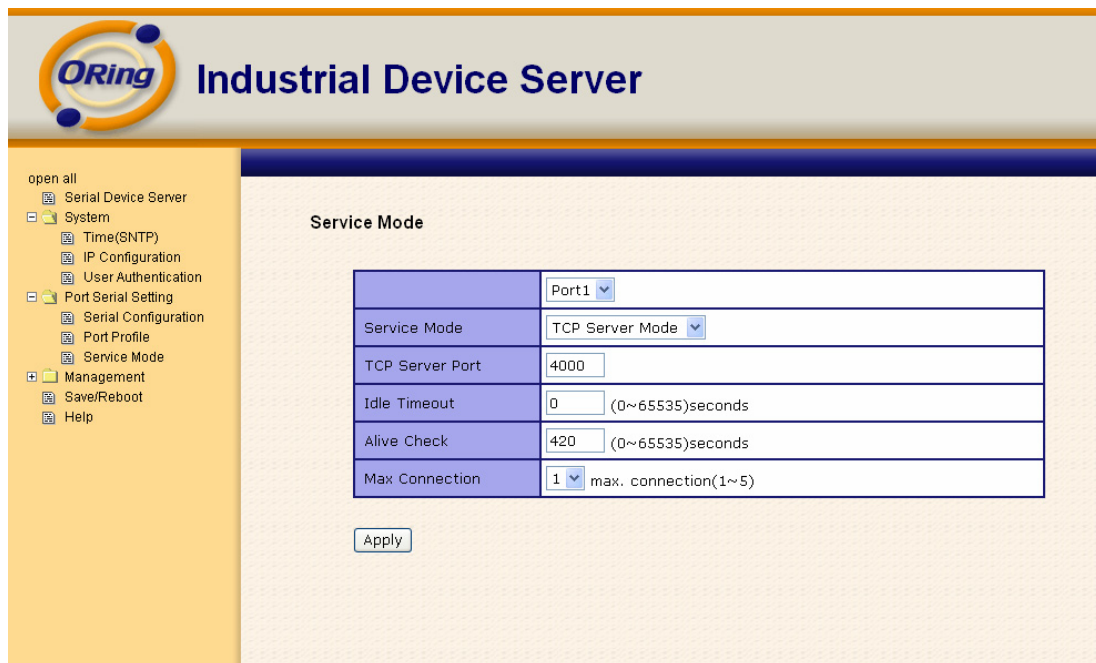

Figure 5-26 TCP Server Mode



The following table describes the labels in this screen.

Label	Description
TCP Server Port	Set the port number for data transmission.
Idle Timeout	When serial port stops data transmission for a defined period of time (Idle Timeout), the connection will be closed and the port will be freed and try to connect with other hosts. 0 indicate disable this function. Factory default value is 0. If Multilink is configured, only the first host connection is effective for this setting.
Alive Check	The serial device will send TCP alive-check package in each defined time interval (Alive Check) to remote host to check the TCP connection. If the TCP connection is not alive, the connection will be closed and the port will be freed. 0 indicate disable this function. Factory default is 0.
Max Connection	The number of Max connection can support simultaneous connections are 5, default values is 1.

Table 5-18 TCP server mode

### Service Mode – TCP Client Mode

In TCP Client Mode, device can establish a TCP connection with server by the method you set (Startup or any character). After the data has been transferred, device can disconnect automatically from the server by using the TCP alive check time or Idle timeout settings.





Figure 5-27 TCP client mode

The following table describes the labels in this screen.

Label	Description
Destination Host	Set the IP address of host and the port number of data port.
Idle Timeout	When serial port stops data transmission for a defined period of time (Idle Timeout), the connection will be closed and the port will be freed and try to connect with other hosts. 0 indicate disable this function. Factory default value is 0. If Multilink is configured, only the first host connection is effective for this setting.
Alive Check	The serial device will send TCP alive-check package in each defined time interval (Alive Check) to remote host to check the TCP connection. If the TCP connection is not alive, the connection will be closed and the port will be freed. 0 indicate disable this function. Factory default is 0.
Connect on Startup	The TCP Client will build TCP connection once the connected serial device is started.



Connect on Any Character	The TCP Client will build TCP connection once the connected serial device starts to send data.
--------------------------	--

Table 5-19 TCP client mode

## Service Mode – UDP Client Mode

Compared to TCP communication, UDP is faster and more efficient. In UDP mode, you can Uni-cast or Multi-cast data from the serial device server to host computers, and the serial device can also receive data from one or multiple host

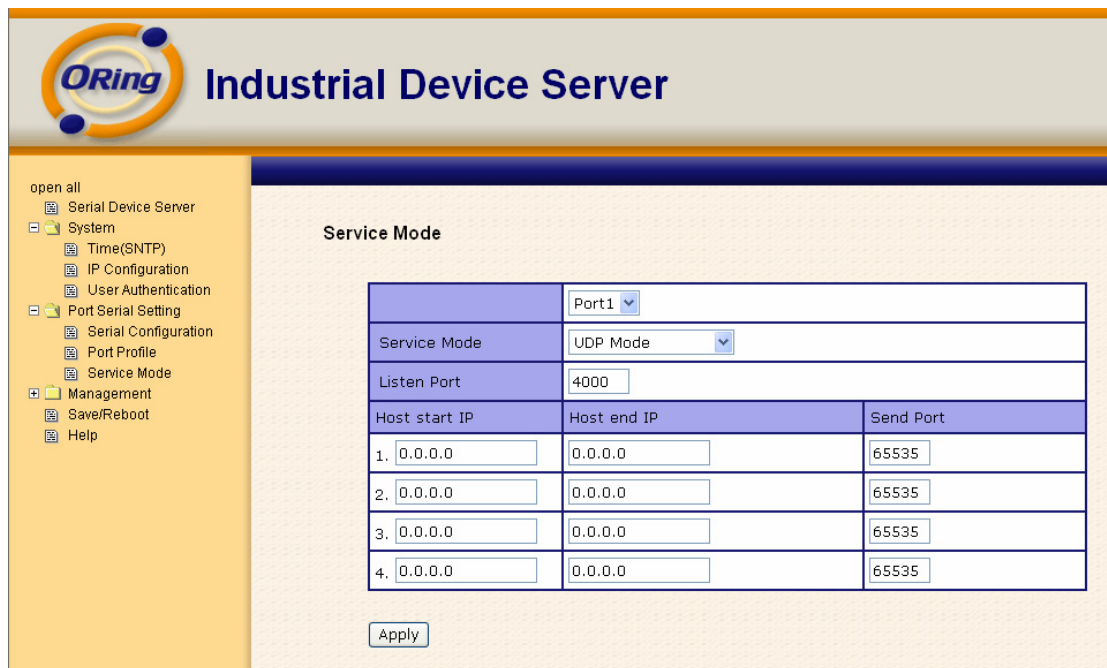

Figure 5-28 UDP client mode



### 5.2.1.3 Management

#### Access IP Control

Access IP Control Settings allow you to add or block the remote host IP addresses to prevent unauthorized access. If host's IP address is in the accessible IP table, then the host will be allowed to access the DS. You can choose one of the following cases by setting the parameter.

1. Only one host with a special IP address can access the device server, "IP address /255.255.255.255" (e.g., "192.168.0.1/255.255.255.255").
2. Hosts on a specific subnet can access the device server. "IP address/255.255.255.0" (e.g., "192.168.0.2/255.255.255.0")
3. Any host can access the device server. Disable this function by un-checking the "Enable IP Filter" checkbox

The screenshot shows the 'Access IP Control List' configuration page in the ORing Industrial Device Server web interface. On the left is a navigation menu with categories like 'Serial Device Server', 'System', 'Port Serial Setting', 'Serial Configuration', 'Service Mode', 'Management', and 'Help'. The main content area features a checkbox for 'Enable IP Filtering (Not check this option will allow any IP to have assessibility)'. Below this is a table with 16 rows for configuring individual IP access rules.

No.	Activate the IP	IP Address	Netmask
1	<input type="checkbox"/>	<input type="text"/>	<input type="text"/>
2	<input type="checkbox"/>	<input type="text"/>	<input type="text"/>
3	<input type="checkbox"/>	<input type="text"/>	<input type="text"/>
4	<input type="checkbox"/>	<input type="text"/>	<input type="text"/>
5	<input type="checkbox"/>	<input type="text"/>	<input type="text"/>
6	<input type="checkbox"/>	<input type="text"/>	<input type="text"/>
7	<input type="checkbox"/>	<input type="text"/>	<input type="text"/>
8	<input type="checkbox"/>	<input type="text"/>	<input type="text"/>
9	<input type="checkbox"/>	<input type="text"/>	<input type="text"/>
10	<input type="checkbox"/>	<input type="text"/>	<input type="text"/>
11	<input type="checkbox"/>	<input type="text"/>	<input type="text"/>
12	<input type="checkbox"/>	<input type="text"/>	<input type="text"/>
13	<input type="checkbox"/>	<input type="text"/>	<input type="text"/>
14	<input type="checkbox"/>	<input type="text"/>	<input type="text"/>
15	<input type="checkbox"/>	<input type="text"/>	<input type="text"/>
16	<input type="checkbox"/>	<input type="text"/>	<input type="text"/>

Figure 5-29 Access IP

## SMTP/SNMP Conf

Email Server configuration includes the mail server's IP address or domain. If the authentication is required, specify your name and password. There are 4 Email addresses that you can specify to receive the notification.

SNMP Server configuration includes the SNMP Trap Server IP address, Community, Location and Contact. There are 4 SNMP addresses you can specify to receive the notification.

SysLog server configuration includes the server IP and server Port. This option need to use with DS-Tool.



**ORing Industrial Device Server**

SMTP/SNMP Configuration

E-mail Settings	
SMTP Server	<input type="text"/> Port <input type="text"/>
<input type="checkbox"/> My server requires authentication	
User Name	<input type="text"/>
Password	<input type="text"/>
E-mail Sender	<input type="text"/>
E-mail Address 1	<input type="text"/>
E-mail Address 2	<input type="text"/>
E-mail Address 3	<input type="text"/>
E-mail Address 4	<input type="text"/>
SNMP Trap Server	
SNMP Server 1	<input type="text"/>
SNMP Server 2	<input type="text"/>
SNMP Server 3	<input type="text"/>
SNMP Server 4	<input type="text"/>

Figure 5-30SMTP / SNMP conf



### System Event Conf.

Specify the events that should be notified to the administrator. The events can be alarmed by E-mail, SNMP trap, or system log.



Figure 5-31 SMTP / SNMP conf

The following table describes the labels in this screen.

Label	Description
Hardware Reset (Cold Start)	This refers to starting the system from power off (contrast this with warm start). When performing a cold start, DS will automatically issue an Auto warning message by sending E-mail, log information or an SNMP trap after booting.



Software Reset (Warm Start)	This refers to restart the computer without turning the power off. When performing a warm start, DS will automatically send an E-mail, log information or SNMP trap after reboot.
Login Failed	When an unauthorized access from the Console or Web interface, a notification will be sent.
IP Address Changed	When IP address of device changed, a notification will be sent.
Password Changed	When password of device changed, a notification will be sent.
Access IP Blocked	When the host accesses the device with blocked IP addresses, a notification will be sent.
Redundant Power Change	When status of power changed, a notification will be sent.
Redundant Ethernet Change	When status of Ethernet port changed, a notification will be sent.
DCD changed	When DCD (Data Carrier Detect) signal changes, it indicates that the modem connection status has been changed. A Notification will be sent.
DSR changed	When DSR (Data Set Ready) signal changes, it indicates that the data communication equipment is powered off. A Notification will be sent.
RI changed	When RI (Ring Indicator) signal changes, it indicates an incoming call. Notification will be sent.
CTS changed	When CTS (Clear To Send) signal changes, it indicates that the transmission between computer and DCE can proceed. A notification will be sent.
Port connected	In TCP Server Mode, when the device accepts an incoming TCP connection, this event will be trigger. In TCP Client Mode, when the device has connected to the remote host, this event will be trigger. In Virtual COM Mode, Virtual COM is ready to use. A notification will be sent.
Port disconnected	In TCP Server/Client Mode, when the device lost the TCP link, this event will be trigger. In Virtual COM Mode, When Virtual COM is not available, this event will be trigger. A notification will be sent.
Power 1 Fault	When Power 1 Fault, a notification will be sent and the Fault LED will be lighted.
Power 2 Fault	When Power 2 Fault, a notification will be sent and Fault LED will be lighted.



Eth1 link down	When Eth1 link down, a notification will be sent and Fault LED will be lighted.
Eth2 link down	When Eth2 link down, a notification will be sent and Fault LED will be lighted.

Table 5-20 System event conf

### 5.2.1.4 Save/Reboot

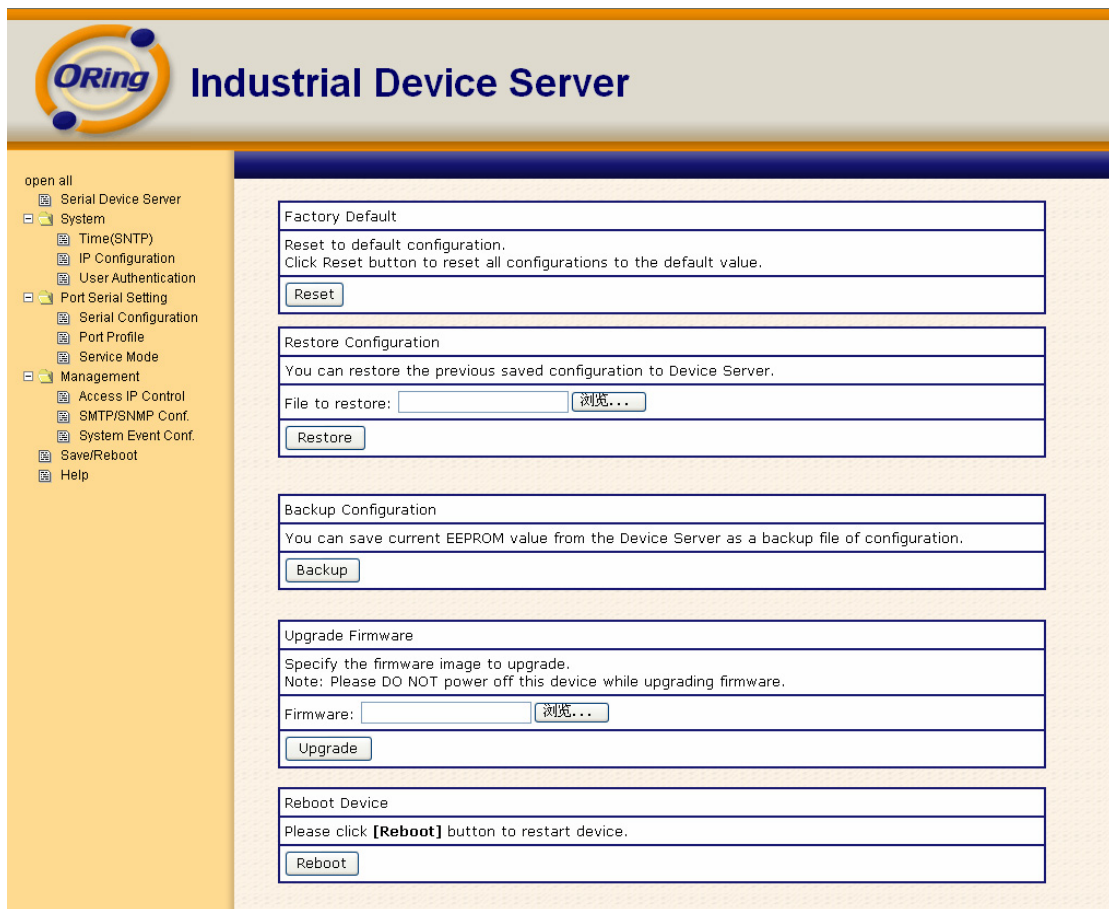

Figure 5-32 Save / Reboot

The following table describes the labels in this screen.

Label	Description
Factory Default	Load default configuration except settings of Network. If you want load all factory default, you should press "Reset" button about the five seconds on the device (Hardware restore).
Restore Configuration	Restore the previous exported configuration.
Backup Configuration	Export the current configuration to a file.
Upgrade Firmware	Upgrade to a new firmware with specified file.
Reboot Device	Reboot the device server (warm start).

Table 5-21 Save / Reboot

## 5.3 Configuration by SSH Console

### 5.3.1 Connect to DS

You can use SSH Tool (e.g., PUTTY) to access SSH console of DS. The SSH console interface is shown below.

```

login as: admin
admin@192.168.0.39.'s password:

*****
*** ORING Industrial Serial Device Server Commander ***
*****
-----
[ORING Industrial Serial Device Server Commander]
1. Overview
2. General Settings
3. Network Settings
4. Ports settings
5. Security(Accessible IP) Settings
6. Notification(Auto Warning) Settings
C. Change Password
L. Load Factory Default
S. Save configuration
R. Reboot
Q. Exit & Logout

Select one function (1-6,C,L,S,R,Q): █
  
```

Figure 5-33 SSH



# Technical Specifications

<b>Network Interface</b>	
Ethernet	2x 10/100Base-T(X) which support Redundant Dual Ethernet or Switch Mode support. Auto-recover less than 10ms
connector	RJ-45
Protection	Built-in 1.5KV magnetic isolation
Protocols	ICMP, IP, TCP, UDP, DHCP, BOOTP, ARP/RARP, DNS, SNMP MIB II, HTTPS, SSH
<b>WLAN Feature</b>	
Operating Mode	Client mode
Antenna Connector	Reverse SMA
Radio Frequency Type	DSSS
Modulation	IEEE802.11b: CCK, DQPSK, DBPSK IEEE802.11g: OFDM with BPSK, QPSK, 16QAM, 64QAM
Frequency Band	America/FCC: 2.412~2.462 GHz (11 channels) Europe CE/ETSI: 2.412~2.472 GHz (13 channels)
Transmission Rate	IEEE802.11b: 1/ 2/ 5.5/ 11 Mbps IEEE802.11g: 6/ 9/ 12/ 18/ 24/ 36/ 48/ 54 Mbps
Transmit Power	IEEE802.11b/g: 18dBm
Receiver Sensitivity	-81dBm @ 11Mbps, PER< 8%; -64dBm @ 54Mbps, PER< 10%
Encryption Security	WEP: (64-bit , 128-bit key supported) WPA: WPA2 :802.11i(WEP and AES encryption) PSK (256-bit key pre-shared key supported) 802.1X and Radius





	supported TKIP encryption
Wireless Security	SSID broadcast disable
<b>Serial Interface</b>	
Interface	IDS-5042-WG 4x RS232 / RS422 / 4(2)-Wire RS485. Which can be configured by DS-Tool IDS-5042-IWG-I+: 4x RS422 / 4(2)-Wire RS485. Which can be configured by DS-Tool
Connector	IDS-5042-WG: Male DB9 IDS-5042-IWG-I+: 5 pin terminal block
Serial Baud Rate	110 bps to 460.8 Kbps
Data Bits	5, 6, 7, 8
Parity	odd, even, none, mark, space
Stop Bits	1, 1.5, 2
RS-232 signals	TxD, RxD, RTS, CTS, DTR, DSR, DCD, RI, GND (IDS-5042-WG / 5042-IWG/IDS-5042-WG / 5042-IWG+)
RS-422 signals	Tx+,Tx-, Rx+, Rx-,GND
RS-485 (4 wire) signals	Tx+,Tx-, Rx+, Rx-,GND
RS-485 (2 wire) signals	Data+, Data-,GND
Flow control	XON/XOFF, RTS/CTS, DTR/DSR
Serial Line Protection	Built-in15KV ESD protection 2KV DC isolation for each port (IDS-5042-WG / 5042-IWG-IW only)



LED Indicators	<p>PWR 1(2) / Ready:</p> <p>1)Red On: Power is on and booting up. Red Blinking: Indicates an IP conflict, or DHCP or BOOTP server did not respond properly.</p> <p>2) Green On: Power is on and functioning normally. Green Blinking: Located by Administrator.</p>
	<p>ETH1(2) Link / ACT:</p> <p>Orange ON/Blinking: 10 Mbps Ethernet Green ON/Blinking:100 Mbps Ethernet</p>
	<p>Serial TX / RX LEDs:</p> <p>Red: Serial port is receiving data Green: Serial port is transmitting data.</p>
	<p>Fault: Fault alarm (Red)</p>
	<p>WLAN LED: ON/Blinking: WLAN LNK/ACT</p>
	<p>WLAN Signal:</p> <p>Green ON : 4 / 3 / 2 / 1 / 0 LED(s) correspond to WLAN signal strength 100% / 75% / 50% / 25% / BAD</p>
<b>Power Requirements</b>	
Power Input	PWR1/2: 12~48VDC in 6-pin Terminal Block
Reverse Polarity Protection	Present at terminal block
Power Consumption	7 Watts MAX
<b>Software Utility</b>	
Utility	DS-Tool for Windows NT/2000/XP/ 2003/VISTA which include Device discovery Auto IP report



	<p>Device setting (run-time change, no rebooting)</p> <p>Access control list</p> <p>Group setting</p> <p>Device monitoring</p> <p>Serial port monitoring</p> <p>Log info</p> <p>Group Firmware update</p>
Serial Mode	<p>Virtual Com / TCP Server / TCP Client / UDP /Serial Tunnel</p> <p>TCP Alive Check Timeout</p> <p>Inactivity Timeout</p> <p>Delimiter for Data Packing</p> <p>Force TX Timeout for Data Packing</p>
Multiple Link	<p>5 Hosts simultaneous connection: Virtual Com / TCP server / TCP Client / UDP</p>
VCOM Driver	<p>Windows NT/2000/XP/2003/VISTA</p>
Configuration	<p>Web HTTPS console, SSH console, Console Command</p> <p>DS-Tool for Windows</p> <p>NT/2000/XP/VISTA</p>
<b>Environmental</b>	
Operating Temperature	-10 to 55°C (14 to 131°F)
Operating Humidity	5% to 95%(Non-condensing)
Storage Temperature	-20 to 85°C (-4 to 185°F)
<b>Mechanical</b>	
Dimensions(W x D x H)	52mm(W)x106mm(D)x144mm(H)
Casing	IP-30 protection
<b>Regulatory Approvals</b>	
Shock	IEC 60068-2-27
Free Fall	IEC 60068-2-32
Vibration	IEC 60068-2-6
EMI	FCC Part 15, CISPR (EN55022) class A



EMS	EN61000-4-2 (ESD), EN61000-4-3 (RS) EN61000-4-4 (EFT) EN61000-4-5 (Surge) EN61000-4-6 (CS)
Warranty	5 years