

Quick Installation Guide

TES-180-M12



EN50155 8-port unmanaged
Ethernet switch

Introduction

The TES-180-M12 unmanaged Ethernet switch is designed for industrial applications, such as rolling stock, vehicle, and railway applications. The switch boasts EN50155 compliance and M12 connectors to ensure tight and robust connections, and guarantee reliable operation against environmental disturbances, such as vibration and shock. With eight 10/100Base-T(X) ports, the switch provides a wide operating temperature range from -40°C to 70°C.

Package Contents





The device is shipped with the following items. If any of these items is missing or damaged, please contact your customer service representative for assistance.

Contents	Pictures	Number
TES-180-M12		1
QIG		1

Preparation

Before you begin installing the device, make sure you have all of the package contents available and a PC with Microsoft Internet Explorer 6.0 or later, for using web-based system management tools.

Safety & Warnings

-  **Elevated Operating Ambient:** If installed in a closed environment, make sure the operating ambient temperature is compatible with the maximum ambient temperature (T_{ma}) specified by the manufacturer.
-  **Reduced Air Flow:** Make sure the amount of air flow required for safe operation of the equipment is not compromised during installation.
-  **Mechanical Loading:** Make sure the mounting of the equipment is not in a hazardous condition due to uneven mechanical loading.
-  **Circuit Overloading:** Consideration should be given to the connection of the equipment to the supply circuit and the effect that overloading of the circuits might have on overcurrent protection and supply wiring. Appropriate consideration of equipment nameplate ratings should be used when addressing this concern.

Dimension

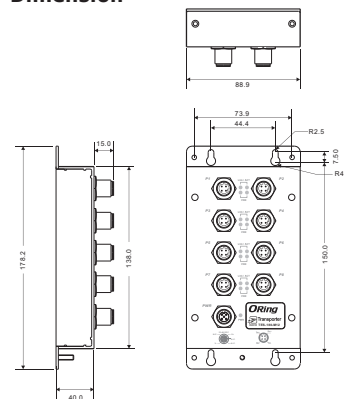

Panel Layouts

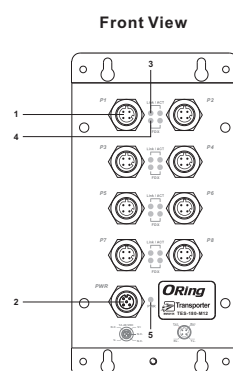

1. Ethernet port
2. Power port
3. LNK/ACT LED for LAN ports
4. Duplex/Collision LED for LAN ports
5. Power status LED

Installation

Wall-mount

The device can be fixed to the wall. Follow the steps below to install the device on the wall.

Step 1: Hold the device upright against the wall

Step 2: Insert four screws through the large opening of the keyhole-shaped apertures at the top and bottom of the unit and fasten the screw to the wall with a screwdriver.

Step 3: Slide the device downwards and tighten the four screws for added stability.

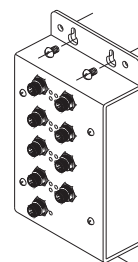

Instead of screwing the screws in all the way, it is advised to leave a space of about 2mm to allow room for sliding the switch between the wall and the screws.

Wiring

Power port pinouts

The device supports power supply in M12 5-pin female connector on the front panel for the dual power inputs.

Step 1: Insert a power cable to the power connector on the device.
Step 2: Rotate the outer ring of the cable connector until a snug fit is achieved. Make sure the connection is tight.



Network Connection

The switch has eight 10/100Base-T(X) Ethernet ports in the form of M12 connector. Depending on the link type, the switch uses CAT 3, 4, 5, 5e UTP cables to connect to network devices (PCs, servers, switches, routers, or hubs). Please refer to the following table for cable specifications.

Cable	Type	Max. Length	Connector
10BASE-T	Cat. 3, 4, 5 100-ohm	UTP 100 m (328 ft)	4-pin female M12 D-coding connector
100BASE-TX	Cat. 5 100-ohm UTP	UTP 100 m (328 ft)	4-pin female M12 D-coding connector

M12/4P Pin Definition

For pin assignments of the LAN ports, please refer to the following tables.



Pin No.	Description
#1	RD+
#2	TD+
#3	RD-
#4	TD-

Configurations

After installing the switch and connecting cables, start the device by turning on power. The green power LED should turn on. Please refer to the following table for LED indication.

LED	Color	Status	Description
PWR	Green	On	DC power module is activated
10/100Base-T(X)			
LNK/ACT	Green	On	Port is Linked
		Blinking	Transmitting data
Duplex / Collision	Amber	On	Port is in duplex mode
		Blinking	Collision occurs

Specifications

ORing Switch Model	TES-180-M12
Physical Ports	
10/100Base-T(X) Ports in M12	8 x M12 connector (4 pin D-coding)
Technology	
Ethernet Standards	IEEE 802.3 for 10Base-T IEEE 802.3u for 100Base-TX IEEE 802.3x for Flow control
MAC Table	8192 MAC addresses
Processing	Store-and-Forward
LED Indicators	
Power Indicator	Green: Power LED x 1
10/100Base-T(X) M12 Port Indicator	Green for port Link/Act. Amber for Duplex/Collision
Power	
Redundant Input Power	12~48VDC on M12 connector
Power Consumption(Typ.)	4.32 Watts
Overload Current Protection	Present
Reverse Polarity Protection	Present
Physical Characteristic	
Enclosure	IP-40
Dimension (W x D x H)	88.9 (w) x 40 (D) x 178.2 (H) mm (3.5 x 1.57 x 7.02 inch.)
Weight (g)	510 g
Environmental	
Storage Temperature	-40 to 85°C (-40 to 185°F)
Operating Temperature	-40 to 70°C (-40 to 158°F)
Operating Humidity	5% to 95% Non-condensing
Regulatory Approvals	
EMI	FCC Part 15, CISPR (EN55022) class A, EN50155 (EN50121-3-2, EN55011, EN50121-4)
EMS	EN61000-4-2 (ESD), EN61000-4-3 (RS), EN61000-4-4 (EFT), EN61000-4-5 (Surge), EN61000-4-6 (CS), EN61000-4-8, EN61000-4-11
Shock	IEC60068-2-27
Free Fall	IEC60068-2-32
Vibration	IEC60068-2-6
Safety	EN60950-1
Warranty	5 years



Copyright© 2014 ORing
All rights reserved.



ORing Industrial Networking Corp.

TEL: +886-2-2218-1066 Website: www.oring-networking.com
FAX: +886-2-2218-1014 E-mail: support@oring-networking.com