

PXI-7921
24-CH, Multiplexer DPDT Relay Module
User's Manual



Recycled Paper

© Copyright 2004 ADLINK Technology Inc.

All Rights Reserved.

Manual Rev. 1.00: July 9, 2004

Part Number: 50-17011-100

The information in this document is subject to change without prior notice in order to improve reliability, design, and function and does not represent a commitment on the part of the manufacturer.

In no event will the manufacturer be liable for direct, indirect, special, incidental, or consequential damages arising out of the use or inability to use the product or documentation, even if advised of the possibility of such damages.

This document contains proprietary information protected by copyright. All rights are reserved. No part of this manual may be reproduced by any mechanical, electronic, or other means in any form without prior written permission of the manufacturer.

Trademarks

NuDAQ[®], NuIPC[®], NuDAM[®], NuPRO[®] are registered trademarks of ADLINK Technology Inc. Other product names mentioned herein are used for identification purposes only and may be trademarks and/or registered trademarks of their respective companies.

Getting Service from ADLINK

Customer Satisfaction is top priority for ADLINK Technology Inc. If you need any help or service, please contact us.

ADLINK TECHNOLOGY INC.			
Web Site	http://www.adlinktech.com		
Sales & Service	Service@adlinktech.com		
TEL	+886-2-82265877	FAX	+886-2-82265717
Address	9F, No. 166, Jian Yi Road, Chungo City, Taipei, 235 Taiwan		

Please email or FAX your detailed information for prompt, satisfactory, and consistent service.

Detailed Company Information			
Company/Organization			
Contact Person			
E-mail Address			
Address			
Country			
TEL		FAX	
Web Site			
Questions			
Product Model			
Environment	OS: Computer Brand: M/B: CPU: Chipset: BIOS: Video Card: NIC: Other:		
Detail Description			
Suggestions for ADLINK			

Table of Contents

Chapter 1 Introduction	1
1.1 Features	1
1.2 Applications	2
1.3 Specifications	2
1.4 Software Support	3
Chapter 2 Installation	5
2.1 Contents	5
2.2 Unpacking	5
2.3 Mechanical Drawing.....	6
2.4 Installing the switch module into a PXI Platform.....	6
Chapter 3 Signal Connection	9
3.1 PXI-7921 Topology	9
3.2 PXI-7921 Pin Assignments & Descriptions.....	10
3.3 TB-6221 Terminal Board	13
2-wire MUX.....	14
2-wire, 2-group MUX	15
2-wire, 4-group MUX	16
1-wire MUX.....	17
4-wire MUX.....	18
Chapter 4 Operation Theorem	19
4.1 Hardware Block Diagram	19
4.2 Operation Mode	20
4.3 Handshaking	20
4.4 Trigger Bus	24
4.5 Star Trigger	25
4.6 Auxiliary Digital I/O	26
4.7 Hot-Swap	27
4.8 Emergency Shutdown	27
4.9 Watchdog Timer	28
Warranty Policy	31

How to Use This Manual

This User Manual is designed to assist users in the installation of the ADLINK PXI-7921, 24-CH Multiplexer DPDT Relay PXI Switch module.

- Chapter 1 **Introduction**
Gives an outline and overview of ADLINK switch modules' features, specifications, and applications.
- Chapter 2 **Installation**
Describes how to install a switch module into a PXI chassis. For software library and utilities installation, please refer to the Software Users' Guide.
- Chapter 3 **Signal Connection**
Shows the pin assignments and terminal board connection of the switch module.
- Chapter 4 **Operation Theorem**
Describes function blocks on ADLINK switch modules and operation instructions.

Introduction

ADLINK PXI-7921 is a relay multiplexer module which consists of 24 2-wire relays (DPDT, 2 Form C). PXI-7921 provides 48x1 1-wire and 24x1 2-wire and 12x1 4-wire configurations and typically connects one instrument, such as a DMM, a digitizer or a signal source, with many points which need measurement or excitation.

Relays of PXI-7921 can be updated by either direct-update mode or auto-scan mode. The latter mode supports scanlist of 1k-sample for deterministic scanning.

PXI trigger functions are fully supported and software programmable. The multiple switch modules can be synchronized and triggered without additional field wiring.

For safety critical applications, PXI-7921 module can switch to the preset state by either asserting emergency shutdown manually, or watchdog timer overflow event.

1.1 Features

- PXI specifications Rev. 2.0 compliant
- 3U Eurocard form factor, CompactPCI compliant (PICMG 2.0 R3.0)
- PICMG 2.1 R2.0 CompactPCI Hot-Swap specifications compliant
- 24-CH DPDT (2 Form C) non-latching relays
- Contact rating
 - 2A switching, 2A carrying
 - 220V_{DC}, 125V_{AC}
- 125 operations per second
- 1k-sample scanlist for deterministic scanning
- Provides handshaking signals to trigger external instruments
- Programmable emergency shutdown function and Watchdog timer for safety critical applications
- Three auxiliary 3.3V/TTL digital inputs/outputs with 5V tolerance
- Supports PXI backplane triggers to synchronize multiple modules
- Fully software programmable

1.2 Applications

- Industrial ON/OFF control
- External high power relay driving and signal switching
- Laboratory automation
- Industrial automation
- Switch contact status sensing
- Limit switch monitoring
- Cooperating with other modules such as A/D and D/A peripherals to implement a data acquisition and control system

1.3 Specifications

Relay Output

- Number of channels: 24
- Relay type: DPDT (2 Form C), non-latching
- Switching capacity:
 - Max. switching current: 2A
 - Max. switching voltage: 220V_{DC}, 125V_{AC}
 - Max. switching power: 50VA, 60W
 - ◆ Max. carrying current: 2A
- Failure rate: 10 μ A
- Contact resistance: 100m Ω max.
- Relay set/reset time
 - Operate time: 4ms max.
 - Release time: 4ms max.
 - Bounce time: 1ms max.
- Expected life:
 - Mechanical life: 10⁸ operations min.
 - Electrical life: 5x10⁵ operations min. (1A @ 30V_{AC}, resistive load)
- Data transfer: Programmed I/O

Auxiliary Digital I/O

- Numbers of channel: 3 inputs/outputs
- Compatibility: 3.3 V/TTL (5V tolerant)
- Data transfers: programmed I/O

Handshaking Signals

- Programmable polarity
- Logic level: 3.3 V/TTL (5V tolerant)
- Trigger In source: TRG_IN, PXI trigger bus, PXI star trigger in
- Scanner Advanced destination: S_ADV, PXI trigger bus, PXI star trigger out

Safety functions

- Emergency shutdown
 - Logic level: 3.3 V/TTL (5V tolerant)
 - Active with logic low (for AUX2/SHDNn pin)
 - Emergency shutdown sources: SHDNn, PXI star trigger input, PXI trigger bus
- Watchdog timer
 - Base clock available: 10MHz, fixed
 - Counter width: 32-bit
 - Watchdog Timer Overflow sources: Onboard 32-bit watchdog timer, PXI star trigger input, PXI trigger bus

General Specifications

- I/O Connector: 62-pin D-sub male
- Operating temperature: 0 to 55°C
- Storage temperature: -20 to 70°C
- Humidity: 5 to 95% non-condensing
- Power requirements (when all relays are activated simultaneously)

+5V	+3.3V
1A	400mA

- Dimensions (not including connectors)
 - 160 mm x 100 mm

1.4 Software Support

ADLINK's ADL-SWITCH driver package is for Microsoft Windows operating systems, including Windows 98/ME/NT/2000/XP.

The driver package also provides utilities to test your switch module, as well as programming samples and source codes in Microsoft Visual Basic and Visual C/C++.

For other operating systems, please contact ADLINK for more information.

2

Installation

This chapter describes the installation process for the ADLINK switch module. Please read the contents of the package and the disassembling information carefully as they are important in the implementation of the ADLINK switch module.

2.1 Contents

The package consists of the following items in addition to the User Manual:

- PXI-7921, 24-CH Multiplexer DPDT Relay module
- This User's Guide
- ADLINK Software CD
- ADL-Switch User's Guide

If any of these items are missing or broken, please do not hesitate to contact ADLINK or the dealer from whom the product was purchased. Keep the shipping materials and carton for future storage or shipping.

2.2 Unpacking

ADLINK switch module contains sensitive electronic components that can be easily damaged by static electricity. The switch module should be operated on a grounded anti-static mat. It is strongly recommended that the operator wears an anti-static wristband, grounded at the same point as the anti-static mat.

Inspect the box for any obvious damage. Check the unit to ensure there are no shipping and handling damages that may have occurred before proceeding.

After opening, remove the system module and place it only on a grounded anti-static surface component side up.

Again, inspect the module for any damage. Press down on all the socketed IC's to make sure they are all properly seated. Please do this only on a firm and flat surface.

Note: DO NOT APPLY POWER TO THE MODULE IF IT HAS BEEN DAMAGED.

You are now ready to install the PXI-7921.

2.3 Mechanical Drawing

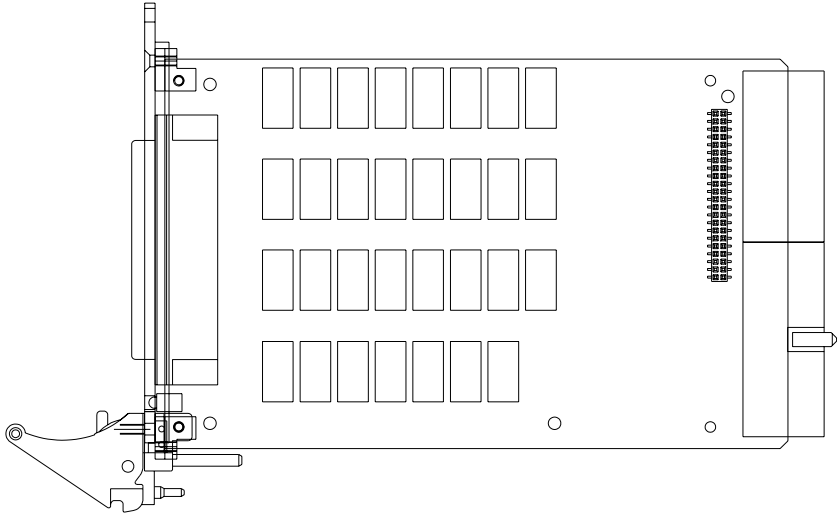

Figure 1: ADLINK Switch Module

ADLINK switch module is packaged in a Eurocard form factor compliant with PXI Specifications measuring 160 mm in length and 100 mm in height (not including connectors). A 62-pin connector is located at the front panel for wiring purposes and the J1/J2 IEC connectors in the rear are used to link the chassis backplane. With its modular, rugged, and high shock resistant mechanical features, the switch module functions exceptionally well in any harsh environment application.

2.4 Installing the switch module into a PXI Platform

To insert the ADLINK PXI switch module, align the module's edge with the card guide in the PXI chassis. Slide the switch module into the chassis, until resistance is felt from the PXI connector. Push the ejector upwards and fully

insert the switch module into the chassis. Once inserted, a “click” can be heard from the ejector latch. Tighten the screws on the front panel.

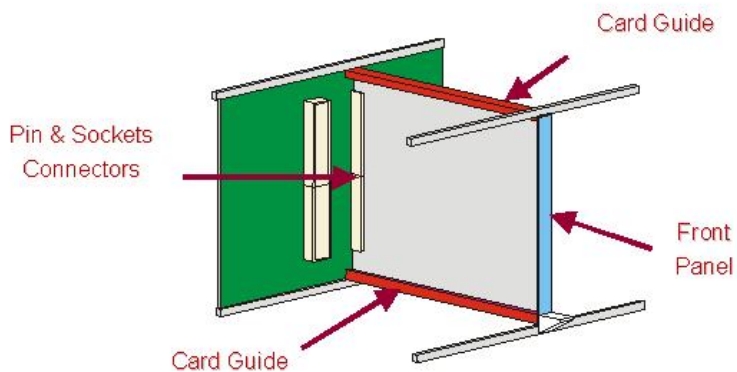

Figure 2: Installing the switch module into a PXI platform

Signal Connection

3.1 PXI-7921 Topology

The ADLINK PXI-7921 is the armature relay multiplexer module which consists of a 24x1 2-wire multiplexer. It also can operate as two groups of 12x1 2-wire multiplexer, four groups of 6x1 2-wire multiplexer, one group of 48x1 1-wire multiplexer, or one group of 12x1 4-wire multiplexer. These configurations are totally software programmable.

The PXI-7921 typically connects one instrument, such as a DMM or digitizer, to many measurement points or a signal source to several points needing excitation. Without jumper settings, complete software programming makes PXI-7921 easy-to-use and dedicated for versatile applications. PXI-7921 fully supports PXI trigger functions. Multiple switch modules can therefore be synchronized or triggered without additional field-wiring.

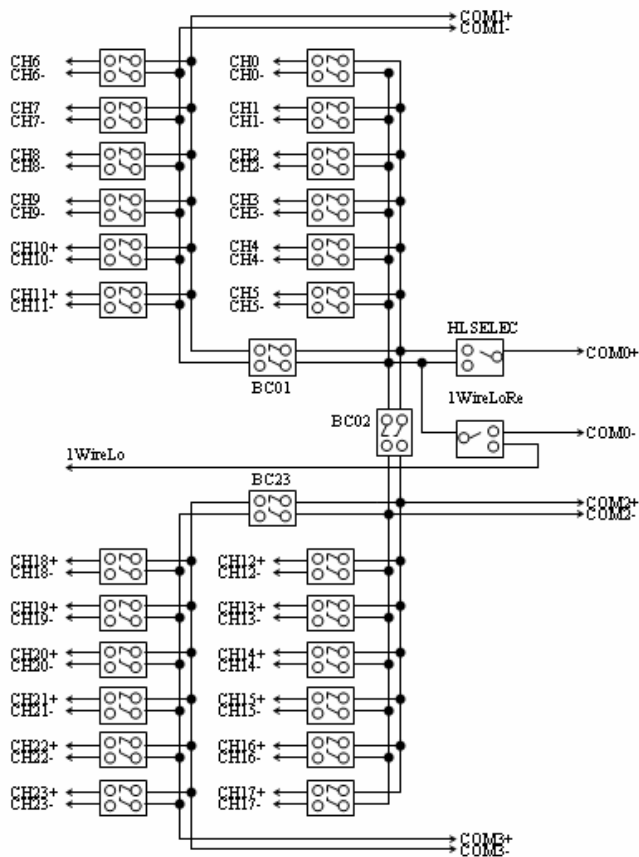

3.2 PXI-7921 Pin Assignments & Descriptions

	22. +5 V _{OUT}	
43. COM2+	23. CH8+	1. CH0+
44. COM2-	24. CH8-	2. CH0-
45. COM3+	25. CH9+	3. CH1+
46. COM3-	26. CH9-	4. CH1-
47. CH18+	27. CH10+	5. CH2+
48. CH18-	28. CH10-	6. CH2-
49. CH19+	29. CH11+	7. CH3+
50. CH19-	30. CH11-	8. CH3-
51. CH20+	31. CH12+	9. CH4+

52. CH20-	32. CH12-	10. CH4-
53. CH21+	33. CH13+	11. CH5+
54. CH21-	34. CH13-	12. CH5-
55. CH22+	35. CH14+	13. COM0+
56. CH22-	36. CH14-	14. COM0-
57. CH23+	37. CH15+	15. COM1+
58. CH23-	38. CH15-	16. COM1-
59. 1WireloRef*	39. CH16+	17. CH6+
60. TRG_IN	40. CH16-	18. CH6-
61. S_ADV	41. CH17+	19. CH7+
62. SHDNn	42. CH17-	20. CH7-
		21. GND

*not used in two-wire mode

Table 1: Pin Assignment (2 wire)

	22. +5 V _{OUT}	
43. COM2+*	23. CH8	1. CH0
44. COM2-*	24. CH32	2. CH24
45. COM3+*	25. CH9	3. CH1
46. COM3-*	26. CH33	4. CH25
47. CH18	27. CH10	5. CH2
48. CH42	28. CH34	6. CH26
49. CH19	29. CH11	7. CH3
50. CH43	30. CH35	8. CH27
51. CH20	31. CH12	9. CH4
52. CH44	32. CH36	10. CH28
53. CH21	33. CH13	11. CH5
54. CH45	34. CH37	12. CH29
55. CH22	35. CH14	13. COM0+
56. CH46	36. CH38	14. COM0-
57. CH23	37. CH15	15. COM1+*
58. CH47	38. CH39	16. COM1-*
59. 1WireloRef	39. CH16	17. CH6
60. TRG_IN	40. CH40	18. CH30
61. S_ADV	41. CH17	19. CH7
62. SHDNn	42. CH41	20. CH31
		21. GND

*not used in one-wire mode

Table 2: Pin Assignment (1 wire)

	22. +5 V _{OUT}	
43. COM2+	23. CH8A+	1. CH0A+
44. COM2-	24. CH8A-	2. CH0A-
45. COM3+	25. CH9A+	3. CH1A+

46. COM3-	26. CH9A-	4. CH1A-
47. CH6B+	27. CH10A+	5. CH2A+
48. CH6B-	28. CH10A-	6. CH2A-
49. CH7B+	29. CH11A+	7. CH3A+
50. CH7B-	30. CH11A-	8. CH3A-
51. CH8B+	31. CH0B+	9. CH4A+
52. CH8B-	32. CH0B-	10. CH4A-
53. CH9B+	33. CH1B+	11. CH5A+
54. CH9B-	34. CH1B-	12. CH5A-
55. CH10B+	35. CH2B+	13. COM0+
56. CH10B-	36. CH2B-	14. COM0-
57. CH11B+	37. CH3B+	15. COM1+
58. CH11B-	38. CH3B-	16. COM1-
59. 1WireLoRef*	39. CH4B+	17. CH6A+
60. TRG IN	40. CH4B-	18. CH6A-
61. S_ADV	41. CH5B+	19. CH7A+
62. SHDNn	42. CH5B-	20. CH7A-
		21. GND

*not used in four-wire mode

Table 3: Pin Assignment (4 wire)

Signal Name	Type	Description
COM0± (one wire) COM<0..3>± (two wire) COM<0..1>A± (four wire) COM<0..1>B± (four wire)	Input/Output	Common---The common for each bank.
CH<0..47> (one wire) CH<0..23>± (two wire) CH<0..11>A± (four wire) CH<0..11>B± (four wire)	Input/Output	Channels---Where signals are connected to the switch card. CH χ + and CH χ - are switched together.
1WireLoRef	Input/Output	1 Wire Low Reference---The common reference signal used in one-wire mode.
TRG-IN	Input	Trigger Input---Trigger from an instrument to advance the switch card to the next scan entry.
S_ADV	Output	Scanner Advanced---Trigger to an instrument that indicated the switch card has advanced to the next scan and relays are debounced.
SHDNn	Input	Emergency Shutdown---The trigger used to shutdown the system.
+5V OUT	Output	+5V VDC Source---Provide +5 power pin.
GND	Output	Ground---Provide system ground pin.

COM0± (one wire) COM<0..3>± (two wire) COM<0..1>A± (four wire) COM<0..1>B± (four wire)	Input/Output	Common---The common for each bank.
CH<0..47> (one wire) CH<0..23>± (two wire) CH<0..11>A± (four wire) CH<0..11>B± (four wire)	Input/Output	Channels---Where signals are connected to the switch card. CH χ + and CH χ - are switched together.

Table 4: Pin Description

3.3 TB-6221 Terminal Board

Users can use the TB-6221 terminal board that consists of a printed circuit with screw terminals. The terminal block connects directly to the front panel I/O connector of the PXI-7921.

The TB-6221's default printed circuit is in 2-wire mode. If other configuration is preferred, user can refer the table on TB-6221 to identify the pin connected.

2-wire MUX

This configuration has one 24x1 2-wire multiplexer Bank0, which has twenty-four channels. The following diagram illustrates the terminal board pin definition.

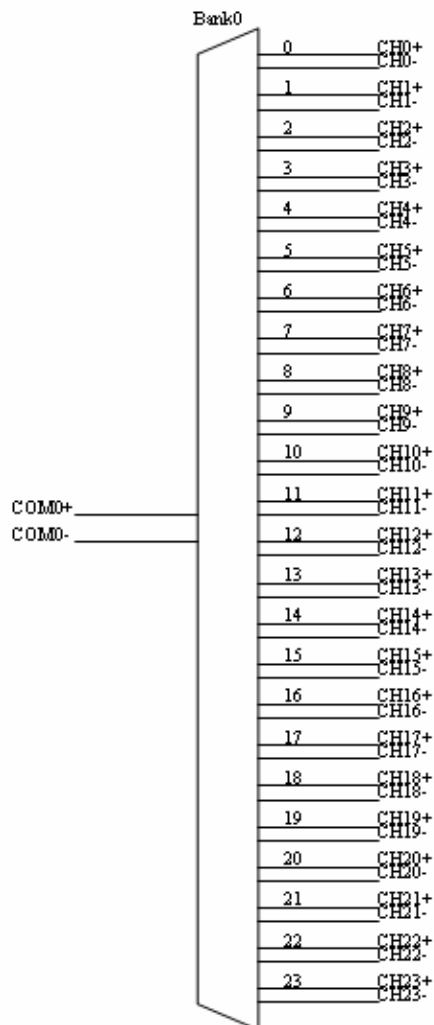

Figure 3: 24x1 MUX

2-wire, 2-group MUX

This configuration has two 12x1 2-wire multiplexers Bank0 and Bank1, each has twelve channels. The following diagram illustrates the terminal board pin definition.

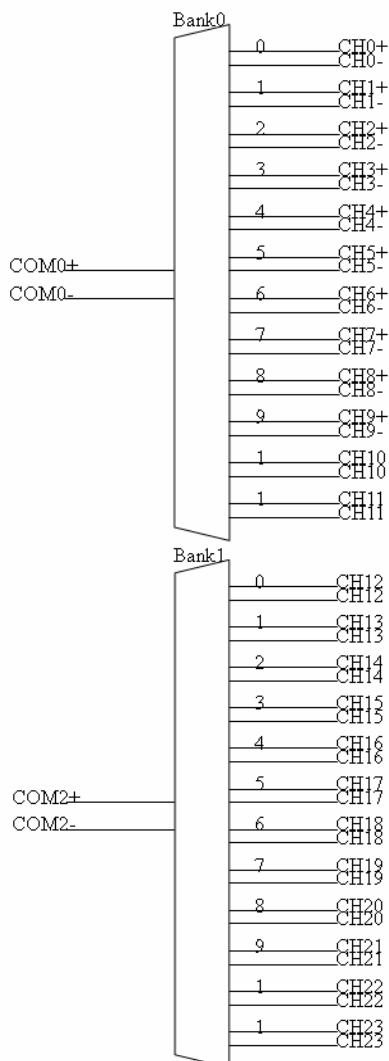

Figure 4: Two 12x1 MUX

2-wire, 4-group MUX

This configuration has four 6x1 2-wire multiplexers Bank0, Bank1, Bank2 and Bank3, each has six channels. The following diagram illustrates the terminal board pin definition.

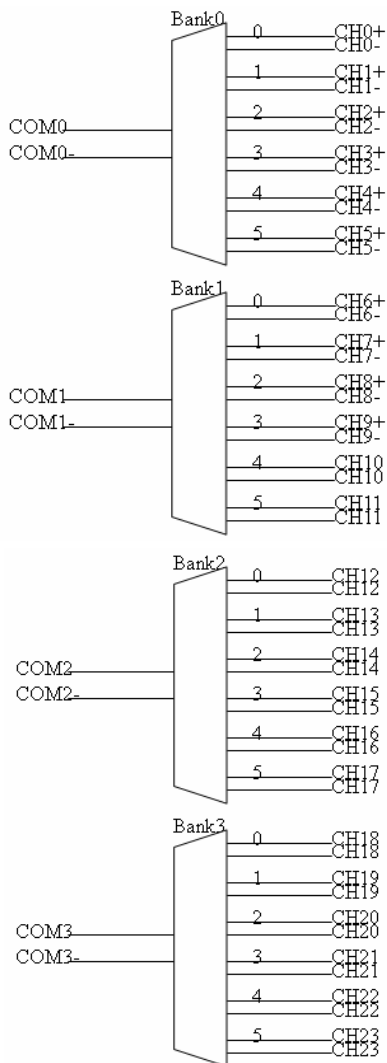

Figure 5: Four 6x1 MUX

1-wire MUX

This configuration has one 48x1 1-wire multiplexer Bank0, which has forty-eight channels. The following diagram illustrates the terminal board pin definition.

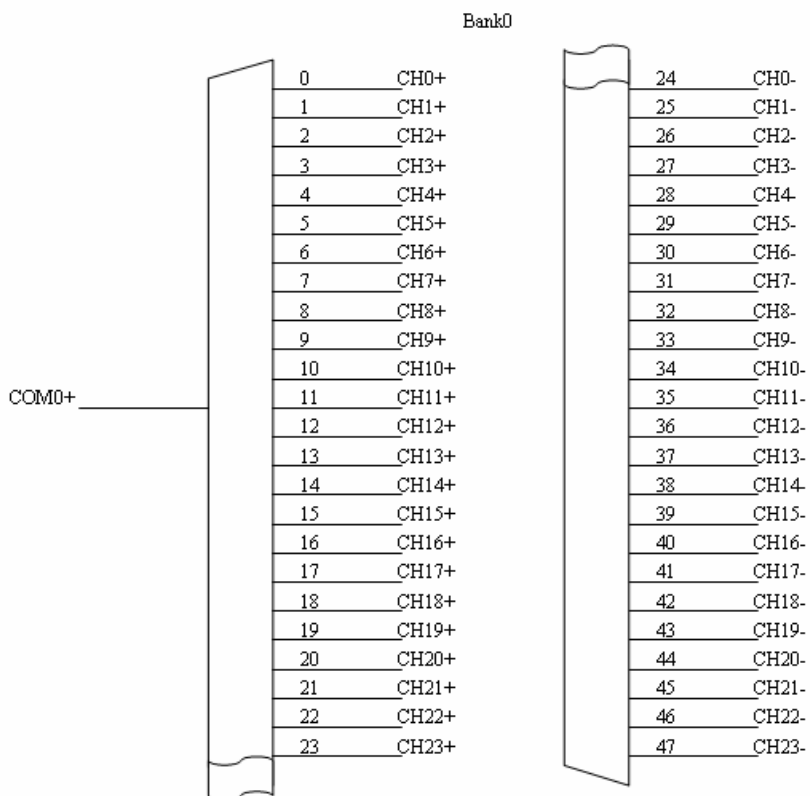

Figure 6: 48x1 MUX

4-wire MUX

This configuration has one 12x1 4-wire multiplexer Bank0, which has twelve channels. The following diagram illustrates the terminal board pin definition.

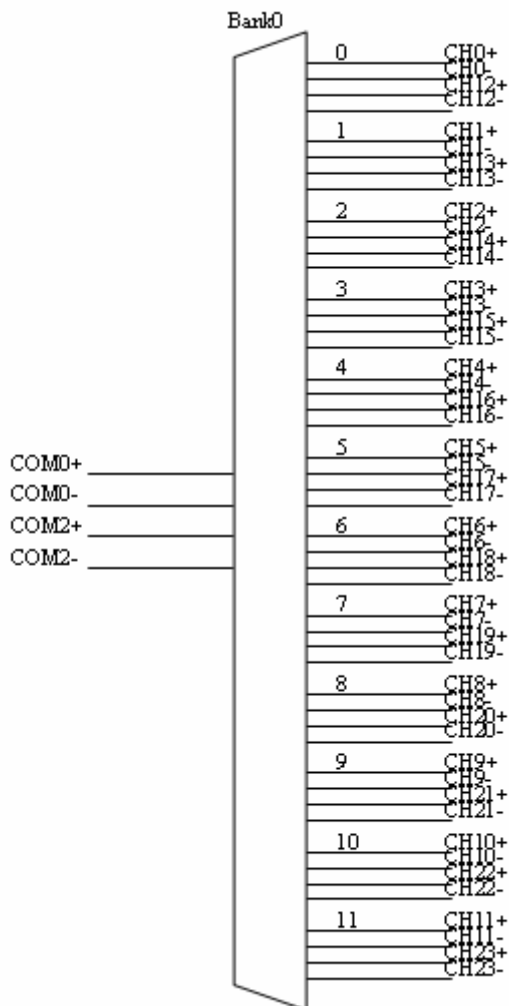

Figure 6: 4-wire MUX

Operation Theorem

4.1 Hardware Block Diagram

The ADLINK PXI Switch Module features an onboard FPGA for relay switching control, trigger control, scanlist storage and sequencing. The PXI triggering and synchronization functions, such as Star Trigger and Trigger Bus are also supported. In addition to the Trigger In and Scanner Advanced signals for external instruments handshaking, the switch module provides eight channels of programmable digital I/O interface to facilitate general purpose control applications.

To make full use of the flexible trigger and signaling system on the PXI platform, the switch module has a built-in signal routing matrix that can exchange signals between front panel digital I/O, Star Trigger, and Trigger Bus.

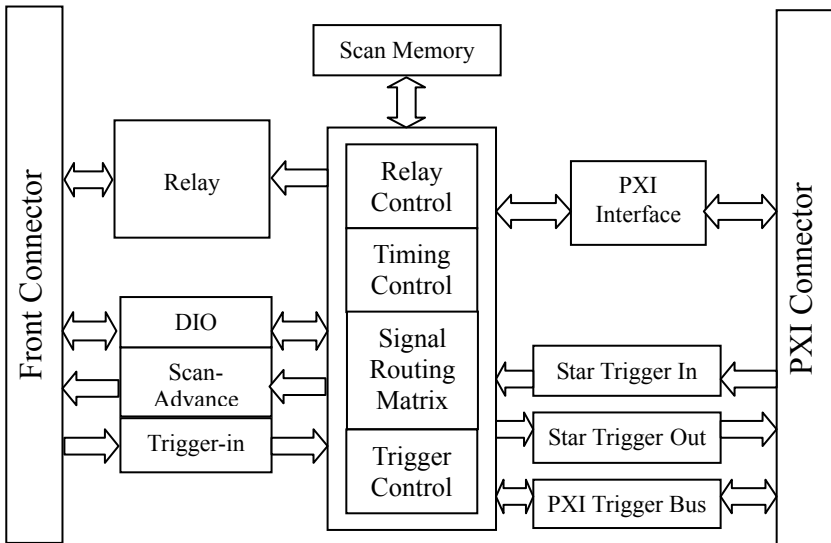

Figure 7: Hardware Block Diagram

4.2 Operation Mode

The ADLINK PXI Switch Module provides two relay operation modes to accommodate different application requirements.

Direct-update

The Switch Module updates the relay pattern immediately upon receiving a software command. This mode provides a straightforward control over switch module with minimal hardware intervention. If relay contact bouncing is of a concern, users would need to insert software delay.

ADLINK recommends the debounce time to be at least 5ms on PXI-7921.

Auto-scan

The ADLINK PXI switch module features onboard memory to store user specified scanlist of up to 1024-entry. In each scanlist entry, users can specify relay pattern, pattern advancing delay time and criterion.

The switch module can set status bit or generate local interrupt to inform user's program whether the pattern has been debounced and advanced to the next scanlist entry. Users can also specify one-time or cyclic scanning of scanlist entries.

This operating mode supports trigger signals for instrument handshaking. For more information on handshaking signals, please refer to section 4.3.

4.3 Handshaking

In the Auto-scan mode, ADLINK PXI switch module accepts Trigger In and generates Scanner Advanced signal to synchronize relay switching and measurements with PXI instruments or external measurement devices.

Trigger In

The *Trigger In* signal from PXI instruments or external measurement devices instruct the ADLINK PXI switch module to update the relay pattern according to the one specified in the scanlist entry.

Users may specify wait-for-trigger instruction in a scanlist entry, to have the switch module wait for the *Trigger In* before relay pattern is updated. The polarity of *Trigger In* can be set to either rising-edge or falling-edge active.

For more information on scanlist configuration, please refer to the software programming users' guide.

Figure 8 illustrates the available signal sources for the Trigger In signal. Signal names in the solid-line box represent the external (physical) signal on

connectors, and signals in the dotted-line box represents switch module's internal signal.

Figure 8: Available signal sources for *Trigger In*

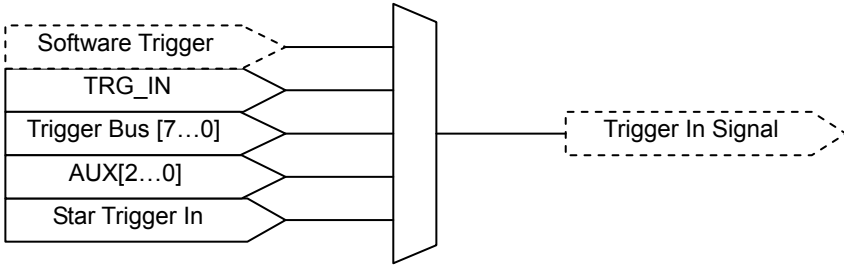

Scanner Advanced

After updating the relay pattern, the switch module starts its debounce timer and waits for the relay contacts to settle. When the debounce time elapses, the switch module will generate a *Scanner Advanced* signal to notify the PXI instruments or external measurement devices that the relay contacts have settled, and ready to take a new measurement.

The waveform, polarity and pulse width of *Scanner Advanced* signal can also be software programmed.

For more information on scanlist configuration, please refer to the software programming users' guide.

Figure 9 illustrates the available signal destinations for the *Scanner Advanced* signal. Signal names in the solid-line boxes represent the external (physical) signal on connectors, while signals in the dotted-line boxes represent switch module's internal signal.

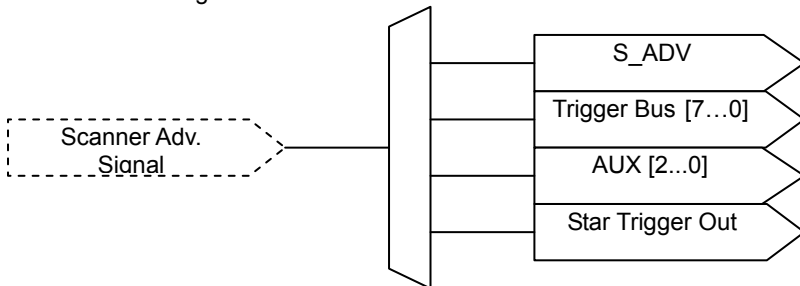

Figure 9: Available signal destinations for *Scanner Advanced*

Handshaking protocol

Figures 10 and 11 depict the relationship between *Trigger In*, *Scanner Advanced*, and relay pattern in handshaking mode. In Figure 11 the *Scanner Advanced* is set to pulsating mode.

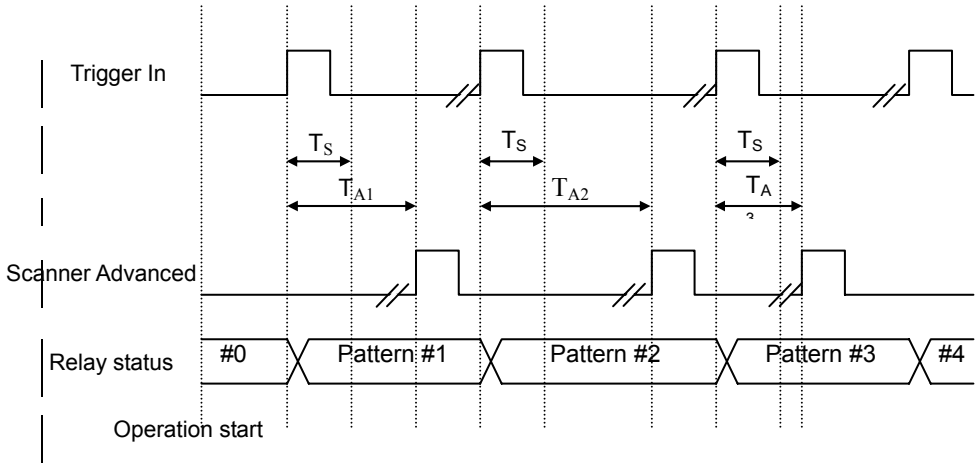

Figure 10: Handshaking operation (Scanner Advanced set in pulsating mode)

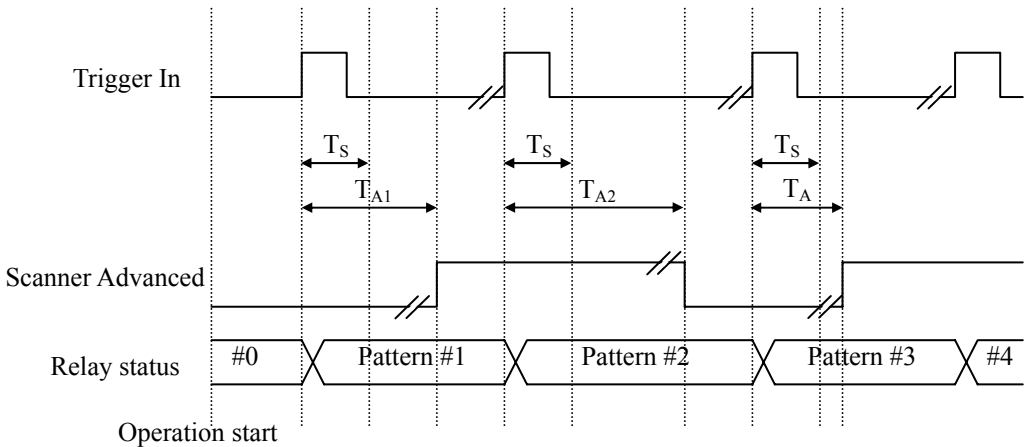

Figure 11: Handshaking operation (Scanner Advanced set in toggling mode)

Once the operation starts and has received a *Trigger In* signal, the switch module updates the relay pattern to that specified in the first entry of scanlist.

T_S is the default debounce time for a switch module, i.e. 5ms for PXI-7921. T_{An} is the user specified scan delay time in the scanlist entry, indicating the time between the relay being debounced and the exact moment that a measurement device takes a new measurement. The actual delay time would be the greater of the two times, to guarantee that measurement devices take measurements after the signal path is fully settled, and the relays switch as close as possible to their maximum operating speed.

As the scan delay time elapses, the switch module generates *Scanner Advanced* signal to inform the measurement device to take a new measurement.

After the measurement completes, the measurement device will generate another *Trigger In* signal to have the switch module update the relay pattern to that specified in the second entry of scanlist.

The handshaking process will continue, until it reaches the end of the scanlist (if one-time scanning mode is selected), or when a software scan-abort command is received.

Connecting, Trigger and Synchronize with External DMM

In this example, Agilent® 33401A 6-1/2 Digital Multimeter (DMM) is used to demonstrate signal connection for handshaking operation.

The DMM provides two terminals on the rear panel for the handshaking operation process, *Trig In* and *VM Comp*. The *Trig In* connects to the *Scanner Advanced* output on switch module, while the *VM Comp* to *Trigger In*. If the terminal board is used, wire *Trig In* to *TRG_IN* on terminal board, and the *VM Comp* to *S_ADV*.

Follow the instructions below to ensure the handshake functions properly:

1. Configure ADLINK PXI switch module's *Trigger In* to rising-edge triggered, *Scanner Advanced* output in active-low pulsating mode with pulse width of at least 2 μ s.
2. Configure the DMM to wait for external *Trig In* before a measurement, and generate *VM Comp* after a measurement. Arm the DMM to wait for the first trigger.
3. Setup the scanlist and auto-scan mode. The first entry in the scanlist should be set disable wait for the *Trigger In*, but enable *Scanner Advanced* output. Succeeding entries should enable both *Trigger In* and *Scanner Advanced* output. Download the scanlist to the switch module afterward.
4. Start auto-scan by sending scan start command to the switch

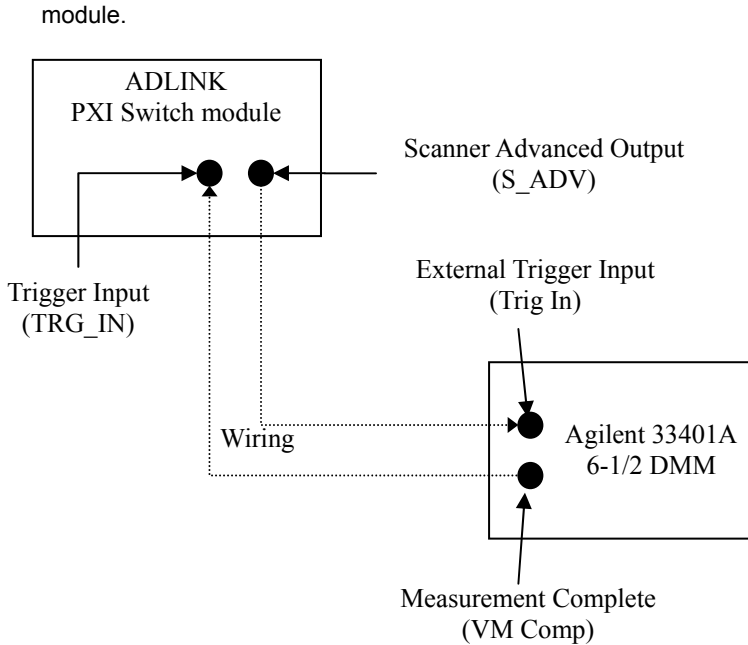

Figure 12: Signal Connection between Switch Module and Agilent DMM

For more information on scanlist configuration, scan mode setup, start, and stop functions of the auto-scanning process, please refer to the software programming users' guide.

4.4 Trigger Bus

PXI specification defines eight bused-lines across slots in a segment. Users can route various trigger signal to synchronize multiple PXI instruments, and/or simplify field wiring across multiple ADLINK Switch Modules.

On ADLINK Switch Modules, the trigger bus driver is disconnected from PXI trigger bus before users' configuration.

Figure 13 illustrates the available signal destinations for Trigger Bus[7..0]. Signal names in the solid-line boxes represent the external (physical) signals on connectors while signals in the dotted-line boxes represent the switch module's internal signal.

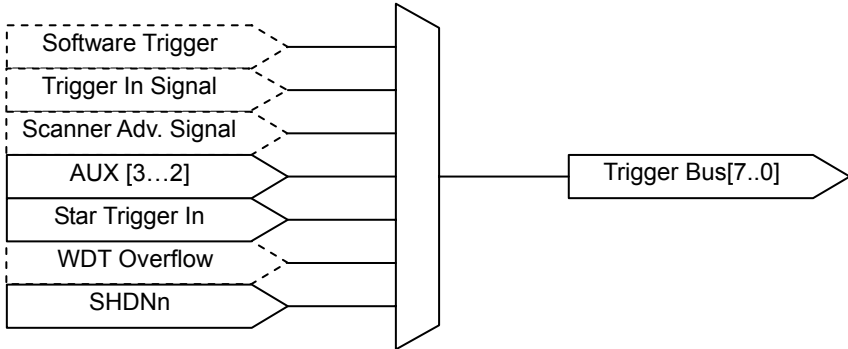

Figure 13: Available signal sources for Trigger Bus[7..0]

4.5 Star Trigger

The PXI specification defined 13 matched trigger lines to connect to the first 13 PXI peripheral slots on a PXI backplane. Users can route various trigger signal to synchronize multiple PXI instruments and achieve tight timing control.

On ADLINK Switch Modules, the star trigger driver is disconnected from the PXI backplane before users' configuration. The maximum skew between each star trigger line is controlled to within 1ns.

Note the reverse input voltage protection range is -0.5V to +5.5V. When the local bus is used on peripheral modules, make sure that the voltage level is compatible with ADLINK Switch Module.

Figure 10 illustrates the available signal destinations for Star Trigger. Signal names in the solid-line boxes represent the external (physical) signal on connectors, while signals in the dotted-line boxes represent the switch module's internal signal.

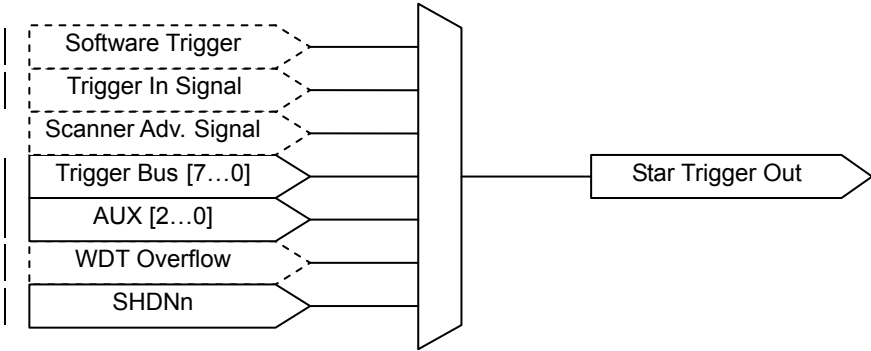

Figure 10: Available signal sources for Star Trigger

4.6 Auxiliary Digital I/O

The eight auxiliary digital I/O lines on ADLINK Switch Modules provide versatility to users' control applications. Each digital I/O line can be input, output or tri-stated. When in output mode, users can still read back the actual logic-level on the I/O line. All digital lines are pulled-up to 5V with 10k ohm input resistance.

Note that AUX[2..0] are dual function pins, driving these pins while enabling handshaking or emergency shutdown functions, may falsely trigger the Switch Module or external instruments.

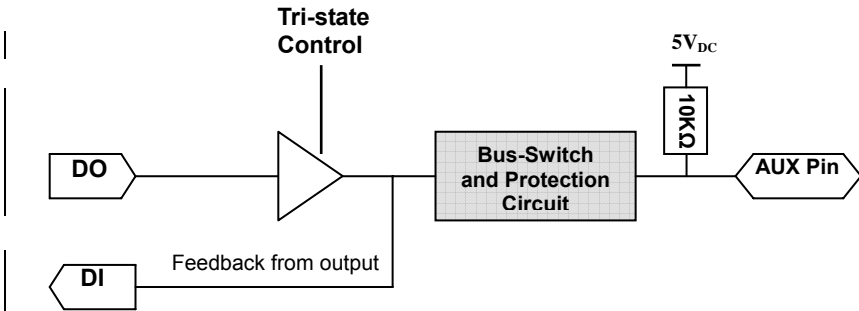

Figure 11: Auxiliary Digital I/O Function Block

4.7 Hot-Swap

The Switch Module can be hot-swapped during hardware failure in non-interruptible or high-availability systems where system shutdown is not an option.

PXI-7921 incorporates an onboard hot-swap control mechanism. However the extent of the hot-swap functionality support depends on the operating system and the PXI platform.

Microsoft Embedded XP[®] supports the native hot-swap function. The operating system automatically releases system resources when a switch module is extracted and recognizes the new device.

To remove a switch module, first release the screws on the front panel then push down the red latch on the ejector. When the blue LED turns on, the Switch module is ready to be removed by fully pushing down the ejector.

To insert another switch module, align the module's edge with the card guide in the PXI chassis. Slide the switch module into the chassis, until there is resistance from the PXI connector. Push the ejector up and fully insert the switch module into the chassis, a click should be heard from the ejector latch. The blue LED on the front panel of the switch module will switch off when it is ready for operation. Tighten the screws on the front panel.

Note: Microsoft Windows 2000[®] does not natively support hot-swap however, PXI-7921 can be hot-swapped by manual control via an additional hot-swap driver. For the hot-swap driver on Windows 2000 and other operating systems such as Linux, VxWorks, etc., please contact ADLINK for more information.

4.8 Emergency Shutdown

In safety-critical applications, users can enable the emergency shutdown function on PXI Switch Module, to manually set the relay pattern to preset state.

To access this function, users must first configure the emergency shutdown function by windows API. Generally the trigger source is on the front panel and connected to a push button, which pulls the SHDNn pin to logic-low when activated. When multiple PXI Switch modules are installed in a PXI chassis, the trigger source can be routed through the PXI Trigger Bus and eliminate field wiring across multiple devices. Figure 12 illustrates available trigger sources for emergency shutdown. Signal names in the solid-line boxes represent the external (physical) signal on connectors and signals in the dotted-line boxes represent the switch module's internal signal.

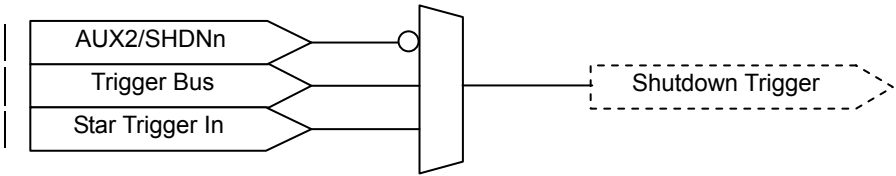

Figure 12: Available trigger sources for emergency shutdown

The default relay pattern for emergency shutdown is All-Off on PXI-7921; users can change the pattern by Windows API.

Upon receiving the emergency shutdown trigger, the Switch Module enters shutdown mode, and the relay pattern is switched to the preset state. If the Switch Module is in *Auto-scan* mode, the updating process would be stopped immediately; in *Direct Update* mode where the switch module will not accept any further update instructions.

To leave emergency shutdown mode, users must call `adlSwitch_Recovery` in Windows API. The relay pattern would stay the same as they would in the emergency shutdown mode, and the scanlist (if set) being rewound to the first entry.

Note the auxiliary digital I/O function pin AUX2 shares the SHDNn pin; driving AUX2 to logic-low while the emergency shutdown function is enabled. It will falsely trigger the Switch Module to enter shutdown mode.

This function is disabled by default. For more information, please refer to the software programming users' guide.

4.9 Watchdog Timer

In safety-critical applications, users can enable the watchdog timer function on PXI Switch Module to automatically set the relay pattern to preset state, in case the operating system or PXI controller crashes.

To access this function, users must first configure the watchdog timer overflow trigger source by windows API. Generally the trigger source would come from the onboard 32-bit watchdog timer. When multiple ADLINK PXI Switch modules are installed in a PXI chassis, the trigger source can be routed through the PXI Trigger Bus and eliminate redundant watchdog timer setting on multiple devices.

Figure 13 illustrates the available trigger sources for watchdog timer overflow. Signal names in the solid-line boxes represent the external (physical) signal on connectors and signals in the dotted-line boxes represent the switch module's internal signal.

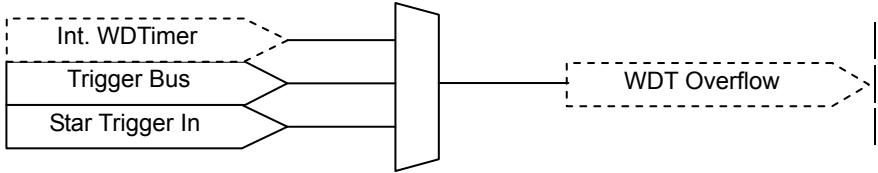

Figure 13:..Available trigger sources for watchdog timer overflow

The watchdog timer overflow interval can be programmed through Windows API. After enabling the watchdog timer, users must periodically reset the timer by software command. If the timer is not being reset within the specified interval, the switch module will generate an overflow signal and set the relay pattern to the one specified by users.

This function is disabled by default. For more information, please refer to the software programming users' guide.

Warranty Policy

Thank you for choosing ADLINK. To understand your rights and enjoy all the after-sales services we offer, please read the following carefully:

1. Before using ADLINK's products please read the user manual and follow the instructions exactly.
2. When sending in damaged products for repair, please attach an RMA application form.
3. All ADLINK products come with a two-year guarantee, repaired free of charge.
 - The warranty period starts from the product's shipment date from ADLINK's factory.
 - Peripherals and third-party products not manufactured by ADLINK will be covered by the original manufacturers' warranty.
 - End users requiring maintenance services should contact their local dealers. Local warranty conditions will depend on local dealers.
4. This warranty will not cover repair costs due to:
 - a. Damage caused by not following instructions.
 - b. Damage caused by carelessness on the users' part during product transportation.
 - c. Damage caused by fire, earthquakes, floods, lightening, pollution, other acts of God, and/or incorrect usage of voltage transformers.
 - d. Damage caused by unsuitable storage environments (i.e. high temperatures, high humidity, or volatile chemicals).
 - e. Damage caused by leakage of battery fluid.
 - f. Damage from improper repair by unauthorized technicians.
 - g. Products with altered and/or damaged serial numbers.
 - h. Other categories not protected under our guarantees.
5. Customers are responsible for shipping costs to transport damaged products to our company or sales office.
6. To ensure the speed and quality of product repair, please download a RMA application form from our company website: <http://rma.adlinktech.com/policy>. Damaged products with attached RMA forms receive priority.

For further questions, please contact our FAE staff.

ADLINK: service@adlinktech.com