



**ADLINK**  
TECHNOLOGY INC.

# **PCle-8154**

4-Axis Servo/Stepper  
Motion Control Card

## **User's Manual**

**Manual Rev.:** 2.00

**Revision Date:** Oct. 7, 2015

**Part No:** 50-11258-1000

**Advance Technologies; Automate the World.**

# Revision History

Revision	Release Date	Description of Change(s)
2.00	Oct. 7, 2015	Initial Release

# Preface

## **Copyright 2015 ADLINK Technology, Inc.**

This document contains proprietary information protected by copyright. All rights are reserved. No part of this manual may be reproduced by any mechanical, electronic, or other means in any form without prior written permission of the manufacturer.

## **Disclaimer**

The information in this document is subject to change without prior notice in order to improve reliability, design, and function and does not represent a commitment on the part of the manufacturer.

In no event will the manufacturer be liable for direct, indirect, special, incidental, or consequential damages arising out of the use or inability to use the product or documentation, even if advised of the possibility of such damages.

## **Environmental Responsibility**

ADLINK is committed to fulfill its social responsibility to global environmental preservation through compliance with the European Union's Restriction of Hazardous Substances (RoHS) directive and Waste Electrical and Electronic Equipment (WEEE) directive. Environmental protection is a top priority for ADLINK. We have enforced measures to ensure that our products, manufacturing processes, components, and raw materials have as little impact on the environment as possible. When products are at their end of life, our customers are encouraged to dispose of them in accordance with the product disposal and/or recovery programs prescribed by their nation or company.

## **Trademarks**

Product names mentioned herein are used for identification purposes only and may be trademarks and/or registered trademarks of their respective companies.

## Conventions

Take note of the following conventions used throughout this manual to make sure that users perform certain tasks and instructions properly.



NOTE:

Additional information, aids, and tips that help users perform tasks.

---



Information to prevent **minor** physical injury, component damage, data loss, and/or program corruption when trying to complete a task.

---



Information to prevent **serious** physical injury, component damage, data loss, and/or program corruption when trying to complete a specific task.

---

# Table of Contents

<b>Preface</b> .....	<b>iii</b>
<b>List of Tables</b> .....	<b>ix</b>
<b>List of Figures</b> .....	<b>xi</b>
<b>1 Introduction</b> .....	<b>1</b>
1.1 Features .....	3
1.2 Specifications .....	4
1.3 Supported Software .....	5
Programming Library .....	6
MotionCreatorPro .....	6
1.4 Available Terminal Board .....	6
1.5 PCB Layout .....	7
1.6 CN2 Pin Assignments: Main Connector .....	7
1.7 K1/K2 Pin Assignments: Simultaneous Start/Stop .....	10
1.8 P1 Manual Pulse Generator .....	10
1.9 CN5 Pin Assignments: TTL I/O .....	11
<b>2 Getting Started</b> .....	<b>13</b>
2.1 Package Contents .....	13
2.2 PCIe-8154 Hardware Installation .....	13
Hardware Configuration .....	13
PCIe Slot Selection .....	13
Installation Procedures .....	14
Troubleshooting: .....	14
2.3 Software Driver Installation .....	14
2.4 JP2 to JP8 Jumper Setting for Pulse Output .....	15
2.5 SW1 Card Index Selection .....	15
2.6 Signal Connections .....	16
2.6.1 Pulse Output Signals OUT and DIR on CN2 .....	16

2.6.2	Encoder Feedback Signals EA, EB and EZ.....	18
2.6.3	Origin Signal ORG .....	21
2.6.4	End-Limit Signals PEL and MEL.....	22
2.6.5	In-Position Signal INP .....	23
2.6.6	Alarm Signal ALM .....	24
2.6.7	Deviation Counter Clear Signal ERC.....	25
2.6.8	General-purpose Signal SVON.....	26
2.6.9	General-purpose Signal RDY .....	27
2.6.10	Multi-Functional Output Pin: DO/CMP .....	28
2.6.11	Multi-Functional Input Pin: DI/LTC/SD/PCS/CLR/EMG.....	29
2.6.12	Manual Pulse Generator Input Signals PA and PB ..	30
2.6.13	Simultaneous Start/Stop Signals STA and STP .....	31
2.6.14	General Purpose TTL I/O EDI And EDO .....	33
<b>A Appendix: MotionCreatorPro.....</b>		<b>35</b>
A.1	About MotionCreatorPro .....	35
A.2	Initiating MotionCreatorPro .....	35
A.3	MotionCreatorPro Introduction.....	36
	Main Menu .....	36
	Select Menu .....	37
	Card Information Menu .....	38
	Configuration Menu .....	39
	Single Axis Operation Menu .....	43
	Two-Axis and Four-Axis Operation Menu .....	51
	2D_Motion Menu .....	56
	Help Menu .....	61
<b>B Appendix: Function Library Reference.....</b>		<b>63</b>
B.1	Data Types.....	63
	Function Naming .....	63
B.2	List of Functions.....	64

B.3	System and Initialization .....	68
B.4	Pulse Input/Output Configuration.....	72
B.5	Velocity mode motion .....	74
B.6	Single Axis Position Mode .....	77
B.7	Linear Interpolated Motion .....	81
B.8	Circular Interpolation Motion .....	89
B.9	Helical Interpolation Motion .....	95
B.10	Home Return Mode .....	99
B.11	Manual Pulse Generator Motion .....	102
B.12	Motion Status .....	105
B.13	Motion Interface I/O .....	106
B.14	Interrupt Control.....	114
B.15	Position Control and Counters .....	117
B.16	Position Compare and Latch .....	123
B.17	Continuous motion .....	127
B.18	Multiple Axes Simultaneous Operation .....	129
B.19	General-Purpose DIO .....	132
B.20	Soft Limit.....	134
B.21	Backlash Compensation / Vibration Suppression .....	136
B.22	Speed Profile Calculation .....	138
B.23	Extended General Purpose TTL Input/Output .....	141
B.24	Return Code .....	143
<b>C</b>	<b>Appendix: Connection Example .....</b>	<b>145</b>
C.1	General Description of Wiring.....	145
C.2	Terminal Board User Guide .....	145
	<b>Important Safety Instructions .....</b>	<b>147</b>
	<b>Getting Service.....</b>	<b>149</b>

This page intentionally left blank.



## List of Tables

Table 1-1: P1 Manual Pulse Generator .....	11
Table 2-1: SW1 Card Index .....	16
Table 2-2: Pulse Output Signals on CN3 .....	17
Table 2-3: OUT or DIR Output by Jumper .....	17
Table 2-4: EA, EB, and EZ Pin Assignments .....	19
Table 2-5: Device/Encoder/Power Connection .....	20
Table 2-6: ORG0-ORG3 Pin Assignments .....	21
Table 2-7: End-Limit Signal Pin Assignment .....	22
Table 2-8: INP Signal Connection .....	23
Table 2-9: Alarm Signal Connection .....	24
Table 2-10: ERC Connection .....	25
Table 2-11: SVON Connection .....	26
Table 2-12: RDY Signal Connection .....	27
Table 2-13: DO/CMP Connection .....	28
Table 2-14: DI/LTC/SD/PCS/CLR/EMG Connection .....	29
Table 2-15: Manual Pulse Generator Input Signal Connection .	30

This page intentionally left blank.

# List of Figures

Figure 1-1:	PCIe-8154 Block Diagram .....	2
Figure 1-2:	PCB Layout .....	7
Figure 1-3:	IDE 44-pin Connector Assignment .....	12
Figure 1-4:	DSUB 37-pin Connector Assignment .....	12
Figure 2-1:	Jumper Settings.....	15
Figure 2-2:	OUT and DIR Axis Signals .....	17
Figure 2-3:	OUT/DIR through J2/J3 Connection.....	18
Figure 2-4:	EA, EB, and EZ Input Circuits .....	19
Figure 2-5:	Line Driver Connection Output Circuit.....	20
Figure 2-6:	Device/Encoder Connection Circuit.....	21
Figure 2-7:	ORG Input Circuit .....	22
Figure 2-8:	End-Limit Signals Circuit .....	23
Figure 2-9:	INP Signal Circuit .....	24
Figure 2-10:	Input Alarm Circuit.....	25
Figure 2-11:	ERC Circuit.....	26
Figure 2-12:	SVON Circuit .....	27
Figure 2-13:	RDY Circuit.....	28
Figure 2-14:	DO/CMP Circuit.....	29
Figure 2-15:	DI/LTC/SD/PCS/CLR/EMG Circuit .....	30
Figure 2-16:	Manual Pulse Generator Input Signal Circuit .....	31
Figure 2-17:	STA & STP Connection .....	32
Figure 2-18:	STA & STP Connection With External Start/Stop.....	32
Figure 2-19:	EDI And EDO Circuit .....	33

This page intentionally left blank.

# 1 Introduction

The PCle-8154 is an advanced & modularized 4-axis motion controller card with a PCIe interface. It can generate high frequency pulses (6.55MHz) to drive stepper or servomotors. As a motion controller, it can provide 4-axis linear and circular interpolation and continuous interpolation for continuous velocity. Also, changing position/speed on the fly is available with a single axis operation.

Multiple PCle-8154 cards can be used in one system. Incremental encoder interfaces on all eight axes provide the ability to correct positioning errors generated by inaccurate mechanical transmissions.

The PCle-8154 is a completely new design. This carrier board has 4-axis pulse train output control channels. For additional functions, such as high-speed triggering or distributed I/O control, you can add on a daughter board based on requirement. This board has position compare function. Like the line scan application, the application needs motion controller to generate high speed triggering pulse and gain the high resolution images. In this situation, you can adopt a DB-8150 to extend the function on PCle-8154. In addition to motion control, sensors and actuators are key elements in machine automation. There typically needs to I/O to integrate the sensors and actuators in the controller. ADLINK also provides you another way to connect these devices: distributed I/O. Using daughter board, distributed I/O can be achieved with PCle-8154. This cost-effective configuration can reduce wiring effort and physical controller size.

Figure 1-1 shows the functional block diagram of the PCle-8154 card. The motion control functions include trapezoidal and S-curve acceleration/deceleration, linear and circular interpolation between two axes and continuous motion positioning, and 13 home return modes. All these functions and complex computations are performed internally by the ASIC, thus it can save CPU loading.

The PCle-8154 also offers three user-friendly functions.

1. Card Index Setting:

The card index value of the PCIe-8154 can be set with a DIP switch to a value between 0 and 15. This is useful for machine makers if the whole control system is very huge.

## 2. Emergency Input

An emergency input pin can be wired to an emergency button to stop sending pulse output once activated.

## 3. Software's Security Protection

To secure applications, a 16-bit value can be set in the EEPROM to prevent copying of custom programs.

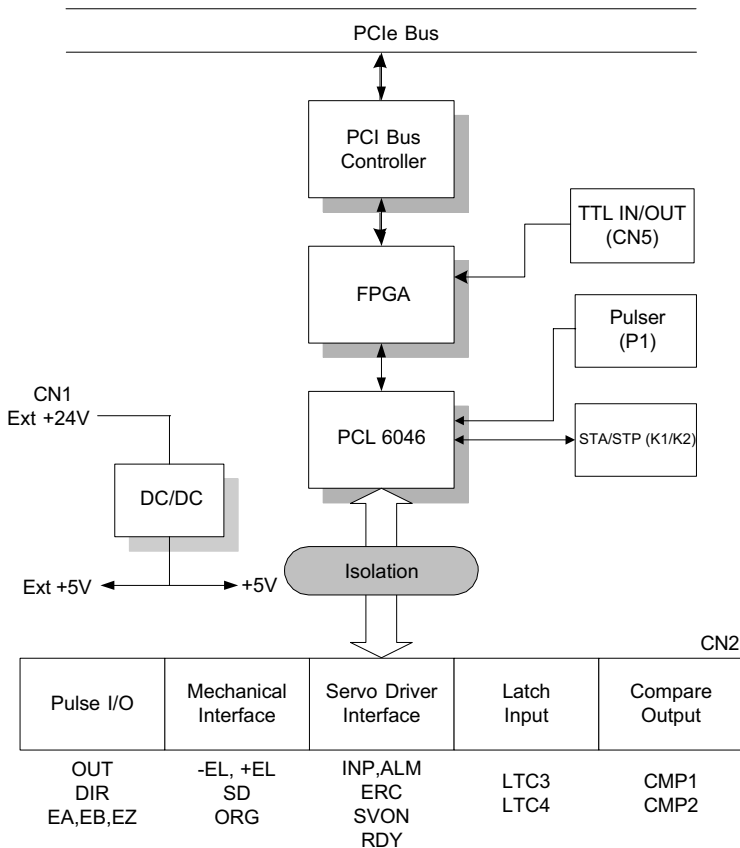

**Figure 1-1: PCIe-8154 Block Diagram**

*MotionCreatorPro* is a Windows-based application development software package included with the PCIe-8154. *MotionCreatorPro* is useful for debugging a motion control system during the design phase of a project. An on-screen display lists all installed axes information and I/O signal status of the PCIe-8154.

Windows programming libraries are also provided for C++ compilers and Visual Basic. Sample programs are provided to illustrate the operations of the functions.

## 1.1 Features

The following list summarizes the main features of the PCIe-8154 motion control system.

- ▶ PCIe bus Plug-and-Play (Universal)
- ▶ 4 axes of step and direction pulse output for controlling stepping or servomotor
- ▶ Maximum output frequency of 6.55MPPS
- ▶ Pulse output options: OUT/DIR, CW/CCW, AB phase
- ▶ Pulse input options: CW/CCW, AB phase x1, x2, x4
- ▶ Maximum pulse input frequency of 3.2Mhz in CW/CCW or AB phase X1 mode (AB phase x4 can reach 6.5Mhz).
- ▶ Programmable acceleration and deceleration time for all modes
- ▶ Trapezoidal and S-curve velocity profiles for all modes
- ▶ 2 to 4 axes linear interpolation
- ▶ 2 axes circular interpolation
- ▶ Continuous interpolation for contour following motion
- ▶ Change position and speed on the fly
- ▶ 13 home return modes with auto searching
- ▶ Hardware backlash compensator and vibration suppression
- ▶ 2 software end-limits for each axis
- ▶ 28-bit up/down counter for incremental encoder feedback
- ▶ Home switch, index signal (EZ), positive, and negative end limit switches interface on all axes
- ▶ 4-axis high speed position latch input

- ▶ 4-axis position compare and trigger output
- ▶ All digital input and output signals are 2500V<sub>rms</sub> isolated
- ▶ Programmable interrupt sources
- ▶ Simultaneous start/stop motion on multiple axes
- ▶ Manual manual pulse generator input interface
- ▶ Card index selection
- ▶ Security protection on EERPOM
- ▶ Dedicated emergency input pin for wiring
- ▶ Software supports a maximum of up to 12 PCIe-8154 cards operation in one system
- ▶ Compact PCB design
- ▶ Includes MotionCreatorPro, a Microsoft Windows-based application development software
- ▶ PCIe-8154 libraries and utilities for Windows XP/7/8.1

## 1.2 Specifications

### Applicable Motors:

- ▶ Stepping motors
- ▶ AC or DC servomotors with pulse train input servo drivers

### Performance:

- ▶ Number of controllable axes: 4
- ▶ Maximum pulse output frequency: 6.55MPPS, linear, trapezoidal, or S-Curve velocity profile drive
- ▶ Internal reference clock: 19.66MHz
- ▶ 28-bit up/down counter range: 0-268, 435, 455 or -134, 217, 728 to +134, 217, 727
- ▶ Position pulse setting range (28-bit): -134, 217, 728 to +134, 217, 728
- ▶ Pulse rate setting range (Pulse Ratio = 1: 65535):
  - ▷ 0.1 PPS to 6553.5 PPS. (Multiplier = 0.1)
  - ▷ 1 PPS to 65535 PPS. (Multiplier = 1)
  - ▷ 100 PPS to 6553500 PPS. (Multiplier = 100)



**I/O Signals:**

- ▶ Input/Output signals for each axis
- ▶ All I/O signal are optically isolated with 2500Vrms isolation voltage
- ▶ Command pulse output pins: OUT and DIR
- ▶ Incremental encoder signals input pins: EA and EB
- ▶ Encoder index signal input pin: EZ
- ▶ Mechanical limit/home signal input pins:  $\pm$ EL, ORG
- ▶ Composite pins: DI / LTC (Latch) / SD (Slow-down) / PCS (Position Change Signal) / CLR (Clear) / EMG (Emergency Input)
- ▶ Servomotor interface I/O pins: INP, ALM, and ERC
- ▶ General-purposed digital output pin: SVON, DO
- ▶ General-purposed digital input pin: RDY, GDI
- ▶ Pulse signal input pin: PA and PB (with Isolation)
- ▶ Simultaneous Start/Stop signal: STA and STP
- ▶ 16 TTL level DO and 16TTL level DI

**General Specifications**

- ▶ Connectors: 100-pin SCSI-type connector
- ▶ Operating Temperature: 0°C - 50°C
- ▶ Storage Temperature: -20°C - 80°C
- ▶ Humidity: 5 - 85%, non-condensing

**Power Consumption**

- ▶ Slot power supply (input): +5V DC  $\pm$ 5%, 900mA max
- ▶ External power supply (input): +24V DC  $\pm$ 5%, 500mA max
- ▶ External power supply (output): +5V DC  $\pm$ 5%, 300mA, max

**PCIe-8154 Dimensions (PCB size):**

- ▶ 185 (L) X 98.4 (H) mm

**1.3 Supported Software**

## Programming Library

Windows XP/7/8.1 DLLs are provided for the PCIe-8154. These function libraries are shipped with the board.

### MotionCreatorPro

The pre-loaded Windows-based utility sets up cards, motors, and systems, and can aid in debugging hardware and software problems. Users can set I/O logic parameters to be loaded in their own program.

For more information, please see “MotionCreatorPro” on page 35.

## 1.4 Available Terminal Board

ADLINK provides steppers with the DIN-100S pin-to-pin terminal board. For servo users, the DIN-814M, DIN-814M-J3A, DIN-814Y and DIN-814P-A4 are provided, with suitable servos as follows:

Mitsubishi J2 Super	DIN-814M
Mitsubishi J3A	DIN-814M-J3A
Yaskawa Sigma II	DIN-814Y
Panasonic MINAS A4	DIN-814P-A4

## 1.5 PCB Layout



NOTE:

All dimensions shown are in millimeters (mm) unless otherwise stated.

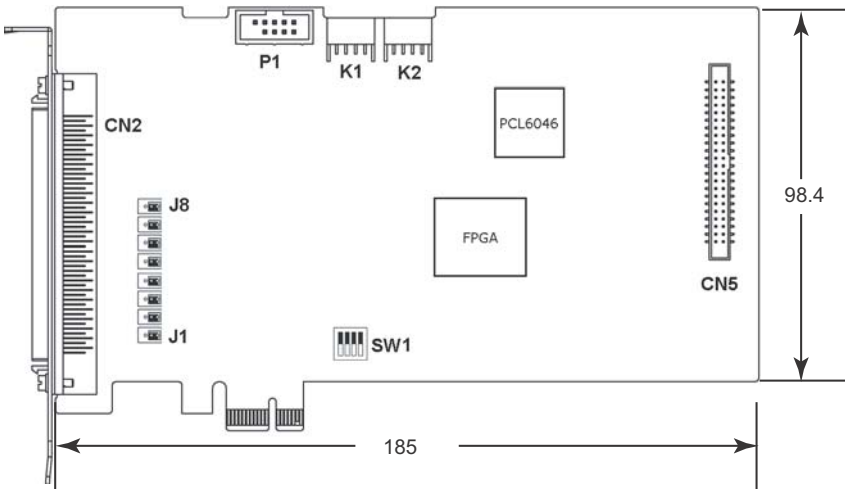

**Figure 1-2: PCB Layout**

- ▶ CN2: Input / Output Signal Connector (100-pin)
- ▶ K1 / K2: Simultaneous Start / Stop Connector
- ▶ P1: Manual Pulse generator
- ▶ SW1: DIP switch for card index selection (0-15)
- ▶ J1-J8: Pulse output selection jumper (Line Driver / Open Collector)
- ▶ CN5: TTL I/O Connector

## 1.6 CN2 Pin Assignments: Main Connector

CN2 is the main connector for motion control I/O signals.

#	Name	I/O	Function	#	Name	I/O	Function
1	VDD	O	+5V power supply output	51	VDD	O	+5V power supply output
2	EXGND	-	Ext. power ground	52	EXGND	-	Ext. power ground
3	OUT0+	O	Pulse signal (+)	53	OUT2+	O	Pulse signal (+)
4	OUT0-	O	Pulse signal (-)	54	OUT2-	O	Pulse signal (-)
5	DIR0+	O	Dir. signal (+)	55	DIR2+	O	Dir. signal (+)
6	DIR0-	O	Dir. signal (-)	56	DIR2-	O	Dir. signal (-)
7	SVON0	O	Servo On/Off	57	SVON2	O	Servo On/Off
8	ERC0	O	Dev. ctr. clr. Signal	58	ERC2	O	Dev. ctr. clr. signal
9	ALM0	I	Alarm signal	59	ALM2	I	Alarm signal
10	INP0	I	In-position signal	60	INP2	I	In-position signal
11	RDY0	I	Multi-purpose Input signal	61	RDY2	I	Multi-purpose Input signal
12	EXGND		Ext. power ground	62	EXGND		Ext. power ground
13	EA0+	I	Encoder A-phase (+)	63	EA2+	I	Encoder A-phase (+)
14	EA0-	I	Encoder A-phase (-)	64	EA2-	I	Encoder A-phase (-)
15	EB0+	I	Encoder B-phase (+)	65	EB2+	I	Encoder B-phase (+)
16	EB0-	I	Encoder B-phase (-)	66	EB2-	I	Encoder B-phase (-)
17	EZ0+	I	Encoder Z-phase (+)	67	EZ2+	I	Encoder Z-phase (+)
18	EZ0-	I	Encoder Z-phase (-)	68	EZ2-	I	Encoder Z-phase (-)
19	VDD	O	+5V power supply output	69	VDD	O	+5V power supply output
20	EXGND	-	Ext. power ground	70	EXGND	-	Ext. power ground
21	OUT1+	O	Pulse signal (+)	71	OUT3+	O	Pulse signal (+)

#	Name	I/O	Function	#	Name	I/O	Function
22	OUT1-	O	Pulse signal (-)	72	OUT3-	O	Pulse signal (-)
23	DIR1+	O	Dir. signal (+)	73	DIR3+	O	Dir. signal (+)
24	DIR1-	O	Dir. signal (-)	74	DIR3-	O	Dir. signal (-)
25	SVON1	O	Servo On/Off	75	SVON3	O	Servo On/Off
26	ERC1	O	Dev. ctr, clr. Signal	76	ERC3	O	Dev. ctr, clr. signal
27	ALM1	I	Alarm signal	77	ALM3	I	Alarm signal
28	INP1	I	In-position signal	78	INP3	I	In-position signal
29	RDY1	I	Multi-purpose Input signal	79	RDY3	I	Multi-purpose Input signal
30	EXGND		Ext. power ground	80	EXGND		Ext. power ground
31	EA1+	I	Encoder A-phase (+)	81	EA3+	I	Encoder A-phase (+)
32	EA1-	I	Encoder A-phase (-)	82	EA3-	I	Encoder A-phase (-)
33	EB1+	I	Encoder B-phase (+)	83	EB3+	I	Encoder B-phase (+)
34	EB1-	I	Encoder B-phase (-)	84	EB3-	I	Encoder B-phase (-)
35	EZ1+	I	Encoder Z-phase (+)	85	EZ3+	I	Encoder Z-phase (+)
36	EZ1-	I	Encoder Z-phase (-)	86	EZ3-	I	Encoder Z-phase (-)
37	PEL0	I	End limit signal (+)	87	PEL2	I	End limit signal (+)
38	MEL0	I	End limit signal (-)	88	MEL2	I	End limit signal (-)
39	GDI0	I	DI/LTC/PCS/SD/CLR0	89	GDI2	I	DI/LTC/PCS/SD/CLR2
40	DO0	O	General Output 0	90	DO2	O	General Output 2
41	ORG0	I	Origin signal	91	ORG2	I	Origin signal
42	EXGND		Ext. power ground	92	EXGND		Ext. power ground
43	PEL1	I	End limit signal (+)	93	PEL3	I	End limit signal (+)

#	Name	I/O	Function	#	Name	I/O	Function
44	MEL1	I	End limit signal (-)	94	MEL3	I	End limit signal (-)
45	GDI1	I	DI/LTC/PCS/SD/CLR1/EMG	95	GDI3	I	DI/LTC/PCS/SD/CLR3
46	DO1	O	General Output 1	96	DO3	O	General Output 3
47	ORG1	I	Origin signal	97	ORG3	I	Origin signal
48	EXGND	-	Ext. power ground	98	EXGND	-	Ext. power ground
49	EXGND	-	Ext. power ground	99	E_24V	-	Isolation power Input, +24V
50	EXGND	-	Ext. power ground	100	E_24V	-	Isolation power Input, +24V

## 1.7 K1/K2 Pin Assignments: Simultaneous Start/Stop

K1 and K2 are for simultaneous start/stop signals for multiple axes or multiple cards.

No.	Name	Function
1	N/C	
2	STA	Simultaneous start signal input/output
3	STP	Simultaneous stop signal input/output
4	GND	PCIe bus power ground

GND pins are powered by PCIe bus.

## 1.8 P1 Manual Pulse Generator

#	Name	Function (Axis)
1	VDD	Isolated Power +5V
2	PA+	Manual Pulse Generator A+ phase signal input
3	PA-	Manual Pulse Generator A- phase signal input

#	Name	Function (Axis)
4	PB+	Manual Pulse Generator B+ phase signal input
5	PB-	Manual Pulse Generator B- phase signal input
6	EXGND	External Ground
7	N/A	Not Available
8	N/A	Not Available
9	N/A	Not Available

**Table 1-1: P1 Manual Pulse Generator**



NOTE:

Refer to the contents of this chapter before wiring any cable between the PCIe-8154 and any motor driver

## 1.9 CN5 Pin Assignments: TTL I/O

#	Name	I/O	Function	#	Name	I/O	Function
1	DGND	N/A	Power ground	2	DGND	N/A	Power ground
3	EDI0	I	Digital Input 0	4	EDI1	I	Digital Input 1
5	EDI2	I	Digital Input 2	6	EDI3	I	Digital Input 3
7	EDI4	I	Digital Input 4	8	EDI5	I	Digital Input 5
9	VCC	O	Power +3.3V	10	DGND	N/A	Power ground
11	EDI6	I	Digital Input 6	12	EDI7	I	Digital Input 7
13	EDI8	I	Digital Input 8	14	EDI9	I	Digital Input 9
15	EDI10	I	Digital Input 10	16	EDI11	I	Digital Input 11
17	DGND	N/A	Power ground	18	DGND	N/A	Power ground
19	EDI12	I	Digital Input 12	20	EDI13	I	Digital Input 13
21	EDI14	I	Digital Input 14	22	EDI15	I	Digital Input 15
23	EDO0	O	Digital Output 0	24	EDO1	O	Digital Output 1
25	EDO2	O	Digital Output 2	26	EDO3	O	Digital Output 3
27	DGND	N/A	Power ground	28	DGND	N/A	Power ground
29	EDO4	O	Digital Output 4	30	EDO5	O	Digital Output 5
31	EDO6	O	Digital Output 6	32	EDO7	O	Digital Output 7

#	Name	I/O	Function	#	Name	I/O	Function
33	EDO8	O	Digital Output 8	34	EDO9	O	Digital Output 9
35	DGND	N/A	Power ground	36	VCC	O	Power +3.3V
37	EDO10	O	Digital Output 10	38	EDO11	O	Digital Output 11
39	EDO12	O	Digital Output 12	40	EDO13	O	Digital Output 13
41	EDO14	O	Digital Output 14	42	EDO15	O	Digital Output 15
43	DGND	N/A	Power ground	44	DGND	N/A	Power ground

**Figure 1-3: IDE 44-pin Connector Assignment**

#	Name	I/O	Function	#	Name	I/O	Function
1	DGND	N/A	Power ground	20	DGND	N/A	Power ground
2	EDI0	I	Digital Input 0	21	EDO0	O	Digital Output 0
3	EDI1	I	Digital Input 1	22	EDO1	O	Digital Output 1
4	EDI2	I	Digital Input 2	23	EDO2	O	Digital Output 2
5	EDI3	I	Digital Input 3	24	EDO3	O	Digital Output 3
6	EDI4	I	Digital Input 4	25	EDO4	O	Digital Output 4
7	EDI5	I	Digital Input 5	26	EDO5	O	Digital Output 5
8	EDI6	I	Digital Input 6	27	EDO6	O	Digital Output 6
9	EDI7	I	Digital Input 7	28	EDO7	O	Digital Output 7
10	EDI8	I	Digital Input 8	29	EDO8	O	Digital Output 8
11	EDI9	I	Digital Input 9	30	EDO9	O	Digital Output 9
12	EDI10	I	Digital Input 10	31	EDO10	O	Digital Output 10
13	EDI11	I	Digital Input 11	32	EDO11	O	Digital Output 11
14	EDI12	I	Digital Input 12	33	EDO12	O	Digital Output 12
15	EDI13	I	Digital Input 13	34	EDO13	O	Digital Output 13
16	EDI14	I	Digital Input 14	35	EDO14	O	Digital Output 14
17	EDI15	I	Digital Input 15	36	EDO15	O	Digital Output 15
18	DGND	N/A	Power ground	37	DGND	N/A	Power ground
19	VCC	O	Power +3.3V	N/A	N/A	N/A	N/A

**Figure 1-4: DSUB 37-pin Connector Assignment**



## 2 Getting Started

### 2.1 Package Contents

In addition to this *User's Guide*, the package also includes the following items:

- ▶ PCIe-8154: advanced 4-axis servo/stepper motion control card
- ▶ General-purpose TTL I/O accessory cable (for CN5)



NOTE:

The terminal board is an optional accessory and is not included in the PCIe-8154 package.

---

If any of these items are missing or damaged, contact the dealer. Save the shipping materials and carton to ship or store the product in the future.

### 2.2 PCIe-8154 Hardware Installation

#### Hardware Configuration

The PCIe-8154 is fully Plug-and-Play compliant. Hence, memory allocation (I/O port locations) and IRQ channel of the PCIe card are assigned by the system BIOS. Addresses are assigned on a board-by-board basis for all PCIe cards in the system.

#### PCIe Slot Selection

The PCIe-8154 can be installed in any PCIe slot.

## Installation Procedures

1. Read through the manual and set up the jumpers according to your needs
2. Turn off the computer and all connected accessories (printer, modem, monitor, etc.). Remove the cover.
3. Select a PCIe expansion slot.
4. Before handling the PCIe-8154, discharge any static buildup by touching the metal case of the computer. Hold the edge of the card and do not touch the components.
5. Position the board into the selected PCIe slot.
6. Secure the card in place at the rear panel of the system unit using screws removed from the slot.

### Troubleshooting:

If the system doesn't boot or erratic operations occur with the PCIe board in place, an interrupt conflict is likely. Please consult the BIOS documentation.

Ensure the Control Panel lists the card. If not, check PCIe settings in BIOS or change PCIe slots.

## 2.3 Software Driver Installation

1. Run PCIe-8154 SDK.
2. Follow the procedures as instructed.
3. After setup installation is completed, restart Windows.



NOTE:

Ensure the latest software version from the ADLINK website is installed

---

## 2.4 JP2 to JP8 Jumper Setting for Pulse Output

J1-J8 set the type of output pulse signals (DIR and OUT), which can either be differential line driver or open collector output. Please see “Pulse Output Signals OUT and DIR on CN2” on page 16. for details. The default setting is differential line driver mode. Mapping is as follows:

JP1 & JP2	Axis 0
JP3 & JP4	Axis 1
JP5 & JP6	Axis 2
JP7 & JP8	Axis 3

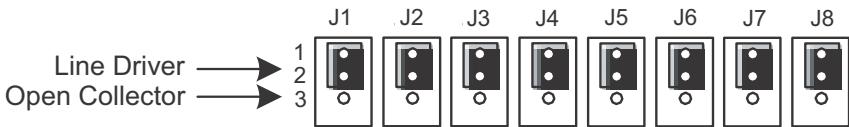

Figure 2-1: Jumper Settings

## 2.5 SW1 Card Index Selection

The SW1 switch is used to set the card index. For example, if 1 is set to ON and the others are OFF, that card index is 1. The index value can be from 0 to 15. Refer to the following table for details.

Card ID	Switch Setting (ON=1)
0	0000
1	0001
2	0010
3	0011
4	0100
5	0101
6	0110
7	0111
8	1000
9	1001
10	1010

Card ID	Switch Setting (ON=1)
11	1011
12	1100
13	1101
14	1110
15	1111

**Table 2-1: SW1 Card Index**

## 2.6 Signal Connections

### 2.6.1 Pulse Output Signals OUT and DIR on CN2

With 4 axes pulse output signals on the PCIe-8154, each axis uses two pairs of OUT and DIR differential signals to transmit the pulse train and indicate the direction. The OUT and DIR signals can also be programmed as CW and CCW signal pairs. Each signal consists of a pair of differential signals. For example, OUT0 consists of OUT0+ and OUT0- signals.

CN2 Pin.	Signal Name	Description	Axis #
3	OUT0+	Pulse signals (+)	0
4	OUT0-	Pulse signals (-)	0
5	DIR0+	Direction signal (+)	0
6	DIR0-	Direction signal (-)	0
21	OUT1+	Pulse signals (+)	1
22	OUT1-	Pulse signals (-)	1
23	DIR1+	Direction signal (+)	1
24	DIR1-	Direction signal (-)	1
53	OUT2+	Pulse signals (+)	2
54	OUT2-	Pulse signals (-)	2
55	DIR2+	Direction signal (+)	2
56	DIR2-	Direction signal (-)	2
71	OUT3+	Pulse signals (+)	3
72	OUT3-	Pulse signals (-)	3
73	DIR3+	Direction signal (+)	3

CN2 Pin.	Signal Name	Description	Axis #
74	DIR3-	Direction signal (-)	3

**Table 2-2: Pulse Output Signals on CN3**

The output of the OUT or DIR signals can be configured by jumpers as either differential line drivers or open collector output. Users can select the output mode either by jumper wiring between 1 and 2 or 2 and 3 of jumpers J1 to J8 as follows:

Output Signal	For differential line driver output, close 1 and 2 on:	For open collector output, close 2 and 3 on:
OUT0+	J1	J1
DIR0+	J2	J2
OUT1+	J3	J3
DIR1+	J4	J4
OUT2+	J5	J5
DIR2+	J6	J6
OUT3+	J7	J7
DIR3+	J8	J8

**Table 2-3: OUT or DIR Output by Jumper**

The default setting of OUT and DIR is differential line driver mode.

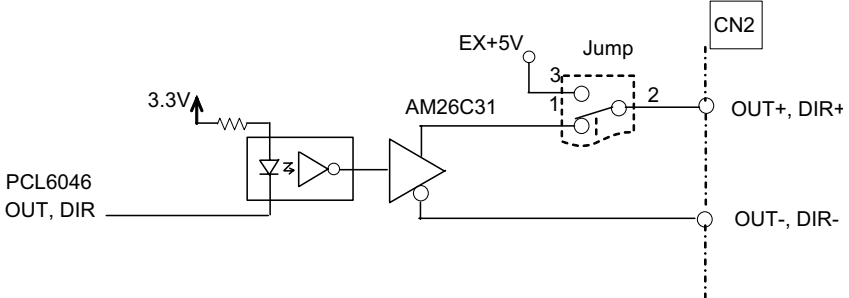
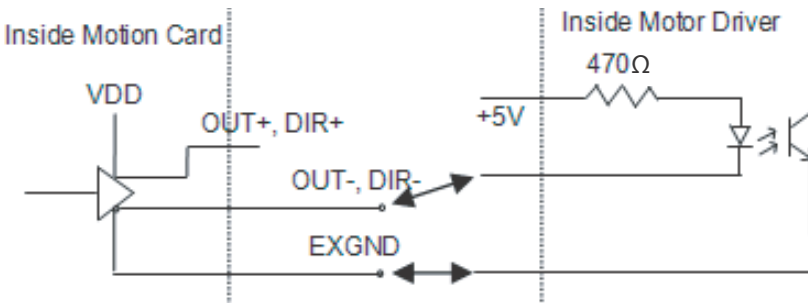

**Figure 2-2: OUT and DIR Axis Signals**



If the pulse output is set to open collector output mode, OUT- and DIR- transmit OUT and DIR signals, with sink current not exceeding 20mA on the OUT- and DIR- pins, and default setting 1-2 shorted

OUT-/DIR- can connect to a 470Ω pulse input interface COM via J2/J3. Choose OUT-/DIR- to connect to OUT/DIR.



**Figure 2-3: OUT/DIR through J2/J3 Connection**



Sink current exceeding 20mA will damage the 26LS31.

## 2.6.2 Encoder Feedback Signals EA, EB and EZ

The encoder feedback signals include EA, EB, and EZ. Every axis has six pins for three differential pairs of phase-A (EA), phase-B (EB), and index (EZ) inputs. EA and EB are used for position counting, and EZ is used for zero position indexing. Its relative signal names, pin numbers, and axis numbers are as follows.

CN2 Pin	Signal Name	Axis #	CN2 Pin	Signal Name	Axis #
13	EA0+	0	14	EA0-	0

CN2 Pin	Signal Name	Axis #	CN2 Pin	Signal Name	Axis #
15	EB0+	0	16	EB0-	0
17	EZ0+	0	18	EZ0-	0
31	EA1+	1	32	EA1-	1
33	EB1+	1	34	EB1-	1
35	EZ1+	1	36	EZ1-	1
63	EA2+	2	64	EA2-	2
65	EB2+	2	66	EB2-	2
67	EZ2+	2	68	EZ2-	2
81	EA3+	3	82	EA3-	3
83	EB3+	3	84	EB3-	3
85	EZ3+	3	86	EZ3-	3

**Table 2-4: EA, EB, and EZ Pin Assignments**

The input circuit of the EA, EB, and EZ signals is as shown.

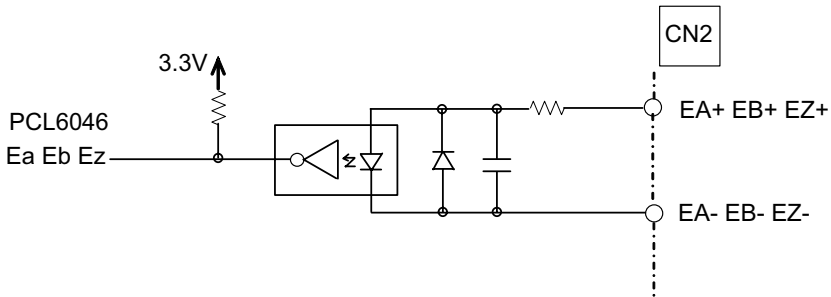

**Figure 2-4: EA, EB, and EZ Input Circuits**

Please note that the voltage across each differential pair of encoder input signals (EA+, EA-), (EB+, EB-), and (EZ+, EZ-) should be at least 3.5V. Therefore, the output current must be observed when connecting to the encoder feedback or motor driver feedback as not to over drive the source. The differential signal pairs are converted to digital signals EA, EB, and EZ; then feed to the motion control ASIC.

Examples of connecting the input signals with an external circuit include the input circuit connected to an encoder or motor driver if

it is equipped with: (1) a differential line driver or (2) an open collector output.

### Connection to Line Driver Output

To drive the PCIe-8154 encoder input, the driver output must provide at least 3.5V across the differential pairs with at least 8mA driving capacity. The grounds of both sides must be tied together. The maximum frequency is 3Mhz or more depends on wiring distance and signal conditioning.

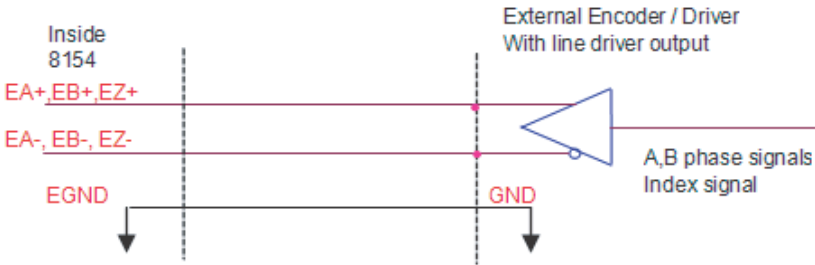

**Figure 2-5: Line Driver Connection Output Circuit**

### Connection to Open Collector Output

To connect with an open collector output, an external power supply is necessary. Some motor drivers can provide the power source. The connection between the PCIe-8154, encoder, and the power supply is as shown. Note that an external current limiting resistor R is necessary to protect the PCIe-8154 input circuit.

Encoder Power (V)	External Resistor R
+5V	0 $\Omega$ (None)
+12V	1.5k $\Omega$
+24V	3.0k $\Omega$

**Table 2-5: Device/Encoder/Power Connection**



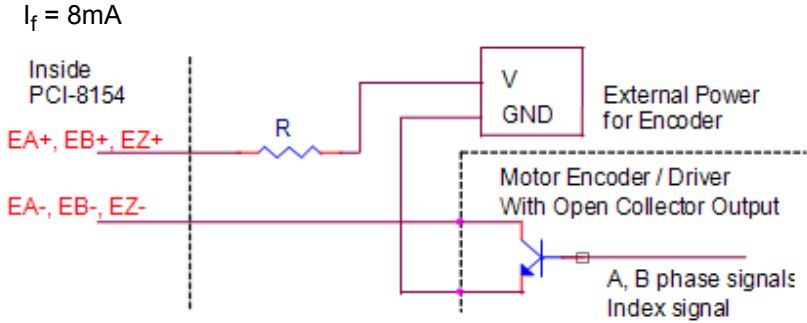

**Figure 2-6: Device/Encoder Connection Circuit**

### 2.6.3 Origin Signal ORG

The origin signals (ORG0-ORG3) are used as input signals for the origin of the mechanism. The following table lists signal names, pin numbers, and axis numbers:

CN2 Pin #	Signal Name	Axis #
41	ORG0	0
47	ORG1	1
91	ORG2	2
97	ORG3	3

**Table 2-6: ORG0-ORG3 Pin Assignments**

With the input circuit of the ORG signals, a limit switch is normally used to indicate the origin on one axis. The specifications of the limit switch should have contact capacity of +24V @ 6mA mini-

mum. An internal filter circuit filters out any high frequency spikes, which may cause errors in the operation.

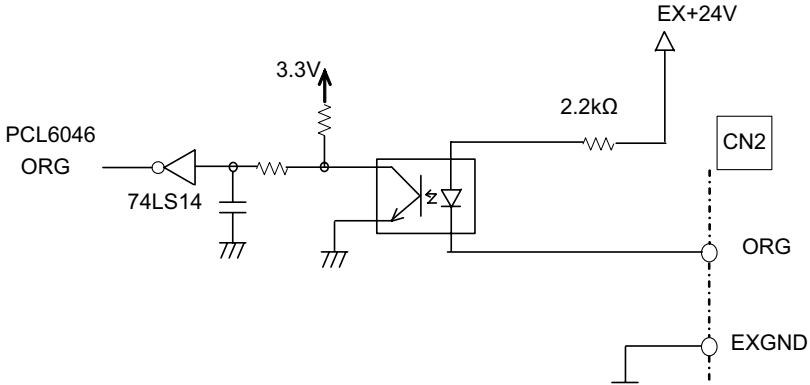

**Figure 2-7: ORG Input Circuit**

When the motion controller is operated in the home return mode, the ORG signal is used to inhibit the control output signals (OUT and DIR). For detailed operations of the ORG signal, refer to section 4.3.3.

## 2.6.4 End-Limit Signals PEL and MEL

The end-limit signals for each axis, can be in the plus direction (PEL), or the minus direction (MEL), configured as follows.

CN2 Pin	Signal Name	Axis #	CN2 Pin	Signal Name	Axis #
37	PEL0	0	38	MEL0	0
43	PEL1	1	44	MEL1	1
87	PEL2	2	88	MEL2	2
93	PEL3	3	94	MEL3	3

**Table 2-7: End-Limit Signal Pin Assignment**

As shown, the external limit switch should have a minimum contact capacity of +24V @ 8mA. Either ‘A-type’ (normal open) or ‘B-type’ (normal closed) contact switches can be used.

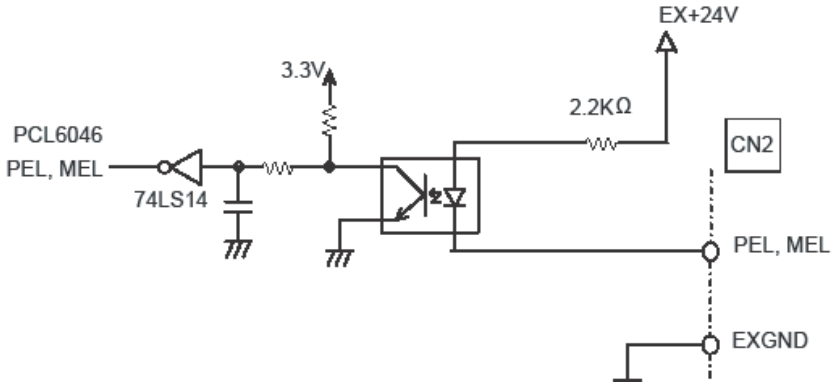

**Figure 2-8: End-Limit Signals Circuit**

### 2.6.5 In-Position Signal INP

The in-position signal INP from a servo motor driver indicates its deviation error. If there is no deviation error then the servo’s position indicates zero.

CN2 Pin	Signal Name	Axis #
10	INP0	0
28	INP1	1
60	INP2	2
78	INP3	3

**Table 2-8: INP Signal Connection**

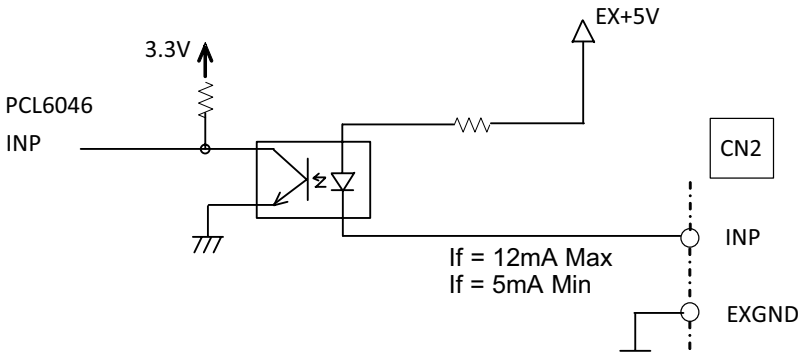

**Figure 2-9: INP Signal Circuit**

The in-position signal is usually generated by the servomotor driver and is ordinarily an open collector output signal. An external circuit must provide at least 8mA current sink capabilities to drive the INP signal.

### 2.6.6 Alarm Signal ALM

The alarm signal ALM is used to indicate the alarm status from the servo driver.

CN2 Pin	Signal Name	Axis #
9	ALM0	0
27	ALM1	1
59	ALM2	2
77	ALM3	3

**Table 2-9: Alarm Signal Connection**

The ALM signal is normally an open collector output signal generated by the servomotor driver. An external circuit must provide at least 8mA current sink capabilities to drive the ALM signal.

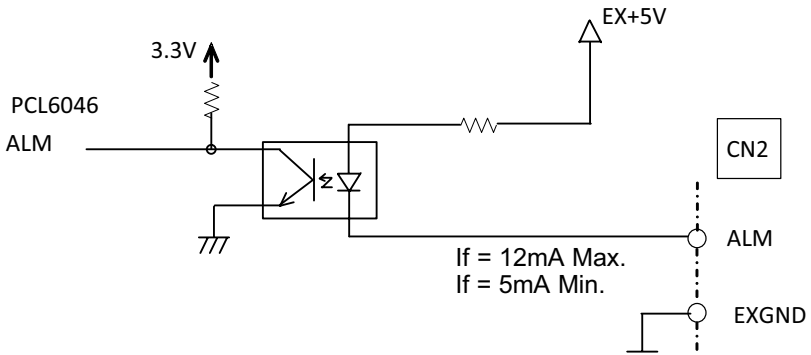

**Figure 2-10: Input Alarm Circuit**

### 2.6.7 Deviation Counter Clear Signal ERC

The deviation counter clear signal (ERC) is active when:

- ▶ Home return is complete
- ▶ End-limit switch is active
- ▶ An alarm signal stops OUT and DIR signals
- ▶ An emergency stop command is issued by software (operator)

CN2 Pin	Signal Name	Axis #
8	ERC0	0
26	ERC1	1
58	ERC2	2
76	ERC3	3

**Table 2-10: ERC Connection**

The ERC signal is used to clear the deviation counter of the servomotor driver. The ERC output circuit is an open collector with a maximum of 35V at 50mA driving capacity.

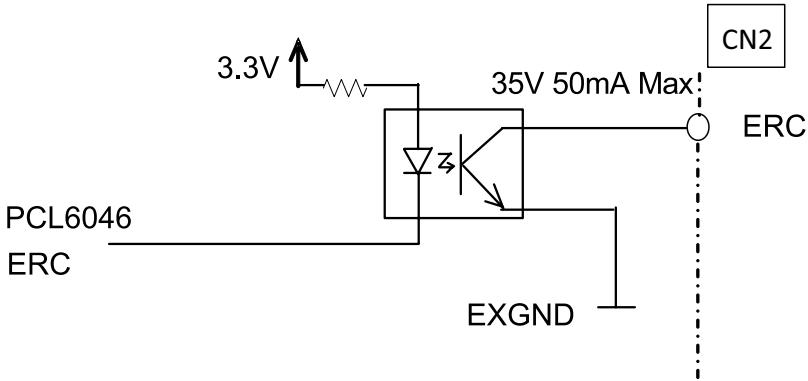

**Figure 2-11: ERC Circuit**

## 2.6.8 General-purpose Signal SVON

The SVON signal can be used as a servomotor-on control or general purpose output signal.

CN2 Pin	Signal Name	Axis #
7	SVON0	0
25	SVON1	1
57	SVON2	2
75	SVON3	3

**Table 2-11: SVON Connection**

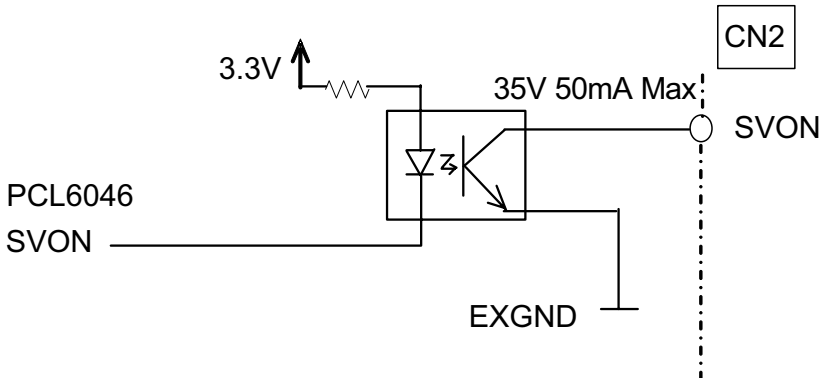

Figure 2-12: SVON Circuit

### 2.6.9 General-purpose Signal RDY

The RDY signals can be used as motor driver ready input or general purpose input signals.

CN2 Pin	Signal Name	Axis #
11	RDY0	0
29	RDY1	1
61	RDY2	2
79	RDY3	3

Table 2-12: RDY Signal Connection

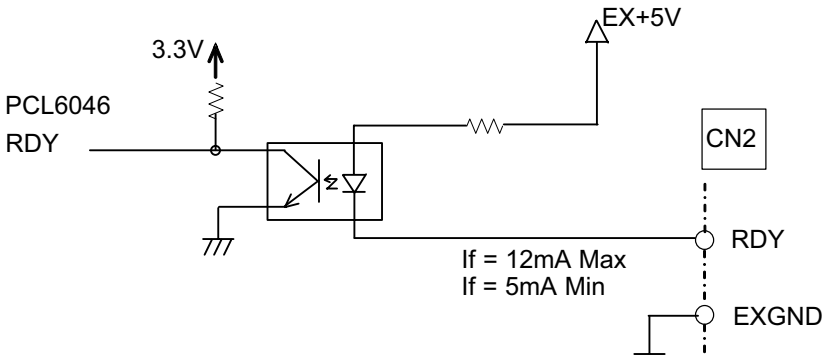

**Figure 2-13: RDY Circuit**

### 2.6.10 Multi-Functional Output Pin: DO/CMP

The PCIe-8154 provides multi-functional output channels DO0/CMP0 to DO3/CMP3, corresponding to 4 axes. Each output pin can be individually configured as Digit Output (DO) or as Comparison Output (CMP). When configured as a Comparison Output pin, the pin generates a pulse signal when the encoder counter matches a preset value.

CN2 Pin	Signal Name	Axis #
40	DO/CMP0	0
46	DO/CMP1	1
90	DO/CMP2	2
96	DO/CMP3	3

**Table 2-13: DO/CMP Connection**



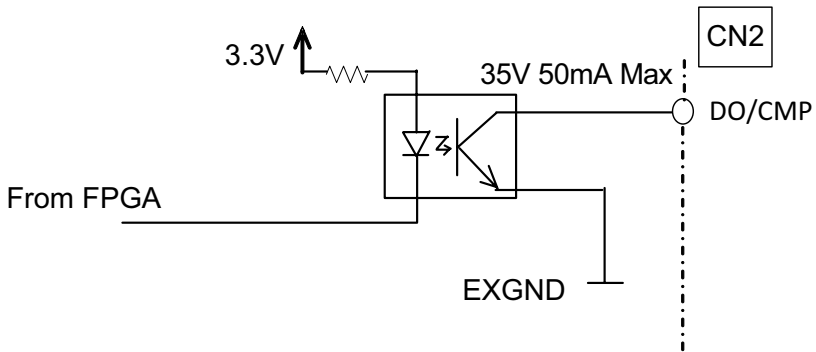

Figure 2-14: DO/CMP Circuit

### 2.6.11 Multi-Functional Input Pin: DI/LTC/SD/PCS/CLR/EMG

Each of the 4 multi-functional input pins on CN2 can be configured as DI (Digit Input), LTC (Latch), SD (Slow down), PCS (Target position override), CLR (Counter clear), or EMG (Emergency).

CN2 Pin	Signal Name	Axis #
39	DI/LTC/SD/PCS/CLR/EMG_0	0
45	DI/LTC/SD/PCS/CLR/EMG_1	1
89	DI/LTC/SD/PCS/CLR/EMG_2	2
95	DI/LTC/SD/PCS/CLR/EMG_3	3

Table 2-14: DI/LTC/SD/PCS/CLR/EMG Connection

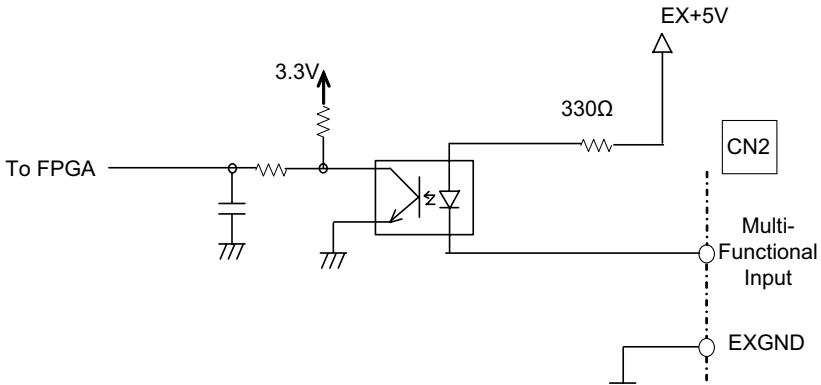

**Figure 2-15: DI/LTC/SD/PCS/CLR/EMG Circuit**

## 2.6.12 Manual Pulse Generator Input Signals PA and PB

The PCIe-8154 can accept differential manual pulse generator input signals through the pins of P1 listed below. The manual pulse generator acts as an encoder, with A-B phase signals generating positioning information to guide the motor.

P1 Pin	Signal Name	Axis #	P1 Pin	Signal Name	Axis #
2	PA+	0-3	3	PA-	0-3
4	PB+	0-3	5	PB-	0-3

**Table 2-15: Manual Pulse Generator Input Signal Connection**

The manual pulse generator signals are used for axes 0 to 3, where each axis' manual pulse generator can be disabled with the `_8154_disable_pulser_input` function.

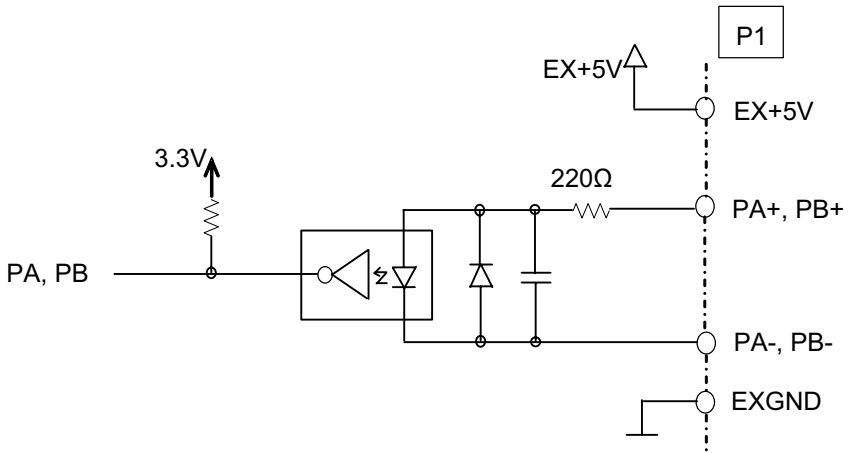

**Figure 2-16: Manual Pulse Generator Input Signal Circuit**

### 2.6.13 Simultaneous Start/Stop Signals STA and STP

The PCIe-8154 provides STA and STP signals, which enable simultaneous starting and stopping of motion on multiple axes. The STA and STP signals are on K1/K2.

The STP and STA signals are both input and output signals. To start and stop simultaneously, both software control and external control are needed. With software control, the signals can be generated from any connected PCIe-8154. Alternatively, an external open collector or switch can drive the STA/STP signals for simultaneous start and stop.

If there are two or more PCIe-8154 cards, connect the K2 connector on the previous card to K1 connector on the next card. K1 and K2 connectors on the same PCIe-8154 are connected internally.

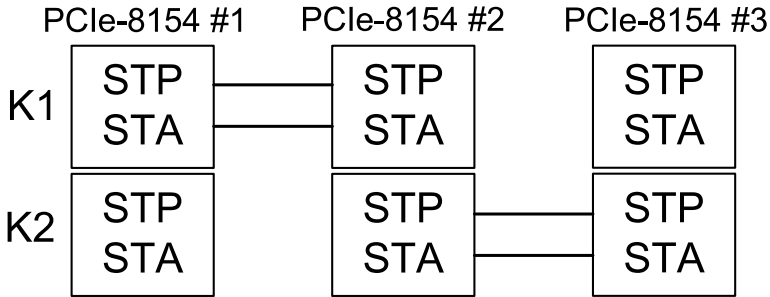

**Figure 2-17: STA & STP Connection**

External start and stop signals can initiate simultaneous cross-card motor operations, when connected to STA and STP pins on the K1 connector.

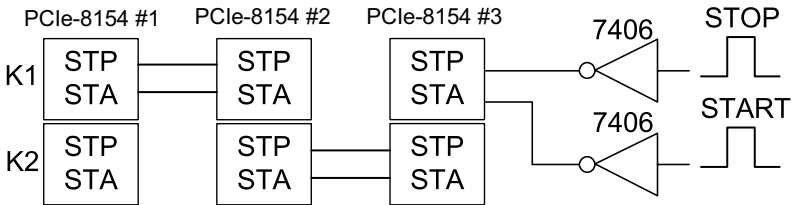

**Figure 2-18: STA & STP Connection With External Start/Stop**

## 2.6.14 General Purpose TTL I/O EDI And EDO

32 general purpose TTL digital input/ outputs are provided on CN5.

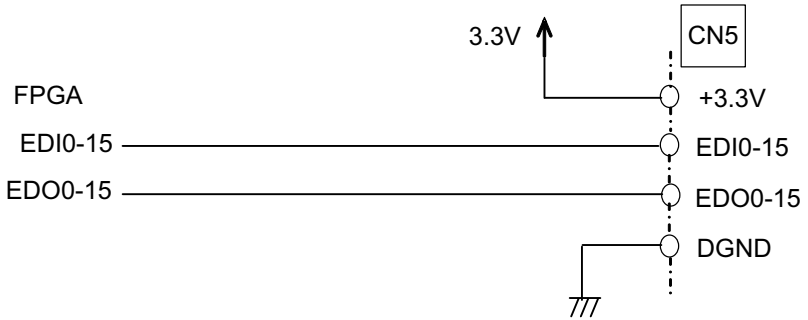

Figure 2-19: EDI And EDO Circuit

This page intentionally left blank.

# Appendix A MotionCreatorPro

After installing the hardware, it is necessary to correctly configure all cards and check the system. MotionCreatorPro provides simple yet powerful setup, configuration, testing, and debugging for motion control systems using 8154 cards.

MotionCreatorPro functions under Windows XP/7/8.1. Recommended screen resolution is 1024x768.

## A.1 About MotionCreatorPro

Before running MotionCreatorPro, please note the following.

1. MotionCreatorPro is written in VB.NET 2003.
2. MotionCreatorPro allows settings and configurations for 8154 cards to be saved. Saved configurations will be automatically loaded the next time MotionCreatorPro is executed. Two files, **8154.ini** and **8154MC.ini**, in the **windows root directory** are used to save all settings and configurations.
3. To duplicate configurations from one system to another, copy 8154.ini and 8154MC.ini into the Windows root directory.
4. If multiple 8154 cards use the same MotionCreatorPro saved configuration files, the DLL function call **\_8154\_config\_from\_file()** can be invoked within a user developed program. This function is available in a DOS environment as well.

## A.2 Initiating MotionCreatorPro

After installing the software drivers for the 8154 in Windows XP/7/8.1, the MotionCreatorPro program can be located at <chosen path>\ADLINK\8154\MotionCreatorPro. To execute the program, double click the executable file or use Start>Program Files>ADLINK>8154>MotionCreatorPro.

## A.3 MotionCreatorPro Introduction

### Main Menu

The main menu opens after starting MotionCreatorPro.

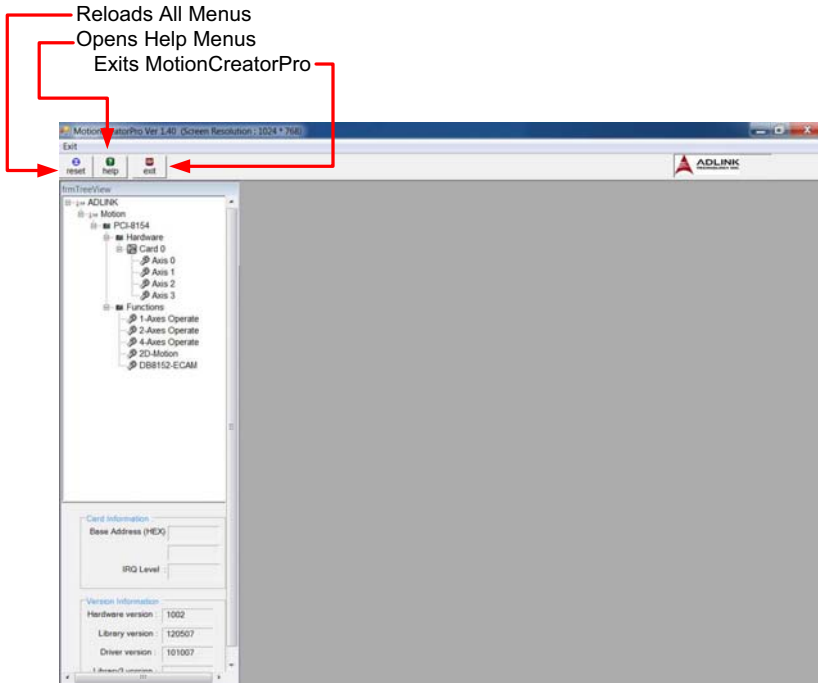



## Select Menu

The Select menu appears after starting MotionCreatorPro and enables selection of operating card and axis.

- Opens Card Information Menu
- Opens Configuration Menu
- Opens Single Axis Operation Menu
- Opens Two-Axis Operation Menu
- Opens Four-Axis Operation Menu
- Opens 2D-Motion Menu
- Displays Version Information

The screenshot shows the 'frmTreeView' window with the following structure:

- ADLINK
  - Motion
    - PCI-8154 (indicated by a red arrow from 'Opens Configuration Menu')
    - Hardware
      - Card 0 (indicated by a red arrow from 'Opens Card Information Menu')
      - Axis 0 (indicated by a red arrow from 'Opens Single Axis Operation Menu')
      - Axis 1 (indicated by a red arrow from 'Opens Two-Axis Operation Menu')
      - Axis 2 (indicated by a red arrow from 'Opens Two-Axis Operation Menu')
      - Axis 3 (indicated by a red arrow from 'Opens Two-Axis Operation Menu')
    - Functions
      - 1-Axes Operate (indicated by a red arrow from 'Opens Four-Axis Operation Menu')
      - 2-Axes Operate (indicated by a red arrow from 'Opens Four-Axis Operation Menu')
      - 4-Axes Operate (indicated by a red arrow from 'Opens Four-Axis Operation Menu')
      - 2D-Motion (indicated by a red arrow from 'Opens 2D-Motion Menu')

Below the tree view are two panels:

- Card Information :**
  - Base Address (HEX) [ ]
  - IRQ Level : [ ]
- Version Information :**
  - Hardware version : 1002
  - Library version : 120507
  - Driver version : 101007
  - Library2 version : [ ]

A red arrow from 'Displays Version Information' points to the 'Version Information' panel.

## Card Information Menu

Provides Information about the card:



## Configuration Menu

In the **IO\_Config\_1** menu, users can configure ALM, INP, ERC, EL, ORG, and EZ, as follows.

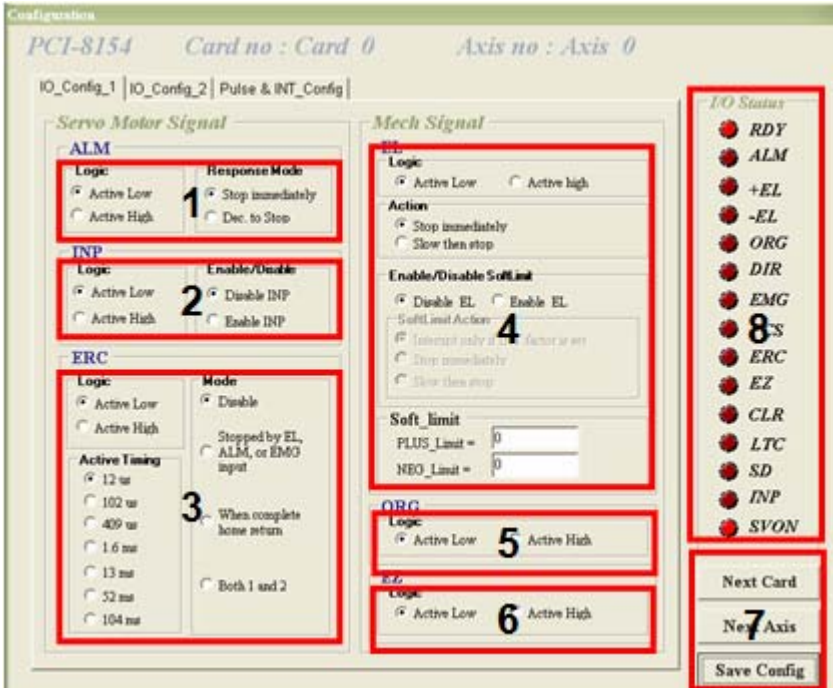

1. **ALM Logic and Response mode:** Select logic and response modes of ALM signal. The related function call is `_8154_set_alm()`.
2. **INP Logic and Enable/Disable selection:** Select logic, and Enable/ Disable the INP signal. The related function call is `_8154_set_inp()`
3. **ERC Logic, Active timing and ERC mode:** Select the Logic, Active timing and mode of the ERC signal. The related function call is `_8154_set_erc()`.
4. **EL Response mode:** Select the response mode of the EL signal. The related function call is `_8154_set_limit_logic()`.

5. **ORG Logic:** Select the logic of the ORG signal. The related function call is `_8154_set_home_config()`.
6. **EZ Logic:** Select the logic of the EZ signal. The related function call is `_8154_set_home_config()`.
7. **Buttons:**
  - ▷ **Next Card:** Change operating card.
  - ▷ **Next Axis:** Change operating axis.
  - ▷ **Save Config:** Save current configuration to 8154.ini and 8154MC.ini.
8. **I/O Status:** The status of motion I/O. Light-On means Active, while Light-Off indicates inactive. The related function is `_8154_get_io_status`

In the **IO\_Config\_2** menu, users can configure LTC, SD, PCS, and Select\_Input.

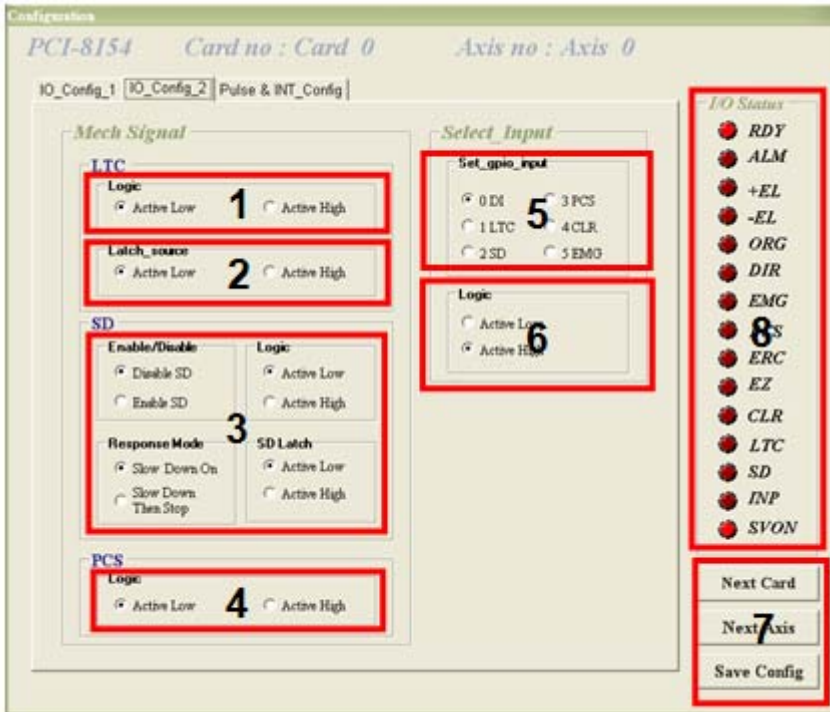

1. **LTC Logic:** Select the logic of the LTC signal. The related function call is `_8154_set_ltc_logic()`.
2. **LTC latch\_source:** Select the logic of the latch\_source signal. The related function call is `_8154_set_latch_source()`.
3. **SD Configuration:** Configure the SD signal. The related function call is `_8154_set_sd()`.
4. **PCS Logic:** Select the logic of the SelectNo signal. The related function call is `_8154_set_pcs_logic()`.
5. **Set gpio input:** Select the configurations of the gpio input. The related function call is `_8154_set_gpio_input_function`.
6. **Gpio Logic:** Select the logic of the gpio. The related function call is `_8154_set_gpio_input_function`.
7. **Buttons:**
  - ▷ **Next Card:** Change operating card.
  - ▷ **Next Axis:** Change operating axis.
  - ▷ **Save Config:** Save current configuration to 8154.ini And 8154MC.ini.
8. **I/O Status:** Displays I/O status, with lit indicating Active unlit inactive. The related function is `_8154_get_io_status`

In the **Pulse & INT\_Config** menu, users can configure pulse input/output and move ratio and INT factor.

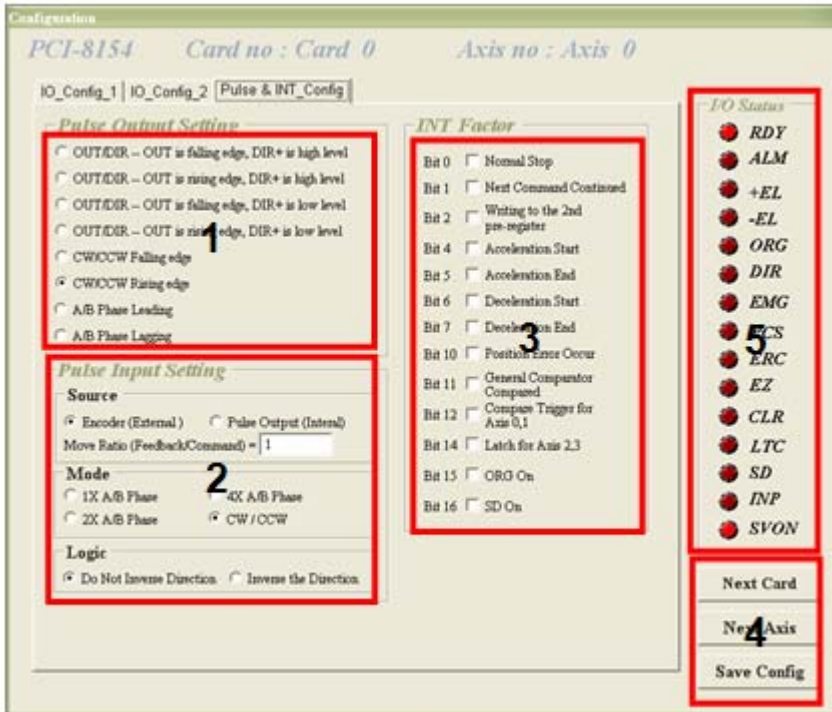

1. **Pulse Output Mode:** Select the output mode of the pulse signal (OUT/ DIR). The related function call is `_8154_set_pls_outmode()`.
2. **Pulse Input:** Sets the configurations of the Pulse input signal(EA/EB). The related function calls are `_8154_set_pls_ipmode()`, `_8154_set_feedback_src()`.
3. **INT Factor:** Select factors to initiate the event int. The related function call is `_8154_set_int_factor()`.
4. **Buttons:**
  - ▷ **Next Card:** Change operating card.
  - ▷ **Next Axis:** Change operating axis.

- ▷ **Save Config:** Save current configuration to 8154.ini And 8154MC.ini.

5. **I/O Status:** The status of motion I/O. Light-On means Active, while Light-Off indicates inactive. The related function is `_8154_get_io_status`.

### Single Axis Operation Menu

In this menu, users can change the settings for a specific axis, such as velocity mode motion, preset relative/absolute motion, manual pulse move, and home return.



#### 1. Position:

- ▷ **Command:** displays the value of the command counter. The related function is `_8154_get_command()`.

- ▷ **Feedback:** displays the value of the feedback position counter. The related function is `_8154_get_position()`
  - ▷ **Pos Error:** displays the value of the position error counter. The related function is `_8154_get_error_counter()`.
  - ▷ **Target Pos:** displays the value of the target position recorder. The related function is `_8154_get_target_pos()`.
2. **Position Reset:** Resets all positioning counters to a specified value. The related functions are:
- ▷ `_8154_set_position()`,
  - ▷ `_8154_set_command()`,
  - ▷ `_8154_reset_error_counter()`
  - ▷ `_8154_reset_target_pos()`
3. **Motion Status:** Displays the returned value of the `_8154_motion_done` function. The related function is `_8154_motion_done()`.
4. **INT Status:**
- ▷ **int\_factor bit no:** Set `int_factor` bit.
  - ▷ **Normal INT:** display of Normal INT status. The related function is `_8154_wait_motion_interrupt()`.
  - ▷ **Error INT:** display of Error INT status. The related function is `_8154_wait_error_interrupt()`.
  - ▷ **GPIO INT:** display of GPIO INT status. The related function is `_8154_wait_gpio_interrupt()`.
5. **Velocity:** The absolute value of velocity in units of PPS. The related function is `_8154_get_current_speed()`.
6. **Show Velocity Curve Button:** Clicking this button will open a window showing a velocity vs. time curve. In this curve, every 100ms, a new velocity data point will be added. To close, click again, and to clear data, click the curve.



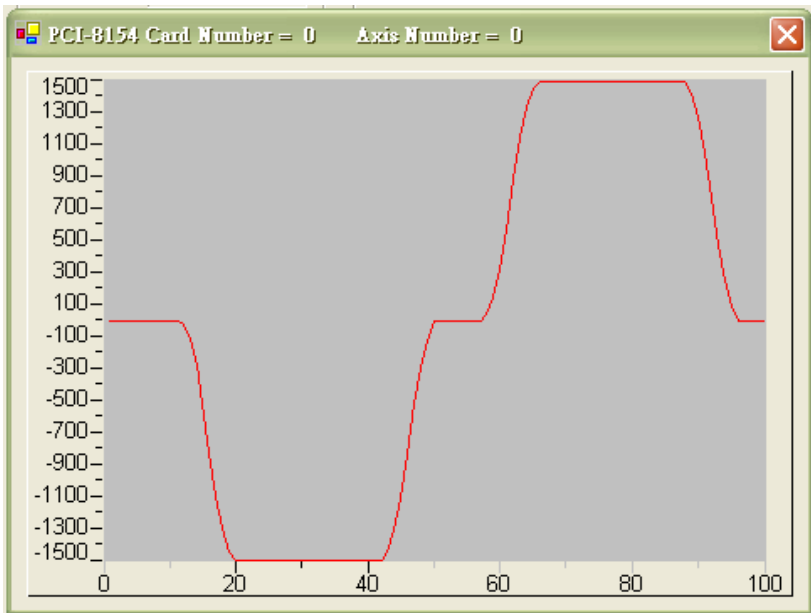

## 7. Operating Mode: Select operating mode.

- ▷ **Absolute Mode:** “Position1” and “position2” is used as absolute target positions for motion. The related functions are `_8154_start_ta_move()`, `_8154_start_sa_move()`.
- ▷ **Relative Mode:** “Distance” is used as relative displacement for motion. The related function is `_8154_start_tr_move()`, `_8154_start_sr_move()`.
- ▷ **Cont. Move:** Velocity motion mode. The related function is `_8154_tv_move()`, `_8154_start_sv_move()`.

- ▷ **Manual manual pulse generator Move:** Manual Pulse motion. Clicking this button will invoke the manual pulse configuration window.

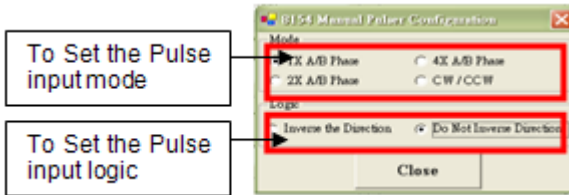

- ▷ **Home Mode:** Home return motion. Clicking this button will invoke the home move configuration window. The related function is `_8154_set_home_config()`. *If the check box "ATU" is checked, it will execute auto homing when motion starts.*

**ERC Output:** Select if the ERC signal will be sent when home move completes.

**EZ Count:** Set the EZ count number, which is effective on certain home return modes.

**Mode:** Select the home return mode. There are 13 modes available.

**Home Mode figure:** The figure shown explains the actions of the individual home modes.

**Close:** Click this button close this window.

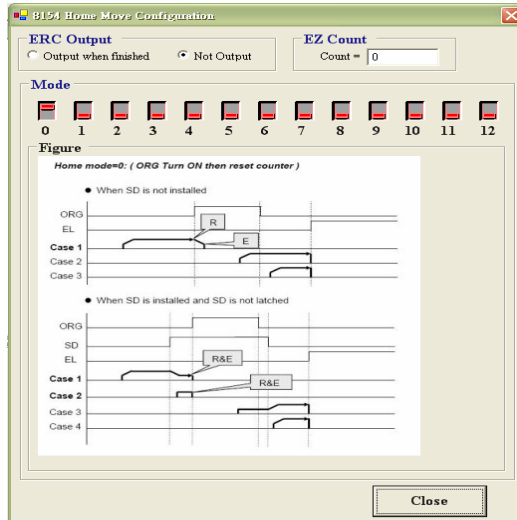

8. **Position:** Set the absolute position for “Absolute Mode.” It is only effective when “Absolute Mode” is selected.
9. **Distance:** Set the relative distance for “Relative Mode.” It is only effective when “Relative Mode” is selected.
10. **Repeat Mode:** When “On” is selected, the motion will become repeat mode (**forward<-->backward** or **position1<-->position2**). It is only effective when “Relative Mode” or “Absolute Mode” is selected.
11. **Vel. Profile:** Select the velocity profile. Both Trapezoidal and S-Curve are available for “Absolute Mode,” “Relative Mode,” and “Cont. Move.”
12. **FA Speed/ATU:** Sets the configurations of the FA Speed. The related function calls are `_8154_set_fa_speed()`. If the check box “ATU” is checked, it will execute auto homing when motion starts.
13. **Motion Parameters:** Set the parameters for single axis motion. This parameter is meaningless if “Manual man-

ual pulse generator Move” is selected, since the velocity and moving distance is decided by pulse input.

- ▷ **Start Velocity:** Set the start velocity of motion in units of PPS. In “Absolute Mode” or “Relative Mode,” only the value is effective. For example, -100.0 is the same as 100.0. In “Cont. Move,” both the value and sign are effective. -100.0 means 100.0 in the minus direction.
- ▷ **Maximum Velocity:** Set the maximum velocity of motion in units of PPS. In “Absolute Mode” or “Relative Mode,” only the value is effective. For example, -5000.0 is the same as 5000.0. In “Cont. Move,” both the value and

sing is effective.  $-5000.0$  means  $5000.0$  in the minus direction.

- ▷ **Accel. Time:** Set the acceleration time in units of second.
- ▷ **Decel. Time:** Set the deceleration time in units of second.
- ▷ **SVacc:** Set the S-curve range during acceleration in units of PPS.
- ▷ **SVdec:** Set the S-curve range during deceleration in units of PPS.
- ▷ **Move Delay:** This setting is effective only when repeat mode is set "On." It will cause the 8154 to delay for a specified time before it continues to the next motion.

**14.Speed\_Profile:** Clicking this button will show the Speed Profile.

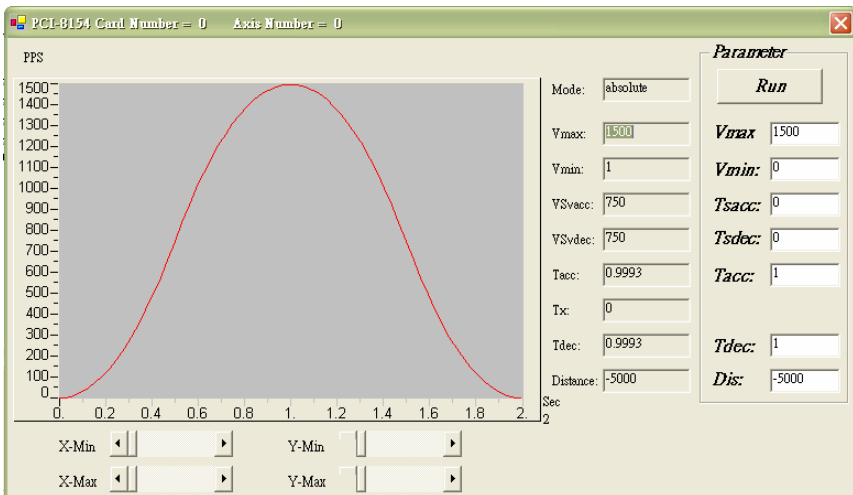

**15.Digital I/O:** Display and set Digital I/O. The related functions are: `_8154_get_gpio_output()`, `_8154_get_gpio_input()`, `_8154_set_gpio_output()`.

**16.Servo On:** Set the SVON signal output status. The related function is `_8154_set_servo()`.

**17.Play Key:**

**Left play button:** Causes the 8154 start to outlet pulses according to previous setting.

- ▷ In “Absolute Mode,” it causes the axis to move to position1.
- ▷ In “Relative Mode,” it causes the axis to move forward.
- ▷ In “Cont. Move,” it causes the axis to start to move according to the velocity setting.
- ▷ In “Manual manual pulse generator Move,” it causes the axis to go into pulse move. The speed limit is the value set by “Maximum Velocity.”

**Right play button:** Causes the 8154 start to outlet pulses according to previous setting.

- ▷ In “Absolute Mode,” it causes the axis to move to position.
- ▷ In “Relative Mode,” it causes the axis to move backwards.
- ▷ In “Cont. Move,” it causes the axis to start to move according to the velocity setting, but in the opposite direction.
- ▷ In “Manual manual pulse generator Move,” it causes the axis to go into pulse move. The speed limit is the value set by “Maximum Velocity.”

18. **Stop Button:** Causes the 8154 to decelerate and stop. The deceleration time is defined in “Decel. Time.” The related function is `_8154_sd_stop()`.

19. **I/O Status:** The status of motion I/O. Light-On means Active, while Light-Off indicates inactive. The related function is `_8154_get_io_status()`.

20. **Buttons:**

- ▷ **Next Card:** Change operating card.
- ▷ **Next Axis:** Change operating axis.
- ▷ **Save Config:** Save current configuration to 8154.ini And 8154MC.ini.
- ▷ **Close:** Close the menu.

## Two-Axis and Four-Axis Operation Menu

In two-axis and four-axis menu, users can change the settings of two or four selected axis, including velocity mode motion, preset relative/absolute motion. User can discover two-axis and four-

axis operation menu are similarly, that's because we just introduce two-axis menu.

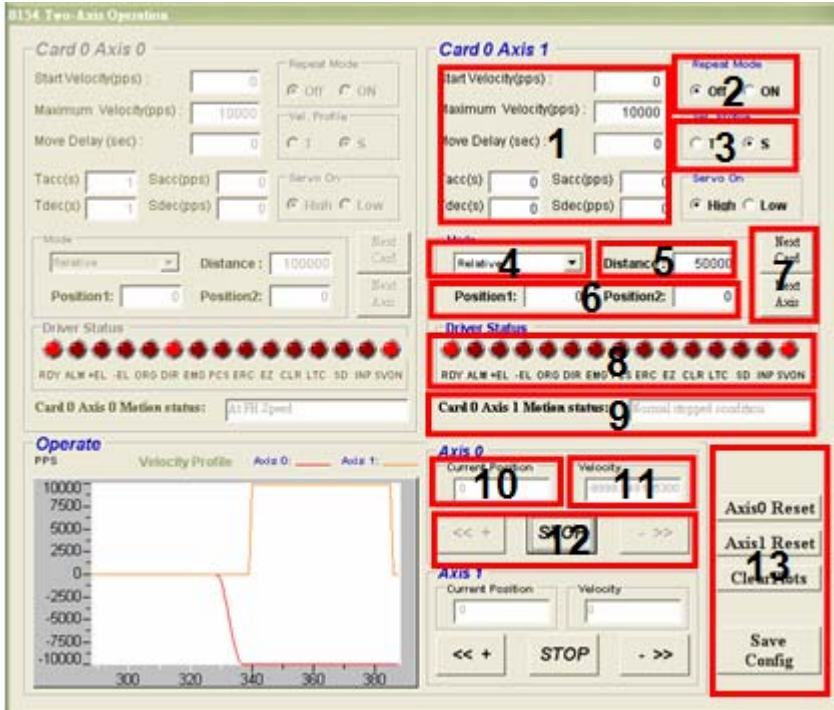

The screenshot displays the 'MotionCreatorPro' software interface for configuring two-axis operations. The interface is divided into several sections:

- Card 0 Axis 0:** Contains parameters for Start Velocity (pps), Maximum Velocity (pps), Move Delay (sec), acceleration (acc/s), deceleration (dec/s), and servo on/off settings. It also includes Mode selection (Relative, Absolute), Distance (100000), and Position (1, 2) settings.
- Card 0 Axis 1:** Similar to Card 0 Axis 0, but with highlighted parameters: Start Velocity (0), Maximum Velocity (10000), Move Delay (1), and Mode (Relative). The Distance is set to 50000.
- Driver Status:** Two rows of indicator lights for Card 0 Axis 0 and Card 0 Axis 1, with status text below them.
- Operate Section:** Features a Velocity Profile graph showing the movement of Axis 0 (orange) and Axis 1 (red) over time. The graph shows a step change in velocity for both axes.
- Axis 0 and Axis 1 Control:** Includes Current Position and Velocity displays, as well as control buttons for Home (Home), Stop (STOP), and Reset (Axis0 Reset, Axis1 Reset, Clear Axis).

Red boxes highlight the following numbered elements:

- Start Velocity (pps) for Card 0 Axis 1
- Repeat Mode (ON) for Card 0 Axis 1
- Move Delay (sec) for Card 0 Axis 1
- Mode (Relative) for Card 0 Axis 1
- Distance for Card 0 Axis 1
- Position 1 for Card 0 Axis 1
- Next Card for Card 0 Axis 1
- Driver Status indicator for Card 0 Axis 1
- Card 0 Axis 1 Motion status
- Current Position for Axis 0
- Velocity for Axis 0
- STOP button for Axis 0
- Axis0 Reset button
- Axis1 Reset button
- Clear Axis button



1. **Motion Parameters:** Set the parameters for single axis motion. This parameter is meaningless if “Manual manual pulse generator Move” is selected, since the velocity and moving distance is decided by pulse input.
  - ▷ **Start Velocity:** Set the start velocity of motion in units of PPS. In “Absolute Mode” or “Relative Mode,” only the value is effective. For example, -100.0 is the same as 100.0.
  - ▷ **Maximum Velocity:** Set the maximum velocity of motion in units of PPS. In “Absolute Mode” or “Relative Mode,” only the value is effective. For example, -5000.0 is the same as 5000.0.
  - ▷ **Tacc:** Set the acceleration time in units of second.
  - ▷ **Tdec:** Set the deceleration time in units of second.
  - ▷ **Sacc:** Set the S-curve range during acceleration in units of PPS.
  - ▷ **Sdec:** Set the S-curve range during deceleration in units of PPS.
2. **Repeat Mode:** When “On” is selected, the motion will become repeat mode (**forward<-->backward** or **position1<-->position2**). It is only effective when “Relative Mode” or “Absolute Mode” is selected.
3. **Vel. Profile:** Select the velocity profile. Both Trapezoidal and S-Curve are available for “Absolute Mode,” “Relative Mode,” and “Cont. Move.”
4. **Operating Mode:** Select operating mode.
  - ▷ **Absolute Mode:** “Position1” and “position2” is used as absolute target positions for motion. The related functions are `_8154_start_ta_move()`, `_8154_start_sa_move()`.
  - ▷ **Relative Mode:** “Distance” is used as relative displacement for motion. The related function is `_8154_start_tr_move()`, `_8154_start_sr_move()`.
5. **Distance:** Set the relative distance for “Relative Mode.” It is only effective when “Relative Mode” is selected.

6. **Position:** Set the absolute position for “Absolute Mode.” It is only effective when “Absolute Mode” is selected.
7. **Buttons:**
  - ▷ **Next Card:** Change operating card.
  - ▷ **Next Axis:** Change operating axis.
8. **I/O Status:** The status of motion I/O. Light-On means Active, while Light-Off indicates inactive. The related function is `_8154_get_io_status()`.
9. **Motion status:** Displays the returned value of the `_8154_motion_done` function. The related function is `_8154_motion_done()`.
10. **Current Position:**
  - ▷ **Command:** displays the value of the command counter. The related function is `_8154_get_position()`.
11. **Velocity:** The absolute value of velocity in units of PPS. The related function is `_8154_get_current_speed()`.
12. **Play Key:**

**Left play button:** Causes the 8154 start to outlet pulses according to previous setting.

  - ▷ In “Absolute Mode,” it causes the axis to move to position1.
  - ▷ In “Relative Mode,” it causes the axis to move forward.
  - ▷ Right play button: Causes the 8154 start to outlet pulses according to previous setting.
  - ▷ In “Absolute Mode,” it causes the axis to move to position2.
  - ▷ In “Relative Mode,” it causes the axis to move backwards.

**Stop Button:** Causes the 8154 to decelerate and stop. The deceleration time is defined in “Decel. Time.” The related function is `_8154_sd_stop()`.

### 13. Buttons:

- ▷ **Axis0 Reset:** clicking this button will set all positioning counters of selected axis to zero. The related functions are:
  - `_8154_set_position()`
  - `_8154_set_command()`
  - `_8154_reset_error_counter()`
  - `_8154_reset_target_pos()`
- ▷ **Axis1 Reset:** clicking this button will set all positioning counters of selected axis to zero.
- ▷ **ClearPlots:** Clear the Motion Graph.
- ▷ **Save Config:** Save current configuration to 8154.ini and 8154MC.ini.
- ▷ **Close:** Close the menu.

## 2D\_Motion Menu

Press 2-D button in operating window will enter this window. This is for 2-D motion test. It includes the following topics:

- ▷ Linear Interpolation
- ▷ Circular Interpolation
- ▷ Incremental Jog
- ▷ Continuous Jog
- ▷ Other Control Objects

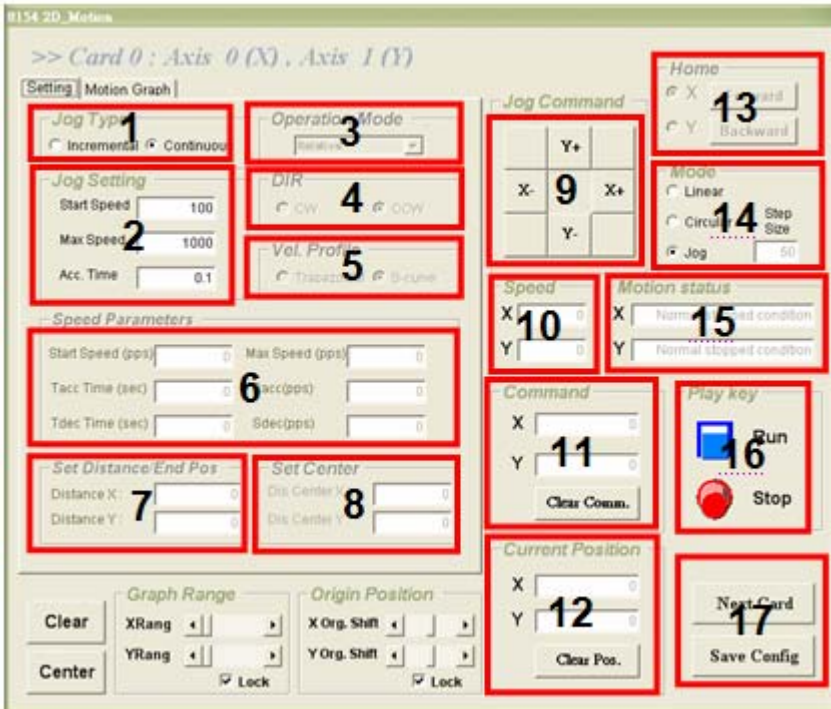

The screenshot shows the '2D\_Motion' control window for 'Card 0 : Axis 0 (X), Axis 1 (Y)'. The interface is divided into several functional areas:

- Jog Type (1):** Radio buttons for 'Incremental' and 'Continuous'.
- Jog Setting (2):** Input fields for 'Start Speed' (100), 'Max Speed' (1000), and 'Acc. Time' (0.1).
- Operation Mode (3):** A dropdown menu.
- DIR (4):** Radio buttons for 'CW' and 'CCW'.
- Vel. Profile (5):** Radio buttons for 'Trapez' and 'S-curve'.
- Speed Parameters (6):** Input fields for 'Start Speed (pps)', 'Max Speed (pps)', 'Tacc Time (sec)', and 'Sdec (pps)'. 'Tdec Time (sec)' and 'Sdec (pps)' are also present but not numbered.
- Set Distance-End Pos (7):** Input fields for 'Distance X' and 'Distance Y'.
- Set Center (8):** Input fields for 'Dis. Center X' and 'Dis. Center Y'.
- Jog Command (9):** A 2x2 grid of buttons for 'Y+', 'X+', 'Y-', and 'X-'.
- Home (13):** Buttons for 'Home X' and 'Home Y Backward'.
- MODE (14):** Radio buttons for 'Linear', 'Circular', and 'Jog', along with a 'Step Size' input field.
- Speed (10):** Input fields for 'X' and 'Y' speeds.
- Motion status (15):** Input fields for 'X' and 'Y' motion status, with dropdown menus for 'Normal' and 'Normal stopped condition'.
- Command (11):** Input fields for 'X' and 'Y' commands, and a 'Clear Comm.' button.
- Play key (16):** 'Run' (blue square) and 'Stop' (red circle) buttons.
- Current Position (12):** Input fields for 'X' and 'Y' current positions, and a 'Clear Pos.' button.
- Next Card (17):** 'Next Card' and 'Save Config' buttons.
- Graph Range and Origin Position:** Bottom section with 'Clear', 'Center', 'XRang', 'YRang', 'X Org. Shift', 'Y Org. Shift', and 'Lock' options.

## 1. Jog Type:

- ▷ **Continuous Jog:** Pressing a directional button directs the axis to continuously accelerate, with releasing the button stopping the axis immediately.



- ▷ **Incremental Jog:** When one directional button is pressed, the axis steps the distance entered.



- 2. **Jog Setting:** Sets parameters for single axis motion. Inactive if "Jog Mode" is selected, since velocity and moving distance are decided by pulse input.
  - ▷ **Start Velocity:** Sets start velocity of motion in PPS.
  - ▷ **Maximum Velocity:** Sets the maximum velocity of motion in PPS.
  - ▷ **Tacc:** Sets the acceleration time in seconds.

3. **Operating Mode:** Selects operating mode.
  - ▷ **Absolute Mode:** “Position” is used as absolute target position for motion when “Linear Interpolation Mode” is selected. “ABS EndPos” and “ABS Center” are used as absolute target positions for motion when “Circular Interpolation Mode” is selected. The related functions are `_8154_start_ta_move()`, `_8154_start_sa_move()`.
  - ▷ **Relative Mode:** “Distance” is used as absolute target position for motion when “Linear Interpolation Mode” is selected. “Dis EndPos” and “Dis Center” are used as absolute target positions for motion when “Circular Interpolation Mode” is selected. The related function is `_8154_start_tr_move()`, `_8154_start_sr_move()`.
4. **DIR:** Specified direction of arc, CW/CCW, only effective when “Circular Interpolation Mode” is selected.
5. **Vel. Profile:** Selects velocity profile. Both Trapezoidal and S-Curve are available for “Linear Interpolation Mode” and “Circular Interpolation Mode”.
6. **Speed Parameters:** Sets the parameters for single axis motion. This parameter is meaningless if “Linear Interpolation Mode” or “Circular Interpolation Mode” is selected, since the velocity and moving distance is decided by pulse input.
  - ▷ **Start Velocity:** Sets the start velocity of motion in units of PPS.
  - ▷ **Maximum Velocity:** Sets the maximum velocity of motion in units of PPS.
  - ▷ **Accel. Time:** Sets acceleration time in seconds.
  - ▷ **Decel. Time:** Sets deceleration time in seconds.
  - ▷ **SVacc:** Sets S-curve range during acceleration in PPS.
  - ▷ **SVdec:** Sets the S-curve range during deceleration in PPS.

7. **Set Distance/End Pos:** Sets the absolute target positions or relative distance for “Linear Interpolation Mode” . Sets the position end of arc for “Circular Interpolation Mode”. Available for “Linear Interpolation Mode” and “Circular Interpolation Mode”.
8. **Set Center:** Sets the position of center for “Circular Interpolation Mode”. Only available when “Circular Interpolation Mode” is selected.
9. **Jog Command:** Pressing one directional button generates a move.

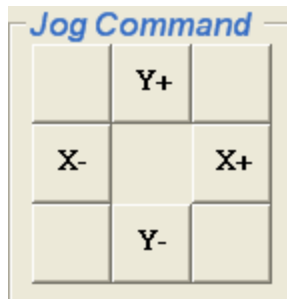

10. **Velocity:** The absolute value of velocity in PPS. The related function is `_8154_get_current_speed()`.
11. **Interpolation Command:**
  - ▷ **Command:** displays the value of the command counter. The related function is `_8154_get_command()`.
12. **Current Position:**
  - ▷ **Feedback:** displays the value of the feedback position counter. The related function is `_8154_get_position()`.
13. **Home Mode:** Home return motion. Clicking this button invokes the home move configuration window. The related function is `_8154_set_home_config()`. Two home return buttons in the lower left corner of the window return to the origin.

#### 14. Mode:

- ▷ **Linear Interpolation:** After motion parameters have been set in “Motion Parameters Setting Frame”, the destination can be entered in this frame. Run launches linear interpolation motion.
- ▷ **Circular Interpolation:** Circular interpolation mode has arc degree, division axis, and optimize option parameters in “Motion Parameters Setting Frame”.

After setting these parameters, arc center and degree can be entered in “Play Key Frame”. Run launches circular interpolation motion.

**15. Motion status:** Displays the returned value of the `_8154_motion_done` function. The related function is `_8154_motion_done()`.

#### 16. Play Key:

**Play button:** Causes the 8154 to outlet pulses according to previous settings.

- ▷ In “Linear Mode,” the axis moves to Distance. The related function is `_8154_start_tr_move_xy`, `_8154_start_sr_move_xy`.
- ▷ In “Circular Mode,” the axis moves to Distance(By Pos/ Dist(pulse)). The related function is `_8154_start_tr_arc_xy`, `_8154_start_sr_arc_xy`.

**Stop Button:** Causes the 8154 to decelerate and stop, with deceleration time is defined in “Decel. Time.” The related function is `_8154_sd_stop()`.

#### 17. Buttons:

- ▷ **Next Card:** Changes operating card.
- ▷ **Save Config:** Saves current configuration to 8154.ini And 8154MC.ini.
- ▷ **Close:** Closes the menu.





This page intentionally left blank.

## Appendix B Function Library Reference

The functions listed support development of programs in C, C++, and Visual Basic. If Delphi is used as the programming environment, it is necessary to transform the header files, `pci_8154.h` manually.

### B.1 Data Types

The library uses these data types in `pci_8154.h`. We suggest you use these data types in your application programs. Data type names and ranges in C/C++ are as follows

Type	Description	Range
U8	8-bit ASCII character	0 to 255
I16	16-bit signed integer	-32768 to 32767
U16	16-bit unsigned integer	0 to 65535
I32	32-bit signed long integer	-2147483648 to 2147483647
U32	32-bit unsigned long integer	0 to 4294967295
F32	32-bit single-precision floating-point	-3.402823E38 to 3.402823E38
F64	64-bit double-precision floating-point	-1.797683134862315E308 to 1.797683134862315E309
Boolean	Boolean logic value	TRUE, FALSE

### Function Naming

The PCIe-8154 software drivers use full names to identify the function. Naming conventions are as follows.

In a 'C' programming environment:

`_{hardware_model}_{action_name}`. e.g. `_8154_initial()`.

To differentiate between a C library and a VB library, a capital "B" is placed at the beginning of each function name e.g. `B_8154_initial()`.

## B.2 List of Functions

Category	Function
<b>System &amp; Initialization</b>	_8154_initial
	_8154_close
	_8154_get_version
	_8154_set_security_key
	_8154_check_security_key
	_8154_reset_security_key
	_8154_config_from_file
<b>Pulse Input/Output Configuration</b>	_8154_set_pls_outmode
	_8154_set_pls_ipmode
	_8154_set_feedback_src
<b>Velocity Mode Motion</b>	_8154_set_pls_outmode
	_8154_set_pls_ipmode
	_8154_set_feedback_src
	_8154_set_pls_outmode
	_8154_set_pls_ipmode
	_8154_set_feedback_src
	_8154_set_pls_outmode
<b>Single Axis Position Mode</b>	_8154_start_tr_move
	_8154_start_ta_move
	_8154_start_sr_move
	_8154_start_sa_move
	_8154_set_move_ratio
	_8154_position_override

Category	Function	
<b>Linear Interpolated Motion</b>	_8154_start_tr_move_xy	
	_8154_start_ta_move_xy	
	_8154_start_sr_move_xy	
	_8154_start_sa_move_xy	
	_8154_start_tr_move_zu	
	_8154_start_ta_move_zu	
	_8154_start_sr_move_zu	
	_8154_start_tr_line2	
	_8154_start_ta_line2	
	_8154_start_sr_line2	
	_8154_start_sa_line2	
	_8154_start_tr_line3	
	_8154_start_ta_line3	
	_8154_start_sr_line3	
	_8154_start_sa_line3	
	_8154_start_tr_line4	
	_8154_start_ta_line4	
	_8154_start_sr_line4	
	<b>Circular Interpolated Motion</b>	_8154_start_tr_arc_xy
		_8154_start_ta_arc_xy
_8154_start_sr_arc_xy		
_8154_start_sa_arc_xy		
_8154_start_tr_arc_zu		
_8154_start_ta_arc_zu		
_8154_start_sr_arc_zu		
_8154_start_sa_arc_zu		
_8154_start_tr_arc2		
_8154_start_ta_arc2		
_8154_start_sr_arc2		
_8154_start_sa_arc2		

Category	Function
<b>Helical Interpolation Motion</b>	_8154_start_tr_helical
	_8154_start_ta_helical
	_8154_start_sr_helical
	_8154_start_sa_helical
<b>Home Return Mode</b>	_8154_set_home_config
	_8154_home_move
	_8154_home_search
<b>Manual Pulse Generator Mode</b>	_8154_set_pulser iptmode
	_8154_disable_pulser_input
	_8154_pulser_vmove
	_8154_pulser_pmove
	_8154_set_pulser_ratio
<b>Motion Status, Section</b>	_8154_motion_done
<b>Motion Interface I/O</b>	_8154_set_servo
	_8154_set_pcs_logic
	_8154_set_pcs
	_8154_set_clr_mode
	_8154_set_inp
	_8154_set_alm
	_8154_set_erc
	_8154_set_erc_out
	_8154_clr_erc
	_8154_set_sd
	_8154_enable_sd
	_8154_set_limit_logic
	_8154_set_limit_mode
_8154_get_io_status	
<b>Interrupt Control</b>	_8154_int_control
	_8154_wait_error_interrupt
	_8154_wait_motion_interrupt
	_8154_set_motion_int_factor

Category	Function
<b>Position Control and Counters</b>	_8154_get_position
	_8154_set_position
	_8154_get_command
	_8154_set_command
	_8154_get_error_counter
	_8154_reset_error_counter
	_8154_get_general_counter
	_8154_set_general_counter
	_8154_get_target_pos
	_8154_reset_target_pos
	_8154_get_res_distance
	_8154_set_res_distance
	_8154_get_ring_counter
	_8154_set_ring_counter
	_8154_escape_home
<b>Position Compare and Latch</b>	_8154_set_trigger_logic
	_8154_set_error_comparator
	_8154_set_general_comparator
	_8154_set_trigger_comparator
	_8154_set_latch_source
	_8154_set_ltc_logic
<b>Continuous Motion</b>	_8154_get_latch_data
	_8154_set_continuous_move
	_8154_check_continuous_buffer
<b>Multi-Axis Simultaneous Operation</b>	_8154_dwell_move
	_8154_set_tr_move_all
	_8154_set_ta_move_all
	_8154_set_sr_move_all
	_8154_set_sa_move_all
	_8154_start_move_all
	_8154_stop_move_all

Category	Function
<b>General Purpose I/O</b>	_8154_set_gpio_output
	_8154_get_gpio_output
	_8154_get_gpio_input
	_8154_set_gpio_input_function
<b>Soft Limit</b>	_8154_disable_soft_limit
	_8154_enable_soft_limit
	_8154_set_soft_limit
<b>Backlash Compensation/ Vibration Suppression</b>	_8154_backlash_comp
	_8154_suppress_vibration
	_8154_set_fa_speed
<b>Speed Profile Calculation</b>	_8154_get_tr_move_profile
	_8154_get_ta_move_profile
	_8154_get_sr_move_profile
	_8154_get_sa_move_profile
<b>Extended General Purpose TTL Input/Output</b>	_8154_set_gpio_output_ex
	_8154_get_gpio_output_ex
	_8154_get_gpio_input_ex
	_8154_set_gpio_output_ex_CH
	_8154_get_gpio_output_ex_CH
	_8154_get_gpio_input_ex_CH

## B.3 System and Initialization

### @ Name

`_8154_initial` – Card initialization

`_8154_close` – Card close

`_8154_get_version` – Check hardware and software version information

`_8154_set_security_key` – Set the security password

`_8154_check_security_key` – Check the security password

`_8154_reset_security_key` – Rest the security password to default



`_8154_config_from_file` – Config PCIe-8154 settings from file

## @ Description

`_8154_initial`:

This function is used to initialize an 8154 card without assigning the hardware resources. All 8154 cards must be initialized by this function before calling other functions in your applications. By setting the parameter “**Manual\_ID**”, user can choose the type that the card’s ID is assigned manually or automatically.

`_8154_close`:

This function is used to close 8154 card and release its resources, which should be called at the end of your applications.

`_8154_get_version`:

Lets users read back the firmware’s, driver’s and DLL’s version information.

`_8154_set_security_key`:

This function is used to set a security code to the PCIe card.

See also:

`_8154_check_security_key`  
`_8154_reset_security_key`

`_8154_check_security_key`:

This function is used to verify the security code which the user set by the function “`_8154_set_security_key`”.

See also:

`_8154_set_security_key`  
`_8154_reset_security_key`

`_8154_reset_security_key`:

By this function, Users can reset the security code on the PCIe card to default value. The default security code is 0.

See also:

```
_8154_check_security_key  
_8154_set_security_key
```

### **\_8154\_config\_from\_file:**

This function is used to load the configuration of the PCIe-8154 according to specified file. By using MotionCreatorPro, user could test and configure the 8154 correctly. After saving the configuration, the file would be existed in user's system directory as 8154.ini.

When this function is executed, all 8154 cards in the system will be configured as the following functions were called according to parameters recorded in 8154.ini.

```
_8154_set_limit_logic  
_8154_set_pcs_logic  
_8154_set_ltc_logic  
_8154_set_inp  
_8154_set_erc  
_8154_set_alm  
_8154_set_pls_iptmode  
_8154_set_pls_outmode  
_8154_set_move_ratio  
_8154_set_latch_source  
_8154_set_feedback_src  
_8154_set_home_config  
_8154_set_soft_limit  
_8154_set_fa_speed  
_8154_set_sd
```

### **@ Syntax**

#### **C/C++(Windows XP/7/8.1)**

```
I16 _8154_initial(U16 *CardID_InBit, I16  
Manual_ID);  
I16 _8154_close(void);  
I16 _8154_get_version(I16 card_id, I16  
*firmware_ver, I32 *driver_ver, I32  
*dll_ver);  
I16 _8154_set_security_key(I16 card_id, I16  
old_secu_code, I16 new_secu_code);  
I16 _8154_check_security_key(I16 card_id, I16  
secu_code);  
I16 _8154_reset_security_key(I16 card_id);
```

```
I16 _8154_config_from_file();
```

### Visual Basic 6 (Windows XP/7/8.1)

```
B_8154_initial(CardID_InBit As Integer, ByVal
    Manual_ID As Integer) As Integer
B_8154_close() As Integer
B_8154_get_version(ByVal card_id As Integer,
    firmware_ver As Integer, driver_ver As Long,
    dll_ver As Long) As Integer
B_8154_set_security_key(ByVal card_id As Integer,
    ByVal old_secu_code As Integer, ByVal
    new_secu_code As Integer) As Integer
B_8154_check_security_key(ByVal card_id As
    Integer, ByVal secu_code As Integer)As
    Integer
B_8154_reset_security_key(ByVal card_id As
    Integer);
B_8154_config_from_file() As Integer
```

### @ Argument

**CardID\_InBit:**

**Manual\_ID:** Enable the On board dip switch (SW1) to decide the Card ID

The CardID could be decided by :

0: the sequence of PCIe slot.

1: on board DIP switch (SW1).

**card\_id:** Specify the PCIe-8154 card index. The card\_id could be decided by DIP switch (SW1) or depend on slot sequence. Please refer to `_8154_initial()`.

**firmware\_ver:** The current firmware version.

**driver\_ver:** The current device driver version.

**dll\_ver:** The current DLL library version.

**old\_secu\_code:** Old security code.

**new\_secu\_code:** New security code.

**secu\_code:** security code.

## B.4 Pulse Input/Output Configuration

### @ Name

`_8154_set_pls_iptmode` – Set the configuration for feedback pulse input.

`_8154_set_pls_outmode` – Set the configuration for pulse command output.

`_8154_set_feedback_src` – Enable/Disable the external feedback pulse input

### @ Description

`_8154_set_pls_iptmode`:

Configure the input modes of external feedback pulses. There are 4 types for feedback pulse input. Note that this function makes sense only when the Src parameter in `_8154_set_feedback_src()` function is enabled.

`_8154_set_pls_outmode`:

Configure the output modes of command pulses. There are 6 modes for command pulse output.

`_8154_set_feedback_src`:

If external encoder feedback is available in the system, set the Src parameter in this function to an **Enabled** state. Then, the internal 28-bit up/down counter will count according to the configuration of the `_8154_set_pls_iptmode()` function. Else, the counter will count the command pulse output.

### @ Syntax

#### C/C++(Windows XP/7/8.1)

```
I16 _8154_set_pls_iptmode(I16 AxisNo, I16  
    pls_iptmode, I16 pls_logic);  
I16 _8154_set_pls_outmode(I16 AxisNo, I16  
    pls_outmode);  
I16 _8154_set_feedback_src(I16 AxisNo, I16 Src);
```

## Visual Basic6 (Windows XP/7/8.1)

```

B_8154_set_pls_iptmode(ByVal AxisNo As Integer,
    ByVal pls_iptmode As Integer, ByVal
    pls_logic As Integer) As Integer
B_8154_set_pls_outmode(ByVal AxisNo As Integer,
    ByVal pls_outmode As Integer) As Integer
B_8154_set_feedback_src(ByVal AxisNo As Integer,
    ByVal Src As Integer) As Integer

```

### @ Argument

**AxisNo**: Axis number designated to configure the pulse input/output.

card_id	Physical axis	AxisNo
0	0	0
	1	1
	2	2
	3	3
1	0	4
	1	5
	...	...

**pls\_iptmode**: Encoder feedback pulse input mode setting (EA/EB signals).

Value	Meaning
0	1X A/B
1	2X A/B
2	4X A/B
3	CW/CCW

**pls\_logic**: Logic of encoder feedback pulse.

Value	Meaning
0	Not inverse direction
1	inverse direction

**pls\_outmode**: Setting of command pulse output mode.

Value	Type	Positive Direction				Negative Direction			
0	OUT/DIR								
1	OUT/DIR								
2	OUT/DIR								
3	OUT/DIR								
4	CW / CCW								
5	CW / CCW								
6	AB	OUT DIR				OUT DIR			
7	AB	OUT DIR				OUT DIR			

**src**: Counter source

Value	Meaning
0	External signal feedback
1	Command pulse

## B.5 Velocity mode motion

### @ Name

**\_8154\_tv\_move** – Accelerate an axis to a constant velocity with trapezoidal profile

**\_8154\_sv\_move** – Accelerate an axis to a constant velocity with S-curve profile

**\_8154\_emg\_stop** – Immediately stop

**\_8154\_sd\_stop** – Decelerate to stop

**\_8154\_get\_current\_speed** – Get current speed

**\_8154\_speed\_override** – Change speed on the fly

**@ Description****\_8154\_tv\_move:**

This function is to accelerate an axis to the specified constant velocity with a trapezoidal profile. The axis will continue to travel at a constant velocity until the velocity is changed or the axis is commanded to stop. The direction is determined by the sign of the velocity parameter.

**\_8154\_sv\_move:**

This function is to accelerate an axis to the specified constant velocity with a S-curve profile. The axis will continue to travel at a constant velocity until the velocity is changed or the axis is commanded to stop. The direction is determined by the sign of velocity parameter.

**\_8154\_emg\_stop:**

This function is used to immediately stop an axis. This function is also useful when a preset move (both trapezoidal and S-curve motion), manual move, or home return function is performed.

**\_8154\_sd\_stop:**

This function is used to decelerate an axis to stop with a trapezoidal or S-curve profile. This function is also useful when a preset move (both trapezoidal and S-curve motion), manual move, or home return function is performed. Note: The velocity profile is decided by original motion profile.

**\_8154\_get\_current\_speed:**

This function is used to read the current pulse output rate (pulse/sec) of a specified axis. It is applicable in any time in any operating mode.

**@ Syntax****C/C++(Windows XP/7/8.1)**

```
I16 _8154_tv_move(I16 AxisNo, F64 StrVel, F64
    MaxVel, F64 Tacc);
I16 _8154_sv_move(I16 AxisNo, F64 StrVel, F64
    MaxVel, F64 Tacc, F64 SVacc);
```

```
I16 _8154_emg_stop(I16 AxisNo);
I16 _8154_sd_stop(I16 AxisNo, F64 Tdec);
I16 _8154_get_current_speed(I16 AxisNo, F64
    *speed)
```

### Visual Basic6 (Windows XP/7/8.1)

```
B_8154_tv_move(ByVal AxisNo As Integer, ByVal
    StrVel As Double, ByVal MaxVel As Double,
    ByVal Tacc As Double) As Integer
B_8154_sv_move(ByVal AxisNo As Integer, ByVal
    StrVel As Double, ByVal MaxVel As Double,
    ByVal Tacc As Double, ByVal SVacc As Double)
    As Integer
B_8154_emg_stop(ByVal AxisNo As Integer) As
    Integer
B_8154_sd_stop(ByVal AxisNo As Integer, ByVal
    Tdec As Double) As Integer
B_8154_get_current_speed(ByVal AxisNo As Integer,
    ByRef Speed As Double) As Integer
```

### @ Argument

**AxisNo:** Axis number designated to move or stop.

card_id	Physical axis	AxisNo
0	0	0
	1	1
	2	2
	3	3
1	0	4
	1	5
	...	...

**strVel:** Starting velocity in units of pulse per second

**MaxVel:** Maximum velocity in units of pulse per second

**Tacc:** Specified acceleration time in units of second

**SVacc:** Specified velocity interval in which S-curve acceleration is performed.

Note: SVacc = 0, for pure S-Curve

**Tdec:** specified deceleration time in units of second



\***speed**: Variable to get current speed (pulse/sec).

## B.6 Single Axis Position Mode

### @ Name

`_8154_start_tr_move` – Begin a relative trapezoidal profile move

`_8154_start_ta_move` – Begins absolute trapezoidal profile move

`_8154_start_sr_move` – Begin a relative S-curve profile move

`_8154_start_sa_move` – Begins absolute S-curve profile move

`_8154_set_move_ratio` – Set the ration of command pulse and feedback pulse

`_8154_position_override` – Change position on the fly

`_8154_set_max_override_speed` – Set the maximum override speed

### @ Description

#### General:

The moving direction is determined by the sign of the Pos or Dist parameter. If the moving distance is too short to reach the specified velocity, the controller will automatically lower the **MaxVel**, and the **Tacc**, **Tdec**, **VSacc**, and **VSdec** will also become shorter while  $dV/dt$ (acceleration / deceleration) and  $d(dV/dt)/dt$  (jerk) are keep unchanged.

#### `_8154_start_tr_move`:

This function causes the axis to accelerate from a starting velocity (**StrVel**), rotate at constant velocity (**MaxVel**), and decelerate to stop at the **relative distance** with **trapezoidal** profile. The acceleration (**Tacc**) and deceleration (**Tdec**) time is specified independently—it does not let the program wait for motion completion but immediately returns control to the program.

#### \_8154\_start\_ta\_move:

This function causes the axis to accelerate from a starting velocity (StrVel), rotate at constant velocity (MaxVel), and decelerates to stop at the specified **absolute position** with **trapezoidal** profile. The acceleration (Tacc) and deceleration (Tdec) time is specified independently. This command does not let the program wait for motion completion, but immediately returns control to the program.

#### \_8154\_start\_sr\_move:

This function causes the axis to accelerate from a starting velocity (StrVel), rotate at constant velocity (MaxVel), and decelerates to stop at the **relative distance** with **S-curve** profile. The acceleration (Tacc) and deceleration (Tdec) time is specified independently. This command does not let the program wait for motion completion, but immediately returns control to the program.

#### \_8154\_start\_sa\_move:

This function causes the axis to accelerate from a starting velocity (StrVel), rotate at constant velocity, and decelerates to stop at the specified **absolute position** with **S-curve** profile. The acceleration and deceleration time is specified independently. This command does not let the program wait for motion completion but immediately returns control to the program.

#### \_8154\_set\_move\_ratio:

This function configures scale factors for the specified axis. Usually, the axes only need scale factors if their mechanical resolutions are different. For example, if the resolution of feedback sensors is two times resolution of command pulse, then the parameter “**move\_ratio**” could be set as 2.

#### \_8154\_position\_override:

This function is used to change target position on the fly. There are some limitations on this function. Please refer to section 4.2.15 before use it.

#### \_8154\_set\_max\_override\_speed:

**@ Syntax****C/C++(Windows XP/7/8.1)**

```

I16 _8154_start_tr_move(I16 AxisNo, F64 Dist, F64
    StrVel, F64 MaxVel, F64 Tacc, F64 Tdec);
I16 _8154_start_ta_move(I16 AxisNo, F64 Pos, F64
    StrVel, F64 MaxVel, F64 Tacc, F64 Tdec);
I16 _8154_start_sr_move(I16 AxisNo, F64 Dist, F64
    StrVel, F64 MaxVel, F64 Tacc, F64 Tdec, F64
    SVacc, F64 SVdec);
I16 _8154_start_sa_move(I16 AxisNo, F64 Pos, F64
    StrVel, F64 MaxVel, F64 Tacc, F64 Tdec, F64
    SVacc, F64 SVdec);
I16 _8154_set_move_ratio(I16 AxisNo, F64
    move_ratio);
I16 _8154_position_override(I16 AxisNo, F64
    NewPos);
I16 _8154_set_max_override_speed(I16 AxisNo, F64
    OvrSpeed, I16 Enable);

```

**Visual Basic6 (Windows XP/7/8.1)**

```

B_8154_start_tr_move(ByVal AxisNo As Integer,
    ByVal Dist As Double, ByVal StrVel As
    Double, ByVal MaxVel As Double, ByVal Tacc
    As Double, ByVal Tdec As Double) As Integer
B_8154_start_ta_move(ByVal AxisNo As Integer,
    ByVal Pos As Double, ByVal StrVel As Double,
    ByVal MaxVel As Double, ByVal Tacc As
    Double, ByVal Tdec As Double) As Integer
B_8154_start_sr_move(ByVal AxisNo As Integer,
    ByVal Dist As Double, ByVal StrVel As
    Double, ByVal MaxVel As Double, ByVal Tacc
    As Double, ByVal Tdec As Double, ByVal SVacc
    As Double, ByVal SVdec As Double) As Integer
B_8154_start_sa_move(ByVal AxisNo As Integer,
    ByVal Pos As Double, ByVal StrVel As Double,
    ByVal MaxVel As Double, ByVal Tacc As
    Double, ByVal Tdec As Double, ByVal SVacc As
    Double, ByVal SVdec As Double) As Integer
B_8154_set_move_ratio(ByVal AxisNo As Integer,
    ByVal move_ratio As Double) As Integer
B_8154_position_override(ByVal AxisNo As Integer,
    ByVal NewPos As Double) As Integer

```

```
B_8154_set_max_override_speed(ByVal AxisNo As Integer, ByVal OvrSpeed As Double, ByVal Enable As Integer) As Integer
```

## @ Argument

**AxisNo:** Axis number designated to move or stop.

card_id	Physical axis	AxisNo
0	0	0
	1	1
	2	2
	3	3
1	0	4
	1	5
	...	...

**Dist:** Specified relative distance to move (unit: pulse)

**Pos:** Specified absolute position to move (unit: pulse)

**StrVel:** Starting velocity of a velocity profile in units of pulse per second

**MaxVel:** Maximum velocity in units of pulse per second

**Tacc:** Specified acceleration time in units of seconds

**Tdec:** Specified deceleration time in units of seconds

**SVacc:** Specified velocity interval in which S-curve acceleration is performed.

Note: SVacc = 0, for pure S-Curve. For more details, see section 2.4.4

**SVdec:** specified velocity interval in which S-curve deceleration is performed.

Note: SVdec = 0, for pure S-Curve. For more details, see section 4.2.4

**Move\_ratio:** ratio of (feedback resolution)/(command resolution), should not be 0

**NewPos:** specified new absolute position to move

## B.7 Linear Interpolated Motion

### @ Name

`_8154_start_tr_move_xy` – Begin a relative 2-axis linear interpolation for X & Y axis with trapezoidal profile

`_8154_start_ta_move_xy` – Begins absolute 2-axis linear interpolation for X & Y axis with trapezoidal profile

`_8154_start_sr_move_xy` –Begin a relative 2-axis linear interpolation for X & Y axis with S-curve profile

`_8154_start_sa_move_xy` –Begins absolute 2-axis linear interpolation for X & Y axis with S-curve profile

`_8154_start_tr_move_zu` – Begin a relative 2-axis linear interpolation for Z & U axis with trapezoidal profile

`_8154_start_ta_move_zu` – Begins absolute 2-axis linear interpolation for Z & U axis with trapezoidal profile

`_8154_start_sr_move_zu` –Begin a relative 2-axis linear interpolation for Z & U axis with S-curve profile

`_8154_start_sa_move_zu` –Begins absolute 2-axis linear interpolation for Z & U axis with S-curve profile

`_8154_start_ta_line2` – Begins absolute 2-axis linear interpolation for any 2 of 4 axes, with trapezoidal profile

`_8154_start_sr_line2` – Begin a relative 2-axis linear interpolation for any 2 of 4 axes, with S-curve profile

`_8154_start_sa_line2` – Begins absolute 2-axis linear interpolation for any 2 of 4 axes, with S-curve profile

`_8154_start_tr_line3` – Begin a relative 3-axis linear interpolation for any 3 of 4 axes, with trapezoidal profile

`_8154_start_ta_line3` – Begin a absolute 3-axis linear interpolation for any 3 of 4 axes, with trapezoidal profile

`_8154_start_sr_line3` – Begin a relative 3-axis linear interpolation for any 3 of 4 axes, with S-curve profile

`_8154_start_sa_line3` – Begin a absolute 3-axis linear interpolation for any 3 of 4 axes, with S-curve profile

**\_8154\_start\_tr\_line4** – Begin a relative 4-axis linear interpolation for any 4 of 4 axes, with trapezoidal profile

**\_8154\_start\_ta\_line4** – Begin a absolute 4-axis linear interpolation for any 4 of 4 axes, with trapezoidal profile

**\_8154\_start\_sr\_line4** – Begin a relative 4-axis linear interpolation for any 4 of 4 axes, with S-curve profile

**\_8154\_start\_sa\_line4** – Begin a absolute 4-axis linear interpolation for any 4 of 4 axes, with S-curve profile

## @ Description

These functions perform linear interpolation motion with different profile. Detail Comparisons of those functions are described by follow table.

Function	Total axes	Velocity Profile	Relative Absolute	Target Axes
_8154_start_tr_move_xy	2	T	R	Axes 0 & 1
_8154_start_ta_move_xy	2	T	A	Axes 0 & 1
_8154_start_sr_move_xy	2	S	R	Axes 0 & 1
_8154_start_sa_move_xy	2	S	A	Axes 0 & 1
_8154_start_tr_move_zu	2	T	R	Axes 2 & 3
_8154_start_ta_move_zu	2	T	A	Axes 2 & 3
_8154_start_sr_move_zu	2	S	R	Axes 2 & 3
_8154_start_sa_move_zu	2	S	A	Axes 2 & 3

Function	Total axes	Velocity Profile	Relative Absolute	Target Axes
_8154_start_tr_line2	2	T	R	Any 2 of 4 axes
_8154_start_ta_line2	2	T	A	Any 2 of 4 axes
_8154_start_sr_line2	2	S	R	Any 2 of 4 axes
_8154_start_sa_line2	2	S	A	Any 2 of 4 axes

Note: The target two axes of linear interpolation are the 2 of 4 axes on a card.

Function	Total axes	Velocity Profile	Relative Absolute	Target Axes
_8154_start_tr_line3	3	T	R	Any 3 of 4 axes
_8154_start_ta_line3	3	T	A	Any 3 of 4 axes
_8154_start_sr_line3	3	S	R	Any 3 of 4 axes
_8154_start_sa_line3	3	S	A	Any 3 of 4 axes

Note: The target 3 axes of linear interpolation are the 3 of 4 axes on a card.

Function	Total axes	Velocity Profile	Relative Absolute	Target Axes
_8154_start_tr_line4	4	T	R	Any 4 of 4 axes
_8154_start_ta_line4	4	T	A	Any 4 of 4 axes
_8154_start_sr_line4	4	S	R	Any 4 of 4 axes
_8154_start_sa_line4	4	S	A	Any 4 of 4 axes

Note: The target 4 axes of linear interpolation are the 4 of 4 axes on a card.

### Velocity profile:

T: trapezoidal profile

S: S-curve profile

### Relative / Absolute:

R: Relative distance

A: Absolute position

### @ Syntax

#### C/C++(Windows XP/7/8.1)

```
I16 _8154_start_tr_move_xy(I16 Card_id, F64
    DistX, F64 DistY, F64 StrVel, F64 MaxVel,
    F64 Tacc, F64 Tdec);
I16 _8154_start_ta_move_xy(I16 Card_id, F64 PosX,
    F64 PosY, F64 StrVel, F64 MaxVel, F64 Tacc,
    F64 Tdec);
```

```
I16 _8154_start_sr_move_xy(I16 Card_id, F64
    DistX, F64 DistY, F64 StrVel, F64 MaxVel,
    F64 Tacc, F64 Tdec, F64 SVacc, F64 SVdec);
I16 _8154_start_sa_move_xy(I16 Card_id, F64 PosX,
    F64 PosY, F64 StrVel, F64 MaxVel, F64 Tacc,
    F64 Tdec, F64 SVacc, F64 SVdec);
I16 _8154_start_tr_move_zu(I16 Card_id, F64
    DistX, F64 DistY, F64 StrVel, F64 MaxVel,
    F64 Tacc, F64 Tdec);
I16 _8154_start_ta_move_zu(I16 Card_id, F64 PosX,
    F64 PosY, F64 StrVel, F64 MaxVel, F64 Tacc,
    F64 Tdec);
I16 _8154_start_sr_move_zu(I16 Card_id, F64
    DistX, F64 DistY, F64 StrVel, F64 MaxVel,
    F64 Tacc, F64 Tdec, F64 SVacc, F64 SVdec);
I16 _8154_start_sa_move_zu(I16 Card_id, F64 PosX,
    F64 PosY, F64 StrVel, F64 MaxVel, F64 Tacc,
    F64 Tdec, F64 SVacc, F64 SVdec);
I16 _8154_start_tr_line2(I16 *AxisArray, F64
    *DistArray, F64 StrVel, F64 MaxVel, F64
    Tacc, F64 Tdec);
I16 _8154_start_ta_line2(I16 *AxisArray, F64
    *PosArray, F64 StrVel, F64 MaxVel, F64 Tacc,
    F64 Tdec);
I16 _8154_start_sr_line2(I16 *AxisArray, F64
    *DistArray, F64 StrVel, F64 MaxVel, F64
    Tacc, F64 Tdec, F64 SVacc, F64 SVdec);
I16 _8154_start_sa_line2(I16 *AxisArray, F64
    *PosArray, F64 StrVel, F64 MaxVel, F64 Tacc,
    F64 Tdec, F64 SVacc, F64 SVdec);
I16 _8154_start_tr_line3(I16 *AxisArray, F64
    *DistArray, F64 StrVel, F64 MaxVel, F64
    Tacc, F64 Tdec);
I16 _8154_start_ta_line3(I16 *AxisArray, F64
    *PosArray, F64 StrVel, F64 MaxVel, F64 Tacc,
    F64 Tdec);
I16 _8154_start_sr_line3(I16 *AxisArray, F64
    *DistArray, F64 StrVel, F64 MaxVel, F64
    Tacc, F64 Tdec, F64 SVacc, F64 SVdec);
I16 _8154_start_sa_line3(I16 *AxisArray, F64
    *PosArray, F64 StrVel, F64 MaxVel, F64 Tacc,
    F64 Tdec, F64 SVacc, F64 SVdec);
```



```

I16 _8154_start_tr_line4(I16 *AxisArray, F64
    *DistArray, F64 StrVel, F64 MaxVel, F64
    Tacc, F64 Tdec);
I16 _8154_start_ta_line4(I16 *AxisArray, F64
    *PosArray, F64 StrVel, F64 MaxVel, F64 Tacc,
    F64 Tdec);
I16 _8154_start_sr_line4(I16 *AxisArray, F64
    *DistArray, F64 StrVel, F64 MaxVel, F64
    Tacc, F64 Tdec, F64 SVacc, F64 SVdec);
I16 _8154_start_sa_line4(I16 *AxisArray, F64
    *PosArray, F64 StrVel, F64 MaxVel, F64 Tacc,
    F64 Tdec, F64 SVacc, F64 SVdec);

```

### Visual Basic6 (Windows XP/7/8.1)

```

B_8154_start_tr_move_xy(ByVal Card_id As Integer,
    ByVal DistX As Double, ByVal DistY As
    Double, ByVal StrVel As Double, ByVal MaxVel
    As Double, ByVal Tacc As Double, ByVal Tdec
    As Double) As Integer
B_8154_start_ta_move_xy(ByVal Card_id As Integer,
    ByVal PosX As Double, ByVal PosY As Double,
    ByVal StrVel As Double, ByVal MaxVel As
    Double, ByVal Tacc As Double, ByVal Tdec As
    Double) As Integer
B_8154_start_sr_move_xy(ByVal Card_id As Integer,
    ByVal DistX As Double, ByVal DistY As
    Double, ByVal StrVel As Double, ByVal MaxVel
    As Double, ByVal Tacc As Double, ByVal Tdec
    As Double, ByVal SVacc As Double, ByVal
    SVdec As Double) As Integer
B_8154_start_sa_move_xy(ByVal Card_id As Integer,
    ByVal PosX As Double, ByVal PosY As Double,
    ByVal StrVel As Double, ByVal MaxVel As
    Double, ByVal Tacc As Double, ByVal Tdec As
    Double, ByVal SVacc As Double, ByVal SVdec
    As Double) As Integer
B_8154_start_tr_move_zu(ByVal Card_id As Integer,
    ByVal DistX As Double, ByVal DistY As
    Double, ByVal StrVel As Double, ByVal MaxVel
    As Double, ByVal Tacc As Double, ByVal Tdec
    As Double);
B_8154_start_ta_move_zu(ByVal Card_id As Integer,
    ByVal PosX As Double, ByVal PosY As Double,
    ByVal StrVel As Double, ByVal MaxVel As

```

```
Double, ByVal Tacc As Double, ByVal Tdec As
Double) As Integer
B_8154_start_sr_move_zu(ByVal Card_id As Integer,
ByVal DistX As Double, ByVal DistY As
Double, ByVal StrVel As Double, ByVal MaxVel
As Double, ByVal Tacc As Double, ByVal Tdec
As Double, ByVal SVacc As Double, ByVal
SVdec As Double) As Integer
B_8154_start_sa_move_zu(ByVal Card_id As Integer,
ByVal PosX As Double, ByVal PosY As Double,
ByVal StrVel As Double, ByVal MaxVel As
Double, ByVal Tacc As Double, ByVal Tdec As
Double, ByVal SVacc As Double, ByVal SVdec
As Double) As Integer
B_8154_start_tr_line2(AxisArray() As Integer,
DistArray() As Double, ByVal StrVel As
Double, ByVal MaxVel As Double, ByVal Tacc
As Double, ByVal Tdec As Double) As Integer
B_8154_start_ta_line2(AxisArray() As Integer,
PosArray() As Double, ByVal StrVel As
Double, ByVal MaxVel As Double, ByVal Tacc
As Double, ByVal Tdec As Double) As Integer
B_8154_start_sr_line2((AxisArray() As Integer,
DistArray() As Double, ByVal StrVel As
Double, ByVal MaxVel As Double, ByVal Tacc
As Double, ByVal Tdec As Double, ByVal Svacc
As Double, ByVal Svdec As Double) As Integer
B_8154_start_sa_line2(AxisArray() As Integer,
PosArray() As Double, ByVal StrVel As
Double, ByVal MaxVel As Double, ByVal Tacc
As Double, ByVal Tdec As Double, ByVal Svacc
As Double, ByVal Svdec As Double) As Integer
B_8154_start_tr_line3(AxisArray() As Integer,
DistArray() As Double, ByVal StrVel As
Double, ByVal MaxVel As Double, ByVal Tacc
As Double, ByVal Tdec As Double) As Integer
B_8154_start_ta_line3(AxisArray() As Integer,
PosArray() As Double, ByVal StrVel As
Double, ByVal MaxVel As Double, ByVal Tacc
As Double, ByVal Tdec As Double) As Integer
B_8154_start_sr_line3((AxisArray() As Integer,
DistArray() As Double, ByVal StrVel As
Double, ByVal MaxVel As Double, ByVal Tacc
```

```

As Double, ByVal Tdec As Double, ByVal Svacc
As Double, ByVal Svdec As Double) As Integer
B_8154_start_sa_line3(AxisArray() As Integer,
PosArray() As Double, ByVal StrVel As
Double, ByVal MaxVel As Double, ByVal Tacc
As Double, ByVal Tdec As Double, ByVal Svacc
As Double, ByVal Svdec As Double) As Integer
B_8154_start_tr_line4(AxisArray() As Integer,
DistArray() As Double, ByVal StrVel As
Double, ByVal MaxVel As Double, ByVal Tacc
As Double, ByVal Tdec As Double) As Integer
B_8154_start_ta_line4(AxisArray() As Integer,
PosArray() As Double, ByVal StrVel As
Double, ByVal MaxVel As Double, ByVal Tacc
As Double, ByVal Tdec As Double) As Integer
B_8154_start_sr_line4((AxisArray() As Integer,
DistArray() As Double, ByVal StrVel As
Double, ByVal MaxVel As Double, ByVal Tacc
As Double, ByVal Tdec As Double, ByVal Svacc
As Double, ByVal Svdec As Double) As Integer
B_8154_start_sa_line4(AxisArray() As Integer,
PosArray() As Double, ByVal StrVel As
Double, ByVal MaxVel As Double, ByVal Tacc
As Double, ByVal Tdec As Double, ByVal Svacc
As Double, ByVal Svdec As Double) As Integer

```

**@ Argument**

**card\_id:** Specify the PCIe-8154 card index. The card\_id could be decided by DIP switch (SW1) or depend on slot sequence. Please refer to `_8154_initial()`.

**AxisNo:** Axis number designated to move or stop.

card_id	Physical axis	AxisNo
0	0	0
	1	1
	2	2
	3	3
1	0	4
	1	5
	...	...

**DistX**: specified relative distance of **axis 0** to move (unit: pulse).  
**DistY**: specified relative distance of **axis 1** to move (unit: pulse).  
**PosX**: specified absolute position of **axis 0** to move (unit: pulse).  
**PosY**: specified absolute position of **axis 1** to move (unit: pulse).  
**strVel**: Starting velocity of a velocity profile in units of pulse per second.  
**MaxVel**: Maximum velocity in units of pulse per second.  
**Tacc**: Specified acceleration time in units of seconds.  
**Tdec**: Specified deceleration time in units of seconds.  
**SVacc**: Specified velocity interval in which S-curve acceleration is performed.

Note: SVacc = 0, for pure S-Curve. For more details, see section 4.2.4

**SVdec**: specified velocity interval in which S-curve deceleration is performed.

Note: SVdec = 0, for pure S-Curve. For more details, see section 4.2.4

**\*AxisArray**: Array of axis number to perform interpolation.

Example:

```
I16 AxisArray[2] = {0, 3}; //axis 0, & axis 3  
    (correct)  
I16 AxisArray[3] = {0,2, 3}; //axis 0, 2 & 3  
    (correct)  
I16 AxisArray[2] = {1, 6}; //axis 1, & axis 6  
    (incorrect)
```

**\*DistArray**: Array of relative distance for linear interpolation.

Example:

```
I16 AxisArray[2] = {0, 3}; //axis 0, & axis 3  
F64 DistArray[2] = {1000.0, 2000.0} //for axis 0  
    & 3
```

**\*PosArray**: Array of absolute position for linear interpolation.

Example:

```
I16 AxisArray[3] = {0,2, 3}; //axis 0, 2 & 3
F64 PosArray[3] = {200.0, 300.0, 400.0} //
      absolute position for axis 0, 2 & 3
```

## B.8 Circular Interpolation Motion

### @ Name

\_8154\_start\_tr\_arc\_xy – Begin a T-curve relative circular interpolation for X & Y axis

\_8154\_start\_ta\_arc\_xy – Begin a T-curve absolute circular interpolation for X & Y axis

\_8154\_start\_sr\_arc\_xy – Begin a S-curve relative circular interpolation for X & Y axis

\_8154\_start\_sa\_arc\_xy –Begin a S-curve absolute circular interpolation for X & Y axis

\_8154\_start\_tr\_arc\_zu – Begin a T-curve relative circular interpolation for Z & U axis

\_8154\_start\_ta\_arc\_zu – Begin a T-curve absolute circular interpolation for Z & U axis

\_8154\_start\_sr\_arc\_zu – Begin a S-curve relative circular interpolation for Z & U axis

\_8154\_start\_sa\_arc\_zu –Begin a S-curve absolute circular interpolation for Z & U axis

\_8154\_start\_tr\_arc2 – Begin a T-curve relative circular interpolation for any 2 of 4 axes

\_8154\_start\_ta\_arc2 – Begin a T-curve absolute circular interpolation for any 2 of 4 axes

\_8154\_start\_sr\_arc2 – Begin a S-curve relative circular interpolation for any 2 of 4 axes

\_8154\_start\_sa\_arc2 – Begin a S-curve absolute circular interpolation for any 2 of 4 axes

## @ Description

Those functions perform Circular interpolation motion with different profile. Detail Comparisons of those functions are described by follow table.

Function	Total axes	Velocity Profile	Relative Absolute	Target Axes
<code>_8154_start_tr_arc_xy</code>	2	trapezoidal	R	Axes 0 & 1
<code>_8154_start_ta_arc_xy</code>	2	trapezoidal	A	Axes 0 & 1
<code>_8154_start_sr_arc_xy</code>	2	S-curve	R	Axes 0 & 1
<code>_8154_start_sa_arc_xy</code>	2	S-curve	A	Axes 0 & 1
<code>_8154_start_tr_arc_zu</code>	2	trapezoidal	R	Axes 2 & 3
<code>_8154_start_ta_arc_zu</code>	2	trapezoidal	A	Axes 2 & 3
<code>_8154_start_sr_arc_zu</code>	2	S-curve	R	Axes 2 & 3
<code>_8154_start_sa_arc_zu</code>	2	S-curve	A	Axes 2 & 3
<code>_8154_start_tr_arc2</code>	2	trapezoidal	R	Any 2 of 4 Axis
<code>_8154_start_ta_arc2</code>	2	trapezoidal	A	Any 2 of 4 Axis
<code>_8154_start_sr_arc2</code>	2	S-curve	R	Any 2 of 4 Axis
<code>_8154_start_sa_arc2</code>	2	S-curve	A	Any 2 of 4 Axis

## @ Syntax

### C/C++(Windows XP/7/8.1)

```

I16 _8154_start_tr_arc_xy(I16 card_id, F64
    OffsetCx, F64 OffsetCy, F64 OffsetEx, F64
    OffsetEy, I16 CW_CCW, F64 StrVel, F64
    MaxVel, F64 Tacc, F64 Tdec);
I16 _8154_start_ta_arc_xy(I16 card_id, F64 Cx,
    F64 Cy, F64 Ex, F64 Ey, I16 CW_CCW, F64
    StrVel, F64 MaxVel, F64 Tacc, F64 Tdec);
I16 _8154_start_sr_arc_xy(I16 card_id, F64
    OffsetCx, F64 OffsetCy, F64 OffsetEx, F64
    OffsetEy, I16 CW_CCW, F64 StrVel, F64
    MaxVel, F64 Tacc, F64 Tdec, F64 SVacc, F64
    SVdec);
I16 _8154_start_sa_arc_xy(I16 card_id, F64 Cx,
    F64 Cy, F64 Ex, F64 Ey, I16 CW_CCW, F64
    StrVel, F64 MaxVel, F64 Tacc, F64 Tdec, F64
    SVacc, F64 SVdec);
  
```

```

I16 _8154_start_tr_arc_zu(I16 card_id, F64
    OffsetCx, F64 OffsetCy, F64 OffsetEx, F64
    OffsetEy, I16 CW_CCW, F64 StrVel,F64
    MaxVel,F64 Tacc,F64 Tdec);
I16 _8154_start_ta_arc_zu(I16 card_id, F64 Cx,
    F64 Cy, F64 Ex, F64 Ey, I16 CW_CCW, F64
    StrVel,F64 MaxVel,F64 Tacc,F64 Tdec);
I16 _8154_start_sr_arc_zu(I16 card_id, F64
    OffsetCx, F64 OffsetCy, F64 OffsetEx, F64
    OffsetEy, I16 CW_CCW, F64 StrVel,F64
    MaxVel,F64 Tacc,F64 Tdec,F64 SVacc,F64
    SVdec);
I16 _8154_start_sa_arc_zu(I16 card_id, F64 Cx,
    F64 Cy, F64 Ex, F64 Ey, I16 CW_CCW, F64
    StrVel,F64 MaxVel,F64 Tacc,F64 Tdec,F64
    SVacc,F64 SVdec);
I16 _8154_start_tr_arc2(I16 *AxisArray, F64
    *OffsetCenter, F64 *OffsetEnd, I16 CW_CCW,
    F64 StrVel,F64 MaxVel,F64 Tacc,F64 Tdec);
I16 _8154_start_ta_arc2(I16 *AxisArray, F64
    *CenterPos, F64 *EndPos, I16 CW_CCW, F64
    StrVel,F64 MaxVel,F64 Tacc,F64 Tdec);
I16 _8154_start_sr_arc2(I16 *AxisArray, F64
    *OffsetCenter, F64 *OffsetEnd, I16 CW_CCW,
    F64 StrVel,F64 MaxVel,F64 Tacc,F64 Tdec, F64
    SVacc,F64 SVdec);
I16 _8154_start_sa_arc2(I16 *AxisArray, F64
    *CenterPos, F64 *EndPos, I16 CW_CCW, F64
    StrVel,F64 MaxVel, F64 Tacc, F64 Tdec, F64
    SVacc, F64 SVdec);

```

### Visual Basic6 (Windows XP/7/8.1)

```

B_8154_start_tr_arc_xy( ByVal card_id As Integer,
    ByVal OffsetCx As Double, ByVal OffsetCy As
    Double, ByVal OffsetEx As Double, ByVal
    OffsetEy As Double, ByVal CW_CCW As Integer,
    ByVal StrVel As Double, ByVal MaxVel As
    Double, ByVal Tacc As Double, ByVal Tdec As
    Double);
B_8154_start_ta_arc_xy(ByVal card_id As Integer,
    ByVal Cx As Double, ByVal Cy As Double,
    ByVal Ex As Double, ByVal Ey As Double,
    ByVal CW_CCW As Integer, ByVal StrVel As

```

```
Double, ByVal MaxVel As Double, ByVal Tacc
As Double, ByVal Tdec As Double) As Integer
B_8154_start_sr_arc_xy(ByVal card_id As Integer,
ByVal OffsetCx As Double, ByVal OffsetCy As
Double, ByVal OffsetEx As Double, ByVal
OffsetEy As Double, ByVal CW_CCW As Integer,
ByVal StrVel As Double, ByVal MaxVel As
Double, ByVal Tacc As Double, ByVal Tdec As
Double, ByVal Svacc As Double, ByVal Svdec
As Double) As Integer
B_8154_start_sa_arc_xy(ByVal card_id As Integer,
ByVal Cx As Double, ByVal Cy As Double,
ByVal Ex As Double, ByVal Ey As Double,
ByVal CW_CCW As Integer, ByVal StrVel As
Double, ByVal MaxVel As Double, ByVal Tacc
As Double, ByVal Tdec As Double, ByVal Svacc
As Double, ByVal Svdec As Double) As Integer
B_8154_start_tr_arc_zu( ByVal card_id As Integer,
ByVal OffsetCx As Double, ByVal OffsetCy As
Double, ByVal OffsetEx As Double, ByVal
OffsetEy As Double, ByVal CW_CCW As Integer,
ByVal StrVel As Double, ByVal MaxVel As
Double, ByVal Tacc As Double, ByVal Tdec As
Double);
B_8154_start_ta_arc_zu(ByVal card_id As Integer,
ByVal Cx As Double, ByVal Cy As Double,
ByVal Ex As Double, ByVal Ey As Double,
ByVal CW_CCW As Integer, ByVal StrVel As
Double, ByVal MaxVel As Double, ByVal Tacc
As Double, ByVal Tdec As Double) As Integer
B_8154_start_sr_arc_zu(ByVal card_id As Integer,
ByVal OffsetCx As Double, ByVal OffsetCy As
Double, ByVal OffsetEx As Double, ByVal
OffsetEy As Double, ByVal CW_CCW As Integer,
ByVal StrVel As Double, ByVal MaxVel As
Double, ByVal Tacc As Double, ByVal Tdec As
Double, ByVal Svacc As Double, ByVal Svdec
As Double) As Integer
B_8154_start_sa_arc_zu(ByVal card_id As Integer,
ByVal Cx As Double, ByVal Cy As Double,
ByVal Ex As Double, ByVal Ey As Double,
ByVal CW_CCW As Integer, ByVal StrVel As
Double, ByVal MaxVel As Double, ByVal Tacc
```



```

As Double, ByVal Tdec As Double, ByVal Svacc
As Double, ByVal Svdec As Double) As Integer
B_8154_start_tr_arc2(AxisArray() As Integer,
OffsetCenter() As Double, OffsetEnd() As
Double, Byval CW_CCW As Integer, ByVal
StrVel As Double , ByVal MaxVel As Double,
ByVal Tacc As Double, ByVal Tdec As Double)
As Integer
B_8154_start_ta_arc2(AxisArray() As Integer,
CenterPos() As Double, EndPos() As Double,
Byval CW_CCW As Integer, ByVal StrVel As
Double , ByVal MaxVel As Double, ByVal Tacc
As Double, ByVal Tdec As Double) As Integer
B_8154_start_sr_arc2(AxisArray() As Integer,
OffsetCenter() As Double, OffsetEnd() As
Double, Byval CW_CCW As Integer, ByVal
StrVel As Double , ByVal MaxVel As Double,
ByVal Tacc As Double, ByVal Tdec As Double,
ByVal Svacc As Double, ByVal Svdec As
Double) As Integer
B_8154_start_sa_arc2(AxisArray() As Integer,
CenterPos() As Double, EndPos() As Double,
Byval CW_CCW As Integer, ByVal StrVel As
Double , ByVal MaxVel As Double, ByVal Tacc
As Double, ByVal Tdec As Double, ByVal Svacc
As Double, ByVal Svdec As Double) As Integer

```

**@ Argument**

**card\_id:** Specify the PCIe-8154 card index. The card\_id could be decided by DIP switch (SW1) or depend on slot sequence. Please refer to \_8154\_initial().

**AxisNo:** Axis number designated to move or stop.

card_id	Physical axis	AxisNo
0	0	0
	1	1
	2	2
	3	3

card_id	Physical axis	AxisNo
1	0	4
	1	5
	...	...

**OffsetCx:** X-axis (first axis of target axes) offset to center

**OffsetCy:** Y-axis (second axis of target axes) offset to center

**OffsetEx:** X-axis (first axis of target axes) offset to end of arc

**OffsetEy:** Y-axis offset to end of arc

**Cx:** X-axis (first axis of target axes) absolute position of center of arc

**Cy:** Y-axis (second axis of target axes) absolute position of center of arc

**Ex:** X-axis (first axis of target axes) absolute position of end of arc

**Ey:** Y-axis (second axis of target axes) absolute position of end of arc

**CW\_CCW:** Specified direction of arc

Value	Meaning
0	Clockwise(cw)
1	Counterclockwise(ccw)

**strVel:** Starting velocity of a velocity profile in units of pulse per second.

**MaxVel:** Maximum velocity in units of pulse per second.

**Tacc:** Specified acceleration time in units of seconds.

**Tdec:** Specified deceleration time in units of seconds.

**svacc:** Specified velocity interval in which S-curve acceleration is performed.

Note: SVacc = 0, for pure S-Curve. For more details, see section 4.2.4

**svdec:** specified velocity interval in which S-curve deceleration is performed.

Note: SVdec = 0, for pure S-Curve. For more details, see section 4.2.4

**\*AxisArray:** Array of axis number to perform interpolation.

Example:

```
I16 AxisArray[2] = {0, 3}; //axis 0, & axis 3
    (correct)
I16 AxisArray[2] = {1, 6}; //axis 1, & axis 6
    (incorrect)
```

**\*OffsetCenter:** Array of the offset to center (relative to the start position)

Example:

```
F64 OffsetCenter[2] = {2000.0, 0.0}; //offset
    from start position(initial point) for 1st &
    2nd axes
```

**\*OffsetEnd:** Array of the offset to end of arc (relative to the start position)

Example: F

```
64 OffsetEnd[2] = {4000.0, 0.0}; //offset from
    start position(initial point for 1st & 2nd
    axes
```

**\*CenterPos:** Array of the center of arc absolute position

Example:

```
F64 CenterPos[2] = {2000.0, 0.0}; //absolute
    center position for 1st & 2nd axes
```

**\*EndPos:** Array of the end point of arc absolute position

Example:

```
F64 EndPos[2] = {4000.0, 0.0}; //absolute end
    position for 1st & 2nd axes
```

## B.9 Helical Interpolation Motion

### @ Name

\_8154\_start\_tr\_helical – Begin a T-curve relative helical interpolation for X, Y and Z axis

`_8154_start_ta_helical` – Begin a T-curve absolute helical interpolation for X, Y and Z axis

`_8154_start_sr_helical` – Begins S-curve relative helical interpolation for X, Y and Z axis

`_8154_start_sa_helical` –Begins S-curve absolute helical interpolation for X, Y and Z axis

## @ Description

These functions perform helical interpolation motion with different profiles. Detail comparisons of these functions are described in follow table. These function can be used for circular interpolation between the axes X and Y and to adjust the angle of a jig toward an arc tangent point with the Z axis. Also, in this operation, the U axis operation will be a “dummy motion” and it cannot be used for any other purpose.

Function	Total axes	Velocity Profile	Relative Absolute	Target Axes
<code>_8154_start_tr_helical</code>	4	trapezoidal	R	Axes 0, 1 and 2
<code>_8154_start_ta_helical</code>	4	trapezoidal	A	Axes 0, 1 and 2
<code>_8154_start_sr_helical</code>	4	S-curve	R	Axes 0, 1 and 2
<code>_8154_start_sa_helical</code>	4	S-curve	A	Axes 0, 1 and 2

## @ Syntax

### C/C++(Windows XP/7/8.1)

```

I16 _8154_start_tr_helical(I16 card_id, F64
    OffsetCx, F64 OffsetCy, F64 OffsetEx, F64
    OffsetEy, F64 PitchDist, I16 CW_CCW, F64
    StrVel, F64 MaxVel, F64 Tacc, F64 Tdec);
I16 _8154_start_ta_helical(I16 card_id, F64 Cx,
    F64 Cy, F64 Ex, F64 Ey, F64 PitchPos, I16
    CW_CCW, F64 StrVel, F64 MaxVel, F64 Tacc,
    F64 Tdec);
I16 _8154_start_sr_helical(I16 card_id, F64
    OffsetCx, F64 OffsetCy, F64 OffsetEx, F64
    OffsetEy, F64 PitchDist, I16 CW_CCW, F64
    StrVel, F64 MaxVel, F64 Tacc, F64 Tdec, F64
    SVacc, F64 SVdec);
  
```

```
I16 _8154_start_sa_helical(I16 card_id, F64 Cx,
    F64 Cy, F64 Ex, F64 Ey, F64 PitchPos, I16
    CW_CCW, F64 StrVel, F64 MaxVel, F64 Tacc,
    F64 Tdec, F64 SVacc, F64 SVdec);
```

### Visual Basic6 (Windows XP/7/8.1)

```
B_8154_start_tr_helical Lib "8154.dll" Alias
    "_8154_start_tr_helical" (ByVal card_id As
    Integer, ByVal OffsetCx As Double, ByVal
    OffsetCy As Double, ByVal OffsetEx As
    Double, ByVal OffsetEy As Double, ByVal
    PitchDist As Double, ByVal CW_CCW As
    Integer, ByVal StrVel As Double, ByVal
    MaxVel As Double, ByVal Tacc As Double,
    ByVal Tdec As Double) As Integer
B_8154_start_ta_helical Lib "8154.dll" Alias
    "_8154_start_ta_helical" (ByVal card_id As
    Integer, ByVal Cx As Double, ByVal Cy As
    Double, ByVal Ex As Double, ByVal Ey As
    Double, ByVal PitchPos As Double, ByVal
    CW_CCW As Integer, ByVal StrVel As Double,
    ByVal MaxVel As Double, ByVal Tacc As
    Double, ByVal Tdec As Double) As Integer
B_8154_start_sr_helical Lib "8154.dll" Alias
    "_8154_start_sr_helical" (ByVal card_id As
    Integer, ByVal OffsetCx As Double, ByVal
    OffsetCy As Double, ByVal OffsetEx As
    Double, ByVal OffsetEy As Double, ByVal
    PitchDist As Double, ByVal CW_CCW As
    Integer, ByVal StrVel As Double, ByVal
    MaxVel As Double, ByVal Tacc As Double,
    ByVal Tdec As Double, ByVal SVacc As Double,
    ByVal SVdec As Double) As Integer
B_8154_start_sa_helical Lib "8154.dll" Alias
    "_8154_start_sa_helical" (ByVal card_id As
    Integer, ByVal Cx As Double, ByVal Cy As
    Double, ByVal Ex As Double, ByVal Ey As
    Double, ByVal PitchPos As Double, ByVal
    CW_CCW As Integer, ByVal StrVel As Double,
    ByVal MaxVel As Double, ByVal Tacc As
    Double, ByVal Tdec As Double, ByVal SVacc As
    Double, ByVal SVdec As Double) As Integer
```

## @ Argument

**card\_id:** Specify the PCIe-8154 card index. The card\_id could be decided by DIP switch (SW1) or depend on slot sequence. Please refer to \_8154\_initial().

**AxisNo:** Axis number designated to move or stop.

card_id	Physical axis	AxisNo
0	0	0
	1	1
	2	2
	3	3
1	0	4
	1	5
	...	...

**OffsetCx:** X-axis (first axis of target axes) offset to center

**OffsetCy:** Y-axis (second axis of target axes) offset to center

**OffsetEx:** X-axis (first axis of target axes) offset to end of arc

**OffsetEy:** Y-axis offset to end of arc

**PitchDist:** Z-axis specified relative distance to move

**Cx:** X-axis (first axis of target axes) absolute position of center of arc

**Cy:** Y-axis (second axis of target axes) absolute position of center of arc

**Ex:** X-axis (first axis of target axes) absolute position of end of arc

**Ey:** Y-axis (second axis of target axes) absolute position of end of arc

**PitchPos:** Z-axis specified absolute position to move

**CW\_CCW:** Specified direction of arc

Value	Meaning
0	Clockwise(cw)
1	Counterclockwise(ccw)

**strVel1:** Starting velocity of a velocity profile in units of pulse per second.

**MaxVel1:** Maximum velocity in units of pulse per second.

**Tacc:** Specified acceleration time in units of seconds.

**Tdec:** Specified deceleration time in units of seconds.

**svacc:** Specified velocity interval in which S-curve acceleration is performed.

Note: SVacc = 0, for pure S-Curve. For more details, see section 4.2.4

**svdec:** specified velocity interval in which S-curve deceleration is performed.

Note: SVdec = 0, for pure S-Curve. For more details, see section 4.2.4

## B.10 Home Return Mode

### @ Name

**\_8154\_set\_home\_config** – Set the configuration for home return move motion

**\_8154\_home\_move** – Perform a home return move.

**\_8154\_home\_search** – Perform an auto search home

### @ Description

**\_8154\_set\_home\_config**

Configures the home return mode, origin(ORG) and index signal(EZ) logic, EZ count, and ERC output options for the home\_move() function. Refer to section 4.2.10 for the setting of home\_mode control.

**\_8154\_home\_move**

This function will cause the axis to perform a home return move according to the **\_8164\_set\_home\_config()** function settings. The direction of movement is determined by the sign of

velocity parameter (MaxVel). Since the stopping condition of this function is determined by the `home_mode` setting, users should take care in selecting the initial moving direction. Users should also take care to handle conditions when the limit switch is touched or other conditions that are possible causing the axis to stop. For more detail description, see section 4.2.10

### \_8154\_home\_search

This function will cause the axis to perform a home-search move according to the `_8164_set_home_config()` function settings. The direction of movement is determined by the sign of velocity parameter (MaxVel). Since the stopping condition of this function is determined by the `home_mode` setting, users should take care in selecting the initial moving direction. Users should also take care to handle conditions when the limit switch is touched or other conditions that are possible causing the axis to stop. For more detail description, see section 4.2.11

## @ Syntax

### C/C++(Windows XP/7/8.1)

```
I16 _8154_set_home_config(I16 AxisNo, I16
    home_mode, I16 org_logic, I16 ez_logic, I16
    ez_count, I16 erc_out);
I16 _8154_home_move(I16 AxisNo, F64 StrVel, F64
    MaxVel, F64 Tacc);
I16 _8154_home_search(I16 AxisNo, F64 StrVel, F64
    MaxVel, F64 Tacc, F64 ORGOffset);
```

### Visual Basic (Windows XP/7/8.1)

```
B_8154_set_home_config(ByVal AxisNo As Integer,
    ByVal home_mode As Integer, ByVal org_logic
    As Integer, ByVal ez_logic As Integer, ByVal
    ez_count As Integer, ByVal erc_out As
    Integer) As Integer
B_8154_home_move(ByVal AxisNo As Integer, ByVal
    StrVel As Double, ByVal MaxVel As Double,
    ByVal Tacc As Double) As Integer
B_8154_home_search(ByVal AxisNo As Integer, ByVal
    StrVel As Double, ByVal MaxVel As Double,
    ByVal Tacc As Double, ByVal ORGOffset As
    Double) As Integer
```



**@ Argument**

**AxisNo:** Axis number designated to move or stop.

card_id	Physical axis	AxisNo
0	0	0
	1	1
	2	2
	3	3
1	0	4
	1	5
	...	...

**home\_mode:** Stopping modes for home return, This value is between 0 to 12. Please refer to the operation theory section 4.2.10

**org\_logic:** Action logic configuration for ORG

Value	Meaning
0	Active low
1	Active high

**ez\_logic:** Action logic configuration for EZ

Value	Meaning
0	Active low
1	Active high

**ez\_count:** 0-15 (Please refer to section 4.2.10)

**erc\_out:** Set ERC output options.

Value	Meaning
0	no ERC out
1	ERC signal out when home-move finishing

**strVel:** Starting velocity of a velocity profile. (unit: pulse/sec)

**maxVel:** Maximum velocity. (unit: pulse/sec)

**Tacc:** Specified acceleration time (Unit: sec)

**ORGoffset:** The escape pulse amounts when home search touches the ORG signal (Unit: pulse)

## B.11 Manual Pulse Generator Motion

### @ Name

**\_8154\_disable\_manual\_pulse\_generator\_input** – Disable the manual pulse generator input

**\_8154\_manual\_pulse\_generator\_pmove** – Manual manual pulse generator p\_move

**\_8154\_manual\_pulse\_generator\_vmove** – Manual manual pulse generator v\_move

**\_8154\_set\_manual\_pulse\_generator\_ratio** – Set manual manual pulse generator ratio for actual output pulse rate

**\_8154\_set\_manual\_pulse\_generator\_iptmode** – Set the input signal modes of manual pulse generator

### @ Description

**\_8154\_disable\_manual\_pulse\_generator\_input**

This function is used to set the manual pulse generator input disable or enable.

**\_8154\_manual\_pulse\_generator\_pmove**

With this command, the axis begins to move according to the manual pulse input. The axis will output one pulse when it receives one manual pulse, until the **\_8154\_disable\_manual\_pulse\_generator\_input** function disables the manual pulse generator or the output pulse number reaches the distance.

**\_8154\_manual\_pulse\_generator\_vmove**

With this command, the axis begins to move according to the manual pulse input. The axis will output one pulse when it receives one manual pulse, until the **\_8154\_disable\_manual\_pulse\_generator\_input** function disables the manual pulse generator.

**`_8154_set_manual_pulse_generator_ratio`**

Set manual pulse ratio for actual output pulse rate. The formula for manual pulse output rate is:

Output Pulse Count = Input manual pulse generator Count x (MultiF + 1) x DivF / 2048

The DivF = 1~2047 Divide Factor

The MultiF= 0~31 Multiplication Factor

**`_8154_set_manual_pulse_generator_iptmode`**

This function is used to configure the input mode of manual manual pulse generator.

**@ Syntax****C/C++(Windows XP/7/8.1)**

```
I16 _8154_disable_manual_pulse
    generator_input(I16 AxisNo, U16 Disable );
I16 _8154_manual_pulse_generator_pmove(I16
    AxisNo, F64 Dist, F64 SpeedLimit);
I16 _8154_manual_pulse_generator_vmmove(I16
    AxisNo, F64 SpeedLimit);
I16 _8154_set_manual_pulse_generator_ratio(I16
    AxisNo, I16 DivF, I16 MultiF);
I16 _8154_set_manual_pulse_generator_iptmode(I16
    AxisNo, I16 InputMode, I16 Inverse);
```

**Visual Basic (Windows XP/7/8.1)**

```
B_8154_disable_manual_pulse_generator_input(ByVal
    AxisNo As Integer, ByVal Disable As Integer)
    As Integer
B_8154_manual_pulse_generator_pmove(ByVal AxisNo
    As Integer, ByVal Dist As Double, ByVal
    SpeedLimit As Double) As Integer
B_8154_manual_pulse_generator_vmmove(ByVal AxisNo
    As Integer, ByVal SpeedLimit As Double) As
    Integer
B_8154_set_manual_pulse_generator_ratio(ByVal
    AxisNo As Integer, ByVal DivF As Integer,
    ByVal MultiF As Integer) As Integer
B_8154_set_manual_pulse_generator_iptmode(ByVal
    AxisNo As Integer, ByVal InputMode As
```

Integer, ByVal Inverse As Integer) As Integer

## @ Argument

**AxisNo:** Axis number designated to move or stop.

card_id	Physical axis	AxisNo
0	0	0
	1	1
	2	2
	3	3
1	0	4
	1	5
	...	...

**Disable:** Disable manual pulse generator input.

Disable = 1, disable manual pulse generator

Disable = 0, enable manual pulse generator

**Dist:** Specified relative distance to move (unit: pulse)

For example, if SpeedLimit is set to be 100pps, then the axis can move at fastest 100pps, even the input manual pulse generator signal rate is more than 100pps.

**DivF:** Divide factor (1-2047)

Note: When 0 or 2048 is entered, the division circuit will be OFF.

**MultiF:** Multiplication factor (0-31)

**InputMode:** Setting of manual pulse input mode from the PA and PB pins

Value	Meaning
0	1X AB phase type pulse input
1	2X AB phase type pulse input
2	4X AB phase type pulse input
3	CW/CCW type pulse input

**Inverse:** Reverse the moving direction from pulse direction

Value	Meaning
0	no inverse
1	Reverse moving direction

## B.12 Motion Status

### @ Name

`_8154_motion_done` – Return the motion status

### @ Description

`_8154_motion_done`:

Return the motion status of the 8154. The return code show as below:

0	Normal stopped condition
1	Waiting for DR
2	Waiting for CSTA input
3	Waiting for an internal synchronous signal
4	Waiting for another axis to stop
5	Waiting for a completion of ERC timer
6	Waiting for a completion of direction change timer
7	Correcting backlash
8	Wait PA/PB
9	At FA speed
10	At FL Speed
11	Accelerating
12	At FH Speed
13	Decelerating
14	Wait INP
15	Others(Controlling Start)
16	SALM
17	SPEL

**Table 1:**

18	SMEL
19	SEMG
20	SSTP
21	SERC

**Table 1:**

### @ Syntax

#### C/C++(Windows XP/7/8.1)

```
I16 _8154_motion_done(I16 AxisNo)
```

#### Visual Basic (Windows XP/7/8.1)

```
B_8154_motion_done(ByVal AxisNo As Integer) As Integer
```

### @ Argument

**AxisNo:** Axis number designated to move or stop.

card_id	Physical axis	AxisNo
0	0	0
	1	1
	2	2
	3	3
1	0	4
	1	5
	...	...

## B.13 Motion Interface I/O

### @ Name

**\_8154\_set\_servo** – Set the ON-OFF state of the SVON signal

**\_8154\_set\_pcs\_logic** – Set the logic of PCS signal

**\_8154\_set\_pcs** – Enable the PCS for position override

**\_8154\_set\_clr\_mode** – Set the mode of CLR signal

**\_8154\_set\_inp** – Set the logic of INP signal and operating mode

`_8154_set_alm` – Set the logic of ALM signal and operating mode

`_8154_set_erc` – Set the logic of ERC signal and operating mode

`_8154_set_erc_out` – Output an ERC signal

`_8154_clr_erc` – Clear the ERC signal

`_8154_set_sd` – Set the logic SD signal and operating mode

`_8154_enable_sd` – Enable SD signal

`_8154_set_limit_logic` – Set the logic of PEL/MEL signal

`_8154_set_limit_mode` – Set PEL/MEL operating mode

`_8154_get_io_status` – Get all the motion I/O statuses of each 8154

## @ Description

`_8154_set_servo`:

You can set the ON-OFF state of the SVON signal with this function. The default value is 1(OFF), which means the SVON is open to GND.

`_8154_set_pcs_logic`:

Set the active logic of the PCS signal input

#### `_8154_set_pcs:`

Enable the position override when input signal PCS is turn ON. The PCS terminal status can be monitored by the “`_8154_get_io_status`” function.

#### `_8154_set_clr_mode`

CLR inputted signal can reset specified counters(command, position, error and general purpose counter). The reset action could be set by this function. The reset action mode has 4 types. For details refer to arguments description.

#### `_8154_set_inp:`

Set the active logic of the In-Position signal input from the servo driver. Users can select whether they want to enable this function. It is disabled by default.

#### `_8154_set_alm:`

Set the active logic of the ALARM signal input from the servo driver. Two reacting modes are available when the ALARM signal is active.

#### `_8154_set_erc:`

Users can set the logic and on time of the ERC with this function. It also can set the manual pulse generator width of ERC signal.

#### `_8154_set_erc_out:`

This function is used to output the ERC signal manually.

#### `_8154_clr_erc:`

This function is used to reset the output when the ERC signal output is specified to a level type output.

#### `_8154_set_sd:`

Set the active logic, latch control, and operating mode of the SD signal input from a mechanical system. Users can select whether they want to enable this function by `_8154_enable_sd`. It is disabled by default

#### `_8154_enable_sd:`

Enable the SD signal input. Default setting is default.



**`_8154_set_limit_logic:`**

Set the EL logic, normal open or normal closed.

**`_8154_set_limit_mode:`**

Set the reacting modes of the EL signal.

**`_8154_get_io_status:`**

Get all the I/O statuses for each axis. The definition for each bit is as follows:

Bit	Name	Description
0	RDY	RDY pin input
1	ALM	Alarm Signal
2	+EL	Positive Limit Switch
3	-EL	Negative Limit Switch
4	ORG	Origin Switch
5	DIR	DIR output
6	EMG	EMG status
7	PCS	PCS signal input
8	ERC	ERC pin output
9	EZ	Index signal
10	CLR	Clear signal
11	LTC	Latch signal input
12	SD	Slow Down signal input
13	INP	In-Position signal input
14	SVON	Servo-ON output status

**@ Syntax****C/C++(Windows XP/7/8.1)**

```

I16 _8154_set_servo(I16 AxisNo, I16 on_off);
I16 _8154_set_pcs_logic(I16 AxisNo, I16
    pcs_logic);
I16 _8154_set_pcs(I16 AxisNo, I16 enable);
I16 _8154_set_clr_mode(I16 AxisNo, I16 clr_mode,
    I16 targetCounterInBit);
I16 _8154_set_inp(I16 AxisNo, I16 inp_enable, I16
    inp_logic);

```

```
I16 _8154_set_alm(I16 AxisNo, I16 alm_logic, I16
alm_mode);
I16 _8154_set_erc(I16 AxisNo, I16 erc_logic, I16
erc_pulse_width, I16 erc_mode);
I16 _8154_set_erc_out(I16 AxisNo);
I16 _8154_clr_erc(I16 AxisNo);
I16 _8154_set_sd(I16 AxisNo, I16 sd_logic, I16
sd_latch, I16 sd_mode);
I16 _8154_enable_sd(I16 AxisNo, I16 enable);
I16 _8154_set_limit_logic(I16 AxisNo, U16 Logic
);
I16 _8154_set_limit_mode(I16 AxisNo, I16
limit_mode);
I16 _8154_get_io_status(I16 AxisNo, U16 *io_sts);
```

### **Visual Basic (Windows XP/7/8.1)**

```
B_8154_set_servo(ByVal AxisNo As Integer, ByVal
on_off As Integer) As Integer
B_8154_set_pcs_logic(ByVal AxisNo As Integer,
ByVal pcs_logic As Integer) As Integer
B_8154_set_pcs(ByVal AxisNo As Integer, ByVal
enable As Integer)As Integer
B_8154_set_clr_mode(ByVal AxisNo As Integer,
ByVal clr_mode As Integer, ByBal
targetCounterInBit as Integer) As Integer
B_8154_set_inp(ByVal AxisNo As Integer, ByVal
inp_enable As Integer, ByVal inp_logic As
Integer) As Integer
B_8154_set_alm(ByVal AxisNo As Integer, ByVal
alm_logic As Integer, ByVal alm_mode As
Integer) As Integer
B_8154_set_erc(ByVal AxisNo As Integer, ByVal
erc_logic As Integer, ByVal erc_pulse_width
As Integer, ByVal erc_mode As Integer) As
Integer
B_8154_set_erc_out(ByVal AxisNo As Integer) As
Integer
B_8154_clr_erc(ByVal AxisNo As Integer) As
Integer
B_8154_set_sd(ByVal AxisNo As Integer, ByVal
sd_logic As Integer, ByVal sd_latch As
Integer, ByVal sd_mode As Integer) As
Integer
```

```

B_8154_enable_sd(ByVal AxisNo As Integer, ByVal
    Enable As Integer) As Integer
B_8154_set_limit_logic(ByVal AxisNo As Integer,
    ByVal Logic As Integer) As Integer
B_8154_set_limit_mode(ByVal AxisNo As Integer,
    ByVal limit_mode As Integer) As Integer
I16 _8154_get_io_status(ByVal AxisNo As Integer,
    io_sts As Integer) As Integer
    
```

**@ Argument**

**AxisNo:** Axis number designated to move or stop.

card_id	Physical axis	AxisNo
0	0	0
	1	1
	2	2
	3	3
1	0	4
	1	5
	...	...

**on\_off:** ON-OFF state of SVON signal

Value	Meaning
0	ON
1	OFF

**pcs\_logic:** PCS signal input logic

Value	Meaning
0	Negative logic
1	Positive logic

**enable:** enable or disable

Value	Meaning
0	Disable
1	Enable

**clr\_mode:** Specify a CLR input clear mode

clr\_mode = 0 , Clear on the falling edge (default)

clr\_mode = 1 , Clear on the rising edge

clr\_mode = 2 , Clear on a LOW level

clr\_mode = 3 , Clear on a HIGH level

**targetCounterInBit:** Enable/Disable clear target counter in bit

Value	Meaning
Bit	Description
0	Reset command counter when CLR input turns ON
1	Reset position counter when CLR input turns ON
2	Reset error counter when CLR input turns ON
3	Reset general purpose counter when CLR input turns ON

**inp\_enable:** INP function enabled/disabled

inp\_enable = 0, Disabled (default)

inp\_enable = 1, Enabled

**inp\_logic:** Set the active logic for the INP signal

Value	Meaning
0	Negative logic
1	Positive logic

**alm\_logic:** Setting of active logic for ALARM signals

Value	Meaning
0	Negative logic
1	Positive logic

**alm\_mode:** Reacting modes when receiving an ALARM signal.

Value	Meaning
0	motor immediately stops (default)
1	motor decelerates then stops

**erc\_logic:** Set the active logic for the ERC signal

Value	Meaning
0	Negative logic
1	Positive logic

**erc\_pulse\_width:** Set the pulse width of the ERC signal

Value	Meaning
0	12 $\mu$ s
1	102 $\mu$ s
2	409 $\mu$ s
3	1.6 ms
4	13 ms
5	52 ms
6	104 ms
7	Level output

**erc\_mode:**

Value	Meaning
0	Disable
1	Output ERC when stopped by EL, ALM, or EMG input
2	Output ERC when complete home return
3	Both 1 and 2

**sd\_logic:**

Value	Meaning
0	Negative logic
1	Positive logic

**sd\_latch:** Set the latch control for the SD signal

Value	Meaning
0	Do not latch
1	latch

**sd\_mode:** Set the reacting mode of the SD signal

Value	Meaning
0	slow down only
1	slow down then stop

**enable:** Set the ramping-down point for high speed feed.

Value	Meaning
0	Automatic setting
1	Manual setting (default)

**Logic:** Set the PEL/MEL logic.

Value	Meaning
0	Normal low(normal open)
1	Normal high(normal close)

**limit\_mode:**

Value	Meaning
0	Stop immediately
1	Slow down then stop

**\*io\_sts:** I/O status. Please refer to 6.12 function description.

## B.14 Interrupt Control

### @ Name

`_8154_int_control` – Enable/Disable INT service

`_8154_set_motion_int_factor` – Set the factors of motion related interrupts

`_8154_wait_error_interrupt` – Wait error related interrupts

`_8154_wait_motion_interrupt` – Wait motion related interrupts

### @ Description

`_8154_int_control:`

This function is used to enable the Windows interrupt event to host PC.

#### **`_8154_set_motion_int_factor:`**

This function allows users to select motion related factors to initiate the event int. The error can never be masked once the interrupt service is turned on by `_8154_int_control()`. Once the Interrupt function is enabled, you can use `_8154_wait_motion_interrupt()` to wait event.

#### **`_8154_wait_error_interrupt:`**

When user enabled the Interrupt function by `_8154_int_control()`. He could use this function to wait the error interrupts. Please refer to the operation theory section 4.8

#### **`_8154_wait_motion_interrupt:`**

When user enabled the Interrupt function by `_8154_int_control()` and set the interrupt factors by `_8154_set_motion_int_factor()`. User could use this function to wait the specific interrupt. When this function was running, the process would never stop until evens were triggered or the function was time out.

## **@ Syntax**

### **C/C++(Windows XP/7/8.1)**

```
I16 _8154_int_control(I16 card_id, I16
    intFlag);
I16 _8154_set_motion_int_factor(I16 AxisNo,
    U32 int_factor );
I16 _8154_wait_error_interrupt(I16 AxisNo,
    I32 TimeOut_ms );
I16 _8154_wait_motion_interrupt(I16 AxisNo, I16
    IntFactorBitNo, I32 TimeOut_ms );
```

### **Visual Basic (Windows XP/7/8.1)**

```
B_8154_int_control(ByVal card_id As Integer,
    ByVal intFlag As Integer) As Integer
B_8154_wait_error_interrupt(ByVal AxisNo As
    Integer, ByVal TimeOut_ms As Long) As
    Integer
```

```

B_8154_wait_motion_interrupt(ByVal AxisNo As Integer, ByVal IntFactorBitNo As Integer,
    ByVal TimeOut_ms As Long) As Integer
B_8154_set_motion_int_factor(ByVal AxisNo As Integer, ByVal int_factor As Long) As Integer
  
```

## @ Argument

**card\_id**: Specify the index of target PCIe-8154 card. The **card\_id** could be decided by DIP switch (SW1) or depend on slot sequence. Please refer to **\_8154\_initial()**.

**intFlag**: Enable/Disable the Interrupt function

Value	Meaning
0	Disable
1	Enable

**AxisNo**: Axis number designated to move or stop.

card_id	Physical axis	AxisNo
0	0	0
	1	1
	2	2
	3	3
1	0	4
	1	5
	...	...

**int\_factor**: interrupt factor

motion INT factors (Value, 0: Disable, 1: Enable)

Bit	Description
0	Normal stop
1	Next command in buffer starts
2	Command pre-register 2 is empty and allow new command to write
3	(Reserved) (Always set to 0)
4	Acceleration Start
5	Acceleration End



Bit	Description
6	Deceleration Start
7	Deceleration End
8	+Soft limit or comparator 1 is ON
9	-Soft limit or comparator 2 is ON
10	Error comparator or comparator 3 is ON
11	General comparator or comparator 4 is ON
12	Trigger comparator or comparator 5 is ON
13	Counter is reset by CLR input
14	Counter is latched by LTC input
15	Counter is latched by ORG Input
16	SD input turns on
17	(Reserved) (Always set to 0)
18	CSTA input or <code>_8154_start_move_all()</code> turns on
19-31	Not define (Always set to 0)

**TimeOut\_ms:** Specifies the time-out interval, in milliseconds. If TimeOut\_ms is zero, the function tests the states of the specified objects and returns immediately. If TimeOut\_ms is -1, the function's time-out interval never elapses (infinite).

**IntFactorBitNo:** Specifies the bit number of the INT factor.

e.g. IntFactorBitNo = 4, It means waiting the factor of "Acceleration Start" interrupt.

## B.15 Position Control and Counters

### @ Name

`_8154_get_position` – Get the value of feedback position counter

`_8154_set_position` – Set the feedback position counter

`_8154_get_command` – Get the value of command position counter

`_8154_set_command` – Set the command position counter

`_8154_get_error_counter` – Get the value of position error counter

`_8154_reset_error_counter` – Reset the position error counter

`_8154_get_general_counter` – get the value of general counter

`_8154_set_general_counter` – Set the general counter

`_8154_get_target_pos` – Get the value of target position recorder

`_8154_reset_target_pos` – Reset target position recorder

`_8154_get_res_distance` – Get remaining pulses accumulated from motion

`_8154_set_res_distance` – Set remaining pulses record

`_8154_get_ring_counter` – Acquires limitation value of ring counter

`_8154_set_ring_counter` – Sets ring counter limitation and enables ring counter function

`_8154_escape_home` – Leaves from the home position, with positivity of negative move set by the MaxVel

## **@ Description**

`_8154_get_position:`

This function is used to read the feedback position counter value. Note that this value has already been processed by the move ratio setting by `_8154_set_move_ratio()`. If the move ratio is 0.5, than the value of position will be twice. The source of the feedback counter is selectable by the function `_8154_set_feedback_src()` to be external EA/EB or internal pulse output of 8154 .

**`_8154_set_position:`**

This function is used to change the feedback position counter to the specified value. Note that the value to be set will be processed by the move ratio. If move ratio is 0.5, then the set value will be twice as given value.

**`_8154_get_command:`**

This function is used to read the value of the command position counter. The source of the command position counter is the pulse output of the 8154.

**`_8154_set_command:`**

This function is used to change the value of the command position counter.

**`_8154_get_error_counter:`**

This function is used to read the value of the position error counter.

**`_8154_reset_error_counter:`**

This function is used to clear the position error counter.

**`_8154_get_general_counter:`**

This function is used to read the value of the general counter.

**`_8154_set_general_counter:`**

This function is used to set the counting source of and change the value of general counter (By default, the source is manual pulse generator input).

**`_8154_get_target_pos:`**

This function is used to read the value of the target position recorder. The target position recorder is maintained by the 8154 software driver. It records the position to settle down for current running motion.

**`_8154_reset_target_pos:`**

This function is used to set new value for the target position recorder. It is necessary to call this function when home return completes, or when a new feedback counter value is set by function `_8154_set_position()`.

### \_8154\_get\_res\_distance:

This function is used to read the value of the residue distance recorder. The target position recorder is maintained by the 8154 software driver. It records the position to settle down for current running motion.

### \_8154\_set\_res\_distance:

This function is used to change the value of the residue distance counter

### \_8154\_get\_ring\_counter

Acquires limitation value of ring counter.

### \_8154\_set\_ring\_counter

Sets ring counter limitation and enables ring counter function, wherein command and feedback counters operate as a ring counter. When ring counter limitation is set to zero, ring counter function is disabled.

As shown, when ring counter limitation (I32 RingVal) is set to four, command and feedback counters count up until counter value equals four, at which point command and feedback counters reset to zero and the operation is repeated.

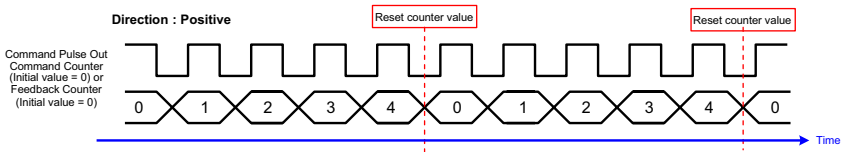

Accordingly, as is further shown, when ring counter limitation (I32 RingVal) is set to four, command and feedback counters count down until counter value equals zero, command and feedback counters are reset to four, and the operation is repeated.

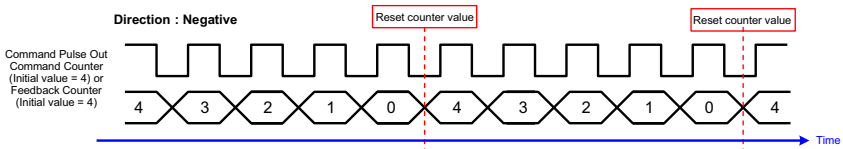

**\_8154\_escape\_home**

Leaves from the home position, with positivity of negative move set by the MaxVel

**@ Syntax****C/C++(Windows XP/7/8.1)**

```

I16 _8154_get_position(I16 AxisNo, F64 *Pos);
I16 _8154_set_position(I16 AxisNo, F64 Pos);
I16 _8154_get_command(I16 AxisNo, I32 *Command);
I16 _8154_set_command(I16 AxisNo, I32 Command);
I16 _8154_get_error_counter(I16 AxisNo, I16
    *error);
I16 _8154_reset_error_counter(I16 AxisNo);
I16 _8154_get_general_counter(I16 AxisNo, F64
    *CntValue);
I16 _8154_set_general_counter(I16 AxisNo, I16
    CntSrc, F64 CntValue);
I16 _8154_get_target_pos(I16 AxisNo, F64 *T_pos);
I16 _8154_reset_target_pos(I16 AxisNo, F64
    T_pos);
I16 _8154_get_res_distance(I16 AxisNo, F64
    *Res_Distance);
I16 _8154_set_res_distance(I16 AxisNo, F64
    Res_Distance);
I16 _8154_set_ring_counter( I16 AxisNo, I32
    RingVal );
I16 _8154_get_ring_counter( I16 AxisNo, I32
    *RingVal );
I16 _8154_escape_home (I16 AxisNo, F64 StrVel,
    F64 MaxVel, F64 Tacc);

```

**Visual Basic (Windows XP/7/8.1)**

```

B_8154_get_position(ByVal AxisNo As Integer, Pos
    As Double) As Integer
B_8154_set_position(ByVal AxisNo As Integer,
    ByVal Pos As Double) As Integer
B_8154_get_command(ByVal AxisNo As Integer, Cmd
    As Long) As Integer
B_8154_set_command(ByVal AxisNo As Integer, ByVal
    Cmd As Long) As Integer
B_8154_get_error_counter(ByVal AxisNo As Integer,
    ByRef error As Integer) As Integer

```

```

B_8154_reset_error_counter(ByVal AxisNo As Integer) As Integer
B_8154_set_general_counter(ByVal AxisNo As Integer, ByVal CntSrc As Integer, ByVal CntValue As Double) As Integer
B_8154_get_general_counter(ByVal AxisNo As Integer, ByRef Pos As Double) As Integer
B_8154_reset_target_pos(ByVal AxisNo As Integer, ByVal Pos As Double) As Integer
B_8154_get_target_pos(ByVal AxisNo As Integer, ByRef Pos As Double) As Integer
B_8154_set_res_distance(ByVal AxisNo As Integer, ByVal Res_Distance As Double) As Integer
B_8154_get_res_distance(ByVal AxisNo As Integer, ByRef Res_Distance As Double) As Integer
B_8154_set_ring_counter (ByVal AxisNo As Integer, ByVal RingVal As Long) As Integer
B_8154_get_ring_counter (ByVal AxisNo As Integer, RingVal As Long) As Integer
B_8154_escape_home (ByVal AxisNo As Integer, ByVal StrVel As Double, ByVal MaxVel As Double, ByVal Tacc As Double) As Integer
  
```

## @ Argument

**AxisNo:** Axis number designated to move or stop.

card_id	Physical axis	AxisNo
0	0	0
	1	1
	2	2
	3	3
1	0	4
	1	5
	...	...

**Pos, \*Pos:** Feedback position counter value, (\_8154\_get/set\_position)

range: -134217728 to 134217727

**Cmd, \*Cmd:** Command position counter value,

range: -134217728 to 134217727

**\*error**: Position error counter value,  
range: -32768 to 32767

**CntSrc**: general counter source

Value	Meaning
0	Command pulse
1	EA/EB
2	manual pulse generator input
3	System clock*2

**CntValue**, **\*CntValue**: the counter value

**TargetPos**, **\*TargetPos**: Target position recorder value,  
range: -134217728 to 134217727

**ResDistance**, **\*ResDistance**: residue distance

**RingVal**, **\*RingVal**: Limitation value of ring counter.( 0 < RingVal < 134217727 ), wherein if RingVal equals zero, disable ring counter function

**strVe1**: Starting velocity of a velocity profile in pulses per second

**MaxVe1**: Maximum velocity in pulses per second

**Tacc**: Specified acceleration time in seconds

## B.16 Position Compare and Latch

### @ Name

**\_8154\_set\_trigger\_logic** – Set the CMP signal's logic

**\_8154\_set\_trigger\_comparator** – Set the trigger comparator

**\_8154\_set\_error\_comparator** – Set the error comparator

**\_8154\_set\_general\_comparator** – Set the general comparator

**\_8154\_set\_latch\_source** – Set the latch timing for a counter

`_8154_set_ltc_logic` – Set the logic of LTC signal

`_8154_get_latch_data` – Get the latch data from counter

## @ Description

`_8154_set_trigger_logic`:

This function is used to set the logic of CMP single.

`_8154_set_error_comparator`:

This function is used to set the comparing method and value for the error comparator. When the position error counter's value reaches the comparing value, the 8154 will generate an interrupt to the host PC. Also see Section B.14 on page 114.

`_8154_set_general_comparator`:

This function is used to set the comparing source counter, comparing method and value for the general comparator. When the comparison conditions are met, there is one of the 4 reactions will be done. The detail setting, see the argument description.

`_8154_set_trigger_comparator`:

This function is used to set the comparing source counter, comparing method and value for the trigger comparator. When the comparison source counter's value reaches the comparing value, the 8154 will generate a pulse output via CMP and an interrupt (event\_int\_status, bit 12) will also be sent to host PC.

`_8154_set_latch_source`:

There are 4 latch triggering source. By using this function, user can choose the event source to latch counters' data.

`_8154_set_ltc_logic`:

This function is used to set the logic of the latch input.

`_8154_get_latch_data`:

After the latch signal arrived, the function is used to read the latched value of counters.



**@ Syntax****C/C++(Windows XP/7/8.1)**

```

I16 _8154_set_trigger_logic(I16 AxisNo, I16
    Logic);
I16 _8154_set_error_comparator(I16 AxisNo, I16
    CmpMethod, I16 CmpAction, I32 Data);
I16 _8154_set_general_comparator(I16 AxisNo, I16
    CmpSrc, I16 CmpMethod,
I16 CmpAction, I32 Data);
I16 _8154_set_trigger_comparator(I16 AxisNo, I16
    CmpSrc, I16 CmpMethod,
I32 Data);
I16 _8154_set_latch_source(I16 AxisNo, I16
    LtcSrc);
I16 _8154_set_ltc_logic(I16 AxisNo, I16 LtcLogic);
I16 _8154_get_latch_data(I16 AxisNo, I16
    CounterNo, F64 *Pos);

```

**Visual Basic (Windows XP/7/8.1)**

```

B_8154_set_trigger_logic(ByVal AxisNo As Integer,
    ByVal Logic As Integer) As Integer
B_8154_set_error_comparator(ByVal AxisNo As
    Integer, ByVal CmpMethod As Integer, ByVal
    CmpAction As Integer, ByVal Data As Long) As
    Integer
B_8154_set_general_comparator(ByVal AxisNo As
    Integer, ByVal CmpSrc As Integer, ByVal
    CmpMethod As Integer, ByVal CmpAction As
    Integer, ByVal Data As Long) As Integer
B_8154_set_trigger_comparator(ByVal AxisNo As
    Integer, ByVal CmpSrc As Integer, ByVal
    CmpMethod As Integer, ByVal Data As Long) As
    Integer
B_8154_set_latch_source(ByVal AxisNo As Integer,
    ByVal LtcSrc As Integer) As Integer
B_8154_set_ltc_logic(ByVal AxisNo As Integer,
    ByVal StcLogic As Integer) As Integer
B_8154_get_latch_data(ByVal AxisNo As Integer,
    ByVal CounterNo As Integer, Pos As Double)
    As Integer

```

## @ Argument

**AxisNo:** Axis number designated to move or stop.

card_id	Physical axis	AxisNo
0	0	0
	1	1
	2	2
	3	3
1	0	4
	1	5
	...	...

**Logic:** logic of comparing trigger

Value	Meaning
0	Negative logic
1	Positive logic

**CmpSrc:** The comparing source counters

Value	Meaning
0	Command counter
1	Feedback counter
2	Error counter
3	General counter

**CmpMethod:** The comparing methods

Value	Meaning
0	No Compare(Disable)
1	Data = Source counter (direction independent)
2	Data = Source counter (Count up only)
3	Data = Source counter (Count down only)
4	Data > Source counter
5	Data < Source counter

**Data:** Comparing value (Position)

**CmpAction:**

Value	Meaning
0	No action
1	Stop immediately
2	Slow down then stop

**ltc\_src:**

Value	Meaning
0	LTC pin input
1	ORG pin input
2	general comparator conditions are met
3	trigger comparator conditions are met

**ltc\_logic:** LTC signal operation edge

Value	Meaning
0	Negative logic
1	Positive logic

**CounterNo:** Specified the counter to latch

Value	Meaning
0	Command counter
1	Feedback counter
2	Error counter
3	General counter

**\*Pos:** Latch data (Position)

## B.17 Continuous motion

### @ Name

**\_8154\_set\_continuous\_move** – Enable continuous motion for absolute motion

**\_8154\_check\_continuous\_buffer** – Check if the buffer is empty

**\_8154\_dwell\_move** – Set a dwell move

## @ Description

### \_8154\_set\_continuous\_move:

This function is necessary before and after continuous motion command sequences

### \_8154\_check\_continuous\_buffer:

This function is used to detect if the command pre-register (buffer) is empty or not. Once the command pre-register (buffer) is empty, users may write the next motion command into it. Otherwise, the new command will overwrite the previous command in the 2nd command pre-register. If the return code is 1 means buffer is full. Otherwise return code is 0, buffer is not full.

### \_8154\_dwell\_move:

This function is used to start a dwell move that means the move does not cause real motion for a specific time.

Example:

```
_8154_set_continuous_move( 2, 1 ); // start
    continuous move
_8154_start_tr_move( 2, 20000.0, 10.0, 10000.0,
    0.1, 0.1);
_8154_dwell_move( 2, 2000); //dwell move for 2
    sec.
_8154_start_sr_move( 2, 20000.0, 10.0, 10000.0,
    0.1, 0.1, 0, 0 );
_8154_set_continuous_move( 2, 0 ); //end
    continuous move
```

## @ Syntax

### **C/C++(Windows XP/7/8.1)**

```
I16 _8154_set_continuous_move(I16 AxisNo, I16
    Enable);
I16 _8154_check_continuous_buffer(I16 AxisNo);
I16 _8154_dwell_move(I16 AxisNo, F64 ms);
```

### **Visual Basic (Windows XP/7/8.1)**

```
B_8154_set_continuous_move(ByVal AxisNo As
    Integer, ByVal Enable As Integer) As Integer
B_8154_check_continuous_buffer(ByVal AxisNo As
    Integer) As Integer
```

```
B_8154_dwell_move(ByVal AxisNo As Integer, ByVal
ms As Double) As Integer
```

### @ Argument

**AxisNo:** Axis number designated to move or stop.

card_id	Physical axis	AxisNo
0	0	0
	1	1
	2	2
	3	3
1	0	4
	1	5
	...	...

**Enable:** continuous motion switch logic

Value	Meaning
0	continuous motion sequence is finished (Disable)
1	continuous motion sequence is started (Enable)

**millisecond:** Time of dwell move. the unit is in milliseconds.

## B.18 Multiple Axes Simultaneous Operation

### @ Name

**\_8154\_set\_tr\_move\_all** – Multi-axis simultaneous operation setup

**\_8154\_set\_ta\_move\_all** – Multi-axis simultaneous operation setup

**\_8154\_set\_sr\_move\_all** – Multi-axis simultaneous operation setup

**\_8154\_set\_sa\_move\_all** – Multi-axis simultaneous operation setup

**\_8154\_start\_move\_all** – Begin a multi-axis trapezoidal profile motion

## `_8154_stop_move_all` – Simultaneously stop Multi-axis motion

### @ Description

These functions are related to simultaneous operations of multi-axes, even in different cards. The simultaneous multi-axis operation means to start or stop moving specified axes at the same time. The axes moved are specified by the parameter “AxisArray,” and the number of axes are defined by parameter “TotalAxes” in `_8154_set_tr_move_all()`.

When properly setup with `_8154_set_xx_move_all()`, the function `_8154_start_move_all()` will cause all specified axes to begin a trapezoidal relative movement, and `_8154_stop_move_all()` will stop them. Both functions guarantee that motion Starting/Stopping on all specified axes are at the same time. Note that it is necessary to make connections according to Section 1.7 on page 10 if these two functions are needed.

The following code demos how to utilize these functions. This code moves axis 0 and axis 1 to distance 80000.0 and 120000.0 respectively. If we choose velocities and accelerations that are proportional to the ratio of distances, then the axes will arrive at their endpoints at the same time.

#### Example:

```
I16 axes[2] = {0, 1};
F64 dist[2] = {80000.0, 120000.0},
F64 str_vel[2] = {0.0, 0.0},
F64 max_vel[2] = {4000.0, 6000.0},
F64 Tacc[2] = {0.1, 0.6},
F64 Tdec[2] = {0.1, 0.6};

_8154_set_tr_move_all(2, axes, dist, str_vel,
    max_vel, Tacc, Tdec);
_8154_start_move_all(axes[0]);
```

### @ Syntax

#### C/C++(Windows XP/7/8.1)

```
I16 _8154_set_tr_move_all(I16 TotalAxes, I16
    *AxisArray, F64 *DistA, F64 *StrVelA, F64
    *MaxVelA, F64 *TaccA, F64 *TdecA);
```

```

I16 _8154_set_ta_move_all(I16 TotalAx, I16
    *AxisArray, F64 *PosA, F64 *StrVelA, F64
    *MaxVelA, F64 *TaccA, F64 *TdecA);
I16 _8154_set_sr_move_all(I16 TotalAx, I16
    *AxisArray, F64 *DistA, F64 *StrVelA, F64
    *MaxVelA, F64 *TaccA, F64 *TdecA, F64
    *SVaccA, F64 *SVdecA);
I16 _8154_set_sa_move_all(I16 TotalAx, I16
    *AxisArray, F64 *PosA, F64 *StrVelA, F64
    *MaxVelA, F64 *TaccA, F64 *TdecA, F64
    *SVaccA, F64 *SVdecA);
I16 _8154_start_move_all(I16 FirstAxisNo);
I16 _8154_stop_move_all(I16 FirstAxisNo);

```

### Visual Basic (Windows XP/7/8.1)

```

B_8154_set_tr_move_all(ByVal TotalAxes As
    Integer, ByRef AxisArray As Integer, ByRef
    DistA As Double, ByRef StrVelA As Double,
    ByRef MaxVelA As Double, ByRef TaccA As
    Double, ByRef TdecA As Double) As Integer
B_8154_set_sa_move_all(ByVal TotalAxes As
    Integer, ByRef AxisArray As Integer, ByRef
    PosA As Double, ByRef StrVelA As Double,
    ByRef MaxVelA As Double, ByRef TaccA As
    Double, ByRef TdecA As Double, ByRef SVaccA
    As Double, ByRef SVdecA As Double) As
    Integer
B_8154_set_ta_move_all(ByVal TotalAxes As
    Integer, ByRef AxisArray As Integer, ByRef
    PosA As Double, ByRef StrVelA As Double,
    ByRef MaxVelA As Double, ByRef TaccA As
    Double, ByRef TdecA As Double) As Integer
B_8154_set_sr_move_all(ByVal TotalAxes As
    Integer, ByRef AxisArray As Integer, ByRef
    DistA As Double, ByRef StrVelA As Double,
    ByRef MaxVelA As Double, ByRef TaccA As
    Double, ByRef TdecA As Double, ByRef SVaccA
    As Double, ByRef SVdecA As Double) As
    Integer
B_8154_start_move_all(ByVal FirstAxisNo As
    Integer) As Integer
B_8154_stop_move_all(ByVal FirstAxisNo As
    Integer) As Integer

```

## @ Argument

**TotalAxes**: Number of axes for simultaneous motion

**\*AxisArray**: Specified axes number array designated to move.

**\*DistA**: Specified distance array in units of pulse

**\*StrVelA**: Starting velocity array in units of pulse per second

**\*MaxVelA**: Maximum velocity array in units of pulse per second

**\*TaccA**: Acceleration time array in units of seconds

**\*TdecA**: Deceleration time array in units of seconds

**\*PosA**: Specified position array in units of pulse

**\*SvaccA**: Specified velocity interval array in which S-curve acceleration is performed.

**\*SvdecA**: Specified velocity interval array in which S-curve deceleration is performed.

**FirstAxisNo**: The first element in AxisArray.

## B.19 General-Purpose DIO

### @ Name

`_8154_set_gpio_output` – Set digital output

`_8154_get_gpio_output` – Get digital output

`_8154_get_gpio_input` – Get digital input

`_8154_set_gpio_input_function` – Set the signal types for any digital inputs

### @ Description

`_8154_set_gpio_output`:

The PCIe-8154 has 4 digital output channels. By this function, user could control the digital outputs.

`_8154_get_gpio_output`:

This function is used to get the digital output status.

`_8154_get_gpio_input`:



PCIe-8154 has 4 digital input channels. By this function, user can get the digital input status.

#### **\_8154\_set\_gpio\_input\_function:**

PCIe-8154 has 4 digital input channels. By this function, user can set one of several input signals to any specific DI channels. Those signals include LTCn, SDn, PCSn, CLRn, EMG. (The index word n mean axis index)

### **@ Syntax**

#### **C/C++(Windows XP/7/8.1)**

```
I16 _8154_set_gpio_output(I16 card_id, I16
    DoValue );
I16 _8154_get_gpio_output(I16 card_id, I16 *
    DoValue );
I16 _8154_get_gpio_input(I16 card_id, I16 *
    DiValue );
I16 _8154_set_gpio_input_function(I16 card_id,
    I16 Channel, I16Select, I16 Logic);
```

#### **Visual Basic (Windows XP/7/8.1)**

```
B_8154_set_gpio_output(ByVal card_id As Integer,
    ByVal DoValue As Integer) As Integer
B_8154_get_gpio_output(ByVal card_id As Integer,
    DoValue As Integer) As Integer
B_8154_get_gpio_input(ByVal card_id As Integer,
    DiValue As Integer) As Integer
B_8154_set_gpio_input_function(ByVal card_id As
    Integer, ByVal Channel As Integer, ByVal
    Select As Integer, ByVal Logic As Integer)As
    Integer
```

### **@ Argument**

**card\_id:** Specify the PCIe-8154 card index. The card\_id could be decided by DIP switch (SW1) or depend on slot sequence. Please refer to \_8154\_initial().

**DoValue, \*DoValue:** Digital output value. Bit 0-3: D\_out 0-3.

**\*DiValue:** Digital input value, Bit 0-3: D\_in 0-3

**Channel:** Digital channel DI0 - DI3

**select:** signal types select

Value	Meaning
0	General DI (default)
1	LTC(active low)
2	SD(active low)
3	PCS(active low)
4	CLR (active low)
5	EMG (active low)

**Logic:** input signal logic

Value	Meaning
0	Not inverse (default)
1	Inverse

## B.20 Soft Limit

### @ Name

- `_8154_disable_soft_limit` – Disable soft limit function
- `_8154_enable_soft_limit` – Enable soft limit function
- `_8154_set_soft_limit` – Set soft limit

### @ Description

`_8154_disable_soft_limit:`

This function is used to disable the soft limit function.

`_8154_enable_soft_limit:`

This function is used to enable the soft limit function. Once enabled, the action of soft limit will be exactly the same as physical limit.

`_8154_set_soft_limit:`

This function is used to set the soft limit value.

**@ Syntax**

**C/C++(Windows XP/7/8.1)**

```
I16 _8154_disable_soft_limit(I16 AxisNo);
I16 _8154_enable_soft_limit(I16 AxisNo, I16
    Action);
I16 _8154_set_soft_limit(I16 AxisNo, I32
    PlusLimit, I32 MinusLimit);
```

**Visual Basic (Windows XP/7/8.1)**

```
B_8154_disable_soft_limit(ByVal AxisNo As
    Integer) As Integer
B_8154_enable_soft_limit(ByVal AxisNo As Integer,
    ByVal Action As Integer) As Integer
B_8154_set_soft_limit(ByVal AxisNo As Integer,
    ByVal PlusLimit As Long, ByVal MinusLimit As
    Long) As Integer
```

**@ Argument**

**AxisNo:** Axis number designated to move or stop.

card_id	Physical axis	AxisNo
0	0	0
	1	1
	2	2
	3	3
1	0	4
	1	5
	...	...

**Action:** The reacting method of soft limit

Value	Meaning
0	INT only
1	Immediately stop
2	slow down then stop

**PlusLimit:** Soft limit value, positive direction

**MinusLimit:** Soft limit value, negative direction

## B.21 Backlash Compensation / Vibration Suppression

### @ Name

`_8154_backlash_comp` – Set backlash corrective pulse for compensation

`_8154_suppress_vibration` – Set vibration suppressing timing

`_8154_set_fa_speed` – Set the FA speed

### @ Description

`_8154_backlash_comp`:

Whenever direction change occurs, the 8154 outputs backlash corrective pulses before sending commands. This function is used to set the compensation pulse numbers.

`_8154_suppress_vibration`:

This function is used to suppress vibration of mechanical systems by outputting a single pulse for negative direction and the single pulse for positive direction right after completion of command movement.

`_8154_set_fa_speed`:

This function is used to specify the low speed for backlash correction or slip correction. It also used as a reverse low speed for home return operation.

### @ Syntax

#### C/C++(Windows XP/7/8.1)

```
I16 _8154_backlash_comp(I16 AxisNo, I16
    CompPulse, I16 Mode);
I16 _8154_suppress_vibration(I16 AxisNo, U16
    ReverseTime,
    U16 ForwardTime);
I16 _8154_set_fa_speed(I16 AxisNo, F64 FA_Speed);
```

### Visual Basic (Windows XP/7/8.1)

```

B_8154_backlash_comps (ByVal AxisNo As Integer,
    ByVal CompPulse As Integer, ByVal Mode As
    Integer) As Integer
B_8154_suppress_vibration(ByVal AxisNo As
    Integer, ByVal ReverseTime As Integer, ByVal
    ForwardTime As Integer) As Integer
B_8154_set_fa_speed(ByVal AxisNo As Integer,
    ByVal FA_Speed As Double) As Integer
    
```

### @ Argument

**AxisNo:** Axis number designated to move or stop.

card_id	Physical axis	AxisNo
0	0	0
	1	1
	2	2
	3	3
1	0	4
	1	5
	...	...

**CompPulse:** Specified number of corrective pulses, 12 bit

**Mode:**

Value	Meaning
0	Turns off
1	enable backlash compensation
2	Slip correction

**ReverseTime:** Specified Reverse Time, 0 - 65535, unit 1.6 us

**ForwardTime:** Specified Forward Time, 0 - 65535, unit 1.6 us

**FA\_Speed:** fa speed (unit: pulse/sec)

## B.22 Speed Profile Calculation

### @ Name

`_8154_get_tr_move_profile` – Get the relative trapezoidal speed profile

`_8154_get_ta_move_profile` – Get the absolute trapezoidal speed profile

`_8154_get_sr_move_profile` – Get the relative S-curve speed profile

`_8154_get_sa_move_profile` – Get the absolute S-curve speed profile

### @ Description

`_8154_get_tr_move_profile:`

This function is used to get the relative trapezoidal speed profiles. By this function, user can get the actual speed profile before running.

`_8154_get_ta_move_profile:`

This function is used to get the absolute trapezoidal speed profiles. By this function, user can get the actual speed profile before running.

`_8154_get_sr_move_profile:`

This function is used to get the relative S-curve speed profiles. By this function, user can get the actual speed profile before running.

`_8154_get_sa_move_profile:`

This function is used to get the absolute S-curve speed profiles. By this function user can get the actual speed profile before running.

### @ Syntax

**C/C++(Windows XP/7/8.1)**

```
I16 _8154_get_tr_move_profile(I16 AxisNo, F64  
Dist, F64 StrVel, F64 MaxVel, F64 Tacc, F64
```

```

    Tdec, F64 *pStrVel, F64 *pMaxVel, F64
    *pTacc, F64 *pTdec, F64 *pTconst );
I16 _8154_get_ta_move_profile(I16 AxisNo, F64
    Pos, F64 StrVel, F64 MaxVel, F64 Tacc, F64
    Tdec, F64 *pStrVel, F64 *pMaxVel, F64
    *pTacc, F64 *pTdec, F64 *pTconst );
I16 _8154_get_sr_move_profile(I16 AxisNo, F64
    Dist, F64 StrVel, F64 MaxVel, F64 Tacc, F64
    Tdec, F64 SVacc, F64 SVdec, F64 *pStrVel, F64
    *pMaxVel, F64 *pTacc, F64 *pTdec, F64
    *pSVacc, F64 *pSVdec, F64 *pTconst);
I16 _8154_get_sa_move_profile(I16 AxisNo, F64
    Pos, F64 StrVel, F64 MaxVel, F64 Tacc, F64
    Tdec, F64 SVacc, F64 SVdec, F64 *pStrVel, F64
    *pMaxVel, F64 *pTacc, F64 *pTdec, F64
    *pSVacc, F64 *pSVdec, F64 *pTconst);

```

### Visual Basic (Windows XP/7/8.1)

```

B_8154_get_tr_move_profile(ByVal AxisNo As
    Integer, ByVal Dist As Double, ByVal StrVel
    As Double, ByVal MaxVel As Double, ByVal
    Tacc As Double, ByVal Tdec As Double, ByRef
    pStrVel As Double, ByRef pMaxVel As Double,
    ByRef pTacc As Double, ByRef pTdec As
    Double, ByRef pTconst As Double) As Integer
B_8154_get_ta_move_profile(ByVal AxisNo As
    Integer, ByVal Pos As Double, ByVal StrVel
    As Double, ByVal MaxVel As Double, ByVal
    Tacc As Double, ByVal Tdec As Double, ByRef
    pStrVel As Double, ByRef pMaxVel As Double,
    ByRef pTacc As Double, ByRef pTdec As
    Double, ByRef pTconst As Double) As Integer
B_8154_get_sr_move_profile(ByVal AxisNo As
    Integer, ByVal Dist As Double, ByVal StrVel
    As Double, ByVal MaxVel As Double, ByVal
    Tacc As Double, ByVal Tdec As Double, ByVal
    SVacc As Double, ByVal SVdec As Double,
    ByRef pStrVel As Double, ByRef pMaxVel As
    Double, ByRef pTacc As Double, ByRef pTdec
    As Double, ByRef pSVacc As Double, ByRef
    pSVdec As Double, ByRef pTconst As Double)
    As Integer
B_8154_get_sa_move_profile(ByVal AxisNo As
    Integer, ByVal Pos As Double, ByVal StrVel

```

As Double, ByVal MaxVel As Double, ByVal Tacc As Double, ByVal Tdec As Double, ByVal SVacc As Double, ByVal SVdec As Double, ByVal pStrVel As Double, ByVal pMaxVel As Double, ByVal pTacc As Double, ByVal pTdec As Double, ByVal pSVacc As Double, ByVal pSVdec As Double, ByVal pTconst As Double) As Integer

## @ Argument

**AxisNo:** Axis number designated to move or stop.

card_id	Physical axis	AxisNo
0	0	0
	1	1
	2	2
	3	3
1	0	4
	1	5
	...	...

**Dist:** Specified relative distance (unit: pulse)

**Pos:** Specified absolute position (unit: pulse)

**strVel:** Starting velocity (unit: pulse/sec)

**MaxVel:** Maximum velocity (unit: pulse/sec)

**Tacc:** time for acceleration (unit: sec)

**Tdec:** time for deceleration (unit: sec)

**svacc:** S-curve region during acceleration (unit: pulse/sec)

Note: SVacc = 0, for pure S-Curve. For more details, see section 4.2.4



**svdec:** S-curve region during deceleration (unit: pulse/sec)

Note: SVdec = 0, for pure S-Curve. For more details, see section 4.2.4

\***pStrVel:** Starting velocity by calculation

\***pMaxVel:** Maximum velocity by calculation

\***pTacc:** Acceleration time by calculation

\***pTdec:** Deceleration time by calculation

\***pSVacc:** S-curve region during acceleration by calculation

\***pSVdec:** S-curve region during deceleration by calculation

\***pTconst:** constant speed time(maximum speed)

## B.23 Extended General Purpose TTL Input/Output

### @ Name

`_8154_set_gpio_output_ex` – Set digital output

`_8154_get_gpio_output_ex` – Get digital output

`_8154_get_gpio_input_ex` – Get digital input

`_8154_set_gpio_output_ex_CH` – Set digital output by channel

`_8154_get_gpio_output_ex_CH` – Get digital output by channel

`_8154_get_gpio_input_ex_CH` – Get digital input by channel

### @ Description

`_8154_set_gpio_output_ex()`:

Set the on\_off status for digital output pin.

`_8154_get_gpio_output_ex()`:

Read on\_off status of all digital output pins.

`_8154_get_gpio_input_ex()`:

Read on\_off status of all digital input pins.

`_8154_set_gpio_output_ex_CH()`:

Set the on\_off status for digital output pins by channel.

`_8154_get_gpio_output_ex_CH()`:

Read on\_off status of all digital output pins by channel.

`_8154_get_gpio_input_ex_CH()`:

Read on\_off status of all digital input pins by channel.

## @ Syntax

### C/C++(Windows XP/7/8.1)

```
I16 _8154_set_gpio_output_ex(I16 CardNo, U16
    DoValue);
I16 _8154_get_gpio_output_ex(I16 CardNo, U16
    *DoValue );
I16 _8154_get_gpio_input_ex(I16 CardNo, U16
    *DiValue );
I16 _8154_set_gpio_output_ex_CH(I16 CardNo, U16
    Channel, U16 Value );
I16 _8154_get_gpio_output_ex_CH(I16 CardNo, U16
    Channel, U16 *Value );
I16 _8154_get_gpio_input_ex_CH(I16 CardNo, U16
    Channel, U16 *Value );
```

### Visual Basic (Windows XP/7/8.1)

```
B_8154_set_gpio_output_ex(ByVal CardNo As
    Integer, ByVal DoValue As Integer) As
    Integer
B_8154_get_gpio_output_ex(ByVal CardNo As
    Integer, DoValue As Integer) As Integer
B_8154_get_gpio_input_ex(ByVal CardNo As Integer,
    DiValue As Integer) As Integer
B_8154_set_gpio_output_ex_CH(ByVal CardNo As
    Integer, ByVal Channel As Integer, ByVal
    Value As Integer) As Integer
B_8154_get_gpio_output_ex_CH(ByVal CardNo As
    Integer, ByVal Channel As Integer, Value As
    Integer) As Integer
B_8154_get_gpio_input_ex_CH(ByVal CardNo As
    Integer, ByVal Channel As Integer, Value As
    Integer) As Integer
```

## @ Argument

**CardNo:** Axis number designated.

**Channel1:** Designated channel number 0 to 15.

**DoValue:** All output values.

**DiValue:** All input values.

**value:** On-Off value for output or input in specific channel where Value=0 or 1

## B.24 Return Code

The return error code is defined in "8154\_err.h". The meaning is described in following table.

Code	Meaning
0	No error
-10000	Error Card number
-10001	Error operation system version
-10002	Error card's ID conflict
-10300	Error other process exist
-10301	Error card not found
-10302	Error Open driver failed
-10303	Error ID mapping failed
-10304	Error trigger channel
-10305	Error trigger type
-10306	Error event already enabled
-10307	Error event not enable yet
-10308	Error on board FIFO full
-10309	Error unknown command type
-10310	Error unknown chip type
-10311	Error card not initial
-10312	Error position out of range
-10313	Error motion busy
-10314	Error speed error
-10315	Error slow down point
-10316	Error axis range error

<b>Code</b>	<b>Meaning</b>
-10317	Error compare parameter error
-10318	Error compare method
-10319	Error axis already stop
-10320	Error axis INT wait failed
-10321	Error user code write failed
-10322	Error array size exceed
-10323	Error factor number
-10324	Error enable range
-10325	Error auto accelerate time
-10326	Error dwell time
-10327	Error dwell distance
-10328	Error new position
-10329	Error motion not in running
-10330	Error velocity change time
-10331	Error speed target
-10332	Error velocity percent
-10333	Error position change backward
-10334	Error counter number
-10335	Error gpio input function parameter
-10336	Error channel number
-10337	Error ERC mode
-10338	Error security code

## Appendix C Connection Example

### C.1 General Description of Wiring

The following illustrates an exemplary integration of the PCIe-8154 and DIN-814M-J3A.

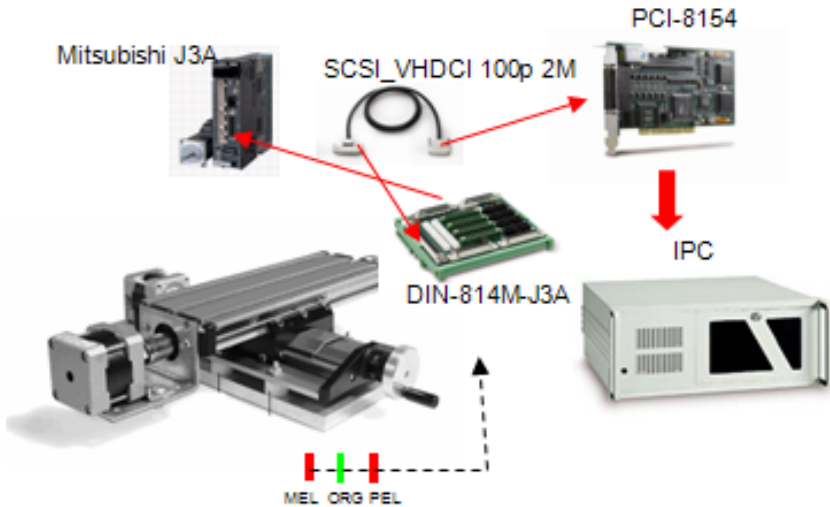

### C.2 Terminal Board User Guide

Please refer to the individual terminal board's User Guide. Supported terminal boards are as follows:

Mitsubishi J2 Super	DIN-814M
Mitsubishi J3A	DIN-814M-J3A
Yaskawa Sigma II	DIN-814Y
Panasonic MINAS A4	DIN-814P-A4

This page intentionally left blank.

# Important Safety Instructions

For user safety, please read and follow all **instructions**, **WARNINGS**, **CAUTIONS**, and **NOTES** marked in this manual and on the associated equipment before handling/operating the equipment.

- ▶ Read these safety instructions carefully.
- ▶ Keep this user's manual for future reference.
- ▶ Read the specifications section of this manual for detailed information on the operating environment of this equipment.
- ▶ When installing/mounting or uninstalling/removing equipment:
  - ▷ Turn off power and unplug any power cords/cables.
- ▶ To avoid electrical shock and/or damage to equipment:
  - ▷ Keep equipment away from water or liquid sources;
  - ▷ Keep equipment away from high heat or high humidity;
  - ▷ Keep equipment properly ventilated (do not block or cover ventilation openings);
  - ▷ Make sure to use recommended voltage and power source settings;
  - ▷ Always install and operate equipment near an easily accessible electrical socket-outlet;
  - ▷ Secure the power cord (do not place any object on/over the power cord);
  - ▷ Only install/attach and operate equipment on stable surfaces and/or recommended mountings; and,
  - ▷ If the equipment will not be used for long periods of time, turn off and unplug the equipment from its power source.

- ▶ Never attempt to fix the equipment. Equipment should only be serviced by qualified personnel.
- ▶ A Lithium-type battery may be provided for uninterrupted, backup or emergency power.



Risk of explosion if battery is replaced with an incorrect type; please dispose of used batteries appropriately.

- ▶ Equipment must be serviced by authorized technicians when:
  - ▷ The power cord or plug is damaged;
  - ▷ Liquid has penetrated the equipment;
  - ▷ It has been exposed to high humidity/moisture;
  - ▷ It is not functioning or does not function according to the user's manual;
  - ▷ It has been dropped and/or damaged; and/or,
  - ▷ It has an obvious sign of breakage.

Please pay strict attention to all warnings and advisories appearing on the device, to avoid injury or damage.

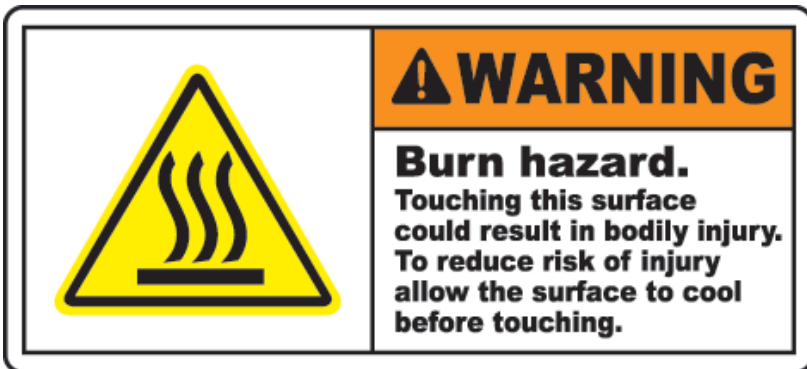



# Getting Service

Contact us should you require any service or assistance.

## **ADLINK Technology, Inc.**

Address: 9F, No.166 Jian Yi Road, Zhonghe District  
New Taipei City 235, Taiwan  
新北市中和區建一路 166 號 9 樓  
Tel: +886-2-8226-5877  
Fax: +886-2-8226-5717  
Email: [service@adlinktech.com](mailto:service@adlinktech.com)

## **Ampro ADLINK Technology, Inc.**

Address: 5215 Hellyer Avenue, #110  
San Jose, CA 95138, USA  
Tel: +1-408-360-0200  
Toll Free: +1-800-966-5200 (USA only)  
Fax: +1-408-360-0222  
Email: [info@adlinktech.com](mailto:info@adlinktech.com)

## **ADLINK Technology (China) Co., Ltd.**

Address: 上海市浦东新区张江高科技园区芳春路 300 号 (201203)  
300 Fang Chun Rd., Zhangjiang Hi-Tech Park  
Pudong New Area, Shanghai, 201203 China  
Tel: +86-21-5132-8988  
Fax: +86-21-5132-3588  
Email: [market@adlinktech.com](mailto:market@adlinktech.com)

## **ADLINK Technology Beijing**

Address: 北京市海淀区上地东路 1 号盈创动力大厦 E 座 801 室(100085)  
Rm. 801, Power Creative E, No. 1 Shang Di East Rd.  
Beijing, 100085 China  
Tel: +86-10-5885-8666  
Fax: +86-10-5885-8626  
Email: [market@adlinktech.com](mailto:market@adlinktech.com)

## **ADLINK Technology Shenzhen**

Address: 深圳市南山区科技园南区高新南七道 数字技术园  
A1 栋 2 楼 C 区 (518057)  
2F, C Block, Bldg. A1, Cyber-Tech Zone, Gao Xin Ave. Sec. 7  
High-Tech Industrial Park S., Shenzhen, 518054 China  
Tel: +86-755-2643-4858  
Fax: +86-755-2664-6353  
Email: [market@adlinktech.com](mailto:market@adlinktech.com)

## **LiPPERT ADLINK Technology GmbH**

Address: Hans-Thoma-Strasse 11, D-68163  
Mannheim, Germany  
Tel: +49-621-43214-0  
Fax: +49-621 43214-30  
Email: [emea@adlinktech.com](mailto:emea@adlinktech.com)

**ADLINK Technology, Inc. (French Liaison Office)**

Address: 6 allée de Londres, Immeuble Ceylan  
91940 Les Ulis, France  
Tel: +33 (0) 1 60 12 35 66  
Fax: +33 (0) 1 60 12 35 66  
Email: france@adlinktech.com

**ADLINK Technology Japan Corporation**

Address: 〒101-0045 東京都千代田区神田鍛冶町 3-7-4  
神田 374 ビル 4F  
KANADA374 Bldg. 4F, 3-7-4 Kanda Kajicho,  
Chiyoda-ku, Tokyo 101-0045, Japan  
Tel: +81-3-4455-3722  
Fax: +81-3-5209-6013  
Email: japan@adlinktech.com

**ADLINK Technology, Inc. (Korean Liaison Office)**

Address: 137-881 서울시 서초구 서초대로 326, 802 (서초동, 모인터빌딩)  
802, Mointer B/D, 326 Seocho-daero, Seocho-Gu,  
Seoul 137-881, Korea  
Tel: +82-2-2057-0565  
Fax: +82-2-2057-0563  
Email: korea@adlinktech.com

**ADLINK Technology Singapore Pte. Ltd.**

Address: 84 Genting Lane #07-02A, Cityneon Design Centre  
Singapore 349584  
Tel: +65-6844-2261  
Fax: +65-6844-2263  
Email: singapore@adlinktech.com

**ADLINK Technology Singapore Pte. Ltd. (Indian Liaison Office)**

Address: #50-56, First Floor, Spearhead Towers  
Margosa Main Road (between 16th/17th Cross)  
Malleswaram, Bangalore - 560 055, India  
Tel: +91-80-65605817, +91-80-42246107  
Fax: +91-80-23464606  
Email: india@adlinktech.com

**ADLINK Technology, Inc. (Israeli Liaison Office)**

Address: 27 Maskit St., Corex Building  
PO Box 12777  
Herzliya 4673300, Israel  
Tel: +972-54-632-5251  
Fax: +972-77-208-0230  
Email: israel@adlinktech.com

**ADLINK Technology, Inc. (UK Liaison Office)**

Tel: +44 774 010 59 65  
Email: UK@adlinktech.com