

PCI-8213/8214
4-Port / 2-Port PCI Ethernet Controller
User' s Guide



Recycled Paper

©Copyright 2002 ADLINK Technology Inc.

All Rights Reserved.

Manual Rev. 1.0: June 2002

Part No : 50-13028-110

The information in this document is subject to change without prior notice in order to improve reliability, design and function and does not represent a commitment on the part of the manufacturer.

In no event will the manufacturer be liable for direct, indirect, special, incidental, or consequential damages arising out of the use or inability to use the product or documentation, even if advised of the possibility of such damages.

This document contains proprietary information protected by copyright. All rights are reserved. No part of this manual may be reproduced by any mechanical, electronic, or other means in any form without prior written permission of the manufacturer.

Trademarks

Other product names mentioned herein are used for identification purposes only and may be trademarks and/or registered trademarks of their respective companies.

Getting service from ADLINK

Customer Satisfaction is always the most important thing for ADLINK Tech Inc. If you need any help or service, please contact us and get it.

ADLINK Technology Inc.			
Web Site	http://www.adlinktech.com		
Sales & Service	service@adlinktech.com		
Technical Support	NuDAQ	nudaq@adlinktech.com	
	Automation	automation@adlinktech.com	
	NuIPC	nuipc@adlinktech.com	
	NuPRO / EBC	nupro@adlinktech.com	
TEL	+886-2-82265877	FAX	+886-2-82265717
Address	9F, No. 166, Jian Yi Road, Chungho City, Taipei, 235 Taiwan		

Please inform or FAX us of your detailed information for a prompt, satisfactory and constant service.

Detailed Company Information			
Company/Organization			
Contact Person			
E-mail Address			
Address			
Country			
TEL		FAX	
Web Site			
Questions			
Product Model			
Environment to Use	<input type="checkbox"/> OS _____ <input type="checkbox"/> Computer _____ <input type="checkbox"/> M/B: _____ <input type="checkbox"/> CPU: _____ <input type="checkbox"/> Chipset: _____ <input type="checkbox"/> Bios: _____ <input type="checkbox"/> Video Card: _____ <input type="checkbox"/> Network Interface Card: _____ <input type="checkbox"/> Other: _____		
Challenge Description			
Suggestions to ADLINK			

Table of Contents

How to use this guide	iii
Chapter 1 Introduction.....	1
1.1 Ethernet	1
1.1.1 <i>Fast Ethernet</i>	1
1.1.2 <i>Connect the Network Cable</i>	2
1.1.3 <i>Pin-definition of RJ45 Connector</i>	2
1.2 Drivers on ADLINK CD.....	3
Chapter 2 PCI-8213	4
2.1 Introduction	4
2.2 Specifications	4
2.3 Installation.....	6
2.4 Jumper Setting	6
2.5 PCI-8213 Front Panel	7
2.6 Extra Display Connector.....	8
2.7 PXE Function	9
Chapter 3 PCI-8214	10
3.1 Introduction	10
3.2 Specifications	10
3.3 Installation.....	12
3.4 Jumper Setting	13
3.5 PCI-8214 Front Panel	13
3.6 Extra Display Connector.....	14
3.7 PXE Function	15
Chapter 4 82559 Driver Installation	16
4.1 Software and Drivers Support	16
4.2 Driver Installation on Windows 2000	17
4.3 Driver Installation on Windows 98 (SE & ME)	18
4.4 Driver Installation on Windows NT	19
4.5 Driver Installation on Red Hat Linux	20
Chapter 5 Bypass and WDT	21
5.1 Bypass Operation	21
5.1.1 <i>Block Diagram</i>	21

5.1.2	<i>Communication States</i>	22
5.1.3	<i>WDT Test Utilities</i>	22
5.1.4	<i>WDT and State Change</i>	22
5.2	WDT control	25
5.2.1	<i>WDT control</i>	25
5.2.2	<i>WDT Time-out Value</i>	25
5.2.3	<i>Programming information of the WDT</i>	26
5.3	DOS Test Utility.....	28
5.4	WDT DLL for Windows NT & 2000	28
5.5	WDT Library for Linux	29
	Warranty Policy	31

How to use this guide

This manual is to help you use PCI-821X series modules. The briefs contents are as following:

Chapter 1, Introduction gives an overview of the Ethernet. The detail information of each product is list in Chapter 2 to Chapter 4.

Chapter 2, PCI-8213 gives detail information of this product.

Chapter 3, PCI-8214 gives detail information of this product.

Chapter 4, 82559 Driver Installation gives detail information of NIC driver installation for the PCI-8213 and PCI-8214 products.

Chapter 5, WDT and Bypass gives the details of the bypass function and how to control the WDT.



Introduction

This users manual is used for PCI-8213 and PCI-8214 products based on standard universal PCI short card. The products include:

PCI-8213: 4 ports of 10 Base-T / 100 Base-TX Fast Ethernet

PCI-8214: 2 ports of 10 Base-T / 100 Base-TX Fast Ethernet

Please refer the Chapter 2 and Chapter 3 for detail information of those products. In the following sections, we introduce the basic information about Ethernet.

1.1 Ethernet

1.1.1 Fast Ethernet

Fast Ethernet is a network technology specified by IEEE Standard 802.3u. It extends the traditional 10Mbps Ethernet technology to achieve 100Mbps transmission and reception, while retaining the same CSMA/CA Ethernet protocol. Thus while Fast Ethernet provides a tenfold increase in network capacity, it is completely compatible with traditional 10Mbps Ethernet network facilities.

The compatibility is the key to easily and efficiently upgrade to 100Mbps in your network areas while greater bandwidth is needed. Upgrading selected areas to Fast Ethernet does not require hardware or software changes in network areas where traditional 10Mbps Ethernet is providing good service. For upgrading existing Ethernet installations to 100Mbps, and especially for selectively upgrading areas needing upgrade, Fast Ethernet is the clear choice in terms of cost-effectiveness, as well as convenience and smoothness in transition.

Fast Ethernet comprises of two subtypes: 100Base-T4 and 100Base-TX.

100Base-T4 Fast Ethernet can utilize existing Category 5 cabling, but doesn't provide full duplex operation. Full duplex 100Base-TX operation allows simultaneous transmission and reception, both at 100Mbps, thus providing service potentially equal to 200Mbps half-duplex service.

1.1.2 Connect the Network Cable

Category 5 UTP cable qualifies for both, the Fast Ethernet and Ethernet, cabling rules. The maximum length of any single cable run between any station and its supporting Hub is 100 meters. The maximum length of a cable joining two Hubs is 10m in general, but is 100m when both Hubs qualify as Ethernet class 2 Repeaters. However, these cables run may need to be shorter than the given individual maximum lengths because their maximum aggregated cable run between any two stations is 205m.

Connecting for 100Mbps Ethernet

Category 5 UTP cable is required for fast Ethernet operation. The maximum cable run between the PCI-8213/8214 and the supporting Hub is 100 meters. The cable must be straight (not a crossover cable) with an RJ-45 plug at each end. Make the network connection by plugging one end of the cable into the RJ-45 jack of the PCI-8213/8214, and the other end into a port of the supporting Hub.

Connecting for 10Mbps Ethernet

Category 3, Category 4, and Category 5 UTP cable, as well as EIA/TIA-568 100-ohm STP cable, all qualify under Ethernet cabling rules. The maximum cable run between the PCI-8213/8214 and the supporting Hub is 100 meters. The cable must be straight (not a crossover cable) with RJ-45 connector at each end. To connect the network is via plugging one end of the cable into the RJ-45 jack of the PCI-8213/8214 and the other end into a port of the supporting Hub.

1.1.3 Pin-definition of RJ45 Connector

This connector is for the 10/100Mbps Ethernet capability of the Ethernet card. The figure below shows the pin out assignments of this connector and its corresponding input jack.

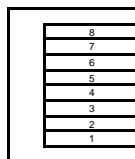

RJ45

Pin#1: TD+	Pin#5: NC
Pin#2: TD-	Pin#6: RD-
Pin#3: RD+	Pin#7: NC
Pin#4: NC	Pin#8: NC

1.2 Drivers on ADLINK CD

To install the drivers and utility for the PCI-8213 / 8214 product, please refer the detail installation information from the Chapter 4. We provide the basic information in this manual, however, for more detail installation information, such as non-Windows OS installation, please refer the extensive explanation inside the ADLINK CD. We put the LAN driver in the following directory:

LAN driver of 82559 Chip\CHIPDRV\LAN\100pdisk

Due to the Windows NT is a none plug-and-play OS, we remind you some tips for installing the Windows NT here:

1. We suggest that installing the newest update version of service pack after installing LAN driver.
2. We suggest installing any other driver before installing service pack. Please make sure your service pack does support AGP, thus service pack 6.0a is recommended.
3. Once your NT booting procedure is warning, please check the Event Viewer to make sure what is the real problem. If Windows NT is showing any warning messages which could not be solved, we suggest to re-install Windows NT, and install all drivers in different sequence again.



PCI-8213

2.1 Introduction

PCI-8213 is the high performance 4-port Ethernet card which complies with the PCI standards. It integrates 4 Intel 82559 single chip Ethernet controllers and 1 Intel 21154 single chip PCI-to-PCI bridge.

2.2 Specifications

- ◆ **Bus architecture:**
 - Standard PCI Universal bus
 - Fully complied with PCI Rev2.2
 - Fully support 32/64-bit and 33/66MHz
- ◆ **Ethernet I/F:**
 - Intel 82559 Ethernet Controller
 - Complied with PCI V2.2, IEEE802.3, IEEE802.3u
 - True 32-bit PCI bus master
 - Full duplex support
 - 10 Base-T/ 100 Base-TX support
 - 100Mbps Fast Ethernet or 10Mbps data transfer, selected via auto-negotiation
 - Support INTEL Preboot Execution Environment (PXE) for remote boot
 - Two LED indicators for each channel :10 Mbps/100Mbps and Link / Active
 - Drivers support: DOS, Windows 98 SE, Windows ME, Windows NT, Windows 2000, Linux Red Hat
- ◆ **Power requirements: 5V or 3.3V @ 2A (max.)**
- ◆ **Compliant Standards:**

- CE Test According to:
 - EMI Test : European Standard EN 55022 Class B
 - Harmonic Test : European Standard EN 61 000-3-2
 - Voltage fluctuations Test : European Standard EN 61 000-3-3
 - EMS Test : European Standard EN 50 082-1:1997
- FCC Test According to : Standard for Methods of Measurement
ANSI C63.4 – 1992
Test in Compliance with CISPR PUB. 22 and FCC Part 15
- ◆ **Environment:**
 - Operating Temperature: 0 to 60°C
 - Storage Temperature: -20 to 80°C
 - Humidity: 10%~90% non condensing
- ◆ **Dimension:**
 - Standard PCI half-sized card form factor

2.3 Installation

After unpacking the box, please check if the package contains the following items. If you discover any damage or any item missing, please contact with your dealer.

PCI-8213: Standard PCI short card board
ADLINK CD
This manual

You may follow the following steps to install this card into your system.

1. Read this Manual
2. Check the PCB if there is any damage on it
3. Setup the jumper if necessary
4. Install the board into your system
5. Prepare to install the software drivers, you may need to prepare a floppy diskette to pre-copy the drivers from ADLINK CD if you install drivers by a FDD.
6. Install driver
7. Connect the Ethernet cable to check the board function.

2.4 Jumper Setting

The PCI-8213 supports remote boot via PREBOOT EXECUTION ENVIRONMENT (PXE) function by installing a boot ROM. The boot ROM is default installation but disable. The only jumper on the PCI-8213 is used to enable or disable the boot ROM.

JP2: Boot Rom enable & disable setting

	Default Setting	
JP2	Disable BOOT ROM	Enable BOOT ROM
Jumper Pin No.	1 - 2	2 - 3

2.5 PCI-8213 Front Panel

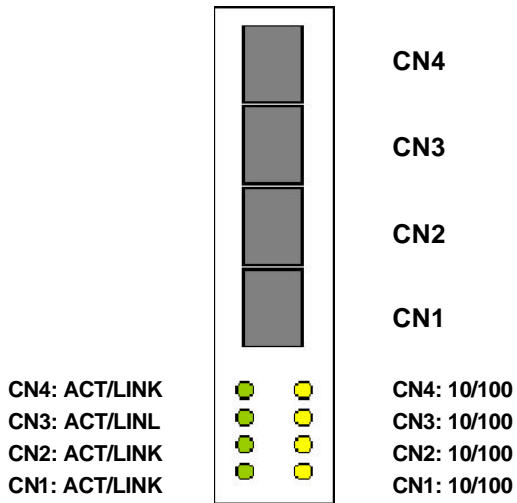

Figure 2.5.1 PCI-8213 Front Panel

CN1~4: RJ45 Connector
ACT: LAN active
LINK: LAN Link
10/100: 10/100 Mbps

2.6 Extra Display Connector

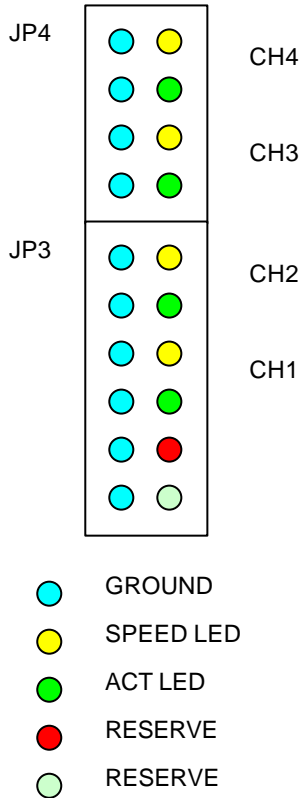

Figure 2.6.1 Extra Display Connector Pin Assignment

2.7 PXE Function

The PCI-8213 supports one channel (CN1) remote boot via PREBOOT EXECUTION ENVIRONMENT (PXE) function. The user should enable the system BIOS' s **Boot From LAN First** item. When POST (power-on self-test) of the system BIOS finished, press **Ctrl+S** Into INTEL Boot Agent Setup Program. There are seven items as following.

Boot Protocol:	PXE (RPL)
PnP/BEVBoot:	Disable (Enable)
Default Boot:	Network (Local)
Local Boot:	Enable (Disable)
Prompt time	5 (2,3,8)
Setup Message:	Disable (Enable)
Power Mgmt:	ACPI (APM)

3

PCI-8214

3.1 Introduction

PCI-8214 is the high performance 2-port Ethernet card, which complies with the PCI standards. It integrates 2 Intel 82559 single chip Ethernet controllers and one Intel 21154 single chip PCI-to-PCI bridge. PCI-8214 has the ability of connecting two channels while the system is halted or software is down when WDT function is active.

3.2 Specifications

- ◆ **Bus architecture:**
 - Standard PCI Universal bus
 - Fully complied with PCI Rev2.2
 - Fully support 32/64-bit and 33/66MHz
- ◆ **Ethernet I/F:**
 - Intel 82559 Ethernet Controller
 - Complied with PCI V2.2, IEEE802.3, IEEE802.3u
 - True 32-bit PCI bus master
 - Full duplex support
 - 10 Base-T/ 100 Base-TX support
 - 100Mbps Fast Ethernet or 10Mbps data transfer, selected via auto-negotiation
 - Support INTEL Preboot Execution Environment (PXE) for remote boot
 - Two LED indicators for each channel :10 Mbps/100Mbps and Link / Active
 - Drivers support: DOS, Windows 98 SE, Windows ME, Windows NT, Windows2000, Linux

◆ **Power:**

- Power Requirement: 5V or 3.3V @ 1.2A (maximum)

◆ **Compliant Standards:**

- CE Test According to:
 - EMI Test: European Standard EN 55022 Class B
 - Harmonic Test: European Standard EN 61 000-3-2
 - Voltage fluctuations Test: European Standard EN 61 000-3-3
 - EMS Test: European Standard EN 50 082-1:1997
- FCC Test According to: Standard for Methods of Measurement
ANSI C63.4 – 1992
- Test in Compliance with CISPR PUB. 22 and FCC Part 15

◆ **Environment:**

- Operating Temperature: 0 to 60°C
- Storage Temperature: -20 to 80°C
- Humidity: 10%~90% non condensing

◆ **Dimension:**

- Standard PCI half-sized card form factor

3.3 Installation

After unpacking the box, please check if the package contains the following items. If you discover any damage or any item missing, please contact with your dealer.

PCI-8214 card
ADLINK CD
This manual

You may follow the following steps to install this card into your system.

1. Read this Manual
2. Check the PCB if there is any damage on it
3. Setup the jumper if necessary
4. Install the board into your system
5. Prepare to install the software drivers, you may need to prepare a floppy diskette to pre-copy the drivers from ADLINK CD if you install drivers by a FDD.
6. Install driver
7. Connect the Ethernet cable to check the board function.
8. Setup WDT function program when bypass ability is needed. WDT program provided is only used in NT environment.

3.4 Jumper Setting

The PCI-8214 supports remote boot via PREBOOT EXECUTION ENVIRONMENT (PXE) function by installing a boot ROM. The boot ROM is default installation but disable. The only jumper on the PCI-8214 is used to enable or disable the boot ROM.

JP2: Boot Rom enable & disable setting

 Default Setting		
JP2	Disable BOOT ROM	Enable BOOT ROM
Jumper Pin No.	1 - 2	2 - 3

3.5 PCI-8214 Front Panel

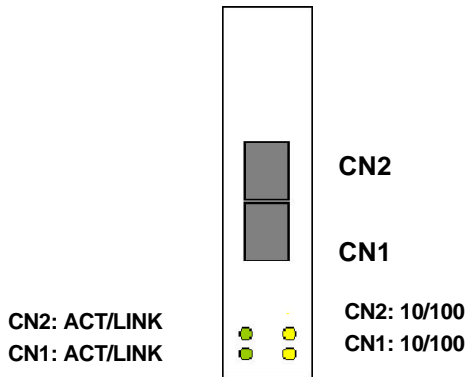

Figure 2.5.1 Front Panel of PCI-8214

LED	Status	Description
10/100	Blinking	Bypass is active
	Light	100 Mbps
	Dark	10 Mbps
ACT	Blinking	Data transmission is active
	Light	LAN Link
	Dark	LAN disconnect

3.6 Extra Display Connector

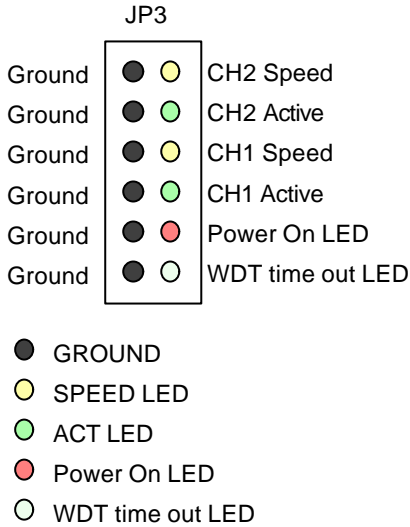

Fig 3.6.1 Extra Display Connector Pin Assignment

Pins	Signal Level	Meaning
Speed	High	100 Mbps
	Low	10 Mbps
ACT	Blinking	Data transmission is active
	Light	LAN Link
	Low	LAN Disconnect
Power On	High	5V Power on
WDT time out	High	Normal mode or Power on status
	Low	Bypass mode

3.7 PXE Function

The PCI-8214 supports one channel (CN1) remote boot via PREBOOT EXECUTION ENVIRONMENT (PXE) function. The user should enable the system BIOS' s **Boot From LAN First** item. When POST (power-on self-test) of the system BIOS finished, press Ctrl+S Into INTEL Boot Agent Setup Program. There are seven items as following.

Boot Protocol:	PXE (RPL)
PnP/BEVBoot:	Disable (Enable)
Default Boot:	Network (Local)
Local Boot:	Enable (Disable)
Prompt time	5 (2,3,8)
Setup Message:	Disable (Enable)
Power Mgmt:	ACPI (APM)

4

82559 Driver Installation

This chapter describes LAN driver installation for the onboard Ethernet controller **Intel 82559**. The relative drivers are under the following ADLINK CD directory: **X:\CHIPDRV\LAN\100pdisk**, where X: is the location of the CD-ROM drive.

4.1 Software and Drivers Support

The 82559 drivers support the following OS or platforms:

Windows 95, Windows 98, Windows 2000, Windows NT
Novell Netware, DOS Setup for Novell NetWare DOS
UNIX, OS2, Linux

All the above drivers are included in the ADLINK CD. In the following section, we will describe the driver installation for Windows 98, Windows 2000, Windows NT and Linux. For the driver installation of other OS, please refer the read-me file inside the CD.

4.2 Driver Installation on Windows 2000

The Windows 2000 will install LAN driver automatically. We recommend you to manually install the most updating LAN driver from ADLINK CD to ensure the compatibility. After installing the Windows 2000, please update the driver by the following steps.

1. Boot Windows 2000, Click **Start**. Select **Settings** then double-click the **Control Panel**.
2. Double-click **System** icon, click **Hardware** tab, click **Device Manager** button.
3. Double-click Network Adapters entry, Double-click the Intel® PRO/100+ Management Adapter entry.
4. Click **Driver** tab, then click **Update Driver..**button.
5. An Update Device Driver Wizard window will pop up, click **Next>**.
6. Select **Display a list of ...** and click **Next>**. The next window may show a list of hardware models.
7. Insert the CD and click **Have Disk**.
8. Browse the 82559 driver in the following path:
X:\CHIPDRV\LAN\100pdisk, highlight **oemsetup.inf**, click **Open**, then click **OK**.
9. Highlight the model: **Intel®PRO/100+ Management Adapter**, then click **NEXT>**. An Update Driver Warning window may pop up, click **Yes** to continue.
10. Click **NEXT>** button, the Wizard summary window will appear.
11. Click **Finish** button, then click **CLOSE** button.

4.3 Driver Installation on Windows 98 (SE & ME)

The Windows 98 will install the LAN driver automatically. We recommend you to manually update the LAN driver from ADLINK CD to ensure the compatibility. After setuping Windows 98, please update the driver through the following steps.

1. Boot Windows 98, Click **Start**. Select **Settings** then double-click the **Control Panel**.
2. Double-click on the **System** icon, click on the **Device Manager** tab.
3. Either Double-click on the **Network Adapters** entry, select the **Intel 8255x-based PCI Ethernet Adapter (10/100)** entry. Click the Properties button.
4. Click on the **Driver** button, then click **Update Driver..**button.
5. Update Device Driver Wizard starts, click **NEXT**
6. Select **Display a list of ...** and click **NEXT**. The next window allows the user to specify a specific path. Insert the CD and click **Have Disk**.
7. Browse the 82559 driver in the following path:
X:\CHIPDRV\LAN\100pdisk, highlight **net82557.inf**, click **OK**. The Update Wizard displays the message that it has found the driver. Click OK again to update the driver. Note: Windows 98 may ask you to insert the original Windows 98 CD to install the LAN protocols.
8. Click **NEXT** button, then the Wizard summary window appears.
9. Click **Finish** button, then restart the computer to activate the new driver.

4.4 Driver Installation on Windows NT

Before installing LAN driver on Windows NT, please copy the files of LAN driver in the CD to your hard disk. You may copy the relative NT drivers in the directory below.

X:\CHIPDRV\LAN\100pdisk

where X is the CD-ROM drive.

After booting, Windows NT may detect the hardware of the LAN card and ask to install a LAN driver from its own library of drivers. We recommend you to manually update the LAN driver on ADLINK CD to ensure the compatibility. Please update the driver through the following steps.

1. From the **Control Panel**, double-click the **Network** icon, a **Network Configuration** window will pop up.
2. Click **ADD** button, **Select Network Adapter** window will pop up, there are several adapter models on the list.
3. Click **Have Disk** and type in the complete path of the directory contained LAN driver you saved earlier.
4. A **Select OEM Option** window pop up, click **OK**, then click **Next>**.
5. Select necessary Network Protocols, click **Next>**.
6. Select necessary Network Services, click **Next>**.
7. Click **Next>** until Windows NT Setup dialog box pop up. Type in **X:\V386** in the dialog box, then insert the original Windows NT CD, click **Continue**.
8. Then click **OK** until the setup is completed.
9. Restart the computer.

4.5 Driver Installation on Red Hat Linux

The 82559 source code has been included in Red Hat 6.2, 7.0, 7.1 and 7.2 Linux kernel. So what you need to do is plug your card in and boot Red Hat, then the driver will be automatically installed.

5

Bypass and WDT

The bypass function on PCI-8214 is used to link (or short) two independent Ethernet ports when user's application software halt or when power is off.

5.1 Bypass Operation

5.1.1 Block Diagram

The following diagram shows the operation of bypass on PCI-8214:

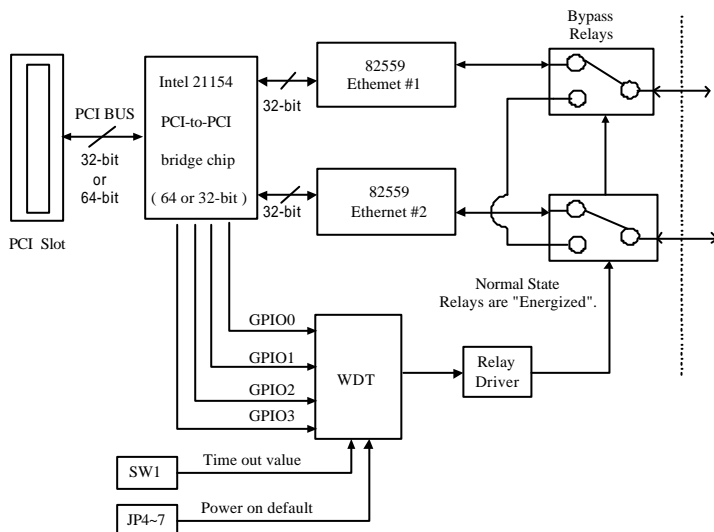

5.1.2 Communication States

There are two communications states for the bypass function: (1) **Normal State**, (2) **Bypass State**. A watch-dog-timer (WDT) is used to control and switch the communication between the two states. A relay array is controlled by the WDT for physically routing of the two Ethernet ports.

The block diagram in the section 5.1.1 shows the **Normal State**, where the two Ethernet ports work independently. The following diagram shows the **Bypass State**, where the two Ethernet ports are bypassed together.

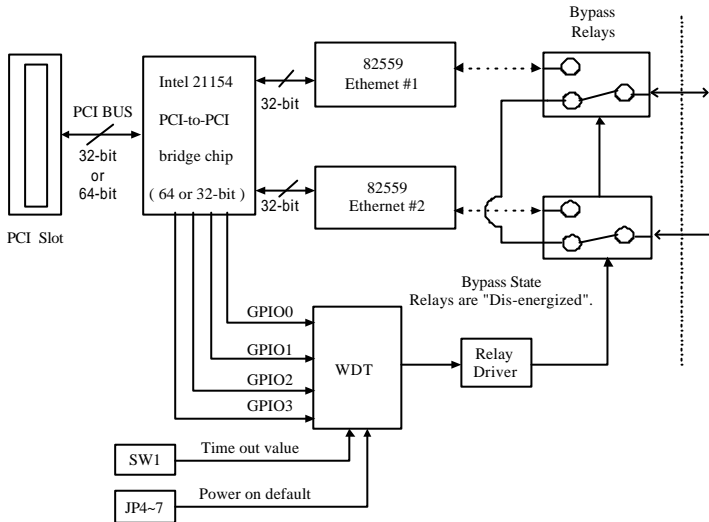

5.1.3 WDT Test Utilities

Before programming this card, users can evaluate the functionality by using the DOS test utilities which in the ADLINK CD. Please refer the section 5.3 for list of the functions. The following section also explains how to use those utilities to change the communication states.

5.1.4 WDT and State Change

This section shows the flow how software and WDT control the state change. The power on status can be choose as either **Bypass State** or **Normal State** by jumper JP4~7.

Default State Setting

The JP4~7 set the **Default State** of communication as following:

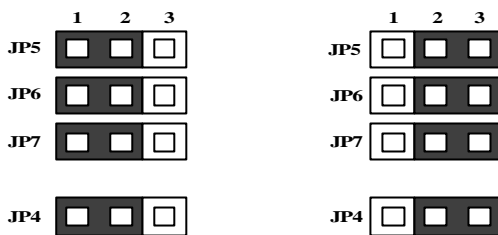

Default Normal State

Default Bypass State

After the system power on or PCI reset, the communication will be in the **Default State**, which can be either **Bypass State** or **Normal State**. The factory default setting is the **Bypass State**.

When power on default setting is Bypass State

Power	WDT	State	Note	DOS Test Utility
Off	Disable	Bypass	Relay physical character	--
On	Disable	Bypass	Default Power ON State	--
On	Disable	Normal	Set LAN to normal mode	NOBYPASS.EXE
On	Enable	Normal	Enable WDT and keep reload WDT	LANWDT.EXE
On	Enable	Bypass	Enable WDT but will timeout if no reload	ENWDT.EXE
On	Disable	Normal	Disable WDT and set to normal mode	DISWDT.EXT
Off	Disable	Bypass	Relay physical character	--

When power on default setting is Normal State

Power	WDT	State	Note	Utility(DOS)
Off	Disable	Bypass	Relay physical character	--
On	Disable	Normal	Default Power on State	--
On	Enable	Normal	Enable WDT and keep reload WDT	LANWDT.EXE
On	Enable	Bypass	Enable WDT but will timeout if no reload	ENWDT.EXE
On	Disable	Normal	Disable WDT and set to normal mode	DISWDT.EXT
Off	Disable	Bypass	Relay physical character	--

When the system is power off, the communication is in the **Bypass State**. After the power on, the communication will be initiated according to the JP4~7 setting. The default WDT is disabled.

The communication state will be change from **Default State** (either **Bypass State** or **Normal State**) into **Normal State** only when user enable the WDT.





Under the **Normal State**, the users' software must reload the WDT to avoid timeout. Once the WDT timeout, **Normal State** will change to **Bypass State** automatically, the WDT is still enabled but keep in timeout status.

To release the timeout, user must disable the WDT by software or turn the power off. The communication will change to **Default State**. When the system power turns off, the communication will change to **Bypass State**.

5.2 WDT control

5.2.1 WDT control



Four signals, which are the GPIO pins of the PCI-to-PCI chip, control the WDT. The function names are listed as the following table:

	Functions	Default	Action command
GPIO0	Enable WDT	H	
GPIO1	Disable WDT	H	
GPIO2	Reload WDT	H	
GPIO3	Force to Normal State	H	

The power up status of those control signals are set as “input” pins therefore the default logic is pulled high. To enable, disable or reload the WDT, the program must set those bits to low then high to generate the rising edge trigger. If the reload of WDT value is larger than time out value, then the communication state will switch to **Bypass State** automatically. The GPIO3 pin is effective only if **JP4-7** setting **Default State** to **Bypass State**.

5.2.2 WDT Time-out Value

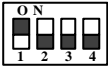
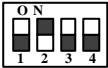
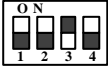
The WDT time-out value is switch selectable by a 4-status switch SW1. The time out value is selectable as 1, 2, 4, or 8 seconds.

SW1		Time out value = 1 second
SW1		Time out value = 2 second
SW1		Time out value = 4 second
SW1		Time out value = 8 second

5.2.3 Programming information of the WDT

Search Intel 21154 PCI-to-PCI bridge

The first step of programming the WDT is to use the 21554 chip information (Vendor ID=1011h, Device ID=0026h, Class Code = 0604h) to search the PCI-8214 card. If the card does exist, then record the bridge' s location (Bus number, Device number and function number) for the further programming.

GPIO Programming on 21154 Chip

The GPIO0~GPIO3 pins of the 21154 chip are used to control the WDT. The following tables list the detailed bit mapping of 65h & 66h register.

GPIO Output Data Register – Offset 65h

Bit	Name	R/W	Description
3:0	GPIO output Write-1-to-clear	R/W1TC	The gpio<3:0> pin output data write-1-to-clear. Writing 1 to any of these bits drives the corresponding bit low on the gpio<3:0> bus if it is programmed as bi-directional. Data is driven on the PCI clock cycle following completion of the configuration write to this register. Bit positions corresponding to gpio pins that are programmed as input only are not driven. Writing 0 to these bits has no effect. When read, reflects the last value written.
7:4	GPIO output Write-1-to-set	R/W1TS	The gpio<3:0> pin output data write-1-to-set. Writing 1 to any of these bits drives the corresponding bit high on the gpio<3:0> bus if it is programmed as bi-directional. Data is driven on the PCI clock cycle following completion of the configuration write to this register. Bit positions corresponding to gpio pins that are programmed as input only are not driven. Writing 0 to these bits has no effect. When read, reflects the last value written.

GPIO Output Enable Control Register – Offset 66h

Bit	Name	R/W	Description
3:0	GPIO output enable Write-1-to-clear	R/W1TC	The gpio<3:0> pin output data write-1-to-enable. Writing 1 to any of these bits drives the corresponding gpio<3:0> pin as input only; that is, the output driver is tristated. Writing 0 to this register has no effect. When read, reflects the last value written.

			Reset value: 0 (all pins are input only)
7:4	GPIO output enable Write-1-to-set	R/W1TS	The gpio<3:0> pin output enable control write-1-to-set. Writing 1 to any of these bits configures the corresponding gpio<3:0> pin as bi-directional, that is, enables the output driver and drives the value set in the output data register (65h). Writing 0 to these bits has no effect. When read, reflects the last value written. Reset value: 0 (all pins are input only)

Generate WDT Commands

Enable WDT:

- (i) Write 01h to reg#65h and 10h to reg#66h (let GPIO0 to be low)
- (ii) Write 10h to reg#65h (Let GPIO0 to be high)

Disable WDT:

- (i) Write 02h to reg#65h and 20h to reg#66h (let GPIO1 to be low)
- (ii) Write 20h to reg#65h (Let GPIO1 to be high)

Reload WDT:

- (i) Write 04h to reg#65h and 40h to reg#66h (let GPIO2 to be low)
- (ii) Write 40h to reg#65h (Let GPIO2 to be high)

Switch to Normal State:

- (i) Write 08h to reg#65h and 80h to reg#66h (let GPIO3 to be low)

Note. The GPIO3 pin is effective only if **JP4-7** setting **Default State** to **Bypass State**.

5.3 DOS Test Utility

The following four test utilities can be used for testing whether if the bypass relays work, before integrating the WDT control into user applications. You can find these 4 utilities in the directory below.

X:WuPROPCI8214WDTutilityDOS

where X is the CD-ROM drive.

ENWDT.EXE:

Enable WDT. The PCI-8214 will switch to ***Bypass State*** in 1,2,4,8 seconds (or time out value) if user does not reload the WDT. When the relays switching, user should hear a click noise, which is the relay's action.

DISWDT.EXE:

Disable and stop WDT. The communication state will keep in ***Default State***.

LANWDT.EXE:

Enable WDT and keep reloading WDT. The WDT will not time-out unless the program stops running or power off. User can turn off the system power to test the bypass function.

NOBYPASS.EXE:

Switch to ***Normal State*** if ***Default state*** is setting to ***Bypass State***.

5.4 WDT DLL for Windows NT & 2000

To use the Watch Dog Timer function of PCI-8214 under Windows NT & 2000, we offer the WDT DLL in the directory below.

X:WuPROPCI8214WDTutilityWT&2K

where X is the CD-ROM drive.

There are two installation procedures to register the WDT DLL to OS. Please follow the below steps to install it.

1. Copy WDT driver to ***WINNT\System32\drivers***. You can find the WDT driver in

X:WuPROPCI8214WDTutilityWT&2KWTDREV386Free.

The file name of WDT driver is ***Pci8213.sys***.

2. Run **P8213reg.reg** in
X:WuPROPCI8214\WDTutilityWT&2KWDRV to register WDT
 DLL to system.
3. Copy **X:WuPROPCI8214\WDTutilityWT&2KLib\LanWDT.dll** to
C:\WINNT\System32
4. Run **X:WuPROPCI8214\WDTutilityWT&2K\Sample**
\SdkLanWDT\LanWDT.exe
5. Select *index card number*, enter **OK**.

5.5 WDT Library for Linux

5.5.1 WDT Installation for Linux

The Linux Module of WDT had been tested under Linux kernel 2.2.12 and ready for 2.4.2. They are put into **X:WuPROPCI8214\WDTutility\Linux** directory.

To use this module for testing WDT function of PCI-8214, some steps of installation are listing as follows:

1. **UNPACK**

Copy **8213_wdt.tgz** to Linux system and decompress the
8213_wdt.tgz : tar xvzf 8213_wdt.tgz

This will extract the '**8213_wdt**' directory with the following subdirectories:

- i. driver/** contains the device module and the installation script
- ii. drvsrc/** contains the source code for 8214 Watch Dog Timer
- iii. lib/** contains the shared library - libLanWDT.so
- iv sample/** contains the sample programs for 8214 Watch Dog
 Timer

2. **INSTALL DEVICE**

Execute the installation script to make nodes for PCI-8214.

<InstallDir>/8213_wdt/driver/wdt_inst.pl
for driver installation

To make driver installation, execute the script as follows:

<InstallDir>/8213_wdt/driver/wdt_inst.pl <Number of PCI-8214
cards>

ex. If you have 3 PCI-8214 cards, please install them with the
 following command : **wdt_inst.pl 3**

The optional parameter '**inst_dir**' is used to indicate the directory of PCI-8214 package. If the PCI-8214 driver can not be found in working directory, the optional parameter '**inst_dir**' is required.

ex. If you have 2 PCI-8214 cards, and install the PCI-8214 package in **/usr/local/8213_wdt**.

install the cards with the command :

wdt_inst.pl 2 /usr/local/8213_wdt

4. **INSTALL LIBRARY**

The library is provided as a shared library. To install the library, type the following command:

Cp <InstallDir>/8213_wdt/lib/libLanWDT.so /usr/lib

In addition, **wdt_inst.pl** also involves the installation for the library.

More detailed information about Linux Module of WDT is listed in readme.dat. (**X:WuPROVPC18214WDTutilityLinux**)

5.5.2 WDT with C Language

```
#include <stdio.h>
#include <stdlib.h>
#include <unistd.h>
#include "LanWDT.h"
#include "conio.h"

int main( void )
{
    int err;
    int timer_interval = 200; // 200 mini-second

    int card_number = 0; /* for the first pci8213 */

    setbuf( stdout, NULL );
    if((err = LanWDT(card_number, timer_interval))<0)
    { //enable Watchdog timer
        printf("Enable WDTimer Error: %d\n", err);
        exit(-1);
    }

    printf(" Enable WDTimer with interval %d sec. \n",
timer_interval );
    printf(" \n\n Press any key to Disable
WDTimer : " );
    getch();

    LanWDT(card_number, 0);//disable Watchdog timer
    putchar('\n');

    return 0;
}
```

Warranty Policy

Thank you for choosing ADLINK. To understand your rights and enjoy all the after-sales services we offer, please read the following carefully.

1. Before using ADLINK' s products, please read the user manual and follow the instructions exactly. When sending in damaged products for repair, please attach an RMA application form.
2. All ADLINK products come with a two-year guarantee, free of repair charge.
 - The warranty period starts from the product' s shipment date from ADLINK' s factory
 - Peripherals and third-party products not manufactured by ADLINK will be covered by the original manufacturers' warranty
 - End users requiring maintenance services should contact their local dealers. Local warranty conditions will depend on the local dealers³. Our repair service does not cover two-year guarantee while damages are caused by the following:
 - a. Damage caused by not following instructions on user menus.
 - b. Damage caused by carelessness on the users' part during product transportation.
 - c. Damage caused by fire, earthquakes, floods, lightening, pollution and incorrect usage of voltage transformers.
 - d. Damage caused by unsuitable storage environments with high temperatures, high humidity or volatile chemicals.
 - e. Damage caused by leakage of battery fluid when changing batteries.
 - f. Damages from improper repair by unauthorized technicians.
 - g. Products with altered and damaged serial numbers are not entitled to our service.
 - h. Other categories not protected under our guarantees⁴. Customers are responsible for the fees regarding transportation of damaged products to our company or to the sales office.

5. To ensure the speed and quality of product repair, please download an RMA application form from our company website www.adlinktech.com. Damaged products with RMA forms attached receive priority.

For further questions, please contact our FAE staff.

ADLINK: service@adlinktech.com

Test & Measurement Product Segment: NuDAQ@adlinktech.com

Automation Product Segment: Automation@adlinktech.com

Computer & Communication Product Segment: NuPRO@adlinktech.com ;
NuIPC@adlinktech.com