

PC-HELPER

100KSPS 16-bit
Analog Input Board
for PCI Express Low Profile

AI-1664LA-LPE

User's Guide

CONTEC CO., LTD.

Check Your Package

Thank you for purchasing the CONTEC product.

The product consists of the items listed below.

Check, with the following list, that your package is complete. If you discover damaged or missing items, contact your retailer.

Product Configuration List

- Board [AI-1664LA-LPE] ...1
- First step guide ...1
- Disk *1 [API-PAC(W32)] ...1
- Standard-sized bracket ...1
- Warranty Certificate ...1
- Serial Number Label ...1

*1 The bundled disk contains the driver software and User's Guide (this guide)

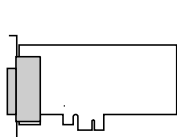

Board

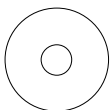

Disk
[API-PAC(W32)]



Standard size
bracket

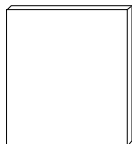

First step guide

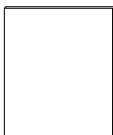

Warranty Certificate



Serial Number Label

Copyright

Copyright 2008 CONTEC CO., LTD. ALL RIGHTS RESERVED

No part of this document may be copied or reproduced in any form by any means without prior written consent of CONTEC CO., LTD.

CONTEC CO., LTD. makes no commitment to update or keep current the information contained in this document. The information in this document is subject to change without notice.

All relevant issues have been considered in the preparation of this document. Should you notice an omission or any questionable item in this document, please feel free to notify CONTEC CO., LTD.

Regardless of the foregoing statement, CONTEC assumes no responsibility for any errors that may appear in this document or for results obtained by the user as a result of using this product.

Trademarks

MS, Microsoft, Windows, Windows NT and MS-DOS are trademarks of Microsoft Corporation. Other brand and product names are trademarks of their respective holder.

Table of Contents

Check Your Package	i
Copyright	ii
Trademarks	ii
Table of Contents	iii

1. BEFORE USING THE PRODUCT	1
------------------------------------	----------

About the Board	1
Features	1
Support Software.....	2
Cable & Connector (Option).....	4
Accessories (Option)	4
Customer Support.....	5
Web Site.....	5
Limited Three-Years Warranty	5
How to Obtain Service.....	5
Liability.....	5
Safety Precautions	6
Safety Information	6
Handling Precautions.....	7
Environment	8
Inspection.....	8
Storage	8
Disposal	8

2. SETUP	9
-----------------	----------

What is Setup?.....	9
Using the Board under Windows Using the Driver Library API-PAC(W32).....	9
Using the Board under Windows Using Software Other than the Driver Library API-PAC(W32)	9
Using the Board under an OS Other than Windows	10
Step 1 Installing the Software	11
About the Driver	11
Starting the Install Program	12
Step 2 Setting the Hardware	14
Replacing the Bracket.....	14
Parts of the Board and Factory Defaults	15
Setting the Board ID.....	15
Plugging the Board	16
Step 3 Installing the Hardware	17
Turning on the PC.....	17

When Using API-AIO(WDM)	17
Step 4 Initializing the Software.....	19
When Using API-DIO(WDM)	19
Step 5 Checking Operations with the Diagnosis Program.....	21
What is the Diagnosis Program?	21
Check Method.....	21
Using the Diagnosis Program	22
Setup Troubleshooting.....	25
Symptoms and Actions.....	25
If your problem cannot be resolved.....	25

3.	EXTERNAL CONNECTION	27
-----------	----------------------------	-----------

How to connect the connectors	27
Connector shape.....	27
Connector Pin Assignment.....	29
Analog Input Signal Connection.....	37
Single-ended Input.....	37
Differential Input	38
Digital I/O signals, Counter signals and Control signals Connection	40

4.	FUNCTIONS	41
-----------	------------------	-----------

Analog Input Function	41
1. Setting the Conversion Conditions	42
2. Starting/Stopping Operation	49
3. Monitoring the Status and Acquiring Data.....	50
4.Reset.....	53
Counter Function.....	54
1. Setting the Operating Conditions	54
2. Starting/Stopping Operation	55
3. Monitoring the Status and Acquiring Data.....	55
4.Reset.....	56
Digital Input Function.....	57
Digital Output Function.....	58

5.	ABOUT SOFTWARE	59
-----------	-----------------------	-----------

Bundled disk Directory Structure	59
About Software for Windows	60
Accessing the Help File.....	60
Using Sample Programs.....	61
Usage of Utility Program	63
Uninstalling the Driver Libraries	66
About Software for Linux	69

Driver Software Install Procedure	69
Accessing the Help File.....	70
Using Sample Programs	70
Uninstalling the driver	70

6.	ABOUT HARDWARE	71
-----------	-----------------------	-----------

For detailed technical information	71
Hardware specification	72
Block Diagram.....	73
Control Signal Timings.....	74
Control Signal Timings for Analog Input.....	74
Control Signal Timings for Analog Output	75
About Calibration	76
Difference from AD16-64(LPCI)LA.....	77

1. Before Using the Product

About the Board

This product is a Low Profile, PCI Express bus-compliant interface board used to provide an analog signal input function on a PC. This product is multi-channels and multifunction type with 16-bit analog input 64 channels (single-ended input 64 channels or differential input 32 channels), digital I/O and counter function. This product carries buffer memory for 1K of data, allowing sampling to be performed in a variety of trigger / clock conditions.

Windows/Linux driver and full-fledged data logger software “C-LOGGER” is bundled with this product.

Possible to be used as a data recording device for MATLAB and LabVIEW, with dedicated libraries.

Features

- High-precision analog input 64 channels, each 4 channels for digital I/O and counter 1 channel
This product has analog input (10 μ sec / channel, 16-bit, 64 channels), analog input control signal (LVTTTL level 3 channels), digital I/O (each 4 channels for LVTTTL level) and counter (32-bit, LVTTTL level 1 channel). Capable of setting the analog input at single-ended input 64 channels and differential input 32 channels.
- The start/end of sampling can be controlled by software, comparison of conversion data, an external trigger, etc.
You can select from software, comparison of conversion data or an external trigger to control the start of sampling. You can select from completion of sampling for a specified number of sessions, comparison of conversion data, an external trigger or software to control forcibly the end of sampling. The sampling cycle can be selected from the internal clock or an external clock.
- Equipped with buffer memory (1K data) that can be used in the FIFO or RING format
The analog input / output block contains buffer memory (1K data) that can be used in the FIFO or RING format. This allows for background analog I/O that does not depend on the operation status of the software or PC.
- Digital filter function included to prevent misdetection due to chattering on external signals
A digital filter is included to prevent misdetection due to chattering on the control signal (external trigger input signal, sampling clock input signal, etc.), digital input signal and counter input signal. (except from external clock input signal and counter gate signal)
- Functions and connectors are compatible with PCI compatible board AD16-64(LPCI)LA.
The functions same with PCI compatible board AD16-64(LPCI)LA are provided. In addition, as there is compatibility in terms of connector shape and pin assignments, it is easy to migrate from the existing system.
- Support for both of low-profile and standard PCI slots (interchangeable with a bundled bracket)
This product has each bracket for both low-profile size slot and standard size slot. If you wish to mount this product in a standard size slot, replace this with the standard size bracket.

- Software-based calibration function

Calibration of analog input can be all performed by software. Apart from the adjustment information prepared before shipment, additional adjustment information can be stored according to the use environment.

- Data logger software, Windows/Linux compatible driver libraries are attached.

Using the bundled data logger software “C-LOGGER” allows you to display recorded signal data in graphs, save files without any special program. In addition, the driver library API-PAC(W32) which makes it possible to create applications of Windows/Linux is provided.

- MATLAB and LabVIEW is supported by a plug-in of dedicated library VI-DAQ.

Using the dedicated library MATLAB and VI-DAQ makes it possible to make a LabVIEW application.

Support Software

You should use CONTEC support software according to your purpose and development environment.

Windows version of analog I/O driver **API-AIO(WDM)**

[Stored on the bundled disk driver library API-PAC(W32)]

The API-AIO(WDM) is the Windows version driver library software that provides products in the form of Win32 API functions (DLL). Various sample programs such as Visual Basic and Visual C++, etc and diagnostic program

*Useful for checking operation is provided.

For more details on the supported OS, applicable language and new information, please visit the CONTEC's Web site.

Linux version of analog I/O driver **API-AIO(LNX)**

[Stored on the bundled disk driver library API-PAC(W32)]

The API-AIO(LNX) is the Linux version driver software which provides device drivers (modules) by shared library and kernel version. Various sample programs of gcc are provided.

For more details on the supported OS, applicable language and new information, please visit the CONTEC's Web site.

Data Logger Software **C-LOGGER**

[Stored on the bundled disk driver library API-PAC(W32)]

C-LOGGER is a data logger software program compatible with our analog I/O products. This program enables the graph display of recorded signal data, zoom observation, file saving, and dynamic transfer to the spreadsheet software "Excel". No troublesome programming is required.

For more details on the supported OS, applicable language and new information, please visit the CONTEC's Web site.

Data Acquisition library for MATLAB **ML-DAQ**

(Available for downloading (free of charge) from the CONTEC web site.)

This is the library software which allows you to use our analog I/O device products on MATLAB by the MathWorks. Each function is offered in accordance with the interface which is integrated in MATLAB's Data Acquisition Toolbox.

For more details on the supported OS, applicable language and new information, please visit the CONTEC's Web site.

Data acquisition VI library for LabVIEW **VI-DAQ**

(Available for downloading (free of charge) from the CONTEC web site.)

This is a VI library to use in National Instruments LabVIEW.

VI-DAQ is created with a function form similar to that of LabVIEW's Data Acquisition VI, allowing you to use various devices without complicated settings.

For more details on the library and download of VI-DAQ, please visit the CONTEC's Web site.

Cable & Connector (Option)

Shielded cables with two-ended connector for 68-pin half-pitch connector

: PCB68PS-0.5P (0.5m)

: PCB68PS-1.5P (1.5m)

Shielded cables with single-ended connector for 68-pin half-pitch connector

: PCA68PS-0.5P (0.5m)

: PCA68PS-1.5P (1.5m)

68/96-pin conversion shielded cable for analog input/output

: ADC-68M/96F (0.5m)

* Two sets of cables are required to use both connector CNA and CNB.

Accessories (Option)

Screw Terminal (M3 x 96P) : DTP-64A *1*3

Screw Terminal (M3 x 68P) : EPD-68A *2*3*4

Screw Terminal (M3 x 96P) : EPD-96A *1*3*4

Screw Terminal (M3.5 x 96P) : EPD-96 *1*3

BNC Terminal Unit (analog input 32ch) : ATP-32F *1*3

BNC Terminal Unit (analog input 8ch) : ATP-8 *1*3*5

*1 ADC-68M/96F optional cable is required separately.

*2 PCB68PS-0.5P or PCB68PS-1.5P optional cable is required separately.

*3 Two sets of cables are required to use both connector CNA and CNB.

*4 “Spring-up” type terminal is used to prevent terminal screws from falling off.

*5 Can be used in CNA channels 0 - 7 or CNB channels 32 - 39.

* For details on the range channels available to each terminal panel, see Figure 3.2 "Connecting example of option".

* Check the CONTEC's Web site for more information on these options.

Customer Support

CONTEC provides the following support services for you to use CONTEC products more efficiently and comfortably.

Web Site

<https://www.contec.com/>

Latest product information

CONTEC provides up-to-date information on products.

CONTEC also provides product manuals and various technical documents in the PDF.

Free download

You can download updated driver software and differential files as well as sample programs available in several languages.

Note! For product information

Contact your retailer if you have any technical question about a CONTEC product or need its price, delivery time, or estimate information.

Limited Three-Years Warranty

CONTEC products are warranted by CONTEC CO., LTD. to be free from defects in material and workmanship for up to three years from the date of purchase by the original purchaser.

Repair will be free of charge only when this device is returned freight prepaid with a copy of the original invoice and a Return Merchandise Authorization to the distributor or the CONTEC group office, from which it was purchased.

This warranty is not applicable for scratches or normal wear, but only for the electronic circuitry and original boards. The warranty is not applicable if the device has been tampered with or damaged through abuse, mistreatment, neglect, or unreasonable use, or if the original invoice is not included, in which case repairs will be considered beyond the warranty policy.

How to Obtain Service

For replacement or repair, return the device freight prepaid, with a copy of the original invoice. Please obtain a Return Merchandise Authorization number (RMA) from the CONTEC group office where you purchased before returning any product.

* No product will be accepted by CONTEC group without the RMA number.

Liability

The obligation of the warrantor is solely to repair or replace the product. In no event will the warrantor be liable for any incidental or consequential damages due to such defect or consequences that arise from inexperienced usage, misuse, or malfunction of this device.

Safety Precautions

Understand the following definitions and precautions to use the product safely.

Safety Information

This document provides safety information using the following symbols to prevent accidents resulting in injury or death and the destruction of equipment and resources. Understand the meanings of these labels to operate the equipment safely.

⚠ DANGER	DANGER indicates an imminently hazardous situation which, if not avoided, will result in death or serious injury.
⚠ WARNING	WARNING indicates a potentially hazardous situation which, if not avoided, could result in death or serious injury.
⚠ CAUTION	CAUTION indicates a potentially hazardous situation which, if not avoided, may result in minor or moderate injury or in property damage.

Handling Precautions

DANGER

Do not use the product where it is exposed to flammable or corrosive gas. Doing so may result in an explosion, fire, electric shock, or failure.

CAUTION

- There are switches and jumpers on the board that need to be set in advance. Be sure to check these before installing the board.
 - Only set the switches and jumpers on the board to the specified settings. Otherwise, the board may malfunction, overheat, or cause a failure.
 - Do not strike or bend the board. Otherwise, the board may malfunction, overheat, cause a failure or breakage.
 - Do not touch the board's metal plated terminals (edge connector) with your hands. Otherwise, the board may malfunction, overheat, or cause a failure. If the terminals are touched by someone's hands, clean the terminals with industrial alcohol.
 - Do not plug or unplug the cables which are connected to the board while the PC or expansion unit is still turned on. Otherwise, the board may malfunction, overheat, or cause a failure. Be sure that the personal computer power is turned off.
 - Do not install or remove the board to or from the slot while the computer's power is turned on. Otherwise, the board may malfunction, overheat, or cause a failure. Be sure that the personal computer or the I/O expansion unit power is turned off.
 - Make sure that your PC or expansion unit can supply ample power to all the boards installed. Insufficiently energized boards could malfunction, overheat, or cause a failure.
 - The specifications of this product are subject to change without notice for enhancement and quality improvement. Even when using the product continuously, be sure to read the manual and understand the contents.
 - Do not modify the product. CONTEC will bear no responsibility for any problems, etc., resulting from modifying this product.
 - Regardless of the foregoing statements, CONTEC is not liable for any damages whatsoever (including damages for loss of business profits) arising out of the use or inability to use this CONTEC product or the information contained herein.
 - Regarding "CE EMC Directive Notice". Please connect the Interface Connector with a shielded cable to meet the mentioned standard above.
-

Environment

Use this product in the following environment. If used in an unauthorized environment, the board may overheat, malfunction, or cause a failure.

Operating temperature

0 - 50°C

Operating humidity

10 - 90%RH (No condensation)

Corrosive gases

None

Floating dust particles

Not to be excessive

Inspection

Inspect the product periodically as follows to use it safely.

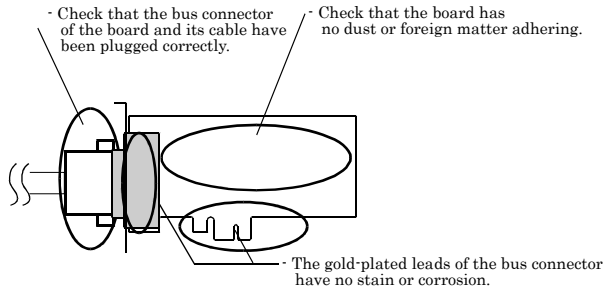

Storage

When storing this product, keep it in its original packing form.

- (1) Put the board in the storage bag.
- (2) Wrap it in the packing material, then put it in the box.
- (3) Store the package at room temperature at a place free from direct sunlight, moisture, shock, vibration, magnetism, and static electricity.

Disposal

When disposing of the product, follow the disposal procedures stipulated under the relevant laws and municipal ordinances.

2. Setup

This chapter explains how to set up the board.

What is Setup?

Setup means a series of steps to take before the product can be used.

Different steps are required for software and hardware.

The setup procedure varies with the OS and applications used.

Using the Board under Windows

Using the Driver Library API-PAC(W32)

This section describes the setup procedure to be performed before you can start developing application programs for the board using the bundled disk “Driver Library API-PAC(W32)”.

Taking the following steps sets up the software and hardware. You can use the diagnosis program later to check whether the software and hardware function normally.

Step 1 Installing the Software

Step 2 Setting the Hardware

Step 3 Installing the Hardware

Step 4 Initializing the Software

Step 5 Checking Operations with the Diagnosis Program

If Setup fails to be performed normally, see the “Setup Troubleshooting” section at the end of this chapter.

Using the Board under Windows

Using Software Other than the Driver Library API-PAC(W32)

For setting up software other than API-PAC(W32), refer to the manual for that software. See also the following parts of this manual as required.

This chapter Step 2 Setting the Hardware

This chapter Step 3 Installing the Hardware

Chapter 3 External Connection

Chapter 6 About Hardware

Using the Board under an OS Other than Windows

For using the board under Linux, see the following parts of this manual.

This chapter Step 2 Setting the Hardware

Chapter 3 External Connection

Chapter 5 About Software

Chapter 6 About Hardware

For using the board under an OS other than Windows and Linux, see the following parts of this manual.

This chapter Step 2 Setting the Hardware

Chapter 3 External Connection

Chapter 6 About Hardware

Step 1 Installing the Software

This explains how to install the driver library.

Before installing the hardware on your PC, install the Driver libraries from the bundled disk.

The following description assumes the operating system as Windows XP. Although some user interfaces are different depending on the OS used, the basic procedure is the same.

About the Driver

There are the two drivers "API-AIO(WDM)" and "API-AIO(98/PC)" among the analog input/output drivers.

API-AIO(WDM) is a new driver to perform analog input and output under Windows.

It was developed aiming at "more easily use and more convenient" "more high performance" corresponding to the product version of API-AIO(98/PC) so far.

Please use the API-AIO(WDM) with this board. API-AIO(98/PC) is not supported.

Starting the Install Program

- (1) Load the bundled disk [API-PAC(W32)] on your PC.
- (2) The API-PAC(W32) Installer window appears automatically.
If the panel does not appear, run (drive letter):\AUTORUN.exe.
- (3) Click on the [Install Development or Execution Environment] button.

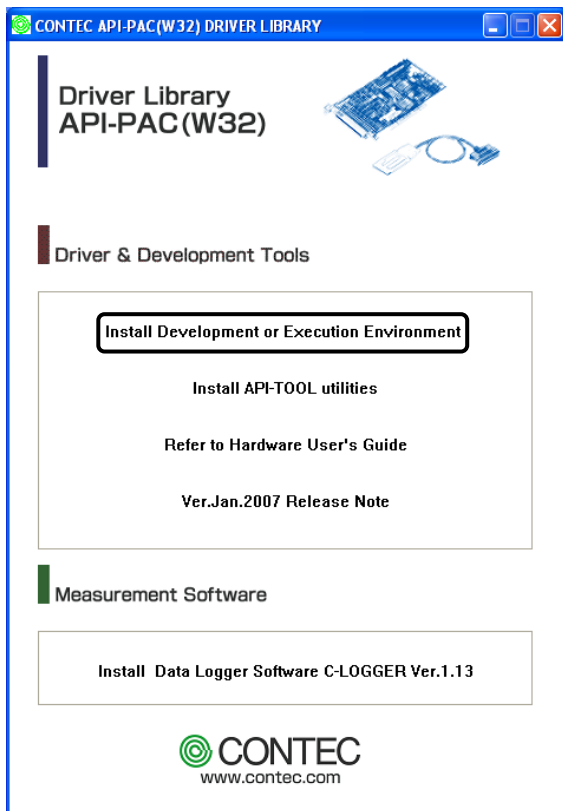

CAUTION

Before installing the software in Windows Vista, XP, Server 2003, 2000, or NT, log in as a user with administrator privileges.

Selecting API-AIO(WDM)

- (1) The following dialog box appears to select “Driver to install” and “Install option”, “Usage of driver library”.
- (2) Select the "High Functionality WDM Analog I/O driver".
- (3) Click on the [Install] button.

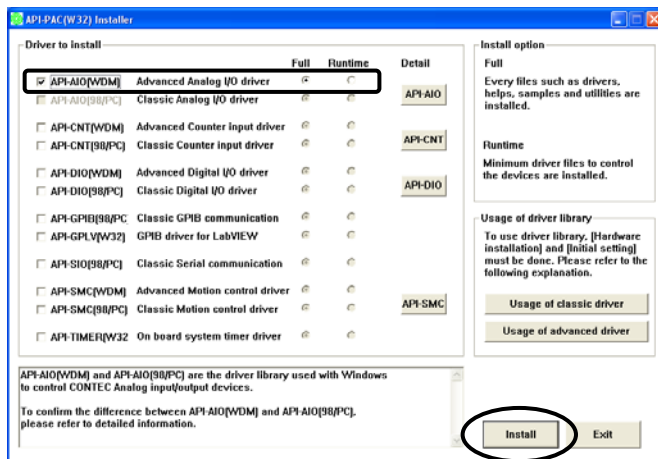

- * Clicking the [Detail] button displays detailed information about API-AIO(WDM) and API-AIO(98/PC).

Run the installation

- (1) Complete the installation by following the instructions on the screen.
- (2) The Readme file appears when the installation is complete.

You have now finished installing the software.

Step 2 Setting the Hardware

This section describes how to set the board and plug it on your PC.

The board has some switches and jumper to be preset.

Check the on-board switches and jumpers before plugging the board into an expansion slot.

The board can be set up even with the factory defaults untouched. You can change board settings later.

Replacing the Bracket

This board is shipped with a Low Profile size bracket mounted. To plug the board into a standard size slot, replace the bracket with the bundled standard-sized bracket. The replacing method is as follows :

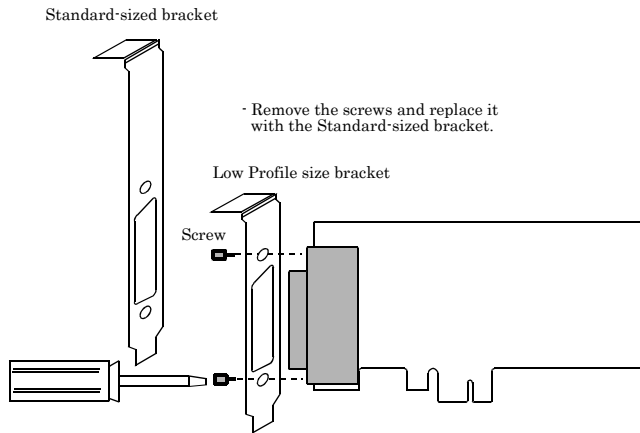

Use a flathead screwdriver or hexagonal spanner to undo and tighten the screws.

Figure 2.1. Replacing the Bracket

Parts of the Board and Factory Defaults

Figure 2.2 shows the names of each part of the board.

The switch settings shown in the figure are the factory default settings.

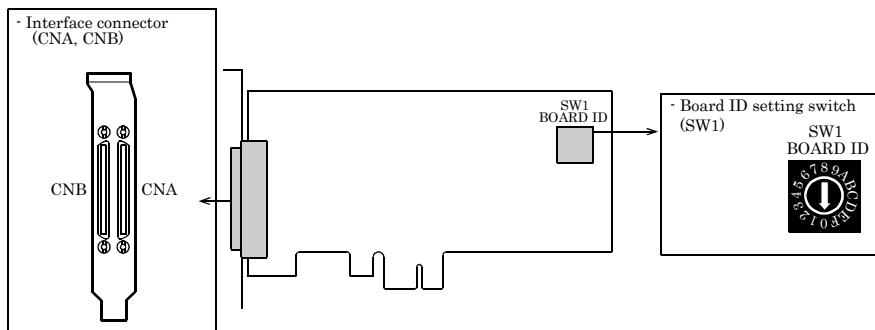

Figure 2.2. Part Names

Setting the Board ID

If you install two or more boards on one personal computer, assign a different ID value to each of the boards to distinguish them.

The board IDs can be set from 0 - Fh to identify up to sixteen boards.

If only one board is used, the original factory setting (Board ID = 0) should be used.

Setting Procedure

To set the board ID, use the rotary switch on the board. Turn the SW1 knob to set the board ID as shown below.

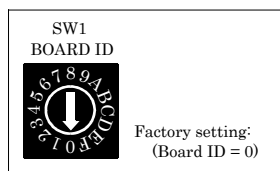
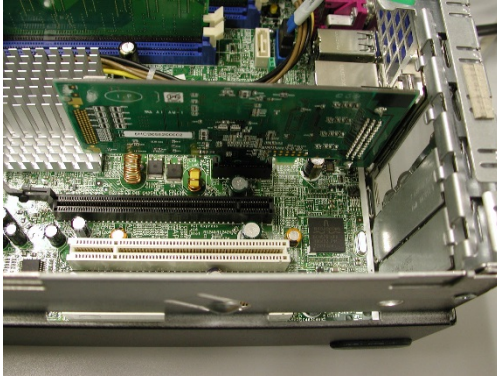

Figure 2.3. Board ID Settings (SW1)

Plugging the Board

- (1) Before plugging the board, shut down the system, unplug the power cord of your PC.
- (2) Remove the cover from the PC so that the board can be mounted.
- (3) Plug the board into an expansion slot.
- (4) Attach the board bracket to the PC with a screw.
- (5) Put the cover back into place.



CAUTION

- Do not touch the board's metal plated terminals (edge connector) with your hands. Otherwise, the board may malfunction, overheat, or cause a failure. If the terminals are touched by someone's hands, clean the terminals with industrial alcohol.
 - Do not install or remove the board to or from the slot while the computer's power is turned on. Otherwise, the board may malfunction, overheat, or cause a failure. Doing so could cause trouble. Be sure that the personal computer or the I/O expansion unit power is turned off.
 - Make sure that your PC or expansion unit can supply ample power to all the boards installed. Insufficiently energized boards could malfunction, overheat, or cause a failure.
-

Step 3 Installing the Hardware

Windows needs to detect the I/O address and interrupt used by the board. This is called hardware installation.

When using more than one board, install the boards one at a time and do not install the next board until setup is complete for the previous board.

Turning on the PC

Turn on the power to your PC.



CAUTION

- The board cannot be properly installed unless the resources (I/O addresses and interrupt level) for the board can be allocated. Before attempting to install the board, first determine what PC resources are free to use.
- The resources used by each board do not depend on the location of the PCI bus slot or the board itself. If you remove two or more boards that have already been installed and then remount one of them on the computer, it is unknown that which one of the sets of resources previously assigned to the two boards is assigned to the remounted board. In this case, you must check the resource settings.

When Using API-AIO(WDM)

- (1) When the "Found New Hardware Wizard" opens, select "Install the software automatically [Recommended]" and then click the "Next" button.

* The wizard may not appear for some OS versions and instead the installation will start automatically. In this case, proceed to the software initial setup step.

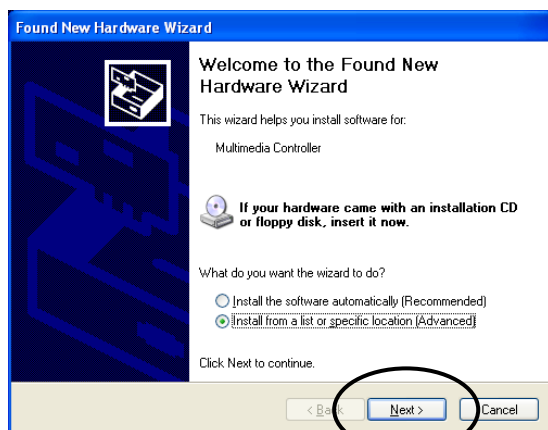

2. Setup

< If using Windows 98 or Windows Me >

If using Windows 98 or Windows Me, specify the folder that contains the setup information (INF) file from the bundled disk.

Source folder

The setup information (INF) file is contained in the following folder on the bundled disk.

\INF\WDM\AIO

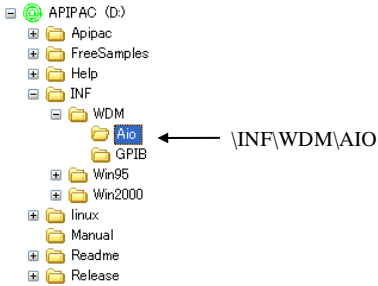

You have now finished installing the hardware.

Step 4 Initializing the Software

The driver library requires initial settings to determine the execution environment. This is called driver library initialization.

When Using API-DIO(WDM)

API-DIO(WDM) is initialized automatically during hardware installation. Therefore, if you want to use it with its initial settings, you can skip the setting procedure described in Step 4. To change the device name, follow the setting procedure shown below.

Setting the device name

- (1) Run Device Manager. From [My Computer] - [Control Panel], select [System] and then select the [Device Manager] tab.
(You can also open Device Manager by right clicking on My Computer and selecting Properties.)

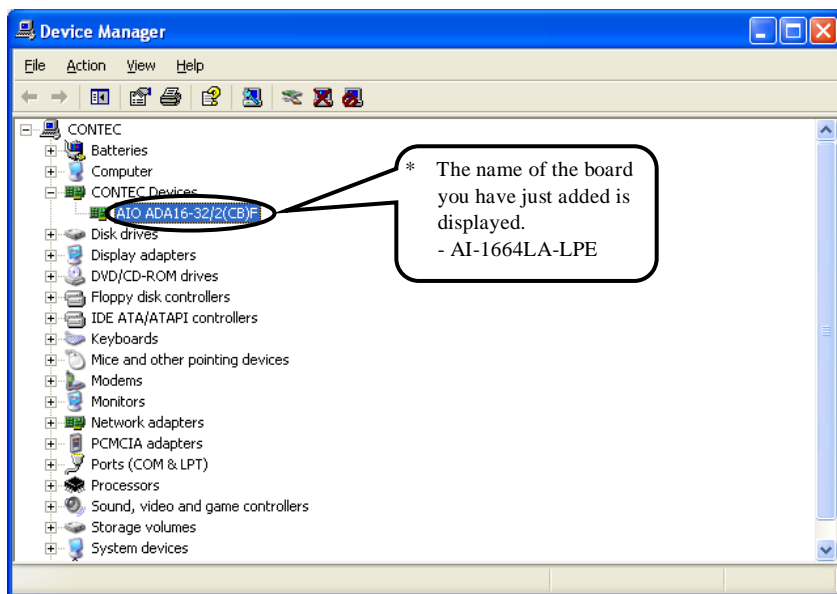

- (2) The installed hardware appears under the CONTEC Devices node. Open the CONTEC Devices node and select the device you want to setup (the device name should appear highlighted). Click [Properties].

(3) The property page for the device opens.

Enter the device name in the common settings tab page and then click [OK].

The device name you set here is used later when programming.

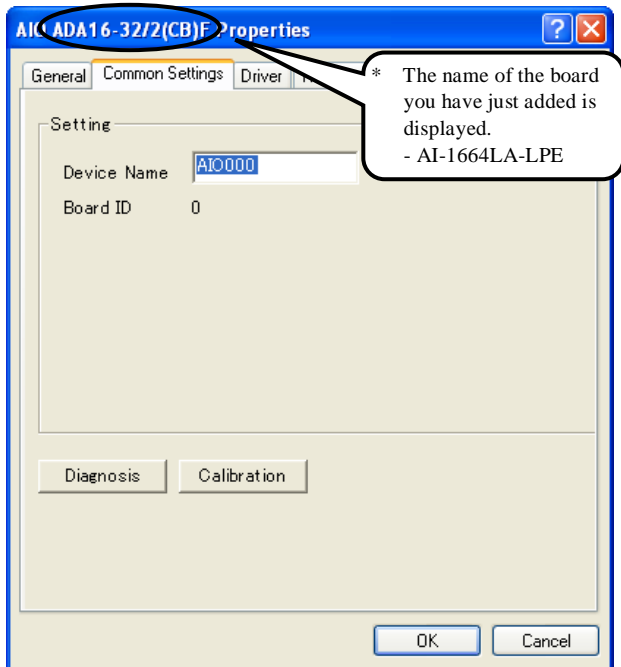

- * The initial device name that appears is a default value. You can use this default name if you wish.
- * Make sure that you do not use the same name for more than one device.

You have now finished installing the initial setting of Software.

Step 5 Checking Operations with the Diagnosis Program

Use the diagnosis program to check that the board and driver software work normally, thereby you can confirm that they have been set up correctly.

What is the Diagnosis Program?

The diagnosis program diagnoses the states of the board and driver software.

It can also be used as a simple checker when an external device is actually connected.

Using the “Diagnosis Report” feature reports the driver settings, the presence or absence of the board, I/O status, and interrupt status.

Check Method

To check the analog input data, connect to an external signal source.

The figure below shows an example of checking by connecting to an external signal.

The example below is for analog input channel 0 on the AI-1664LA-LPE.

Wiring Diagram

< Analog input >

- Single-Ended Input

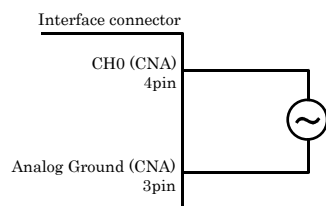

- Differential Input

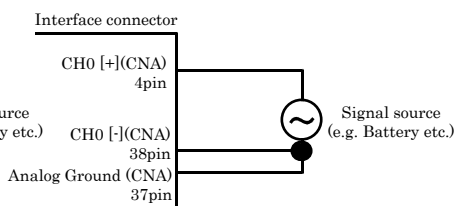

Figure 2.4. Wiring Diagram



CAUTION

- Input data remains indeterminate when no input pin is connected. The input pin for the channel not connected to the signal source must be connected to the analog ground. For details, see “Chapter 3 External Connection”.

Using the Diagnosis Program

Starting the Diagnosis Program

Click the [Diagnosis] button on the device property page to start the diagnosis program.

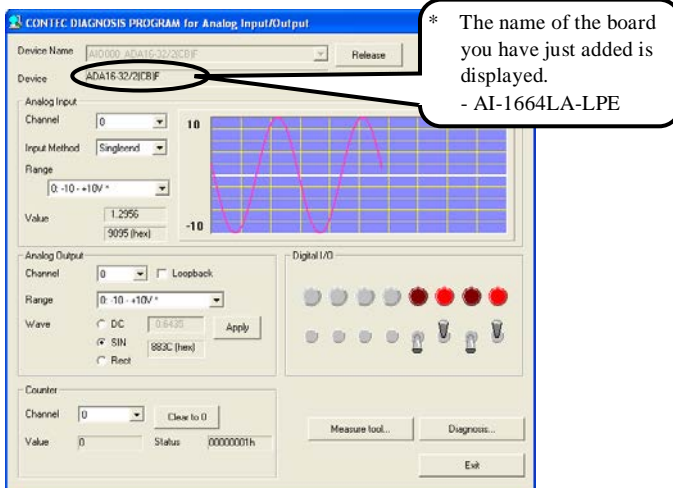
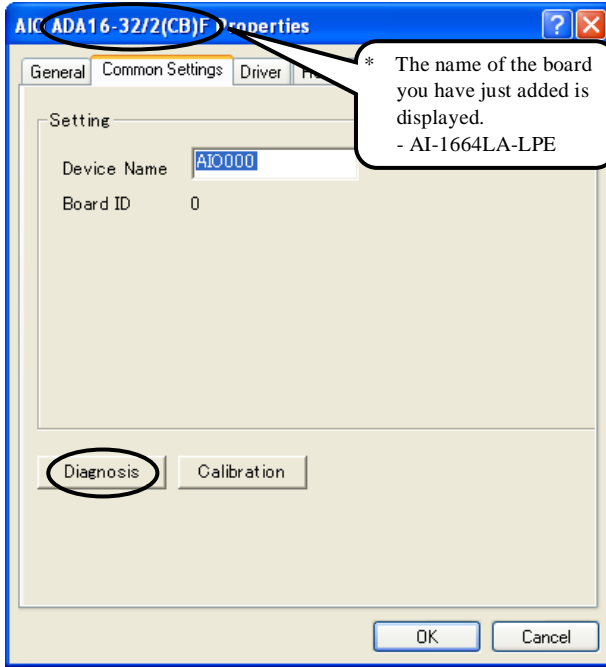

Analog input

Select the input channel, input type, and input range from the lists.

Input data is plotted on a graph.

Digital I/O

The upper row of circular lamps indicates the digital input states. Red indicates the bit is ON and brown indicates OFF.

Clicking the lower row of switches turns the digital output bits ON or OFF.

Counter input

Selecting a counter channel displays the count value and state of that counter channel.

Clicking the zero clear button resets the count to zero.

Diagnosis Report

(1) The diagnosis report saves detailed data, including the device settings and settings for each channel, to a text file and displays the file for you to view.

Clicking [Diagnosis Report] prompts you to specify where to save the report text file.

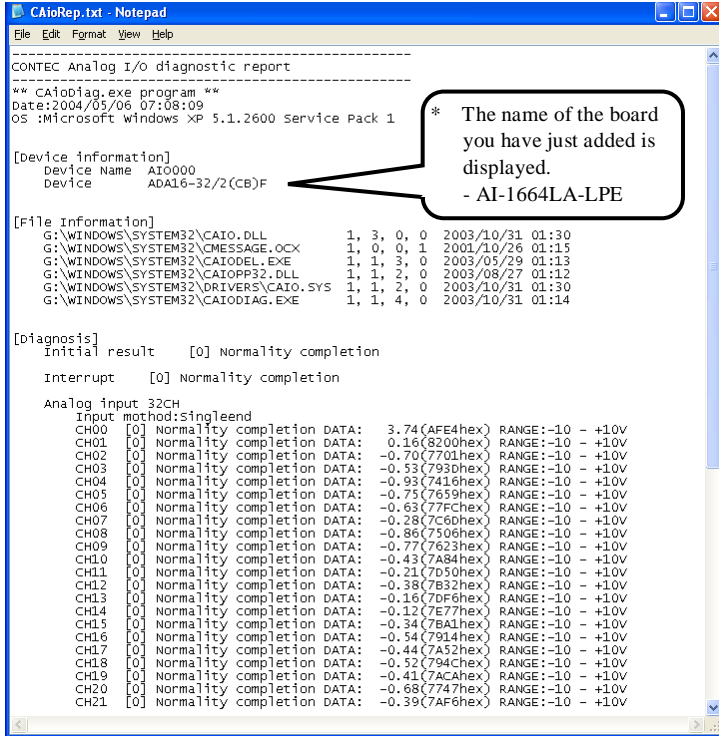

(2) The diagnosis report contains the following data.

- Version of OS
- Device Information
- File Information
- Initialization, interrupts, current input or output state for each channel

Setup Troubleshooting

Symptoms and Actions

Data input does not operate correctly

- Run the diagnosis program to check that the device is registered and whether any initialization errors have occurred.
- Is there a problem with the device settings, wiring, or similar? Check the input range setting. Also, the input data will be undefined if the wiring terminals are not connected. Ensure that the channels you are using are correctly connected. Connect unused channels to analog ground.
- For voltage input, check by connecting a battery or similar if you do not have any other suitable signal source. Also check that a prescribed voltage can input the channel by the short-circuit as an analog ground.

The diagnostic program works correctly but the application program does not.

The diagnostic program uses the API-TOOL functions. If the diagnostic program works correctly, other applications should work correctly also. If you have a problem, recheck your program taking note of the following points.

- Check the return values of the API functions.
- Refer to the source code for the sample programs.

The OS does not boot correctly or does not detect the device correctly.

Refer to the "Troubleshooting" section of API-AIO(WDM) HELP.

If your problem cannot be resolved

Contact your retailer.

3. External Connection

This chapter describes the interface connectors on the board and the external I/O circuits. Check the information available here when connecting an external device.

How to connect the connectors

Connector shape

The optional connector cable (PCB68PS-**P, ADC-68M/96F or PCA68PS-**P) is used to connect the board to external devices. The cable is used together with a terminal block to connect external devices. Two sets of cables are required depending on the number of channels used.

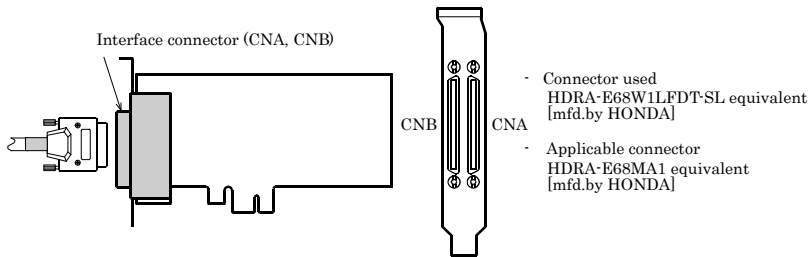

* Please refer to chapter 1 for more information on the supported cable and accessories.

Figure 3.1. Interface Connector Shape

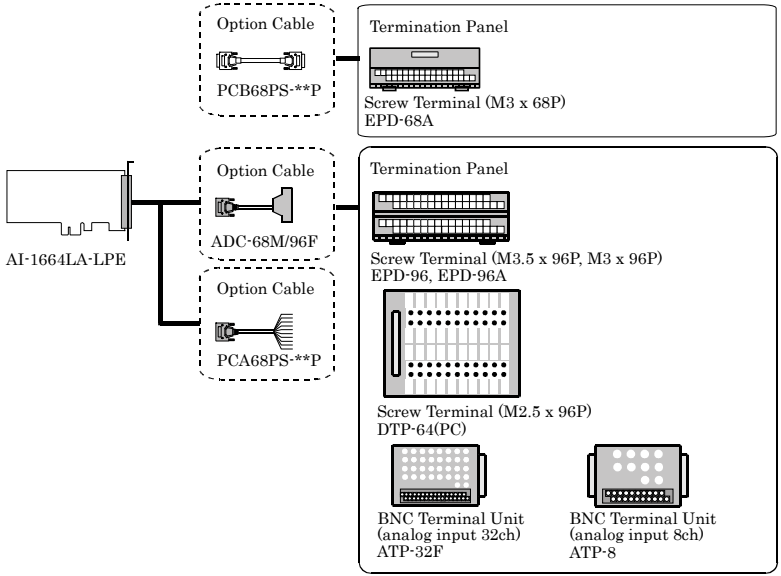

Each terminal block accepts the following ranges of channels.

	Connector at board side connection destination	Analog input		Analog input control signal *1	Digital input Digital output	Counter I/O *2
		Single-ended input	Differential input			
EPD-96A EPD-96 EPD-68A DTP-64	Only CNA is used.	channel 0 - 31	channel 0 - 15	O	O	O
	Only CNB is used.	channel 32 - 63	channel 16 - 31	--	--	--
	CNA/B is used *3	channel 0 - 63	channel 0 - 31	O *4	O *4	O *4
ATP-32F	Only CNA is used.	channel 0 - 31	--	O	O	O
	Only CNB is used.	channel 32 - 63	--	--	--	--
	CNA/B is used *3	channel 0 - 63	--	O *4	O *4	O *4
ATP-8	Only CNA is used.	channel 0 - 7	--	O	O	O
	Only CNB is used.	channel 32 - 39 *5	--	--	--	--
	CNA/B is used *3	channel 0 - 7, 32 - 39 *5	--	O *4	O *4	O *4

*1 : AI External Start Trigger Input, AI External Stop/Trigger Input, AI External Clock Trigger Input
 *2 : Counter Gate Control Input, Counter Up Clock Input, Counter Output
 *3 : Two sets of terminal blocks and optional cables are required each.
 *4 : Make wiring on the CAN side.
 *5 : Two or more only of channel 32 - 39 sampling cannot be done.

Figure 3.2. Connecting example of option

Connector Pin Assignment

Single-Ended Input (CNA, CNB)

N.C	68	34	N.C	1	35	Analog Ground (for AD)
N.C	67	33	N.C	2	36	Analog Ground (for AD)
N.C	66	32	N.C	3	37	Analog Ground (for AD)
N.C	65	31	N.C	4	38	Analog Input 16
N.C	64	30	N.C	5	39	Analog Input 17
N.C	63	29	N.C	6	40	Analog Input 18
N.C	62	28	N.C	7	41	Analog Input 19
Digital Ground	61	27	N.C	8	42	Analog Ground (for AD)
N.C	60	26	N.C	9	43	Analog Input 20
N.C	59	25	N.C	10	44	Analog Input 21
Digital Ground	58	24	N.C	11	45	Analog Input 22
N.C	57	23	N.C	12	46	Analog Input 23
Analog Input 63	56	22	Analog Input 47	13	47	Analog Ground (for AD)
Analog Input 62	55	21	Analog Input 46	14	48	Analog Input 24
Analog Input 61	54	20	Analog Input 45	15	49	Analog Input 25
Analog Input 60	53	19	Analog Input 44	16	50	Analog Input 26
Analog Ground (for AD)	52	18	Analog Ground (for AD)	17	51	Analog Input 27
Analog Input 59	51	17	Analog Input 43	18	52	Analog Ground (for AD)
Analog Input 58	50	16	Analog Input 42	19	53	Analog Input 28
Analog Input 57	49	15	Analog Input 41	20	54	Analog Input 29
Analog Input 56	48	14	Analog Input 40	21	55	Analog Input 30
Analog Ground (for AD)	47	13	Analog Ground (for AD)	22	56	Analog Input 31
Analog Input 55	46	12	Analog Input 39	23	57	Input Control External Sampling Start Trigger Input
Analog Input 54	45	11	Analog Input 38	24	58	Digital Ground
Analog Input 53	44	10	Analog Input 37	25	59	N.C.
Analog Input 52	43	9	Analog Input 36	26	60	N.C.
Analog Ground (for AD)	42	8	Analog Ground (for AD)	27	61	Digital Ground
Analog Input 51	41	7	Analog Input 35	28	62	N.C.
Analog Input 50	40	6	Analog Input 34	29	63	Digital Input 01
Analog Input 49	39	5	Analog Input 33	30	64	Digital Input 03
Analog Input 48	38	4	Analog Input 32	31	65	Digital Output 01
Analog Ground (for AD)	37	3	Analog Ground (for AD)	32	66	Digital Output 03
Analog Ground (for AD)	36	2	N.C	33	67	Counter Count-up Pulse Output
Analog Ground (for AD)	35	1	N.C	34	68	Reserved (Counter Input)

Analog Input00 - Analog Input63	Analog input signal. The numbers correspond to channel numbers.
Analog Ground	Common analog ground for analog input signals.
AI External Start Trigger Input	External trigger input for starting analog input sampling.
AI External Stop Trigger Input	External trigger input for stopping analog input sampling.
AI External Sampling Clock Input	External sampling clock input for analog input.
Digital Input00 - Digital Input03	Digital input signal.
Digital Output00 - Digital Output03	Digital output signal.
Counter Gate Control Input	Gate control input signal for counter.
Counter Up Clock Input	Count-up clock input signal for counter.
Counter Output	Count output signal.
Digital Ground	Common digital ground for digital I/O signals, external trigger inputs,
Reserved	Reserved pin
N.C.	No connection to this pin.

Figure 3.3. Pin Assignment of interface connector (Single-Ended Input)



CAUTION

- Do not connect any of the outputs and power outputs to the analog or digital ground. Neither connect outputs to each other. Doing either can result in a fault.
 - If analog and digital ground are shorted together, noise on the digital signals may affect the analog signals. Accordingly, analog and digital ground should be separated.
 - Leave "Reserved" pins unconnected. Connecting these pins may cause a fault in the board.
-

Single-Ended Input (ADC-68M/96F)

N.C.	B01	A01	N.C.	A48	N.C.	B48	N.C.
N.C.	B02	A02	N.C.	A47	Analog Ground(for AD)	B47	N.C.
N.C.	B03	A03	N.C.	A46	N.C.	B46	N.C.
N.C.	B04	A04	N.C.	A45	Analog Ground(for AD)	B45	N.C.
N.C.	B05	A05	N.C.	A44	Analog Input 00	B44	Analog Input 08
N.C.	B06	A06	N.C.	A43	Analog Input 16	B43	Analog Input 24
N.C.	B07	A07	N.C.	A42	Analog Input 01	B42	Analog Input 09
Digital Ground	B08	A08	Digital Ground	A41	Analog Input 17	B41	Analog Input 25
N.C.	B09	A09	N.C.	A40	N.C.	B40	N.C.
N.C.	B10	A10	N.C.	A39	N.C.	B39	N.C.
N.C.	B11	A11	N.C.	A38	Analog Input 02	B38	Analog Input 10
N.C.	B12	A12	N.C.	A37	Analog Input 18	B37	Analog Input 26
N.C.	B13	A13	N.C.	A36	Analog Input 03	B36	Analog Input 11
N.C.	B14	A14	N.C.	A35	Analog Input 19	B35	Analog Input 27
N.C.	B15	A15	N.C.	A34	Analog Ground (for AD)	B34	Analog Ground (for AD)
N.C.	B16	A16	N.C.	A33	Analog Ground (for AD)	B33	Analog Ground (for AD)
N.C.	B17	A17	N.C.	A32	Analog Input 04	B32	Analog Input 12
N.C.	B18	A18	N.C.	A31	Analog Input 20	B31	Analog Input 28
N.C.	B19	A19	N.C.	A30	Analog Input 05	B30	Analog Input 13
N.C.	B20	A20	N.C.	A29	Analog Input 21	B29	Analog Input 29
Analog Ground (for AD)	B21	A21	Analog Ground (for AD)	A28	N.C.	B28	N.C.
Analog Ground (for AD)	B22	A22	Analog Ground (for AD)	A27	N.C.	B27	N.C.
Analog Input 63	B23	A23	Analog Input 55	A26	Analog Input 06	B26	Analog Input 14
Analog Input 47	B24	A24	Analog Input 39	A25	Analog Input 22	B25	Analog Input 30
Analog Input 62	B25	A25	Analog Input 54	A24	Analog Input 07	B24	Analog Input 15
Analog Input 46	B26	A26	Analog Input 38	A23	Analog Input 23	B23	Analog Input 31
N.C.	B27	A27	N.C.	A22	Analog Ground (for AD)	B22	Analog Ground (for AD)
N.C.	B28	A28	N.C.	A21	Analog Ground (for AD)	B21	Analog Ground (for AD)
Analog Input 61	B29	A29	Analog Input 53	A20	N.C.	B20	N.C.
Analog Input 45	B30	A30	Analog Input 37	A19	N.C.	B19	N.C.
Analog Input 60	B31	A31	Analog Input 52	A18	Digital Input 00	B18	Digital Output 00
Analog Input 44	B32	A32	Analog Input 36	A17	Digital Input 01	B17	Digital Output 01
Analog Ground (for AD)	B33	A33	Analog Ground (for AD)	A16	Digital Input 02	B16	Digital Output 02
Analog Ground (for AD)	B34	A34	Analog Ground (for AD)	A15	Digital Input 03	B15	Digital Output 03
Analog Input 59	B35	A35	Analog Input 51	A14	N.C.	B14	N.C.
Analog Input 43	B36	A36	Analog Input 35	A13	N.C.	B13	N.C.
Analog Input 58	B37	A37	Analog Input 50	A12	N.C.	B12	N.C.
Analog Input 42	B38	A38	Analog Input 34	A11	N.C.	B11	N.C.
N.C.	B39	A39	N.C.	A10	N.C.	B10	N.C.
N.C.	B40	A40	N.C.	A09	N.C.	B09	N.C.
Analog Input 57	B41	A41	Analog Input 49	A08	Digital Ground	B08	Digital Ground
Analog Input 41	B42	A42	Analog Input 33	A07	Input Control External Sampling Clock Input	B07	N.C.
Analog Input 56	B43	A43	Analog Input 48	A06	Input Control External Sampling Stop Trigger Input	B06	N.C.
Analog Input 40	B44	A44	Analog Input 32	A05	Input Control External Sampling Start Trigger Input	B05	N.C.
N.C.	B45	A45	Analog Ground	A04	Counter Clock	B04	N.C.
N.C.	B46	A46	N.C.	A03	Reserved (Counter Input)	B03	N.C.
N.C.	B47	A47	Analog Ground (for AD)	A02	Counter Gate Control Input	B02	N.C.
N.C.	B48	A48	N.C.	A01	Counter Count-up Pulse Output	B01	N.C.

- [] shows the pin No. specified by HONDA TSUSHIN KOGYO CO., LTD.

Analog Input00 - Analog Input63	Analog input signal. The numbers correspond to channel numbers.
Analog Ground	Common analog ground for analog input signals.
AI External Start Trigger Input	External trigger input for starting analog input sampling.
AI External Stop Trigger Input	External trigger input for stopping analog input sampling.
AI External Sampling Clock Input	External sampling clock input for analog input.
Digital Input00 - Digital Input03	Digital input signal.
Digital Output00 - Digital Output03	Digital output signal.
Counter Gate Control Input	Gate control input signal for counter.
Counter Up Clock Input	Count-up clock input signal for counter.
Counter Output	Count output signal.
Digital Ground	Common digital ground for digital I/O signals, external trigger inputs,
Reserved	Reserved pin
N.C.	No connection to this pin.

Figure 3.4. Pin Assignment of interface connector (Single-Ended Input)

⚠ CAUTION

- Do not connect any of the outputs and power outputs to the analog or digital ground. Neither connect outputs to each other. Doing either can result in a fault.
 - If analog and digital ground are shorted together, noise on the digital signals may affect the analog signals. Accordingly, analog and digital ground should be separated.
 - Leave "Reserved" pins unconnected. Connecting these pins may cause a fault in the board.
-

Differential Input (CNA, CNB)

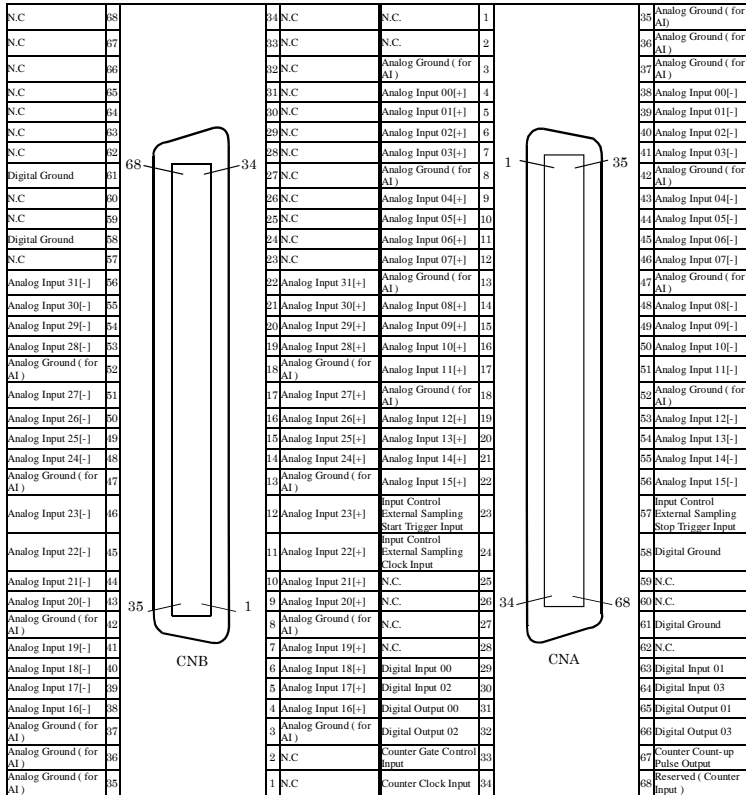

Analog Input00 - Analog Input31	Analog input signal. The numbers correspond to channel numbers.
Analog Ground	Common analog ground for analog input signals.
AI External Start Trigger Input	External trigger input for starting analog input sampling.
AI External Stop Trigger Input	External trigger input for stopping analog input sampling.
AI External Sampling Clock Input	External sampling clock input for analog input.
Digital Input00 - Digital Input03	Digital input signal.
Digital Output00 - Digital Output03	Digital output signal.
Counter Gate Control Input	Gate control input signal for counter.
Counter Up Clock Input	Count-up clock input signal for counter.
Counter Output	Count output signal.
Digital Ground	Common digital ground for digital I/O signals, external trigger inputs.
Reserved	Reserved pin
N.C.	No connection to this pin.

Figure 3.5. Pin Assignment of interface connector (Differential Input)

CAUTION

- Do not connect any of the outputs and power outputs to the analog or digital ground. Neither connect outputs to each other. Doing either can result in a fault.
 - If analog and digital ground are shorted together, noise on the digital signals may affect the analog signals. Accordingly, analog and digital ground should be separated.
 - Leave "Reserved" pins unconnected. Connecting these pins may cause a fault in the board.
-

Differential Input (ADC-68M/96F)

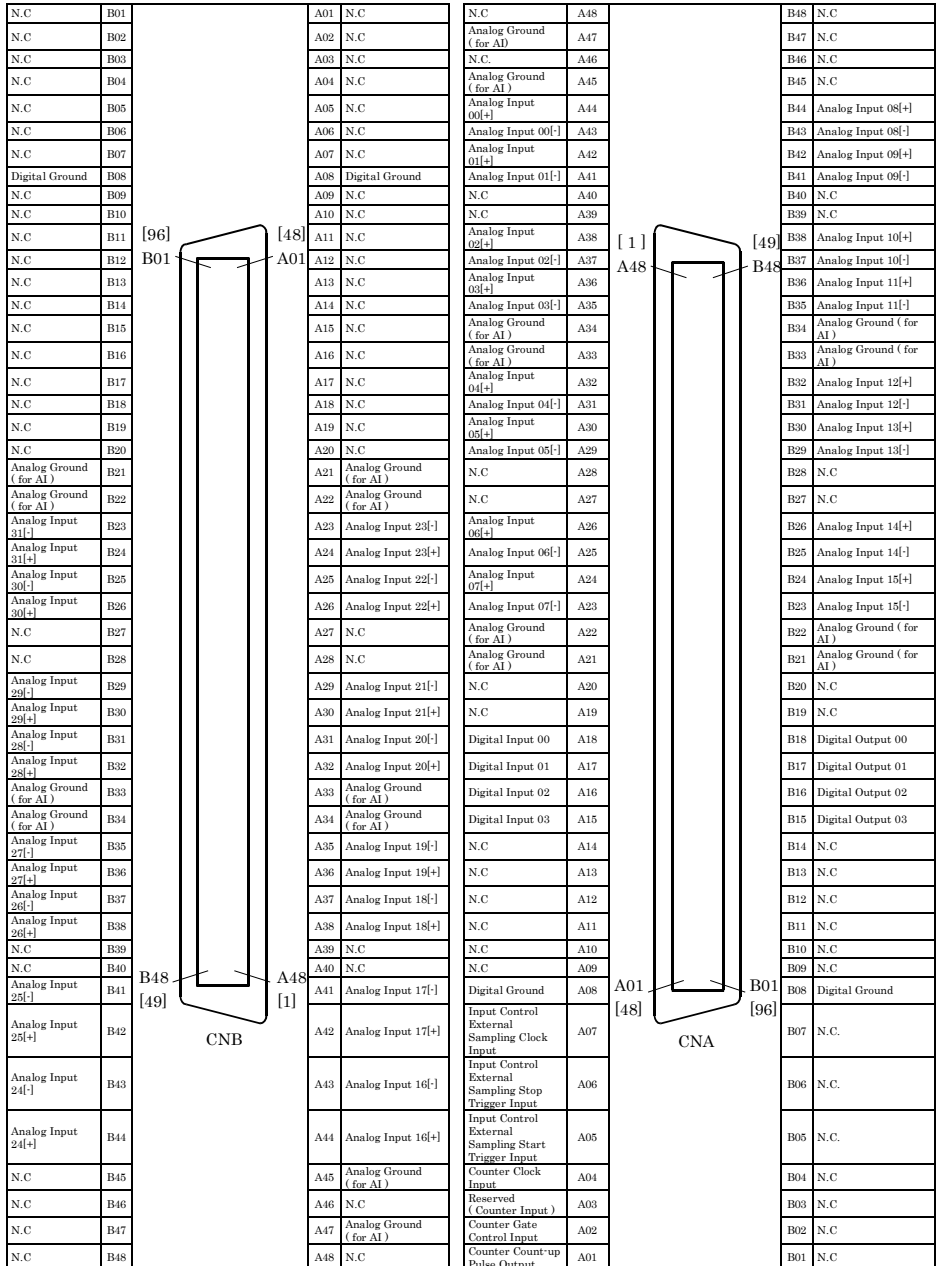

- [] shows the pin No. specified by HONDA TSUSHIN KOGYO CO., LTD.

Analog Input00 - Analog Input31	Analog input signal. The numbers correspond to channel numbers.
Analog Ground	Common analog ground for analog input signals.
AI External Start Trigger Input	External trigger input for starting analog input sampling.
AI External Stop Trigger Input	External trigger input for stopping analog input sampling.
AI External Sampling Clock Input	External sampling clock input for analog input.
Digital Input00 - Digital Input03	Digital input signal.
Digital Output00 - Digital Output03	Digital output signal.
Counter Gate Control Input	Gate control input signal for counter.
Counter Up Clock Input	Count-up clock input signal for counter.
Counter Output	Count output signal.
Digital Ground	Common digital ground for digital I/O signals, external trigger inputs,
Reserved	Reserved pin
N.C.	No connection to this pin.

Figure 3.6. Pin Assignment of interface connector (Differential Input)



CAUTION

- Do not connect any of the outputs and power outputs to the analog or digital ground. Neither connect outputs to each other. Doing either can result in a fault.
 - If analog and digital ground are shorted together, noise on the digital signals may affect the analog signals. Accordingly, analog and digital ground should be separated.
 - Leave "Reserved" pins unconnected. Connecting these pins may cause a fault in the board.
-

Analog Input Signal Connection

The procedure for connecting analog signals depends on whether the analog input signals are single-ended or differential. The sections below describe how to connect the signals using flat cable and shielded cable.

Single-ended Input

The following figure shows an example of flat cable connection.

Connect separate signal and ground wires for each analog input channel on CNA/B.

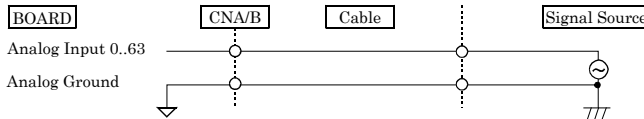

Figure 3.5. Single-ended Input Connection (Flat Cable)

The following figure shows an example of shield cable connection. Use shielded cable if the distance between the signal source and board is long or if you want to provide better protection from noise. For each analog input channel on CNA/B, connect the core wire to the signal line and connect the shielding to ground.

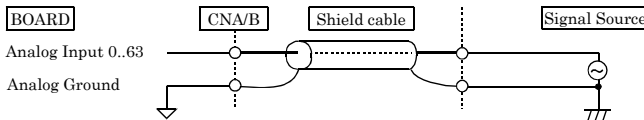

Figure 3.6. Single-ended Input Connection (Shield Cable)

⚠ CAUTION

- If the signal source contains over 1MHz signals, the signal may effect the cross-talk noise between channels.
- If the board and the signal source receive noise or the distance between the board and the signal source is too long, data may not be input properly.
- An input analog signal should not exceed the maximum input voltage (relate to the board analog ground). If it exceeds the maximum voltage, the board may be damaged.
- Connect all the unused analog input channels to analog ground.
- The signal connected to an input pin may fluctuate after switching of the multiplexer. If this occurs, shorten the cable between the signal source and the analog input pin or insert a high-speed amplifier as a buffer between the two to reduce the fluctuation.
- In the channel switching, the multiplexer does the electrical charge and discharge on the internal capacitor according to the signal voltage. Therefore, the voltage from the previous switching state may go into the next channel. It might cause the error of the signal source action. If this occurs, insert a high-speed amplifier as a buffer between the signal source and the analog input pin to reduce the fluctuation.

- An input pin may fail to obtain input data normally when the signal source connected to the pin has high impedance. If this is the case, change the signal source to one with lower output impedance or insert a high-speed amplifier buffer between the signal source and the analog input pin to reduce the effect.

Differential Input

The following figure shows an example of flat cable connection.

For each analog input channel on CNA/B, connect the "+" input to the signal and connect the "-" input to the signal source ground. Also connect the analog ground on the board to the signal source ground.

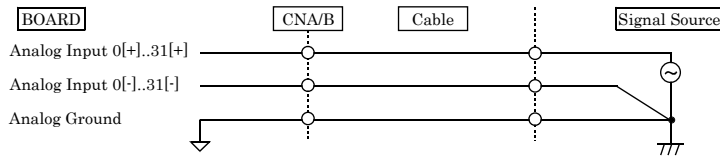

Figure 3.7. Differential Input Connection (Flat Cable)

The following figure shows an example of shielded cable connection. Use shielded cable if the distance between the signal source and board is long or if you want to provide better protection from noise. For each analog input channel on CNA/B, connect the "+" input to the signal and connect the "-" input to the signal source ground. Also connect the analog ground on the board and the signal source ground to the shielding.

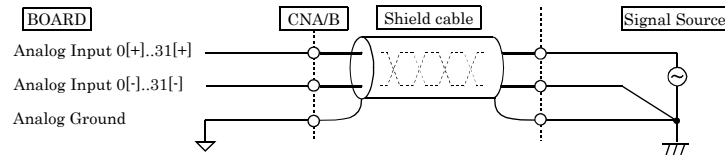

Figure 3.8. Differential Input Connection (Shield Cable)

⚠ CAUTION

- If the signal source contains over 1MHz signals, the signal may effect the cross-talk noise between channels.
- When the analog ground is not connected, the conversion data is not determined.
- If the board and the signal source receive noise or the distance between the board and the signal source is too long, data may not be input properly.
- An input analog signal should not exceed the maximum input voltage (relate to the board analog ground). If it exceeds the maximum voltage, the board may be damaged.
- Connect all the unused analog input channels to analog ground.
- The signal connected to an input pin may fluctuate after switching of the multiplexer. If this occurs, shorten the cable between the signal source and the analog input pin or insert a high-speed amplifier as a buffer between the two to reduce the fluctuation.

- In the channel switching, the multiplexer does the electrical charge and discharge on the internal capacitor according to the signal voltage. Therefore, the voltage from the previous switching state may go into the next channel. It might cause the error of the signal source action. If this occurs, insert a high-speed amplifier as a buffer between the signal source and the analog input pin to reduce the fluctuation.
 - An input pin may fail to obtain input data normally when the signal source connected to the pin has high impedance. If this is the case, change the signal source to one with lower output impedance or insert a high-speed amplifier buffer between the signal source and the analog input pin to reduce the effect.
-

Digital I/O signals, Counter signals and Control signals Connection

The following sections show examples of how to connect digital I/O signals, counter I/O signals, and other control I/O signals (external trigger input signals, sampling clock input signals, etc.).

All the digital I/O signals and control signals are LVTTTL level signals.

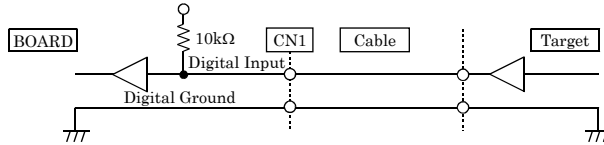

Figure 3.9. Digital Input Connection

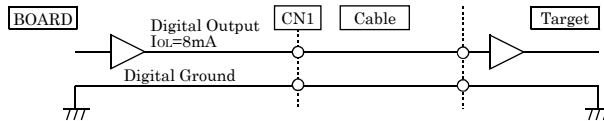

Figure 3.10. Digital Output Connection

Counter input signal control

The counter gate control input (see Connector Pin Assignment in Chapter3) enables or disables the external clock input to the counter. You can use this function to control the external clock input to the counter. The external clock input to the counter is enabled when the input is "High" and disabled when the input is "Low". As the pin has an internal pull-up on the board (or card), the default if not connected is "High". As a result, the external clock for the counter is enabled if this pin is not connected.

⚠ CAUTION

Do not short the output signals to analog ground, digital ground, and/or power line. Doing so may damage the board.

Reference

For the operation timings for control signal input, see "Control Signal Timings" in Chapter 6 "Hardware".

4. Functions

This chapter describes the different functions that can be implemented using the hardware and driver together. Unless stated otherwise, the driver is assumed to be API-AIO(WDM).

Analog Input Function

The board converts analog signals to digital data according to the resolution and stores it in memory. You can set a variety of conditions for analog input, including the input channel, sampling period, and sampling start/stop conditions.

Analog input processes are classified as follows:

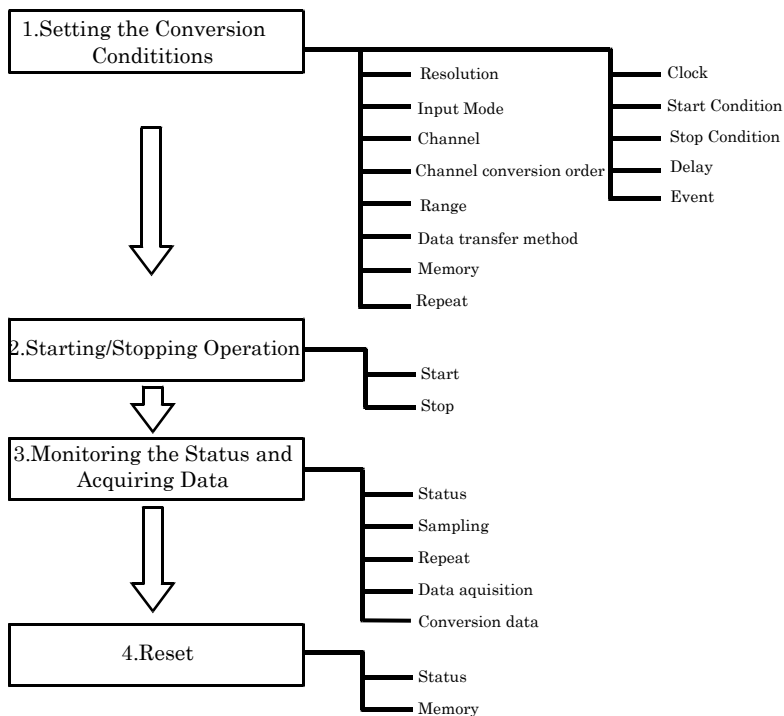

1. Setting the Conversion Conditions

First, set the conditions for executing analog input.

Resolution

"Resolution" signifies the number of bits used by an analog input device to represent analog signals. The higher the resolution, the more finely the voltage range is segmented, allowing the device to convert analog values to digital equivalents more precisely.

A device with a resolution of 12-bit divides the range width into 4096 segments.

When the device covers the range of 0 - 10V, the minimum unit of converted voltages is $10 \div 4096 \approx 2.44\text{mV}$.

If the device has a resolution of 16-bit, it is $10 \div 65536 \approx 0.153\text{mV}$ instead.

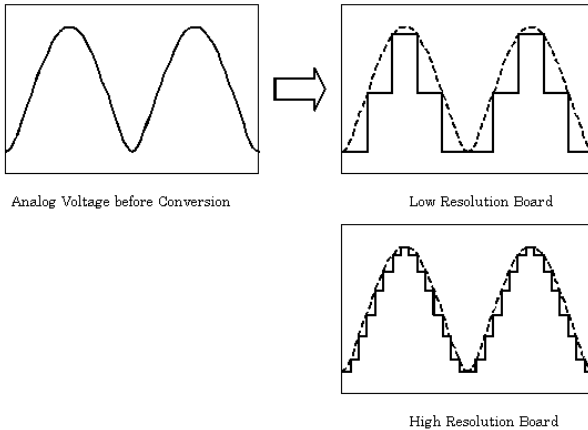

AI-1664LA-LPE : The resolution is 16-bit.

Input Mode

"Input Mode" indicates the method of connecting analog input signals.

The input modes available are single-ended input and differential input.

The single-ended input mode is suitable for the environment in which the potential difference between the signal source and ground and noise components can be ignored. For the environment in which they cannot be ignored, the differential input mode is suitable.

The number of channels available in differential input mode is half that in single-ended input mode.

This board uses on-board jumpers to set the input mode.

Channel

"Channel" represents each channel No. of analog input signal.

For channel numbers, see "How to connect the connectors" to "Connector Pin Assignment" in Chapter 3 "External Connection".

The channel selection specifies the channel number or the number of channels (channel consecutive from channel 0) in which it wants to convert AD.

Channel conversion order

Normally, when performing conversion for more than one channel at each sampling, conversion is performed consecutively starting from channel 0.

Software setup is not required as this board uses a fixed channel conversion priority.

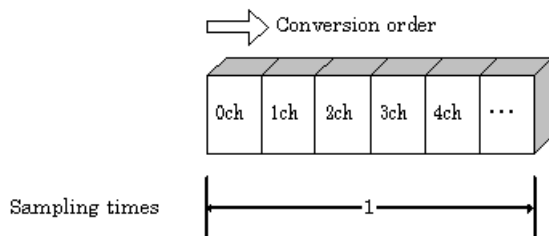

Range

"Range" means the range of voltages at which analog input can be performed

Software setup of the range is not required as this board uses a fixed range of voltages.

AI-1664LA-LPE : $\pm 10\text{V}$

Data transfer method

A device buffer mode is available, which uses the device's or driver's conversion data storage memory.

- **Device buffer mode**

When conversion starts, data is saved in the device buffer (memory on the device itself or in the driver).

The device buffer can operate as FIFO or ring memory.

The application calls an API function at an appropriate timing and fetches the conversion data from the device buffer.

The device buffer mode provides function that allows the number of items of conversion data using the number of sampling times as a unit to obtain the number of items of conversion data directly from the voltage.

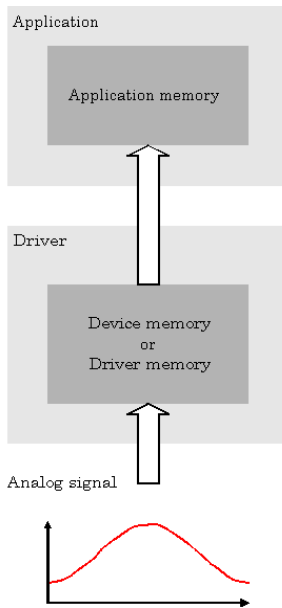

Device buffer mode

Memory format

This board uses device buffer transfer mode; it does not require software setup of the memory format.

Device buffer mode

- FIFO format

In the FIFO (First In First Out) format, input data items are read from memory in the same order in which they were written to the memory. Input data items are fed out of the memory sequentially, where the oldest one is always read from the memory. The status monitor and application notification functions are provided, which check and report the state in which the memory has stored a fixed amount of data or in which the memory has become full.

The FIFO memory is used to obtain all input data from analog input in a short or infinite period of time.

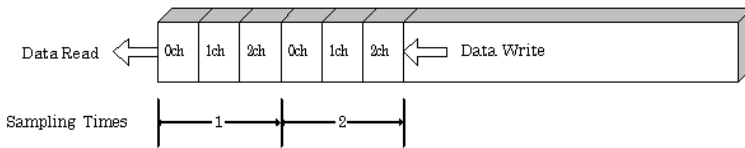

- Ring format

In the ring format, the memory contains storage areas arranged in a ring. Input data items are written to the memory sequentially. When it stores data exceeding the limit, it overwrites the area storing the previous item of input data. The status monitor and application notification functions are provided, which check and report the state in which data has been written to certain areas of memory.

The ring memory is used to obtain data where conversion has stopped due to some event, usually without obtaining data in the normal state.

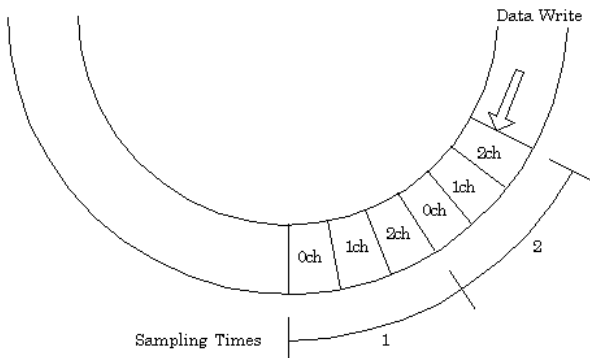

Repeat

”Repeat” indicates the number of repetitions of sampling to be executed, from when the sampling start condition is satisfied until the end of sampling, including delayed sampling.

The number of repetitions is set by means of software, for which conversion is repeated. You can set an infinite number of repetitions, in which case the conversion is terminated by the software abort command.

Input data items are stored to the memory sequentially. The repetition state can be subject to status monitoring and application notification.

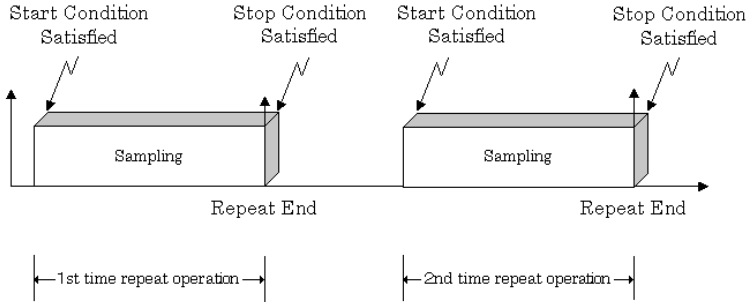

Clock

The sampling clock controls the sampling frequency. You can select both the internal sampling clock and external sampling clock.

- Internal sampling clock
The clock signal from the on-board clock generator is used.
- External sampling clock
The edge of the digital signal input from an external device is used for the sampling clock.

Start Condition

The condition for controlling the start of sampling can be selected from among software, input data comparison and an external trigger. The conditions for controlling the start and stop of sampling are completely independent of each other; they can be set separately.

- Software
The board starts sampling and storing input data to memory immediately after the operation start command is issued.
- Input data comparison
When the operation start command is issued, the board compares the analog signal input through a specified channel to the value of the preset comparison level. If the analog signal satisfies the condition, the board starts storing input data.
Level comparison conditions are set as two conditions: level and direction.

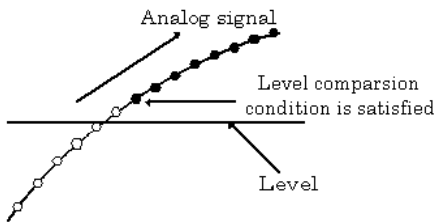

The above sketch shows that the level comparison condition is satisfied in the rising direction. The start condition is satisfied when the analog signal at the specified channel passes the comparison level in the rising direction. Input data items are stored to memory, starting with those at solid dots.

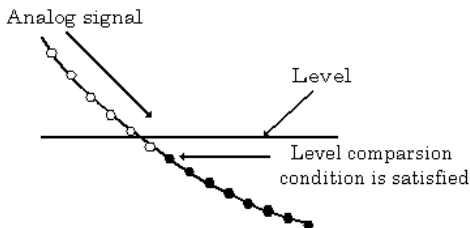

The above sketch shows that the level comparison condition is satisfied in the falling direction. The start condition is satisfied when the analog signal at the specified channel passes the comparison level in the falling direction. Input data items are stored to memory, starting with those at solid dots.

If you set the level comparison directions to both directions, the start condition is satisfied when the analog signal passes the level both in the rising and falling directions.

- External trigger
The board starts waiting for an external control signal as soon as the operation start command is output.
Sampling and data transfer to memory start when the specified edge (rising edge or falling edge) is input from the external control signal.

Stop Condition

The condition for controlling the stop of sampling can be selected from among the last sampling count, input data comparison, an external trigger, and software abort.

The board stops sampling whenever an error occurs irrespective of the stop condition setting.

- Last sampling count
The board stops sampling after storing input data to memory for the specified number of times of sampling.
- Input data comparison
Once the board has started sampling, it compares the analog signal input through a specified channel to the value of the preset comparison level. If the analog signal satisfies the condition, the board stops sampling.
Level comparison conditions are set as two conditions: level and direction.

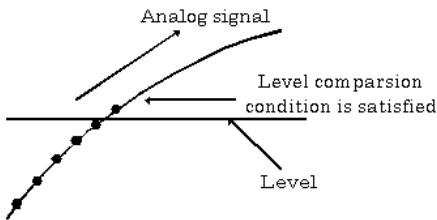

The above sketch shows that the level comparison condition is satisfied in the rising direction. The stop condition is satisfied when the analog signal at the specified channel passes the comparison level in the rising direction. Input data items are stored to memory, ending until those at solid dots.

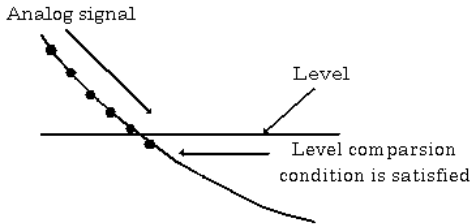

The above sketch shows that the level comparison condition is satisfied in the falling direction. The stop condition is satisfied when the analog signal at the specified channel passes the comparison level in the falling direction. Input data items are stored to memory, ending until those at solid dots.

If you set the level comparison directions to both directions, the start condition is satisfied when the analog signal passes the level both in the rising and falling directions.

- External trigger
The board starts waiting for an external control signal as soon as the operation start command is output.
Sampling and data transfer to memory start when the specified edge (rising edge or falling edge) is input from the external control signal.

Delay

Delayed sampling is performed after the sampling stop condition is satisfied.

When a sampling stop condition other than the software abort command is satisfied, the board performs sampling for the specified number of times of delayed sampling to store input data to memory.

If you set the number of times of delayed sampling to 0, the board stops sampling the moment the sampling stop condition is satisfied.

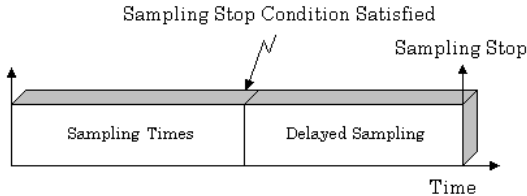

Event

“Event” works as a function for reporting the occurrence of a certain board state to the application.

The following events can be used in combination depending on the specifications and purpose of the application.

- “AD conversion start condition satisfied” event
This event occurs when the AD conversion start condition is satisfied. The event is nullified when the conversion start condition is “software”.
- “Repeat end” event
This even occurs whenever a repetition is completed.
- “End of device operation” event
This event occurs when the entire operation including repetitions is completed.
- “Stored specified sampling times” event
This event occurs when sampling has been performed for the number of times set by software. This event can only be used in device buffer mode.
- Overflow event
This event occurs at an attempt to store input data with the memory full.
- Sampling clock error event
This event occurs when conversion stops as an error occurs due to a sampling clock period that is too short.
- AD conversion error event
This event occurs when conversion stops due to an AD conversion error.

2. Starting/Stopping Operation

Sampling is started by the software command.

Once started, sampling can be stopped by the software command at any timing.

3. Monitoring the Status and Acquiring Data

Software commands are used to monitor the operation status of the device and to acquire input data from memory. Status monitoring and data acquisition can be performed even during sampling.

Status

The current state of the device can be checked by obtaining the device status.

The following types of device status are available:

- Device operating
The “device operating” status remains ON, after the execution of the sampling start command until the board completes conversion, aborts operation due to an error, or stops sampling in response to the command.
- Waiting for start trigger
This status remains ON, after the board starts sampling until the start trigger is input, if the conversion start condition is an external trigger or level comparison. The status is set to OFF when the input trigger is input to start conversion.
The status is set to ON whenever the board enters the conversion start wait status even when repeated operation has been set.
- Specified sampling data stored
This status is set to ON when input data stored in memory has reached the amount corresponding to the preset number of times of sampling.
If the memory format is FIFO, the status is set to OFF when the amount of input data in the memory falls below the value corresponding to the preset number of times of sampling as data is acquired. Once the status is set to ON when the memory format is ring, it remains ON until it is reset.
- Overflow
An overflow error occurs when an attempt is made to store input data to memory while it has been full of input data.
When the memory format is FIFO, the board stops conversion.
When the memory format is ring, the board continues conversion while overwriting existing data with new one.
- Sampling clock error
This error occurs when the sampling clock period is too short.
- AD conversion error
If the “device operating” status remains ON (without terminating conversion) for an extended period of time, the driver regards that state as an operation error and sets this status to ON. This error stops sampling.

Sampling

The number of sampled items of input data stored in memory can be obtained by the software command.

Repeat

The current repeat count can be obtained by the software command.

Data acquisition

The conversion data stored in memory can be retrieved using a software command.

The figure below shows the correspondence between the sampling count and the conversion channel for the conversion data stored in memory.

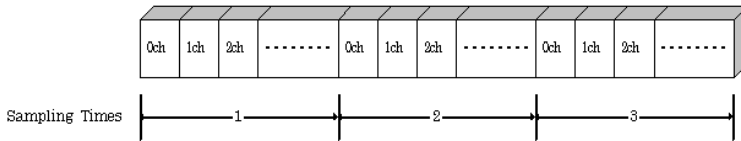

Input data is acquired differently depending on the memory format used.

- Data acquisition in FIFO format

When FIFO memory is used, the oldest data is always read first.

The following sketch shows an image of data acquisition in FIFO format.

When data is acquired from the memory, the free memory space increases by that data size. When data is acquired next, the oldest one of the existing data items is taken from the memory in the same way.

The FIFO memory deletes data once that data is acquired.

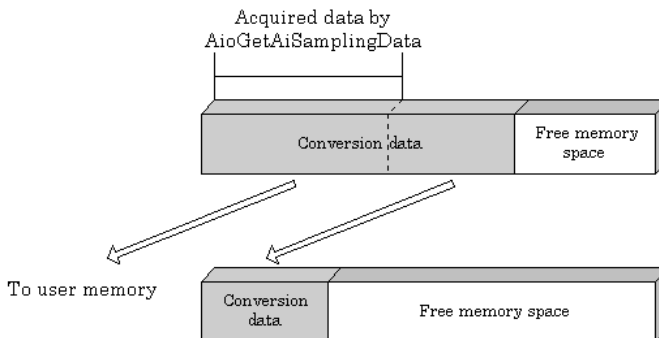

- Data acquisition in ring format

When ring memory is used, data is read always with respect to the current input data write position.

The following sketch shows an image of data acquisition in ring format.

The sampling count obtained is always the number of times of sampling for up to the latest data (shaded portion below).

The larger the number of samples taken, the older the data item acquired first.

As the ring memory retains data even after that data is acquired, you can fetch the same data any number of times.

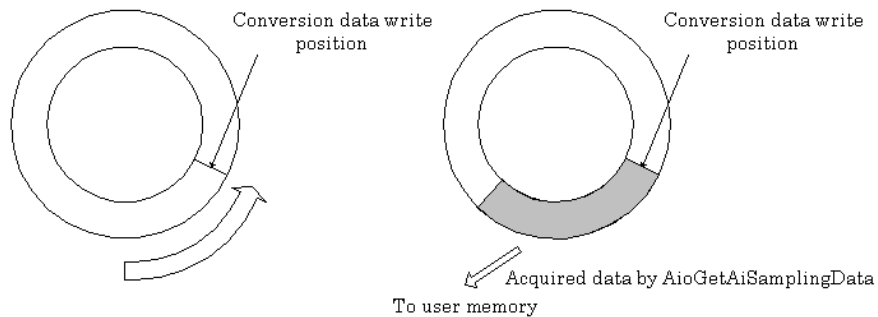

Conversion data

The following equation represents the relationship between input data and voltage.

Voltage = Input data x (Max. range value - Min. range value) / Resolution + Min. range value

The value of resolution for the 16-bit device is 65536.

The table below shows the relationship between input data and voltage in the $\pm 10\text{V}$ range.

Voltage	Conversion data (16-bit)
+9.99970V	65535
:	:
+0.00030V	32769
0V	32768
-0.00030V	32767
:	:
-10.000V	0

Ex.: When input data 49152 is input at a resolution of 16-bit in the $\pm 10\text{V}$ range

$$\begin{aligned} \text{Voltage} &= 49152 \times (10 - (-10)) \div 65536 + (-10) \\ &= 5.0 \end{aligned}$$

4.Reset

Various states can be reset by executing the following reset commands:

Status

This command resets the sampling clock error status and AD conversion error status.

Memory

This can only be used when the transfer mode is set to device buffer mode.

This command resets the following memory related states.

- Resets the conversion data in memory.
- Resets the repeat count to 0.
- Resets the sampling count to 0 when a stop trigger is input.
- Resets the buffer overflow status.
- Resets the status information for the specified data save count.

Counter Function

1. Setting the Operating Conditions

This specifies the conditions for counter operation.

Operating conditions

The basic operation of the counter is to count an external input signal.

The counter includes a function to detect a count match and perform a specified operation when the current count value reaches a preset count value.

Compare count values

The compare count load function automatically loads the next compare count value when a count match occurs.

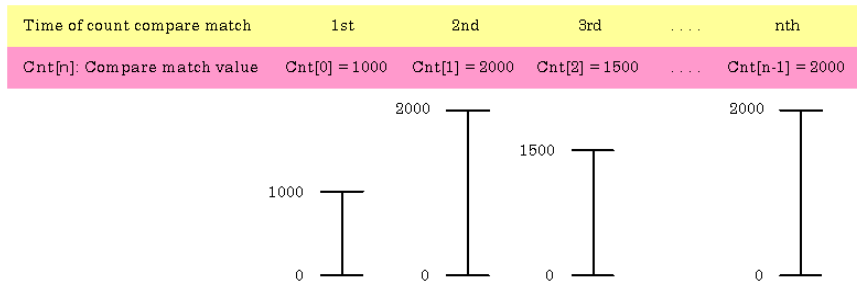

The figure above shows an example of using the compare count load function.

After the counter starts, the first count match occurs when the count reaches 1000.

When the count reaches 1000, the counter value at which the second compare count match is to occur (2000) is set.

This continues with the next value from the array being set each time a count match occurs.

After the final value from the array is loaded, operation can start again from the beginning of the array.

Alternatively, loading can be halted (in which case, the compare count value remains at 2000).

Input signal

The external clock can be selected as the counter input signal.

Digital filter

A digital filter can be used on external input bits.

The filter time can be set to "don't use", 1 μ s by software.

Event

The event function notifies the application when something occurs on the device. The following events can be used as required.

- Compare count match event
This event is triggered when a compare match occurs on the counter.
- Count overrun event
This event is triggered when a counter overrun occurs.
- Counter operation error
This event is triggered when a counter operation error causes the counter to stop.

2. Starting/Stopping Operation

Starting and stopping the counter are performed using software commands. Once the counter has started, it can be stopped at any time by a software command.

3. Monitoring the Status and Acquiring Data

Software commands can be used to monitor the device operating status and read counter data. Status monitoring and data acquisition can both be performed while the counter is running.

Status

The current state of the device can be checked by obtaining the device status. The following types of device status are available:

- Counter operating
The device operating status is ON from the time the operation start command is executed until operation stops due to a stop command or error.
- Compare count match
The compare count match status turns ON when a count match occurs after the counter is started. The status is turned OFF by the status reset command.
- Overrun
The overrun status turns ON if another count match occurs when the compare count match status is already ON. The status is turned OFF by the status reset command. Even if the overrun status turns ON, this does not stop the counter.
- Counter operation error
Execution of driver processing may not be able to keep up if multiple count match events occur within a short time period.
In this case, the counter operation error status turns ON and counter operation stops.

Data acquisition

The current count value can be read using a software command.

4.Reset

Various states can be reset by executing the following reset commands:

Counter reset

Resets the counter. This restores the counter to its state after power on.

Status

Resets the compare count match status and overrun status.

Digital Input Function

Input bit

Individual digital input points are called input bits.

When the number of input points of a device is 4, the bits are determined as bit 0 - bit 3.

Bit 3	Bit 2	Bit 1	Bit 0
-------	-------	-------	-------

Input in Bits

The state 1 (ON) or 0 (OFF) of each input bit can be obtained by specifying the bit.

Input in Bytes

Individual input bits can be input in byte units.

When the number of input points of the device is 4, the individual input bits are arranged as shown below and the byte data to be input is a value between 0 and 15 depending on the states of the bits.

EX. Input of bit 3 (OFF), bit 2 (ON), bit 1 (OFF), bit 0 (ON)

Byte data = 05(5H)

Bit 3	Bit 2	Bit 1	Bit 0
0(OFF)	1(ON)	0(OFF)	1(ON)

Digital filter

A digital filter can be used on the input bits.

The filter time can be set to "don't use", 1 μ s by software.

Digital Output Function

Output bit

Individual digital output points are called output bits.

When the number of output points of a device is 4, the bits are determined as bit 0 - bit 3.

Bit 3	Bit 2	Bit 1	Bit 0
-------	-------	-------	-------

Output in Bits

The state of each output bit can be changed to ON or OFF by specifying the bit and setting it to 1 or 0.

Output in Bytes

Individual output bits can be output in byte units.

When the number of output points of the device is 4, the individual output bits are arranged as shown below and byte data to be output is a value between 0 and 15.

Ex. Output of bit 3 (ON), bit 2(OFF), bit 1 (ON), bit 0 (OFF)

Byte data = 10(AH)

Bit 3	Bit 2	Bit 1	Bit 0
1(ON)	0(OFF)	1(ON)	0(OFF)

5. About Software

Bundled disk Directory Structure

```

\
|— Autorun.exe           Installer Main Window
|  |— Readmej.html       Version information on each driver (Japanese)
|  |— Readmeu.html       Version information on each driver (English)
|  .
|  |— APIPAC             Each installer
|  |  |— AIO
|  |  |  |— DISK1
|  |  |  |— DISK2
|  |  |  |— .....
|  |  |  |— DISKN
|  |  |— AioWdm
|  |  |— CNT
|  |  |— DIO
|  |  |— .....
|  .
|  |— HELP              HELP file
|  |  |— Aio
|  |  |— Cnt
|  |  |— .....
|  .
|  |— INF               Each INF file for OS
|  |  |— WDM
|  |  |— Win2000
|  |  |— Win95
|  .
|  |— linux            Linux driver file
|  |  |— cnt
|  |  |— dio
|  |  |— .....
|  .
|  |— Readme           Readme file for each driver
|  .
|  |— Release          Driver file on each API-TOOL
|  |  |— API_NT        (For creation of a user-specific install program)
|  |  |— API_W95
|  .
|  |— UsersGuide       Hardware User's Guide(PDF files)

```

About Software for Windows

The bundled disk “Driver library API-PAC(W32)” contains the functions that provide the following features:

- Analog input or output through arbitrary channels
- Analog input at arbitrary intervals using the internal or external sampling clock
- Simultaneous monitoring of the termination of analog input sampling, buffer memory usage, and interrupt events such as occurrences of errors
- Driver option check using a demo driver even without the board installed

For details, refer to the help file. The help file provides various items of information such as “Function Reference”, “Sample Programs”, “Tutorial”, “FAQs” and “Troubleshooting”. Use them for program development and troubleshooting.

Accessing the Help File

- (1) Click on the [Start] button on the Windows taskbar.
- (2) From the Start Menu, select “Programs” – “CONTEC API-PAC(W32)” – “AIOWDM” – “API-AIO(WDM) HELP” to display help information.

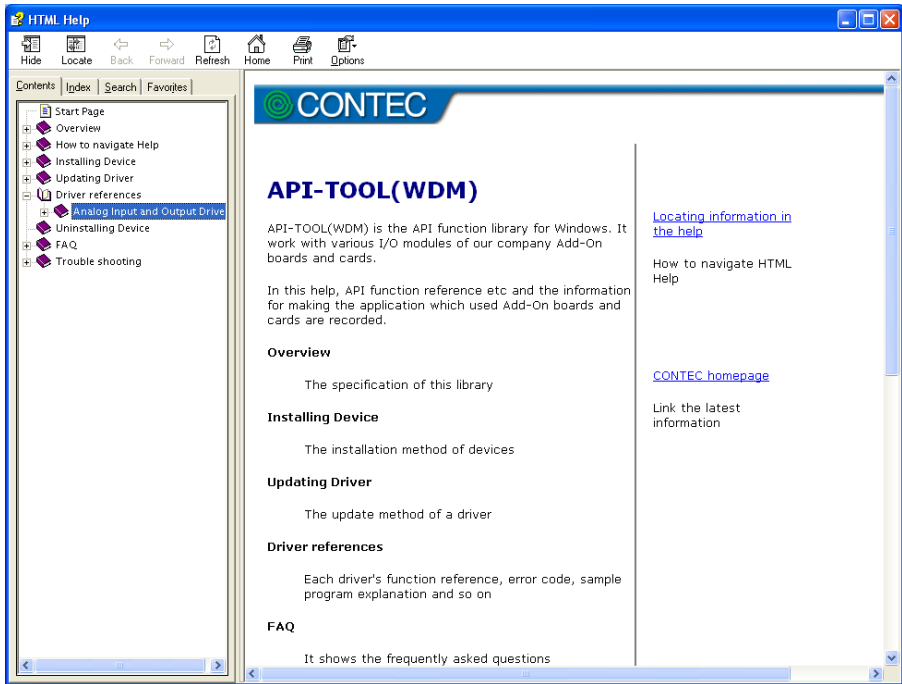

Using Sample Programs

Sample programs are provided for each of the basic operations. You can use these to check the operation of the board and as a reference when writing your own programs.

To use the sample programs, specify the device name in the property page for the program.

The sample programs are stored in \Program Files\CONTEC\API-PAC(W32)\AIOWDM\Samples.

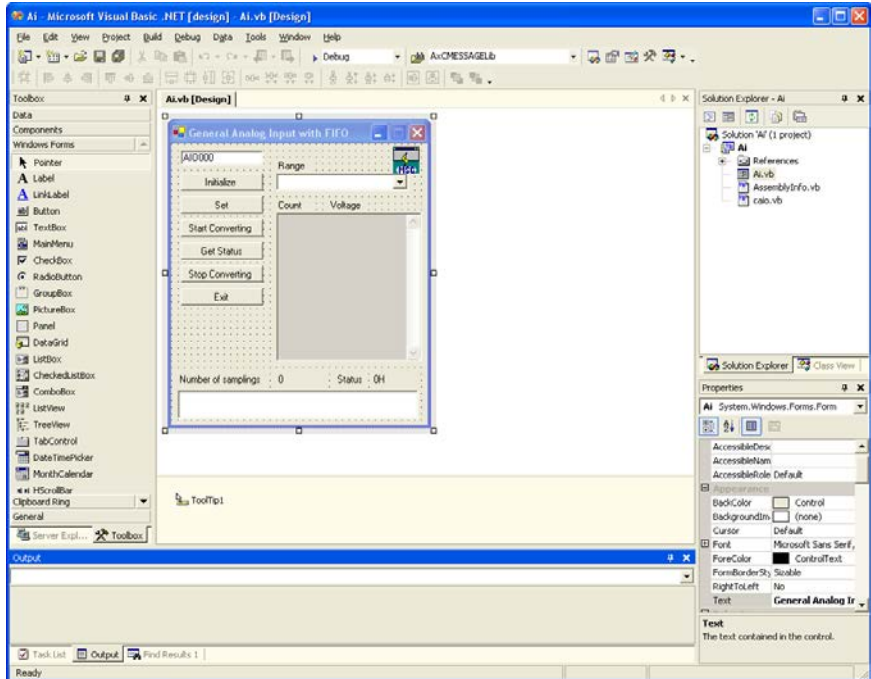

Running a Sample Program

- (1) Click on the [Start] button on the Windows taskbar.
- (2) From the Start Menu, select “Programs” – “CONTEC API-PAC(W32)” – “AIOWDM” – “SAMPLE...”.
- (3) A sample program is invoked.

Sample Programs - Examples

Analog input

Simple sample program

- SingleAi Perform single analog input from specified channel
- MultiAi Perform single analog input from multiple channels

Device buffer

- Ai Perform standard analog input using a FIFO buffer
- AiPoll Perform standard analog input by polling
- AiEx Perform analog input for multiple channels using a FIFO buffer
- AiExt Perform analog input using an external clock
- AiTrg Perform analog input using an external trigger to start and stop operation
- AiLevel1 Use a level trigger to start analog input
- AiLevel2 Use a level trigger to stop analog input
- Ai2 Perform standard analog input using more than one device
- AiCall Perform analog input using a callback routine
- AiSync1 Perform multi-channel analog input using two devices

User buffer

- AiUser1 Perform analog input for a specified duration using a user buffer
- AiUser2 Perform analog input indefinitely using a user buffer

Digital I/O

- DioBit Perform digital I/O using bit values
- DioByte Perform digital I/O using port values

Others

- Convert Data conversion
- Multi1 Synchronized analog I/O

Usage of Utility Program

Program for Measurement of Function Execution Speed

The execution time of some main functions can be measured in a function execution speed measurement program. To use a function execution speed measurement program, click the [execution time measurement] button in the diagnostic program.

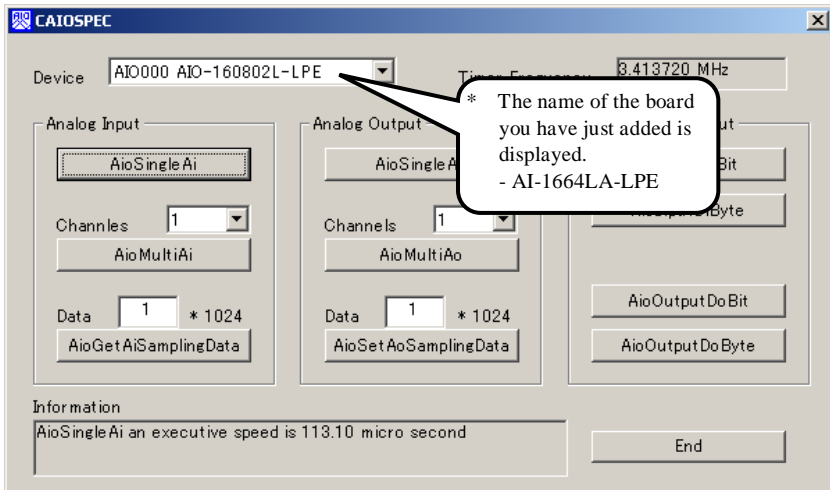

Procedure

- (1) Chose the measure device from device list.
- (2) Click the button written with the function name to measure the execution speed of the function.
Please choose from a list the number of channels used for conversion in function AioMultiAi.
- (3) End the application with an [end] button.

Analog Input Measurement Tool

It is an analog input measurement utility to carry out infinity sample in the FIFO memory. Once the conversion data of memory accumulates to a certain quantity, the event occurs and data of the memory is acquired. Data in the FIFO memory can be confirmed visually.

The number of channels used, the internal/external clock, the conversion speed, and the sampling frequency at which an event generates can be set. Since the notification of a sampling clock error event is sent, please make use of it for the conversion spec measurement under various conversion conditions.

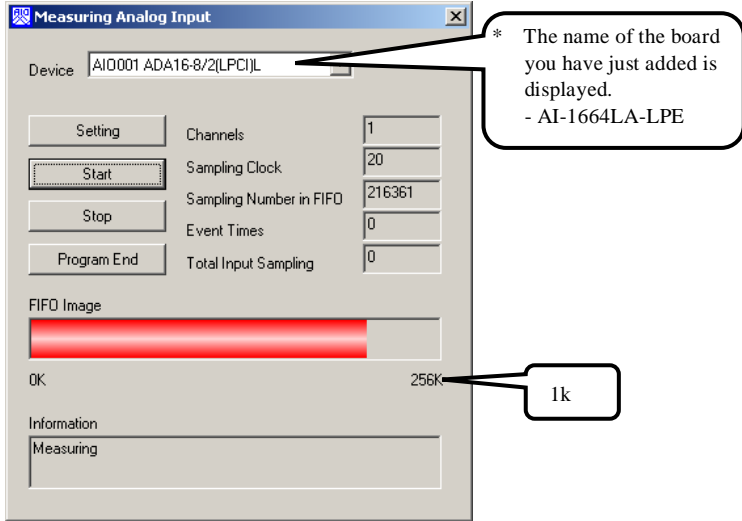

Procedure

- (1) Chose the device name of the device to be used from the upper left combo box, and click the setting button.
- (2) The conversion conditions are set on the screen of the analog input setting.

Once an input is done at the sampling frequency specified as data taking-in sampling, an event occurs and data will be acquired. Click the OK button to finish setting the conditions, and returns to former screen.

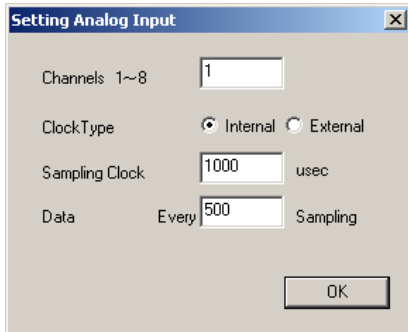

- (3) Start the measurement with measurement start button. The various states during the conversion are displayed.

The number of the samplings in FIFO is :

It is conversion data taken in the memory. This can be visually checked in a "memory image".

Event generation sampling frequency :

When the number of input sampling in FIFO reaches this frequency, the event generates.

Total input sampling frequency :

It is the total number of samplings for application in the memory.

Measurement may stop by the following errors.

Sampling clock error :

It means that the conversion speed is too fast and the driver processing is not in time when converting at the internal clock.

The cycle of the clock is too fast when converting it at the external clock. Moreover, the cause by noise etc. is also concerned.

Buffer overflow :

The memory overflows since the conversion speed is too fast compared with the one at which data is inputted.

- (4) Click the "stop" button, and measurement stops.

Uninstalling the Driver Libraries

The method used to uninstall API-PAC(W32) differs depending on which OS you are using. Follow the procedure given below.

Uninstall procedure for Windows Vista

< Uninstalling the device driver >

1. Run Device Manager. From [My Computer] - [Control Panel], select [System] and then select the [Device Manager] tab.
(You can also open Device Manager by right clicking on My Computer and selecting Properties.)
2. All of the hardware that uses the API-TOOL(WDM) driver is registered under the CONTEC Devices tree.
Open the device tree, select the hardware to uninstall, and then right-click the hardware.
From the popup menu, select [Uninstall].

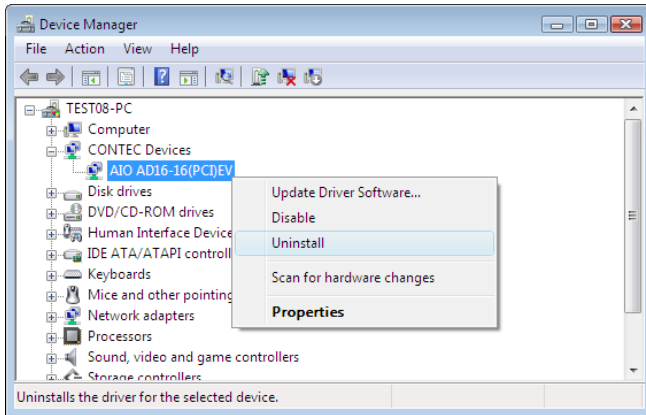

3. A dialog box opens asking you to confirm whether to uninstall. Select the [Delete the driver software for this device] checkbox, and then click [OK].

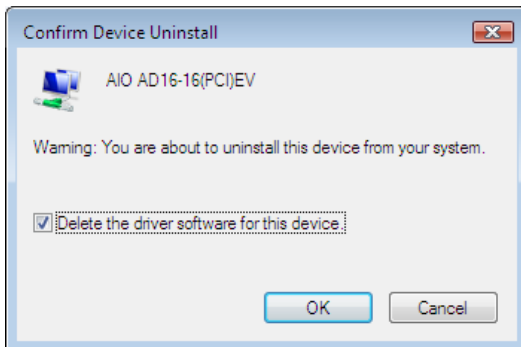

< Uninstall the development environment >

Use [My Computer] - [Control Panel] - [Programs and Features] to uninstall the development environment.

Select [CONTEC API-*** (WDM) VerX.XX (development environment)] and then click [Uninstall].

* "****" contains the driver category name (AIO, CNT, DIO, SMC, etc.).

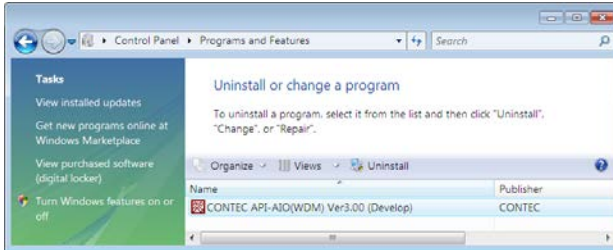

Uninstall procedure for Windows XP and Windows 2003 Server

< Uninstall the device driver >

Use [My Computer] - [Control Panel] - [Add and Remove Programs] to uninstall the device driver. Select [Windows driver package - CONTEC (****)] and then click [Change/Remove].

* "****" contains the driver category name (caio, cnt, cdio, csmc, etc.).

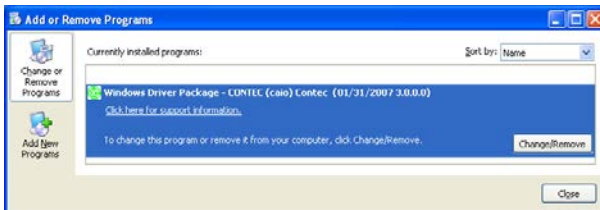

< Uninstall the development environment >

Use [My Computer] - [Control Panel] - [Add and Remove Programs] to uninstall the development environment.

Select [CONTEC API-*** (WDM) VerX.XX (development environment)] and then click [Change/Remove].

* "****" contains the driver category name (AIO, CNT, DIO, SMC, etc.).

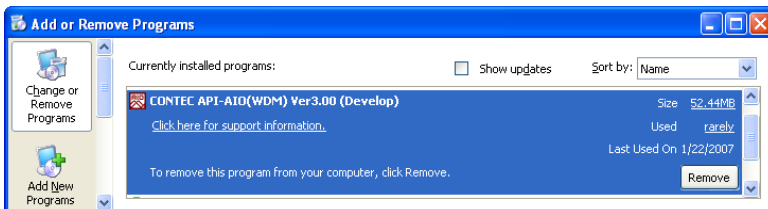

Uninstall procedure for Windows Me

< Uninstall the device driver >

Use [My Computer] - [Control Panel] - [Add and Remove Applications] to uninstall the device driver. Select [CONTEC API-***(WDM) driver] and then click [Add/Remove].

* "***" contains the driver category name (AIO, CNT, DIO, SMC, etc.).

< Uninstall the development environment >

Use [My Computer] - [Control Panel] - [Add and Remove Programs] to uninstall the development environment.

Select [CONTEC API-***(WDM) VerX.XX (development environment)] and then click [Add/Remove].

* "***" contains the driver category name (AIO, CNT, DIO, SMC, etc.).

Uninstall procedure for Windows 98, 98SecondEdition

< Uninstall the device driver >

Use [My Computer] - [Control Panel] - [Add and Remove Applications] to uninstall the device driver. Select [CONTEC API-***(WDM) driver] and then click [Add/Remove].

* "***" contains the driver category name (AIO, CNT, DIO, SMC, etc.).

< Uninstall the development environment >

Use [My Computer] - [Control Panel] - [Add and Remove Applications] to uninstall the development environment.

Select [CONTEC API-***(WDM) VerX.XX (development environment)] and then click [Add/Remove].

* "***" contains the driver category name (AIO, CNT, DIO, SMC, etc.).

About Software for Linux

The Linux version of digital I/O function driver, API-DIO(LNX), provides functions that execute the following features:

- Analog I/O of specified channels
- It is possible to operate as a set parameter to the analog I/O board is preserved by the default value, and the setting of the parameter doesn't exist.

For details, refer to the help file. The help file provides various items of information such as "Function Reference", "Sample Programs", and "FAQs". Use them for program development and troubleshooting.

Driver Software Install Procedure

The Linux version for analog I/O driver, API-AIO(LNX), is supplied as a compressed file /linux/aio/caioXXX.tgz on the bundled disk. (Note: XXX represents the driver version.)

Mount the bundled disk as shown below, copy the file to an arbitrary directory, and decompress the file to install the driver.

For details on using the driver, refer to readme.txt and the help file in HTML format extracted by installation.

To install the driver, log in as a superuser.

Decompression and setup procedure

```
# cd
# mount /dev/cdrom /mnt/cdrom           Mount the bundled disk.
# cp /mnt/cdrom/linux/aio/caioXXX.tgz ./  Copy the compressed file.
# tar xvfz caioXXX.tgz                 Decompress the compressed
file.
.....
# cd contec/caio
# make                                 Compile the file.
.....
# make install                         Install.
.....
# cd config
# ./config                             Set up the board to be used.
..... Set as follows.....
# ./contec_aio_start.sh                Start the driver.
# cd
```

Accessing the Help File

- (1) Invoke a web browser in your X-Window environment.
- (2) In the browser, open apitool.htm in the contec/caio/help directory.

Using Sample Programs

Sample programs have been prepared for specific basic applications. Sample programs for each language are contained in the contec/caio/samples directory. For compiling them, refer to the manual for the desired language.

Uninstalling the driver

To uninstall the driver, use the uninstall shell script contained in the contec/caio directory. For details, check the contents of the script.

6. About Hardware

This chapter provides hardware specifications and hardware-related supplementary information.

For detailed technical information

For further detailed technical information (“Technical Reference” including the information such as an I/O map, configuration register, etc.), visit the Contec's web site to call for it.

Hardware specification

Table 6.1. Specification

Item	Specification
Analog input	
Isolated specification	Un-Isolated
Input type	Single-Ended Input or Differential Input (by software)
Input channel	64ch (single-ended input), 32ch (differential input)
Input range	Bipolar $\pm 10V$
Absolute max. input voltage	$\pm 20V$
Input impedance	1M Ω or more
Resolution	16Bit
Non-Linearity error *1 *2	$\pm 5LSB$
Conversion speed	10 μ sec/ch
Buffer memory	1k Word
Conversion start trigger	Software / external trigger
Conversion stop trigger	Number of sampling times / external trigger / software
External start signal	LVTTL-level (Rising or falling edge can be selected by software) Digital filter (select 1 μ sec by software)
External stop signal	LVTTL-level (Rising or falling edge can be selected by software) Digital filter (select 1 μ sec by software)
External clock signal	LVTTL-level (Rising or falling edge can be selected by software)
Digital I/O	
Number of input channels	Un-Isolated input 4 channels (LVTTL-level positive logic)
Number of output channels	Un-Isolated output 4 channels (LVTTL-level positive logic)
Counter	
Number of channels	1ch
Counting system	Up count
Max. count	FFFFFFFFh (Binary data, 32bit)
Number of external inputs	2 LVTTL (Gate/Up) Gate (High level), Up (Rising edge)
Number of external outputs	LVTTL Count match output (positive logic, pulse output)
Response frequency	10MHz (Max.)
Common	
I/O address	64 ports boundary
Interruption level	Errors and various factors, One interrupt request line as INTA
Connector	68 pin 0.8mm pitch connector HDRA-E68W1LFDT-SL [HONDA] or equivalent to it
Power consumption	3.3VDC 620mA (Max.)
Operating condition	0 - 50°C, 10 - 90%RH (No condensation)
Bus specification	PCI Express Base Specification Rev. 1.0a x1
Dimension (mm)	121.69(L) x 67.90(H)
Weight	90g

*1: The non-linearity error means an error of approximately 0.1% occurs over the maximum range at 0°C and 50°C ambient temperature.

*2: At the time of the source use of a signal which built in the high-speed operational amplifier.

Board Dimensions

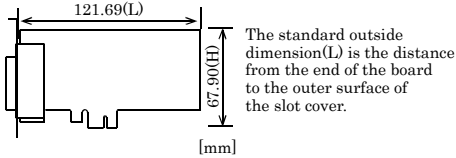

Block Diagram

Figure 6.1 is a circuit block diagram of this board.

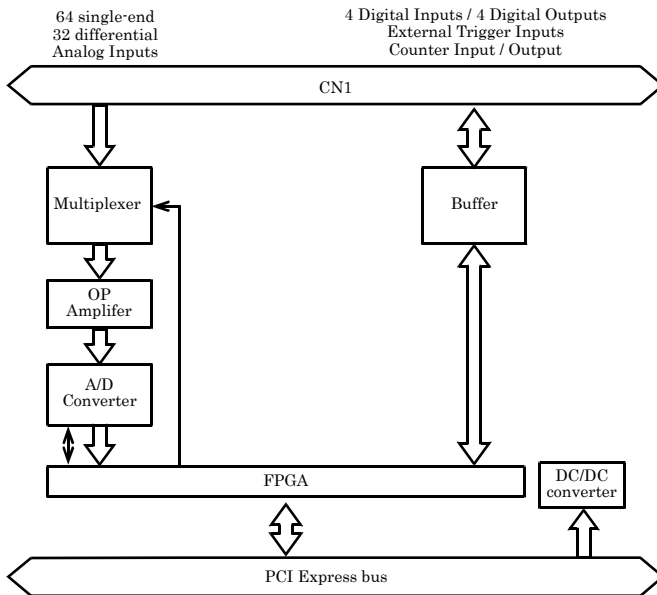

Figure 6.1. Block Diagram

Control Signal Timings

Control Signal Timings for Analog Input

Figures 6.2, 6.3, 6.4, and Table 6.2 show the control signal timings for the analog input function.

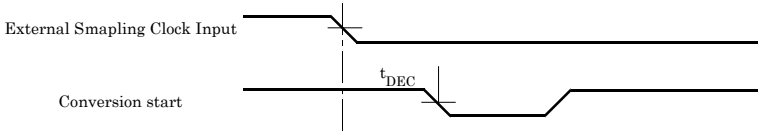

Figure 6.2. Timing Chart of External Sampling Clock

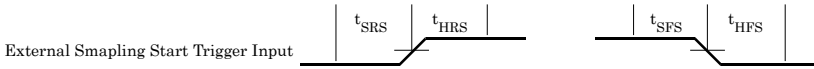

Figure 6.3. Timing Chart of Sampling Start Control Signal

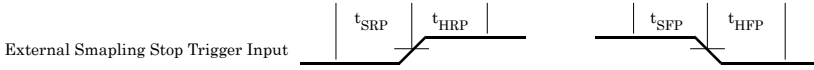

Figure 6.4. Timing Chart of Sampling Stop Control Signal

Table 6.2. Control Signal Timings

Parameter	Symbol	Time	Unit
Delay time from external sampling clock to first A/D start pulse	t _{DEC}	100	nsec
Set up time of sampling start (Rising edge)	t _{SRS}	100	nsec
Hold time of sampling start (Rising edge)	t _{HRS}	100	nsec
Set up time of sampling start (Falling edge)	t _{SFS}	100	nsec
Hold time of sampling start (Falling edge)	t _{HFS}	100	nsec
Set up time of sampling stop (Rising edge)	t _{SRP}	100	nsec
Hold time of sampling stop (Rising edge)	t _{HRP}	100	nsec
Set up time of sampling stop (Falling edge)	t _{SFP}	100	nsec
Hold time of sampling stop (Falling edge)	t _{HFP}	100	nsec

⚠ CAUTION

The times listed in Table 6.2 are for standard operating conditions.

Control Signal Timings for Analog Output

Figures 6.5, 6.6 and Table 6.3 show the control signal timings for the analog input function.



Figure 6.5. Timing Chart of Counter Input Signal

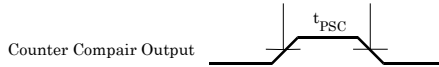

Figure 6.6. Timing Chart of Counter Output Signal (Pulse output)

Table 6.3. Control Signal Timings

Parameter	Symbol	Time	Unit
Set up time of counter input (Rising edge)	t_{SRC}	100	nsec
Hold time of sampling start (Rising edge)	t_{HRC}	100	nsec
Pulse width of counter output signal	t_{PSC}	1000	nsec



CAUTION

The times listed in Table 6.3 are for standard operating conditions.

About Calibration

Although this board is calibrated before shipping, you can use the calibration program to calibrate analog input yourself.

Starting the calibration program

Click the [Calibration] button on the property page for the device to start the calibration program.

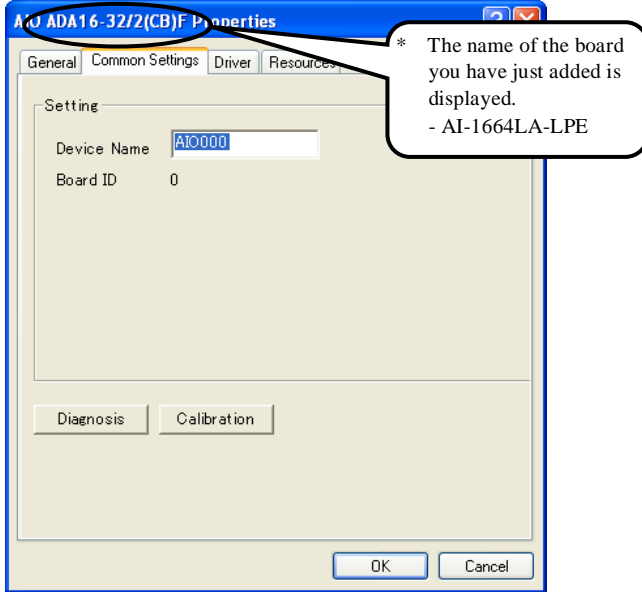

Proceed with connecting the calibration equipment and performing the calibration in accordance with the instructions displayed by the calibration program.

Analog input calibration

Analog input calibration requires a reference voltage generator.

As the analog input has 16-bit resolution, use a reference voltage generator with a precision of at least 5 digits after the decimal point.

Calibrate one channel only for each range that you use.

Factory setting

You can use the calibration program to restore the factory calibration settings.

Difference from AD16-64(LPCI)LA

The functions same with conventional product of AD16-64(LPCI)LA are provided with the AI-1664LA-LPE. In addition, as there is compatibility in terms of connector shape and pin assignments, it is easy to migrate from the existing system. So you can use the same operating procedures as AD16-64(LPCI)LA.

There are some differences in specifications as shown below.

	AI-1664LA-LPE	AD16-64(LPC)LA
Power consumption	+3.3VDC 620 mA (Max.)	+5VDC 450 mA (Max.)
Bus specification	PCI Express Base Specification Rev. 1.0a x1	PCI (32-bit, 33MHz, Universal key shapes supported)
External start signal	LVTTL-level	TTL-level
External stop signal	LVTTL-level	TTL-level
External clock signal	LVTTL-level	TTL-level
Digital Input/Output	LVTTL-level positive logic	TTL-level positive logic
External Counter Input/Output	LVTTL-level	TTL-level
Dimension (mm)	121.69 (L)×67.90(H)	121.69(L)×63.41(H)
Weight	90g	60g

AI-1664LA-LPE

User's Guide

CONTEC CO., LTD.

December 2017 Edition

3-9-31, Himesato, Nishiyodogawa-ku, Osaka 555-0025, Japan
<https://www.contec.com/>

No part of this document may be copied or reproduced in any form by any means without prior written consent of CONTEC CO., LTD. [12252017]

[03032008]

Management No. A-51-546

[12252017_rev3]

Parts No. LYJA373