

PC-HELPER

Isolated Analog Input Board  
for PCI

**AI-1604CI2-PCI**

User's Guide

CONTEC CO.,LTD.

---

# Check Your Package

---

Thank you for purchasing the CONTEC product.

The product consists of the items listed below.

Check, with the following list, that your package is complete. If you discover damaged or missing items, contact your retailer.

## Product Configuration List

- Board [AI-1604CI2-PCI] ...1
- First step guide ...1
- CD-ROM \*1 [API-PAC(W32)] ...1

\*1 The CD-ROM contains the driver software and User's Guide (this guide)

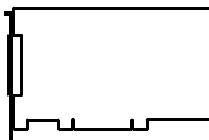

Board

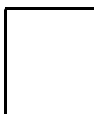

First step guide

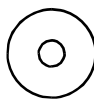

CD-ROM  
[API-PAC(W32)]

---

# Copyright

Copyright 2007 CONTEC CO., LTD. ALL RIGHTS RESERVED

No part of this document may be copied or reproduced in any form by any means without prior written consent of CONTEC CO., LTD.

CONTEC CO., LTD. makes no commitment to update or keep current the information contained in this document. The information in this document is subject to change without notice.

All relevant issues have been considered in the preparation of this document. Should you notice an omission or any questionable item in this document, please feel free to notify CONTEC CO., LTD.

Regardless of the foregoing statement, CONTEC assumes no responsibility for any errors that may appear in this document or for results obtained by the user as a result of using this product.

# Trademarks

MS, Microsoft, Windows and Windows NT are trademarks of Microsoft Corporation. Other brand and product names are trademarks of their respective holder.

---

# Table of Contents

Check Your Package .....	i
Copyright .....	ii
Trademarks .....	ii
Table of Contents .....	iii

<b>1. BEFORE USING THE PRODUCT</b>	<b>1</b>
------------------------------------	----------

About the Product .....	1
Features.....	1
Support Software.....	2
Cable & Connector (Option).....	3
Accessories (Option).....	3
Customer Support.....	4
Web Site .....	4
Limited Three-Years Warranty.....	4
How to Obtain Service.....	4
Liability .....	4
Safety Precautions .....	5
Safety Information .....	5
Handling Precautions.....	6
Environment .....	7
Inspection .....	7
Storage.....	7
Disposal .....	7

<b>2. SETUP</b>	<b>9</b>
-----------------	----------

What is Setup?.....	9
Using the Board under Windows Using the Driver Library API-PAC(W32).....	9
Using the Board under Windows Using Software Other than the Driver Library API-PAC(W32).....	9
Using the Board under an OS Other than Windows.....	10
Step 1 Installing the Software.....	11
About the driver to be used.....	11
Starting the Install Program .....	12
When Using API-AIO(WDM) .....	13
When Using API-AIO(98/PC) .....	14
Step 2 Setting the Hardware .....	16
Parts of the Board and Factory Defaults .....	16
Setting the Board ID .....	17
Setting the Analog Input.....	17
Plugging the Board.....	18

Step 3 Installing the Hardware.....	19
Turning on the PC .....	19
When Using the API-AIO(WDM).....	19
When Using API-AIO(98/PC).....	20
When Using API-AIO(98/PC).....	21
Step 4 Initializing the Software.....	24
When Using API-AIO(WDM).....	24
When Using API-DIO(98/PC).....	26
Step 5 Checking Operations with the Diagnosis Program.....	27
What is the Diagnosis Program?.....	27
Check Method.....	27
Using the Diagnosis Program for Use of API-AIO(WDM) .....	28
Using the Diagnosis Program for Use of API-AIO(98/PC) .....	30
Setup Troubleshooting.....	33
Symptoms and Actions.....	33
If your problem cannot be resolved .....	33

<b>3.</b>	<b>EXTERNAL CONNECTION</b>	<b>35</b>
-----------	----------------------------	-----------

How to connect the connectors .....	35
Connector shape .....	35
Connector Pin Assignment.....	36
Connecting the Analog Input Signal.....	37
Input Circuit of Analog Input Signal .....	37
Connection Example of Voltage Signal Source .....	38
Connection Example of Current Signal Source .....	39
Connecting the Control Signal.....	40
Connecting the Input Signal.....	40
Connecting the Output Signal .....	42
Surge Voltage Countermeasures.....	44

<b>4.</b>	<b>FUNCTIONS</b>	<b>45</b>
-----------	------------------	-----------

Analog Input Function.....	45
1. Setting the Conversion Conditions .....	46
2. Starting/Stopping Operation .....	52
3. Monitoring the Status and Acquiring Data.....	53
4. Reset.....	57

<b>5.</b>	<b>ABOUT SOFTWARE</b>	<b>59</b>
-----------	-----------------------	-----------

CD-ROM Directory Structure .....	59
About Software for Windows .....	60
When using the API-AIO(WDM).....	61
Accessing the Help File.....	61

Using Sample Programs.....	62
Usage of Utility Program.....	64
When using the API-AIO(98/PC).....	67
Accessing the Help File .....	67
Using Sample Programs.....	68
Using the Utility Program.....	70
Uninstalling the Driver Libraries.....	72
About Software for Linux.....	75
Driver Software Install Procedure.....	75
Accessing the Help File .....	76
Using Sample Programs.....	76
Uninstalling the driver .....	76

<b>6.</b>	<b>ABOUT HARDWARE</b>	<b>77</b>
-----------	-----------------------	-----------

For detailed technical information.....	77
Hardware specification .....	78
Block Diagram .....	79
Timing for Control Signal.....	80
Timing for External Sampling Clock and External Trigger Inputs.....	80
Timing for External Trigger Input and Input Status .....	80
Timing for External Sampling Clock Input and AD Conversion in Progress Output Signal .....	81
Timing for Timer Output .....	81
About Calibration.....	82
Difference from ADI16-4C(PCI)-N, ADI16-4C(PCI) .....	82



# 1. Before Using the Product

## About the Product

This product is a PCI bus supported board that extends the analog signal input functions of a PC. Equipped with four channels of 16bit analog input, this product is an individual isolation model that provides isolation for the bus line with PC and between channels. Voltage input and current input are set for each channel by jumper, while the voltage range is set by software. Windows/Linux driver is bundled with this product.

Using the dedicated library VI-DAQ makes it possible to create each application for LabVIEW.

## Features

- Analog input 4channel, 16bit-resolution, conversion speed  $20\mu\text{ sec}[50\text{KSPS}] / \text{ch}$

This product has the Analog input (4channel, 16bit,  $20\mu\text{ sec}[50\text{KSPS}] / \text{ch}$ ).

Additionally, the voltage input/current input switch is set by jumper and current range (voltage :  $\pm 10\text{V}$ ,  $\pm 5\text{V}$ ,  $0 - +10\text{V}$ ,  $0 - +5\text{V}$ ) is set by software for each channel.

- Individual isolation model that provides isolation for the bus line with PC and between channels.

The isolation amplifier provides electric isolation between channels as well as between the inside of the board (PC) and the input circuit. This allows signals with different ground levels to be input to the channels. The isolation voltage is 500V.

- Control of sampling start/stop can be selected by software, comparison of converted data, external trigger or other factor.

Control of sampling start can be selected by software, comparison of converted data, or external trigger (timing of a control signal entered from outside).

Control of sampling stop can be selected forcibly by completion of sampling sessions, comparison of converted data, external trigger, or software.

A sampling cycle can be selected from the internal clock (high precision timer mounted on the board) or an external clock (control signal entered from outside).

- Windows/Linux compatible driver libraries are attached.

Using the attached driver library API-PAC(W32) makes it possible to create applications of Windows/Linux. In addition, a diagnostic program by which the operations of hardware can be checked is provided.

- LabVIEW is supported by a plug-in of dedicated library VI-DAQ.

Using the dedicated library VI-DAQ makes it possible to create each application for LabVIEW.



## Support Software

You should use CONTEC support software according to your purpose and development environment.

### Windows version of analog I/O driver **API-AIO(WDM)/API-AIO(98/PC)**

[Stored on the bundled CD-ROM driver library API-PAC(W32)]

These drivers are the Windows version driver library software that provides products in the form of Win32 API functions (DLL). Various sample programs such as Visual Basic and Visual C++, etc and diagnostic program useful for checking operation is provided.

< Operating environment >

OS Windows Vista, XP, Server 2003, 2000

Adaptation language Visual Basic, Visual C++, Visual C#, Delphi, C++ Builder

For more details on the supported OS, applicable language and how to download the updated version, please visit the CONTEC's Web site (<http://www.contec.com/apipac/>).

### Linux version of analog I/O driver **API-AIO(LNX)**

[Stored on the bundled CD-ROM driver library API-PAC(W32)]

The API-AIO(LNX) is the Linux version driver software which provides device drivers (modules) by shared library and kernel version. Various sample programs of gcc are provided.

< Operating environment >

OS RedHatLinux, TurboLinux

(For details on supported distributions, refer to Help available after installation.)

Adaptation language gcc

For more details on the supported OS, applicable language and how to download the updated version, please visit the CONTEC's Web site (<http://www.contec.com/apipac/>).

### Data acquisition VI library for LabVIEW **VI-DAQ**

(Available for downloading (free of charge) from the CONTEC web site.)

This is a VI library to use in National Instruments LabVIEW.

VI-DAQ is created with a function form similar to that of LabVIEW's Data Acquisition VI, allowing you to use various devices without complicated settings.

See <http://www.contec.com/vidaq/> for details and download of VI-DAQ.

## Cable & Connector (Option)

Flat Cable with 37-Pin D-SUB Connector at One End	: PCA37P-1.5 (1.5m)
Shield Cable with 37-Pin D-SUB Connector at One End	: PCA37PS-0.5P (0.5m)
	: PCA37PS-1.5P (1.5m)
Flat Cable with 37-Pin D-SUB Connectors at either Ends	: PCB37P-1.5 (1.5m)
Shielded Cable with 37-pin D-SUB connectors at either ends	: PCB37PS-0.5P (0.5m)
	: PCB37PS-1.5P (1.5m)
37-pin D-SUB (Male) Connector Set (5 Pieces)	: CN5-D37M

## Accessories (Option)

Screw Terminal Unit (M3 x 37P)	: EPD-37A *1 *2
Screw Terminal Unit (M3.5 x 37P)	: EPD-37 *1
General Purpose Terminal (M3 x 37P)	: DTP-3A *1
Screw Terminal (M2.6 x 37P)	: DTP-4A *1

\*1 PCB37P-\* or PCB37PS-\* optional cable is required separately (0.5m is recommended.).

\*2 "Spring-up" type terminal is used to prevent terminal screws from falling off.

\* Check the CONTEC's Web site for more information on these options.

## Customer Support

CONTEC provides the following support services for you to use CONTEC products more efficiently and comfortably.

### Web Site

Japanese <http://www.contec.co.jp/>  
English <http://www.contec.com/>  
Chinese <http://www.contec.com.cn/>

### Latest product information

CONTEC provides up-to-date information on products.

CONTEC also provides product manuals and various technical documents in the PDF.

### Free download

You can download updated driver software and differential files as well as sample programs available in several languages.

### Note! For product information

Contact your retailer if you have any technical question about a CONTEC product or need its price, delivery time, or estimate information.

## Limited Three-Years Warranty

CONTEC products are warranted by CONTEC CO., LTD. to be free from defects in material and workmanship for up to three years from the date of purchase by the original purchaser.

Repair will be free of charge only when this device is returned freight prepaid with a copy of the original invoice and a Return Merchandise Authorization to the distributor or the CONTEC group office, from which it was purchased.

This warranty is not applicable for scratches or normal wear, but only for the electronic circuitry and original products. The warranty is not applicable if the device has been tampered with or damaged through abuse, mistreatment, neglect, or unreasonable use, or if the original invoice is not included, in which case repairs will be considered beyond the warranty policy.

## How to Obtain Service

For replacement or repair, return the device freight prepaid, with a copy of the original invoice. Please obtain a Return Merchandise Authorization number (RMA) from the CONTEC group office where you purchased before returning any product.

\* No product will be accepted by CONTEC group without the RMA number.

## Liability



The obligation of the warrantor is solely to repair or replace the product. In no event will the warrantor be liable for any incidental or consequential damages due to such defect or consequences that arise from inexperienced usage, misuse, or malfunction of this device.

# Safety Precautions

Understand the following definitions and precautions to use the product safely.

## Safety Information

This document provides safety information using the following symbols to prevent accidents resulting in injury or death and the destruction of equipment and resources. Understand the meanings of these labels to operate the equipment safely.

 DANGER	DANGER indicates an imminently hazardous situation which, if not avoided, will result in death or serious injury.
 WARNING	WARNING indicates a potentially hazardous situation which, if not avoided, could result in death or serious injury.
 CAUTION	CAUTION indicates a potentially hazardous situation which, if not avoided, may result in minor or moderate injury or in property damage.

## Handling Precautions

### DANGER

---

Do not use the product where it is exposed to flammable or corrosive gas. Doing so may result in an explosion, fire, electric shock, or failure.

---

### CAUTION

---

- There are switches and jumpers on this product that need to be set in advance. Be sure to check these before installing this product.
  - Only set the switches and jumpers on this product to the specified settings. Otherwise, this product may malfunction, overheat, or cause a failure.
  - Do not strike or bend this product. Otherwise, this product may malfunction, overheat, cause a failure or breakage.
  - Do not touch this product's metal plated terminals (edge connector) with your hands. Otherwise, this product may malfunction, overheat, or cause a failure. If the terminals are touched by someone's hands, clean the terminals with industrial alcohol.
  - Do not install this product to the expansion slot and do not plug or unplug the cables which are connected to this product while the PC or expansion unit is still turned on. Otherwise, this product may malfunction, overheat, or cause a failure. Be sure that the personal computer power is turned off.
  - Make sure that your PC or expansion unit can supply ample power to all the products installed. Insufficiently energized products could malfunction, overheat, or cause a failure.
  - The specifications of this product are subject to change without notice for enhancement and quality improvement. Even when using the product continuously, be sure to read the manual and understand the contents.
  - Do not modify the product. CONTEC will bear no responsibility for any problems, etc., resulting from modifying this product.
  - Regardless of the foregoing statements, CONTEC is not liable for any damages whatsoever (including damages for loss of business profits) arising out of the use or inability to use this CONTEC product or the information contained herein.
-

## Environment

Use this product in the following environment. If used in an unauthorized environment, the product may overheat, malfunction, or cause a failure.

Operating temperature

0 - 50°C

Operating humidity

10 - 90%RH (No condensation)

Corrosive gases

None

Floating dust particles

Not to be excessive

## Inspection

Inspect the product periodically as follows to use it safely.

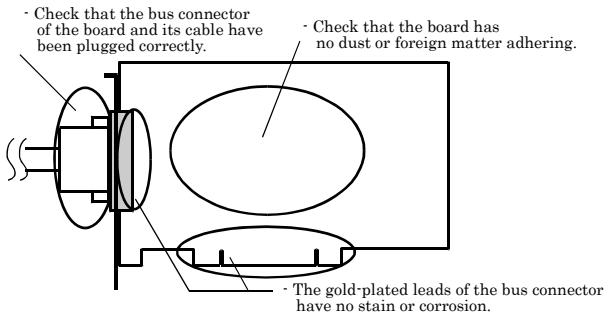

## Storage

When storing this product, keep it in its original packing form.

- (1) Put the product in the storage bag.
- (2) Wrap it in the packing material, then put it in the box.
- (3) Store the package at room temperature at a place free from direct sunlight, moisture, shock, vibration, magnetism, and static electricity.

## Disposal

When disposing of the product, follow the disposal procedures stipulated under the relevant laws and municipal ordinances.



## 2. Setup

This chapter explains how to set up the board.

### What is Setup?

Setup means a series of steps to take before the product can be used.

Different steps are required for software and hardware.

The setup procedure varies with the OS and applications used.

### Using the Board under Windows

#### Using the Driver Library API-PAC(W32)

This section describes the setup procedure to be performed before you can start developing application programs for the board using the bundled CD-ROM “Driver Library API-PAC(W32)”.

Taking the following steps sets up the software and hardware. You can use the diagnosis program later to check whether the software and hardware function normally.

**Step 1 Installing the Software**

**Step 2 Setting the Hardware**

**Step 3 Installing the Hardware**

**Step 4 Initializing the Software**

**Step 5 Checking Operations with the Diagnosis Program**

If Setup fails to be performed normally, see the “Setup Troubleshooting” section at the end of this chapter.

### Using the Board under Windows

#### Using Software Other than the Driver Library API-PAC(W32)

For setting up software other than API-PAC(W32), refer to the manual for that software. See also the following parts of this manual as required.

**This chapter Step 2 Setting the Hardware**

**This chapter Step 3 Installing the Hardware**

**Chapter 3 External Connection**

**Chapter 6 About Hardware**



## Using the Board under an OS Other than Windows

For using the board under Linux, see the following parts of this manual.

**This chapter Step 2 Setting the Hardware**

**Chapter 3 External Connection**

**Chapter 5 About Software**

**Chapter 6 About Hardware**

For using the board under an OS other than Windows and Linux, see the following parts of this manual.

**This chapter Step 2 Setting the Hardware**

**Chapter 3 External Connection**

**Chapter 6 About Hardware**

## Step 1 Installing the Software

This section describes how to install the Driver libraries.

**Before installing the hardware on the PC, install the driver library from the API-PAC(W32) CD-ROM provided with the board.**

The following description assumes the operating system as Windows XP. Although some user interfaces are different depending on the OS used, the basic procedure is the same.

### About the driver to be used

Two Analog I/O drivers are available : API-AIO(WDM) and API-AIO(98/PC).

API-AIO(WDM) is a new driver to perform analog I/O under Windows.

API-AIO(WDM) was developed to improve the conventional product version of API-AIO(98/PC) in the ease of use and functionality.

It is advisable to use API-AIO(WDM) for you to use an analog I/O device. API-AIO(WDM) will support new OS and devices in the future but will not support Windows NT 4.0, Windows 95, ISA bus. Use API-AIO(98/PC) if your operating environment contains such an unsupported piece of software or hardware.

Check the following selection guide to easily select the driver to be used.

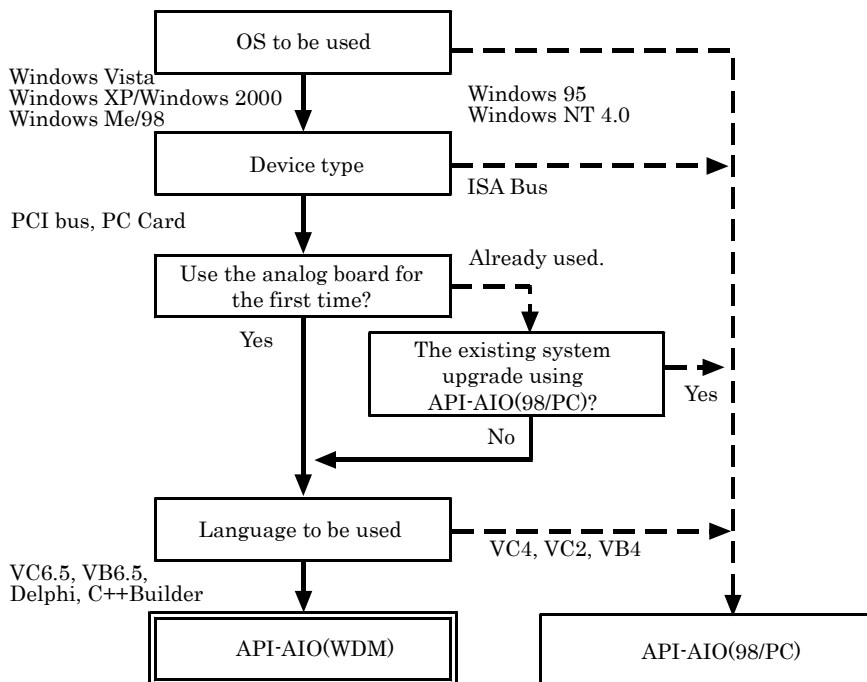

## Starting the Install Program

- (1) Load the CD-ROM [API-PAC(W32)] on your PC.
- (2) The API-PAC(W32) Installer window appears automatically.  
If the panel does not appear, run (CD-ROM drive letter):\AUTORUN.exe.
- (3) Click on the [Install Development or Execution Environment] button.

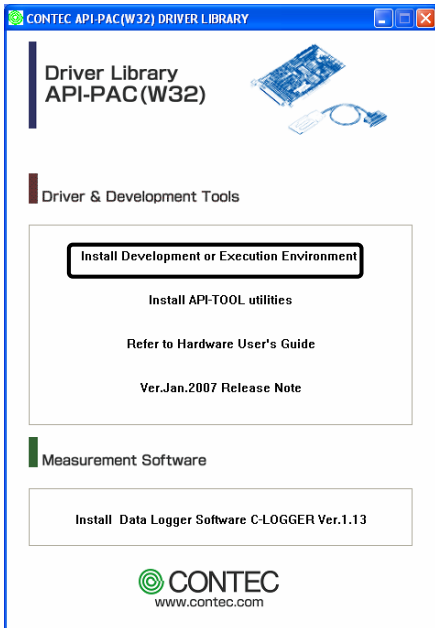

\* When using the Windows Vista, driver is automatically installed.

### CAUTION

Before installing the software in Windows Vista, XP, Server 2003, 2000, log in as a user with administrator privileges.

---

## When Using API-AIO(WDM)

Selecting API-AIO(WDM)

- (1) The following dialog box appears to select “Driver to install” and “Install option”, “Usage of driver library”.
- (2) Select the "Advanced Analog I/O driver".
- (3) Click on the [Install] button.

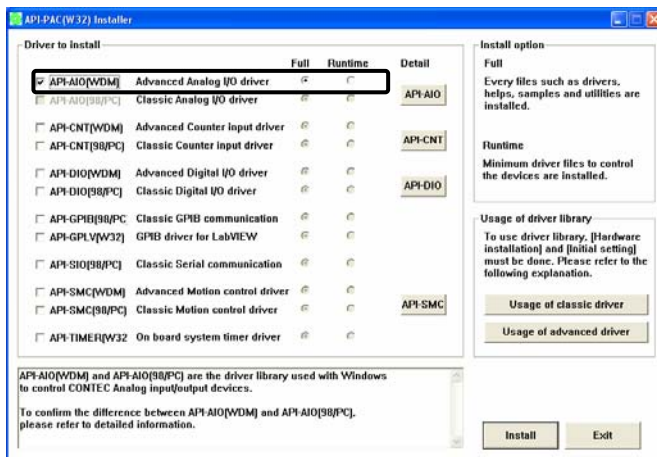

- \* Clicking the [API-AIO] button under the “Detail” displays detailed information about API-AIO(WDM) and API-AIO(98/PC).

Run the installation

- (1) Complete the installation by following the instructions on the screen.
- (2) The Readme file appears when the installation is complete.

## When Using API-AIO(98/PC)

Selecting API-AIO(98/PC)

- (1) The following dialog box appears to select “Driver to install” and “Install option”, “Usage of driver library”.
- (2) Select “Classic Analog I/O driver”.
- (3) Click on the [Install] button.

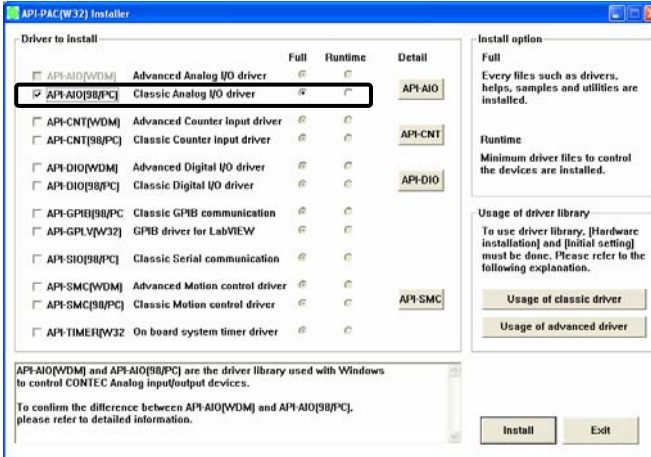

- \* Clicking the [API-AIO] button under the “Detail” displays detailed information about API-AIO(WDM) and API-AIO(98/PC).

## Executing the Installation

- (1) **Follow the on-screen instructions to proceed to install.**
- (2) When the required files have been copied, the “Perform a hardware setup now(API-TOOL Configuration)” and “Show readme file” check boxes are displayed.

**When you are installing the software or hardware for the first time:**

1) **Uncheck “Perform a hardware setup now”.**

2) **Click on the [Finish] button.**

**Go to Step 2 to set and plug the hardware.**

\* When the hardware has already been installed:

Check “Perform a hardware setup now(API-TOOL Configuration)”, then go to Step 4 “Initializing the Software”.

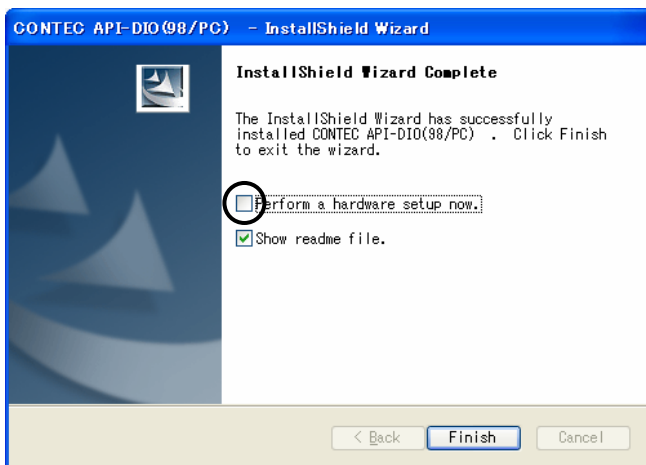

**You have now finished installing the software.**

## Step 2 Setting the Hardware

This section describes how to set this product and plug it on your PC.

This product has some switches to be preset.

Check the on-board switches before plugging this product into an expansion slot.

This product can be set up even with the factory defaults untouched. You can change board settings later.

### Parts of the Board and Factory Defaults

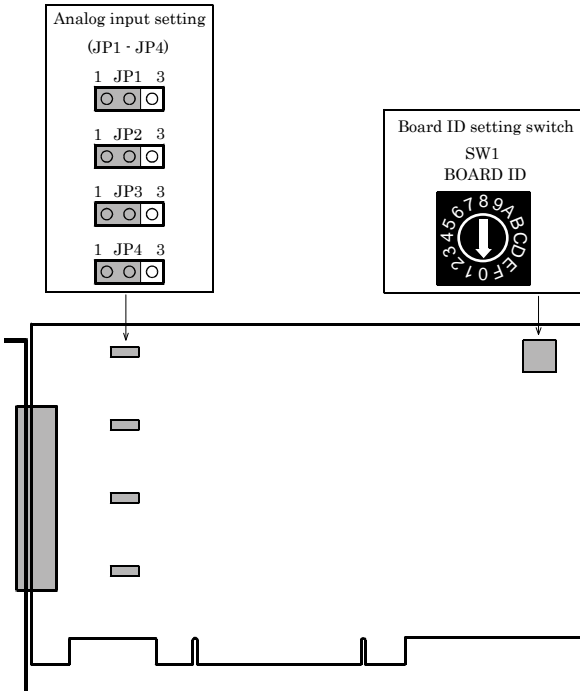

**Figure 2.1. Part Names**

Note that the jumper and switch setting shown below is the factory default.

## Setting the Board ID

If you install two or more boards on one personal computer, assign a different ID value to each of the boards to distinguish them.

The board IDs can be set from 0 - Fh to identify up to sixteen boards.

If only one board is used, the original factory setting (Board ID = 0) should be used.

### Setting Procedure

To set the board ID, use the rotary switch on the board. Turn the SW1 knob to set the board ID as shown below.

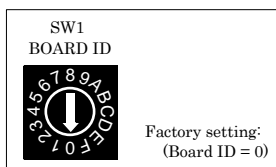

**Figure 2.2. Board ID Settings (SW1)**

## Setting the Analog Input

The board allows you to select the voltage or current input for each channel using their respective jumpers.

Set JP1 - JP4 on the board as illustrated below. Each channel is factory-set to voltage input.

### - Channel0 setting

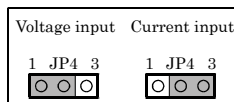

### - Channel1 setting

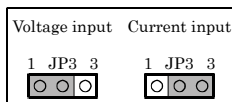

### - Channel2 setting

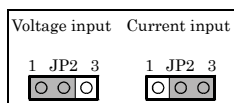

### - Channel3 setting

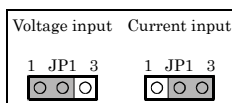

**Figure 2.3. Analog input setting**



## Plugging the Board

- (1) Before plugging the board, shut down the system, unplug the power cord of your PC.
- (2) Remove the cover from the PC so that the board can be mounted.
- (3) Plug the board into an expansion slot.
- (4) Attach the board bracket to the PC with a screw.
- (5) Put the cover back into place.



### Applicable PCI bus slots

PCI bus slots used in PCs have keys to prevent 5V and 3.3V PCI bus boards from being accidentally plugged into wrong bus slots. This board can be plugged into both of the 5V and 3.3V PCI bus slots.

<PCI bus slot>

5-V PCI bus slot

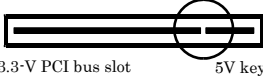

3.3-V PCI bus slot

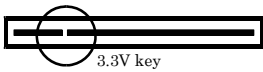

<PCI bus board>

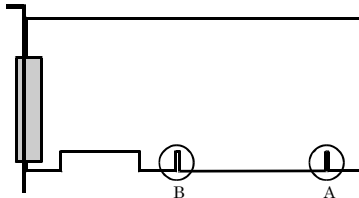

A : Slit for 5-V PCI bus slot  
B : Slit for 3.3-V PCI bus slot

### ⚠ CAUTION

- Do not touch the board's metal plated terminals (edge connector) with your hands. Otherwise, the board may malfunction, overheat, or cause a failure. If the terminals are touched by someone's hands, clean the terminals with industrial alcohol.
- Do not install or remove the board to or from the slot while the computer's power is turned on. Otherwise, the board may malfunction, overheat, or cause a failure. Doing so could cause trouble. Be sure that the personal computer or the I/O expansion unit power is turned off.
- Make sure that your PC or expansion unit can supply ample power to all the boards installed. Insufficiently energized boards could malfunction, overheat, or cause a failure.
- Power supply from the PCI bus slot at +5V is required.

## Step 3 Installing the Hardware

Windows needs to detect the I/O address and interrupt used by the board. This is called hardware installation.

When using more than one board, install the boards one at a time and do not install the next board until setup is complete for the previous board.

### Turning on the PC

Turn on the power to your PC.



#### CAUTION

- The board cannot be properly installed unless the resources (I/O addresses and interrupt level) for the board can be allocated. Before attempting to install the board, first determine what PC resources are free to use.
- The resources used by each board do not depend on the location of the PCI bus slot or the board itself. If you remove two or more boards that have already been installed and then remount one of them on the computer, it is unknown that which one of the sets of resources previously assigned to the two boards is assigned to the remounted board. In this case, you must check the resource settings.

### When Using the API-AIO(WDM)

- (1) The “Found New Hardware Wizard” will be started.  
Select “Install from a list or specific location[Advanced]”, then click on the [Next] button.



- (2) Specify that folder on the CD-ROM which contains the setup information (INF) file to register the board.



**CAUTION**

Note that the displayed board name is "ADI16-4C(PCI)" even though you have installed this board. There is no problem in operation even if the board name is displayed as "ADI16-4C(PCI)".

**Source folder**

The setup information (INF) file is contained in the following folder on the bundled CD-ROM.

\INF\WDM\AIO

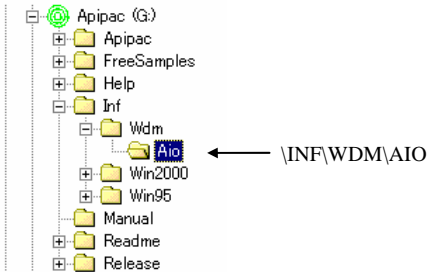

**You have now finished installing the hardware.**

## When Using API-AIO(98/PC)

- (1) The “Found New Hardware Wizard” will be started.  
 Select “Install from a list or specific location[Advanced]”, then click on the [Next] button.  
**If you are using Windows NT 4.0, the “Found New Hardware Wizard” is not started.  
 Go to Step 4 “Initializing the Software”.**



- (2) Specify that folder on the CD-ROM which contains the setup information (INF) file to register the board.

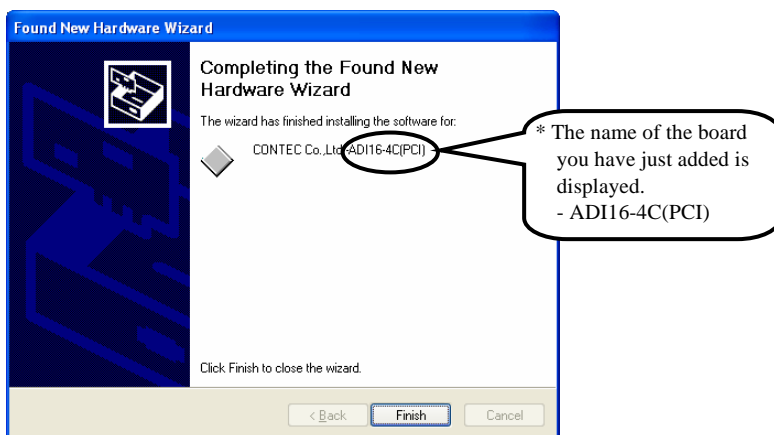

### ⚠ CAUTION

Note that the displayed board name is "ADI16-4C(PCI)" even though you have installed this board.  
 There is no problem in operation even if the board name is displayed as "ADI16-4C(PCI)".

### Source folder

The setup information (INF) file is contained in the following folder on the bundled CD-ROM.

Windows Vista	\\INF\\WinVista\\Aio\\PCI
Windows XP, Server 2003, 2000	\\INF\\Win2000\\Aio\\PCI
Windows Me, 98, 95	\\INF\\Win95\\Aio\\PCI

### Example of specifying the folder for use under Windows XP

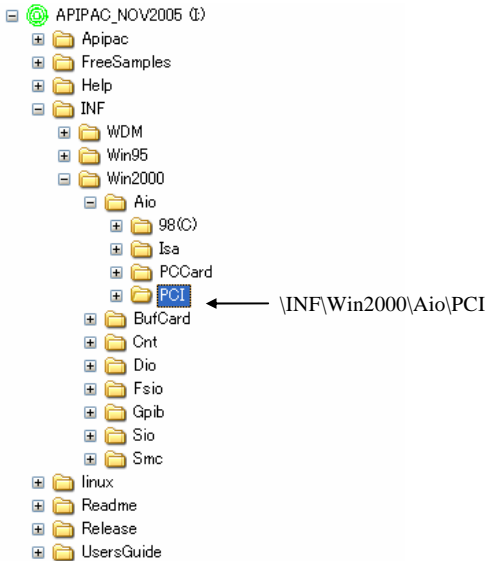

---

**⚠ CAUTION**

- In Windows XP, the Hardware Wizard displays the following alert dialog box when you have located the INF file. This dialog box appears, only indicating that the relevant driver has not passed Windows Logo testing, and it can be ignored without developing any problem with the operation of the board.

**In this case, click on the [Continue Anyway] button.**

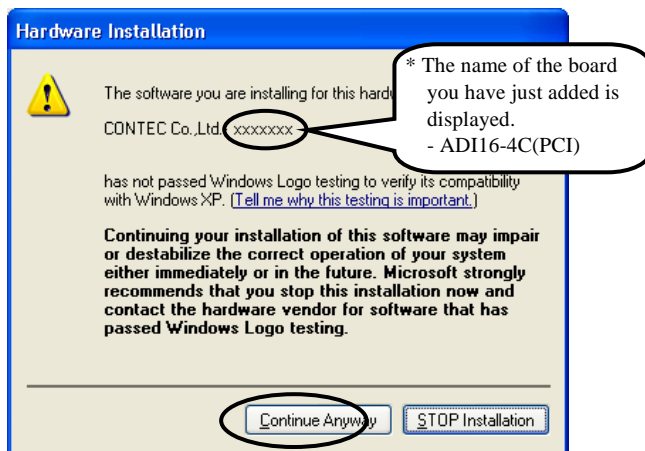

- Note that the displayed board name is "ADI16-4C(PCI)" even though you have installed this board. There is no problem in operation even if the board name is displayed as "ADI16-4C(PCI)".
- 

**You have now finished installing the hardware.**

## Step 4 Initializing the Software

The driver library requires the initial setting to recognize the execution environment. It is called the initialization of the driver library.

### When Using API-AIO(WDM)

Setting the device name

- (1) Run Device Manager. From [My Computer] - [Control Panel], select [System] and then select the [Device Manager] tab.  
(You can also open Device Manager by right clicking on My Computer and selecting Properties.)

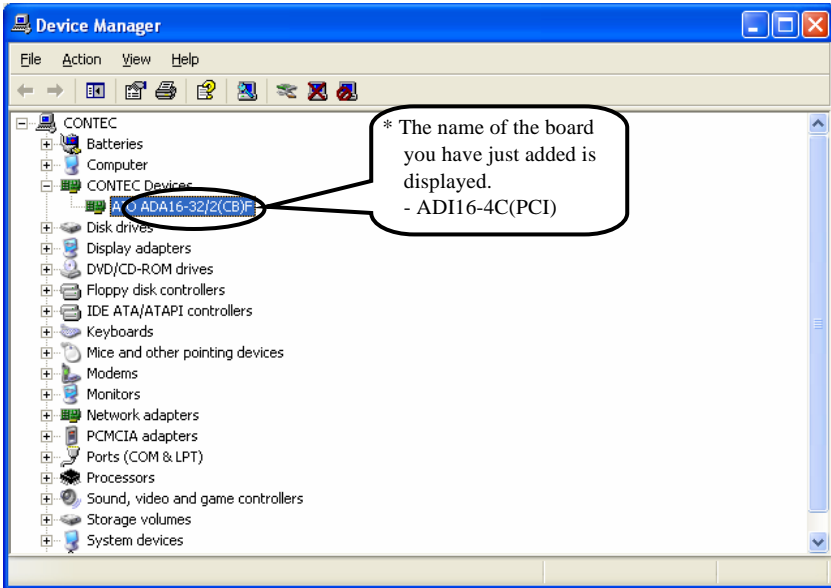

### ⚠ CAUTION

Note that the displayed board name is "ADI16-4C(PCI)" even though you have installed this board. There is no problem in operation even if the board name is displayed as "ADI16-4C(PCI)".

- (2) The installed hardware appears under the CONTEC Devices node. Open the CONTEC Devices node and select the device you want to setup (the device name should appear highlighted). Click [Properties].

(3) The property page for the device opens.

Enter the device name in the common settings tab page and then click [OK].

The device name you set here is used later when programming.

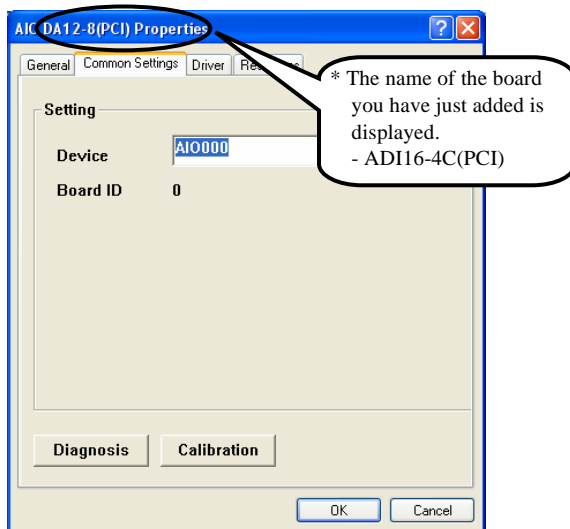

- \* The initial device name that appears is a default value. You can use this default name if you wish.
- \* Make sure that you do not use the same name for more than one device.



## CAUTION

Note that the displayed board name is "ADI16-4C(PCI)" even though you have installed this board. There is no problem in operation even if the board name is displayed as "ADI16-4C(PCI)".

**You have now finished installing the initial setting of Software.**



## When Using API-DIO(98/PC)

API-TOOL Configuration start

- (1) Open the Start Menu, then select “Programs” – “CONTEC API-PAC(W32)” – “API-TOOL Configuration”.

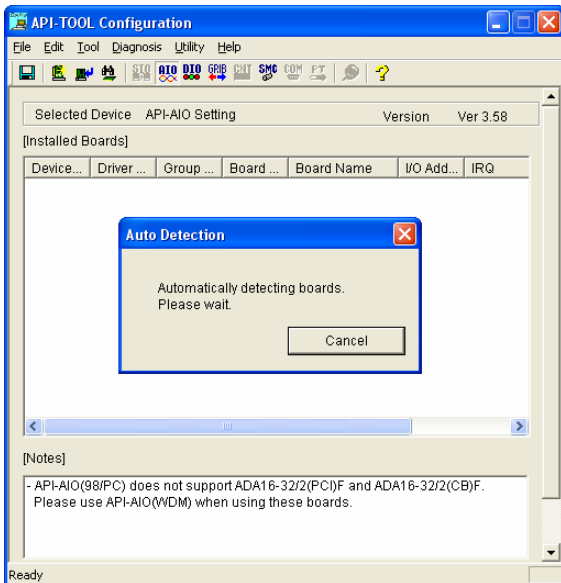

- (2) API-TOOL Configuration detects boards automatically.  
The detected boards are listed.

Updating the Settings

- (1) Select “Save setting to registry...” from the “File” menu.

**You have now finished installing the initial setting of Software.**

## Step 5 Checking Operations with the Diagnosis Program

Use the diagnosis program to check that the board and driver software work normally, thereby you can confirm that they have been set up correctly.

### What is the Diagnosis Program?

The diagnosis program diagnoses the states of the board and driver software.

It can also be used as a simple checker when an external device is actually connected.

Using the “Diagnosis Report” feature reports the driver settings, the presence or absence of the board, I/O status, and interrupt status.

### Check Method

To check analog input data, connect the signal.

The diagrams below show examples of using channel 0 on this product. For details on the connections, see Chapter 3 “External Connection”. Check the board with the factory defaults untouched.

#### Wiring Diagram

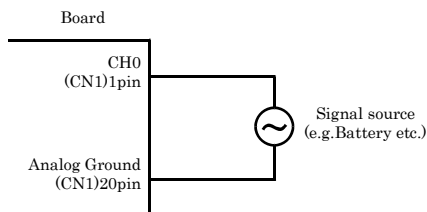

**Figure 2.4. Wiring Diagram**



#### CAUTION

Input data remains indeterminate when no input pin is connected. The input pin for the channel not connected to the signal source must be connected to the analog ground. For details, see “Chapter 3 Analog Input Signal Connection”.

## Using the Diagnosis Program for Use of API-AIO(WDM)

Starting the Diagnosis Program

Click the [Diagnosis] button on the device property page to start the diagnosis program.

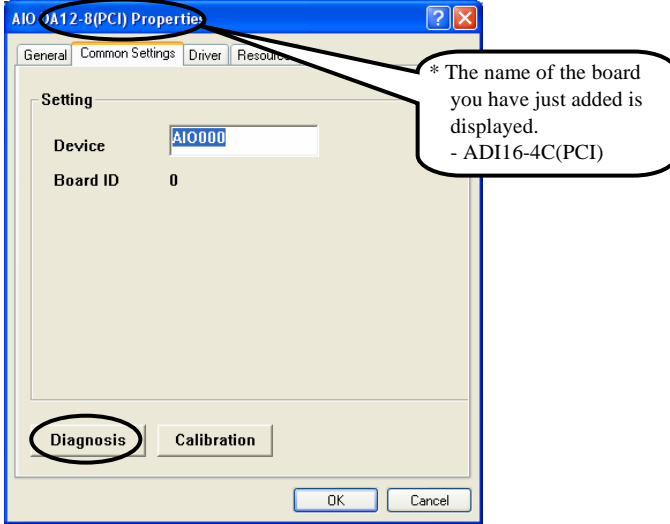

### ⚠ CAUTION

Note that the displayed board name is "ADI16-4C(PCI)" even though you have installed this board. There is no problem in operation even if the board name is displayed as "ADI16-4C(PCI)".

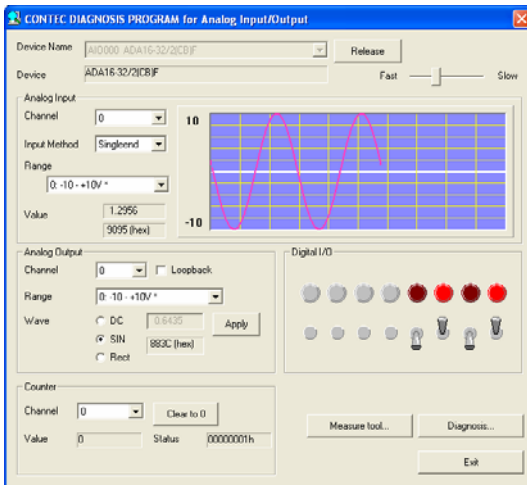

## Analog input

You can select the desired input channel, input mode and input range from the lists.  
Input data is plotted on a graph.

## Diagnosis Report

- (1) The diagnosis report saves detailed data, including the device settings and settings for each channel, to a text file and displays the file for you to view.

Clicking [Diagnosis Report] prompts you to specify where to save the report text file.

```

C:\>C:\Program Files\CONTEC\AI0000\AI0000\AI0000.exe
-----
CONTEC Analog I/O diagnostic report
-----
** CAIOdiag.exe program **
Date:2004/05/06 07:08:09
OS :Microsoft Windows XP 5.1.2600 Service Pack 1

[Device information]
Device Name AI0000
Device ADAL6-32(CB)F

[File Information]
G:\WINDOWS\SYSTEM32\CAIO.DLL 1, 3, 0, 0 2003/10/26 01:13
G:\WINDOWS\SYSTEM32\CAIOESS.OCX 1, 0, 0, 0 2003/10/26 01:13
G:\WINDOWS\SYSTEM32\CAIODEL.EXE 1, 1, 3, 0 2003/05/29 01:13
G:\WINDOWS\SYSTEM32\CAIOPP32.DLL 1, 1, 2, 0 2003/08/27 01:12
G:\WINDOWS\SYSTEM32\DRIVERS\CAIO.SYS 1, 1, 2, 0 2003/10/31 01:30
G:\WINDOWS\SYSTEM32\CAIODIAG.EXE 1, 1, 4, 0 2003/10/31 01:14

[diagnosis]
Initial result [0] Normality completion
Interrupt [0] Normality completion

Analog input 32CH
Input method:singleend
Ch00 [0] Normality completion DATA: 3.74(AFE4hex) RANGE:-10 - +10V
Ch01 [0] Normality completion DATA: 0.16(8200hex) RANGE:-10 - +10V
Ch02 [0] Normality completion DATA: -0.70(7701hex) RANGE:-10 - +10V
Ch03 [0] Normality completion DATA: -0.33(7530hex) RANGE:-10 - +10V
Ch04 [0] Normality completion DATA: -0.93(7416hex) RANGE:-10 - +10V
Ch05 [0] Normality completion DATA: -0.73(7659hex) RANGE:-10 - +10V
Ch06 [0] Normality completion DATA: -0.63(77C6hex) RANGE:-10 - +10V
Ch07 [0] Normality completion DATA: -0.28(7C6Dhex) RANGE:-10 - +10V
Ch08 [0] Normality completion DATA: -0.86(7506hex) RANGE:-10 - +10V
Ch09 [0] Normality completion DATA: -0.77(7623hex) RANGE:-10 - +10V
Ch10 [0] Normality completion DATA: -0.43(7A84hex) RANGE:-10 - +10V
Ch11 [0] Normality completion DATA: -0.21(7D50hex) RANGE:-10 - +10V
Ch12 [0] Normality completion DATA: -0.38(7B32hex) RANGE:-10 - +10V
Ch13 [0] Normality completion DATA: -0.16(7D6Fhex) RANGE:-10 - +10V
Ch14 [0] Normality completion DATA: -0.12(7E77hex) RANGE:-10 - +10V
Ch15 [0] Normality completion DATA: -0.34(7B41hex) RANGE:-10 - +10V
Ch16 [0] Normality completion DATA: -0.34(7944hex) RANGE:-10 - +10V
Ch17 [0] Normality completion DATA: -0.44(7A52hex) RANGE:-10 - +10V
Ch18 [0] Normality completion DATA: -0.52(794chex) RANGE:-10 - +10V
Ch19 [0] Normality completion DATA: -0.41(7AC4hex) RANGE:-10 - +10V
Ch20 [0] Normality completion DATA: -0.68(7747hex) RANGE:-10 - +10V
Ch21 [0] Normality completion DATA: -0.39(7AF6hex) RANGE:-10 - +10V
  
```

## ⚠ CAUTION

Note that the displayed board name is "ADI16-4C(PCI)" even though you have installed this board.  
There is no problem in operation even if the board name is displayed as "ADI16-4C(PCI)".

(2) The diagnosis report contains the following data.

- Version of OS
- Device Information
- File Information
- Diagnosis results for each input channel

Execution time measurement

Clicking [Execution Time Measurement] runs the program to measure API function execution speed. The operation of this program is explained in "API function Execution Speed Measurement Program" in Chapter 5.

## Using the Diagnosis Program for Use of API-AIO(98/PC)

Starting the Diagnosis Program

After selecting the board in [API-TOOL Configuration], run the diagnosis program. Follow the on-screen instructions.

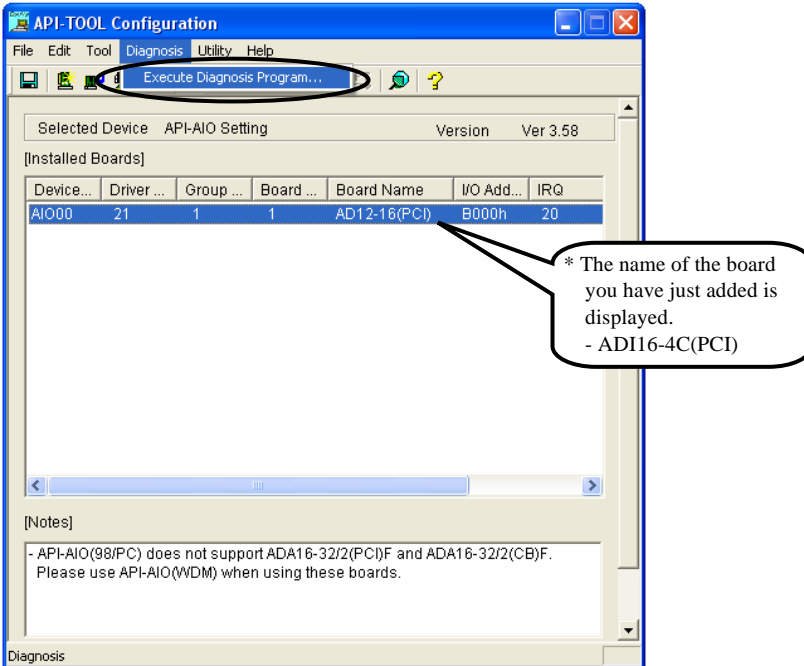

### CAUTION

Note that the displayed board name is "ADI16-4C(PCI)" even though you have installed this board. There is no problem in operation even if the board name is displayed as "ADI16-4C(PCI)".

## Checking the Analog Input

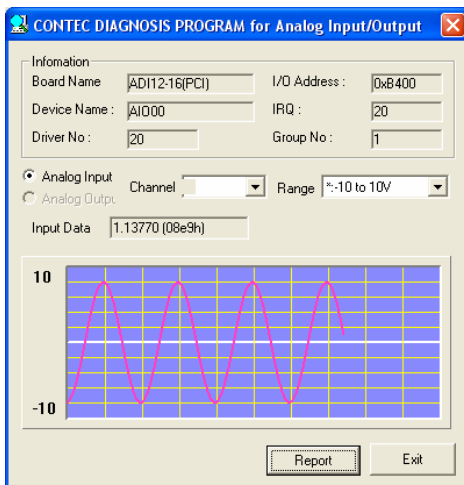

### Analog input

You can select the input channel and input range from the lists.

Input data is plotted on a graph.

### Diagnosis Report

- (1) Clicking on the [Report] button displays detailed data such as a board, channel settings and the diagnosis results while saving them in text format.

The results are saved and displayed as a text file (AioRep.txt) in the install folder (CONTEC/CONTECW95).

The Diagnosis Program performs “board presence/absence check”, “interrupt test”, “driver file test”, “board setting test”, and so on.

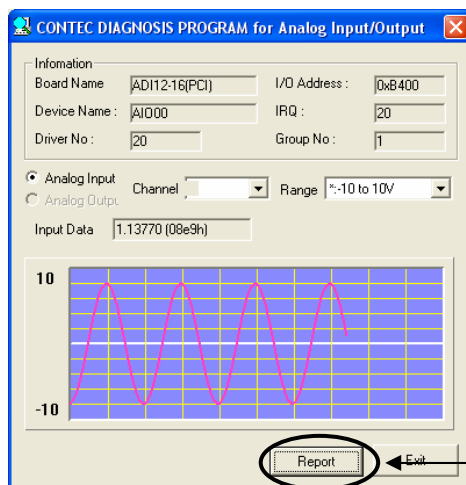

Click on [Report].

(2) A diagnosis report is displayed as shown below.

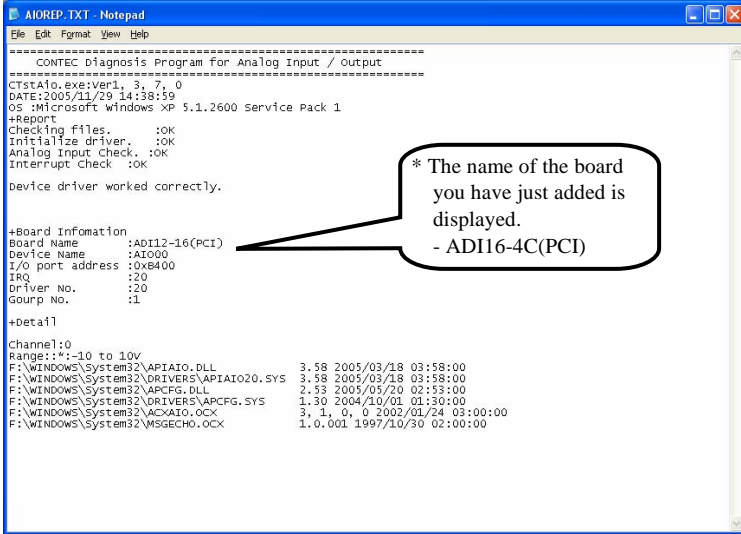

```
AI0REP.TXT - Notepad
File Edit Format View Help
=====
CONTEC Diagnosis Program For Analog Input / Output
=====
CTSTA10.exe:ver1 3, 7, 0
DATE:2005/11/29 14:38:59
OS :Microsoft Windows XP 5.1.2600 Service Pack 1
+Report
Checking files. :OK
Initialize driver. :OK
Analog Input Check. :OK
Interrupt Check :OK

Device driver worked correctly.

+Board Infomation
Board Name      :ADI12-16(PCI)
Device Name     :AI000
I/O port address :0x8400
IRQ             :20
Driver No.     :20
Gourp No.      :1

+Detail
Channel:0
Range:**4-10 to 10V
F:\WINDOWS\System32\APIAIO.DLL          3.58 2005/03/18 03:58:00
F:\WINDOWS\System32\DRIVERS\APIAIO20.SYS 3.58 2005/03/18 03:58:00
F:\WINDOWS\System32\APCFG.DLL          2.53 2005/05/20 02:53:00
F:\WINDOWS\System32\DRIVERS\APCFG.SYS  1.30 2004/10/01 01:30:00
F:\WINDOWS\System32\ACXAI0.OCX        3, 1, 0, 0 2002/01/24 03:00:00
F:\WINDOWS\System32\MSGECHO.OCX       1.0.001 1997/10/30 02:00:00
```

**⚠ CAUTION**

Note that the displayed board name is "ADI16-4C(PCI)" even though you have installed this board. There is no problem in operation even if the board name is displayed as "ADI16-4C(PCI)".

---

# Setup Troubleshooting

## Symptoms and Actions

The board cannot be initialized. [Windows NT 4.0]

The driver may not yet be activated. When your PC is running under Windows NT 4.0, set the PnP OS option in the BIOS Setup menu to "NO".

For details on BIOS settings, refer to the user's guide for your PC.

The board cannot input or output data normally

- Run the Diagnosis Program to check whether the board has been registered correctly and whether any initialization error has occurred.
- Check the settings and connections of the board. Also check the input and output ranges. When your board uses jumpers to set the input/output ranges, correct data cannot be obtained unless the ranges have been adjusted. When no connection has been made, input data remains indeterminate. The channel to be used must be wired. The channels not to be used must be connected to the analog ground.
- If there is no appropriate signal source available at voltage input, either connect a cell or connect the channel to the analog ground to check for 0V.

The board works with the Diagnosis Program but not with an application.

The Diagnosis Program is coded with API-TOOL functions. As long as the board operates with the Diagnosis Program, it is to operate with other applications as well. In such cases, review your program while paying attention to the following points:

- Check the return values of functions.
- Check the Driver No. and Board No.

The OS won't normally get started or detect the board.  
[Windows Vista, XP, Server 2003, 2000]

Turn off the power to your PC, then unplug the board. Restart the OS and delete the board settings of API-TOOL Configuration. Turn off the PC again, plug the board, and restart the OS. Let the OS detect the board and use API-TOOL Configuration to register board settings.

## If your problem cannot be resolved

Contact your retailer.





## 3. External Connection

This chapter describes the interface connectors on the product and the external I/O circuits. Check the information available here when connecting an external device.

### How to connect the connectors

#### Connector shape

To connect an external device to this product, plug the cable from the device into the interface connector (CN1) shown below.

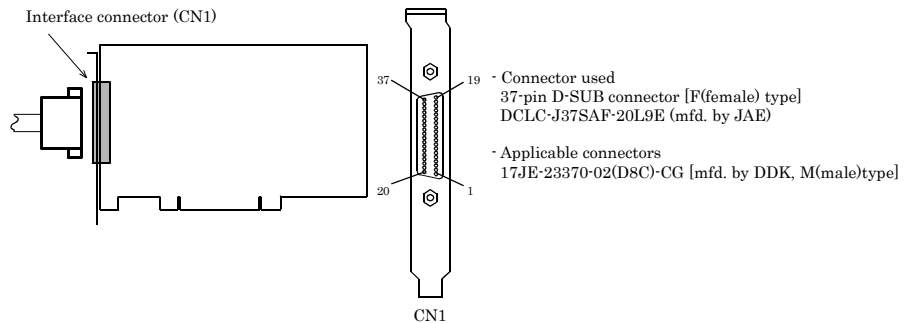

\* Please refer to chapter 1 for more information on the supported cable and accessories.

**Figure 3.1. Interface Connector Shape**

## Connector Pin Assignment

Pin Assignments of Interface Connector (CN1)

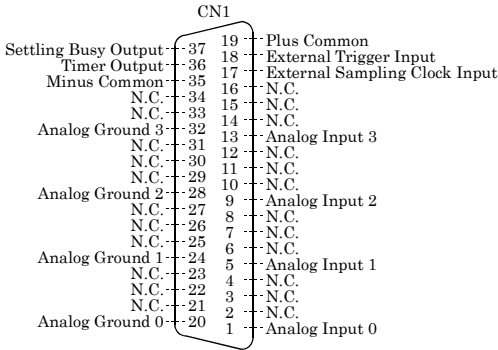

Analog Input 0 - Analog Input 3	Analog input signal. The numbers correspond to channel numbers.
Analog Ground 0 - Analog Ground 3	Analog grounds for identically numbered analog input signals.
External Trigger Input	External trigger input signal
External Sampling Clock Input	External sampling clock input signal
Timer Output	Programmable timer output signal
Sampling Busy Output	Output signal indicating that the board is performing AD conversion.
Plus Common	Connect the plus side of external power supply. Common for each “External Trigger Input”, “External Sampling Clock Input”, “Timer Out”, “Sampling Busy Out” channel.
Minus Common	Connect the minus side of external power supply. Common for each “Timer Out”, “Sampling Busy Output” channel.
N.C.	No connection to this pin.

**Figure 3.2. Pin Assignments of Interface Connector (CN1)**

# Connecting the Analog Input Signal

## Input Circuit of Analog Input Signal

Input equivalent circuit is as follows.

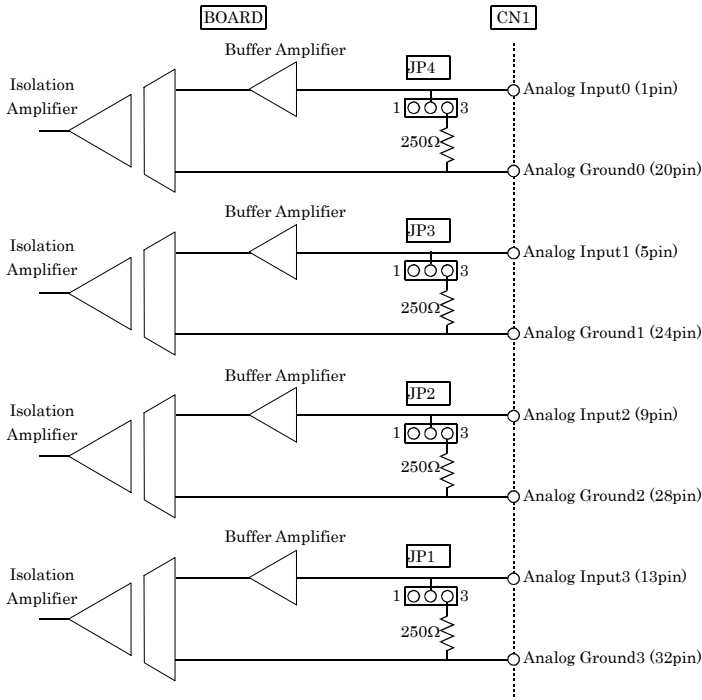

**Figure 3.3. Input equivalent circuit**

Analog signals are input to each channel via the isolation amplifier. This electrically isolates the channels from one another and this product's internal circuitry (PC) from the input pin.

The 250Ω resistor in the circuit is a precision resistor that converts current to voltage when current input has been set with jumpers.

## Connection Example of Voltage Signal Source

The following figure shows an example of optional flat cable (PCA37P) connection. Connect each input channel in CN1 and the corresponding analog ground in pairs to the signal source.

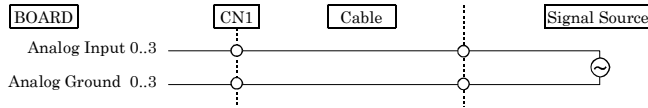

**Figure 3.4. Connecting the Voltage Signal Source (Flat cable)**

The following example connects a signal source to this product using a shielded cable such as a coaxial cable. Use shielded cable if the distance between the signal source and this product is long or if you want to provide better protection from noise. Connect each analog input channel in CN1 and the corresponding analog ground to the signal source, using the core of the shielded cable and its shield braid, respectively.

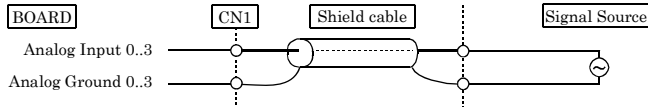

**Figure 3.5. Connecting the Voltage Signal Source (Shield cable)**

### ⚠ CAUTION

- An input voltage signal should not exceed the maximum input voltage (relate to the analog ground). If it exceeds the maximum voltage, this product may be damaged.
- Connect all the unused analog input channels to analog ground.
- As a long connection cable may fail to accurately input analog signals, the connection cable should be as short as possible.
- If the connection cable receive noise, analog may not be input properly. Route the connection cable as far apart from noise sources as possible.

## Connection Example of Current Signal Source

The following figure shows an example of optional flat cable (PCA37P) connection.

Connect each analog input channel in CN1 and the corresponding analog ground to the + and - sides of the current source, respectively.

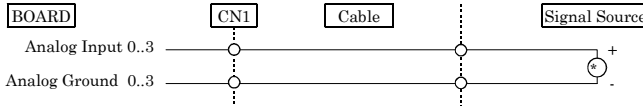

**Figure 3.6. Connecting the Current Signal Source (Flat cable)**

The following example connects a signal source to this product using a shielded cable such as a coaxial cable. Use shielded cable if the distance between the signal source and this product is long or if you want to provide better protection from noise. Connect each analog input channel in CN1 to the + side of the current source using the core of the shielded cable and the corresponding analog ground to the - side using the shield braid.

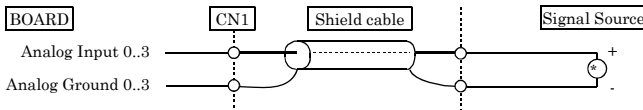

**Figure 3.7. Connecting the Current Signal Source (Shield cable)**



### CAUTION

- An input current signal should not exceed the maximum input current. If it exceeds the maximum current, this product may be damaged.
- Connect all the unused analog input channels to analog ground.
- As a long connection cable may fail to accurately input analog signals, the connection cable should be as short as possible.
- If the connection cable receive noise, analog may not be input properly. Route the connection cable as far apart from noise sources as possible.

# Connecting the Control Signal

## Connecting the Input Signal

To the “External Sampling Clock Input” and “External Trigger Input” pins, connect current driven devices such as a switch and a transistor output device. Input circuit is as follows. An external power supply is required to drive the input circuit. The power capacity required at this time is about 11 mA per input channel at 24 VDC (or about 5.5 mA at 12 VDC).

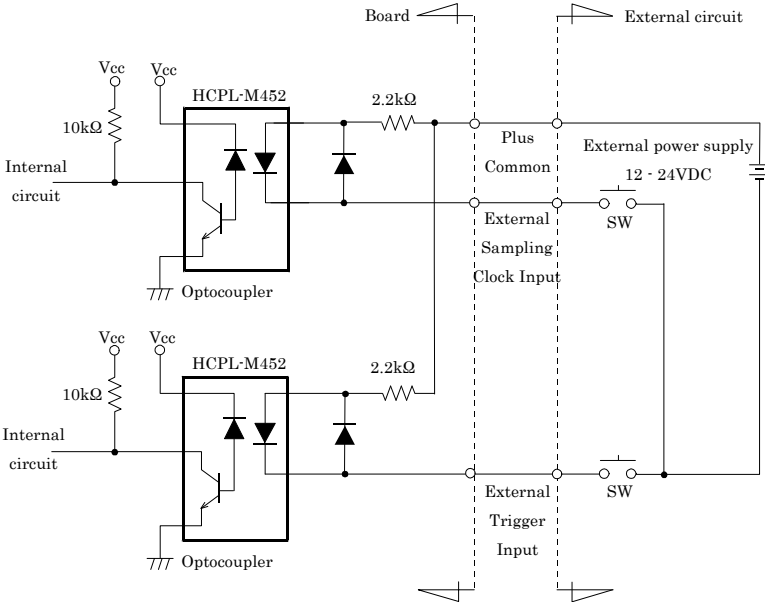
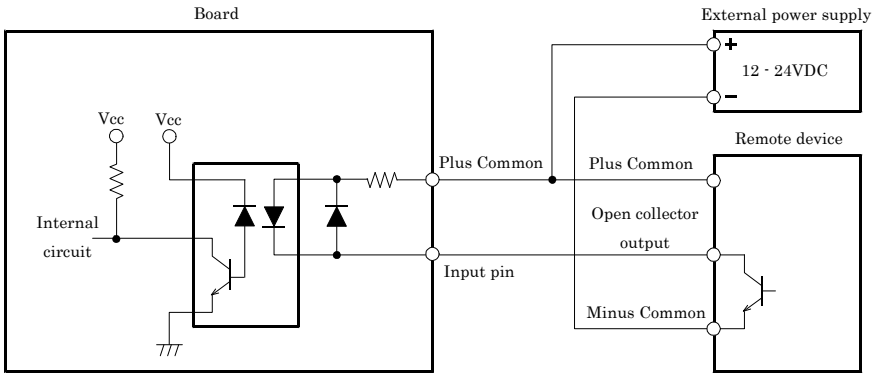
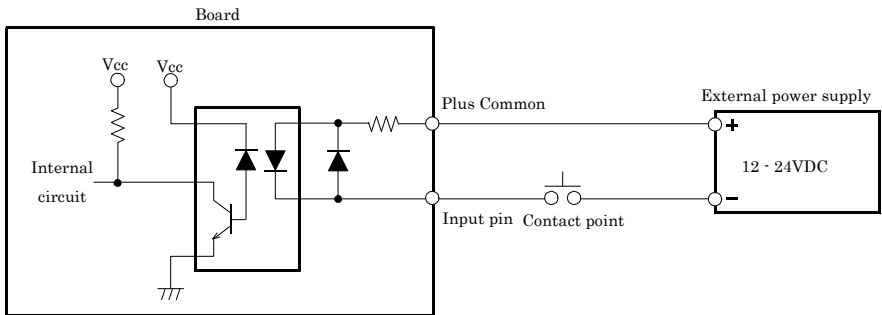

Figure 3.8. Input Circuit



**Figure 3.9. Connection Example to Open Collector Output (Current Sink Type)**



**Figure 3.10. Connection Example to Mechanical Contact**

In the above example, the input signal and data (internal logic) on the PC have the following relationships.

**Table 3.1. Relationships between input signal and data (internal logic) on the PC**

Internal logic	Contact point	Input pin voltage level
0	OFF	High
1	ON	Low

#### Reference

For the operation timings for control signal input, see "Timing of External Control Signals" in Chapter 6 "Hardware".



## Connecting the Output Signal

To the “Timer Output” and “Sampling Busy Output” pins, connect a relay controller or a current driven control device such as a LED. Output circuit is as follows.

An external power supply is required to drive the output circuit. Output current rating is 50 mA (Max.) per 1 point. This product’s output transistor is not associated with a surge voltage protection circuit. When this product is used to drive the inductive load to a relay or lamp, apply surge protection to the load side.

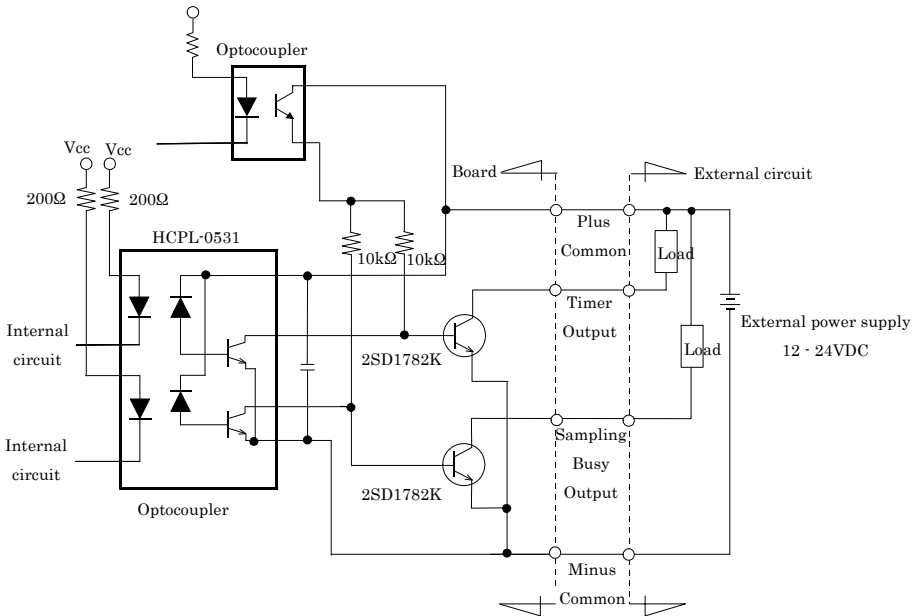
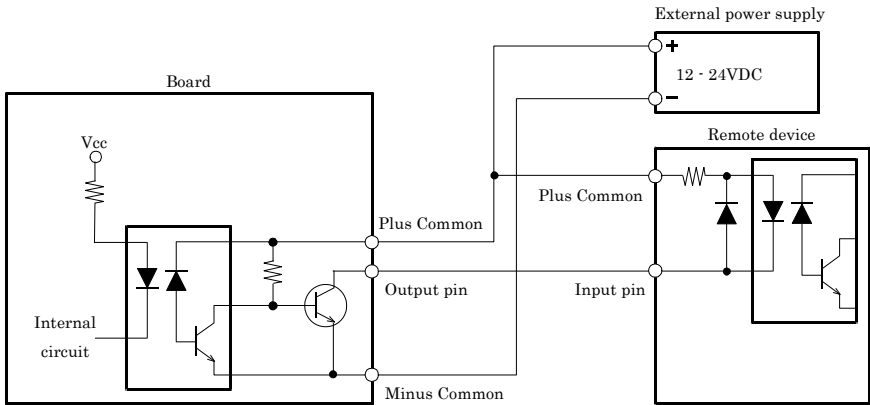

**Figure 3.11. Output Circuit**



### CAUTION

All of the output are turned off when the power is turned on.



**Figure 3.12. Connection Example to Current Sink Input**

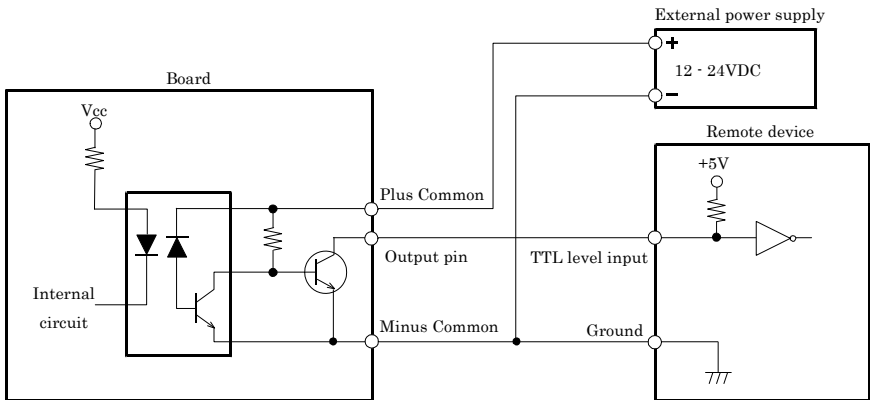
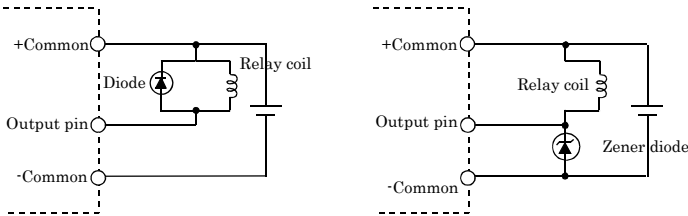

**Figure 3.13. Connection Example to TTL level Input (with Pull-up Resistor)**

# Surge Voltage Countermeasures

When connecting a load that generates surge voltages and inrush currents, such as an induction load (relay coil) or an incandescent light bulb, to the digital output, appropriate protection must be provided in order to prevent damage to the output stage or a malfunction due to noise. The rapid shutoff of a coil, such as a relay, generates a sudden high-voltage pulse. If this voltage exceeds the voltage tolerance level of the output transistor, it can cause the transistor to gradually deteriorate, or even completely damage the transistor. Therefore, when driving an induction load, such as a relay coil, you should always connect a surge-absorbing device. The following illustrates a surge voltage countermeasure that can be employed:

- Examples of use of relay coil



- Examples of use of lump

External power voltage < Zener diode voltage

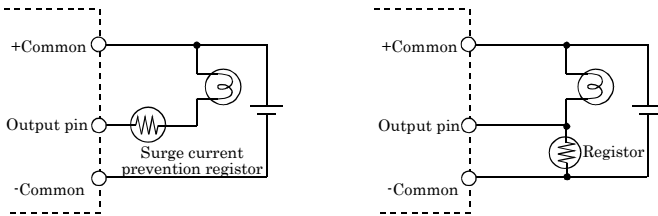

**Figure 3.14. Surge Voltage Countermeasure**

**⚠ CAUTION**

In order for a protection circuit to operate effectively, it must be connected within 50cm of a load and a contact point.

## 4. Functions

This chapter describes the different functions that can be implemented using the hardware and driver together. Unless stated otherwise, the driver is assumed to be API-AIO(WDM).

### Analog Input Function

This product converts analog signals to digital data according to the resolution and stores it in memory. You can set a variety of conditions for analog input, including the input channel, sampling period, and sampling start/stop conditions.

Analog input processes are classified as follows:

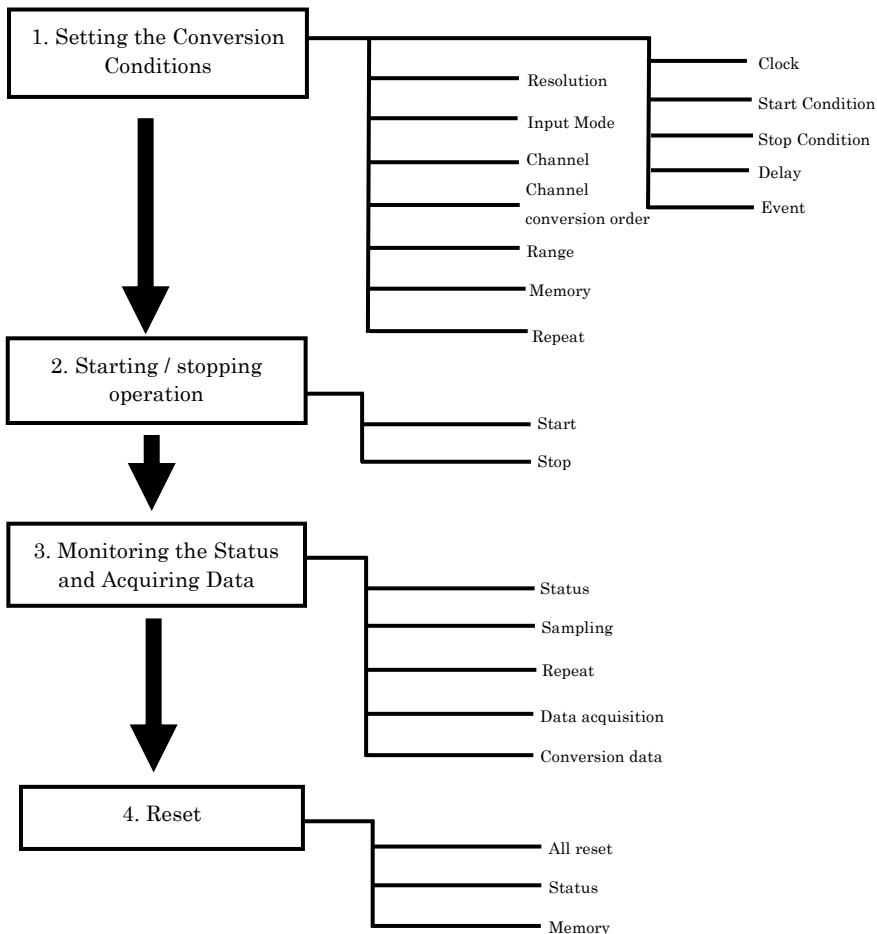

## 1. Setting the Conversion Conditions

First, set the conditions for executing analog input.

### Resolution

“Resolution” signifies the number of bits used by an analog input device to represent analog signals. The higher the resolution, the more finely the voltage range is segmented, allowing the device to convert analog values to digital equivalents more precisely.

A device with a resolution of 12bit divides the range width into 4096 segments.

When the device covers the range of 0 - 10V, the minimum unit of converted voltages is  $10 \div 4096 \approx 2.44\text{mV}$ .

If the device has a resolution of 16bit, it is  $10 \div 65536 \approx 0.153\text{mV}$  instead.

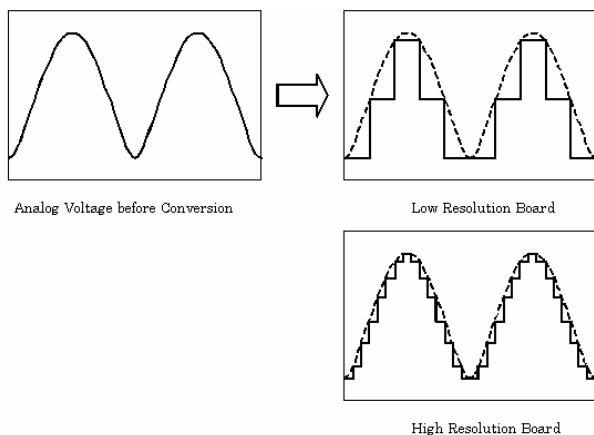

AI-1604CI2-PCI : The resolution is 16bit.

### Input Mode

Input mode of this product is single-ended input. There is no necessity for setting by software.

### Channel

“Channel” represents individual channel No. for analog input signal.

For channel No., see “How to connect the connectors” - “Connector Pin Assignment” in Chapter 3 “External Connection”.

For the channel selection, specify the channel No. or the number of channel which you want to convert A into D (channel consecutive from channel 0)

### Channel conversion order

Normally, when converting more than one channel during one sampling session, the channels are converted starting from channel 0, as shown below.

The channel conversion order for this product is fixed. It does not require any software setting.

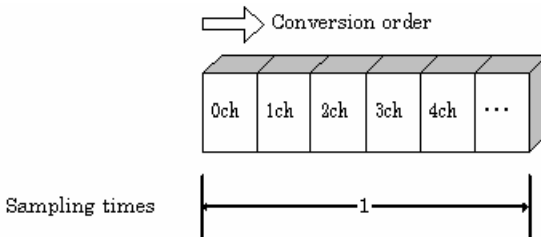

### Range

“Range” means the range of voltages at which analog input can be performed.

The input range can be selected by setting the upper and lower input signals.

AI-1604CI2-PCI : The range is specified by setting both the jumpers and software. Please refer to the “Chapter2 Setup - Setting the Hardware - Setting the Analog Input”.

### Memory

Device’s or driver’s input data storage memory is used to enable advanced analog input processing at high speed. For the memory, the FIFO or ring format can be selected by means of software.

AI-1604CI2-PCI : The product uses the memory for storing converted data on the driver.

#### - FIFO format

In the FIFO (First In First Out) format, input data items are read from memory in the same order in which they were written to the memory. Input data items are fed out of the memory sequentially, where the oldest one is always read from the memory. The status monitor and application notification functions are provided, which check and report the state in which the memory has stored a fixed amount of data or in which the memory has become full.

The FIFO memory is used to obtain all input data from analog input in a short or infinite period of time.

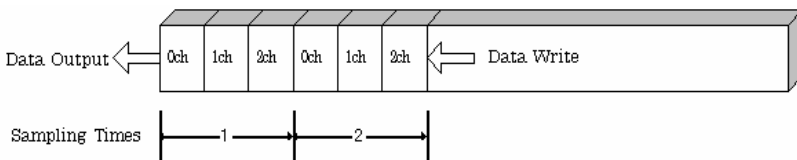

- Ring format

In the ring format, the memory contains storage areas arranged in a ring. Input data items are written to the memory sequentially. When it stores data exceeding the limit, it overwrites the area storing the previous item of input data. The status monitor and application notification functions are provided, which check and report the state in which data has been written to certain areas of memory.

The ring memory is used to obtain data where conversion has stopped due to some event, usually without obtaining data in the normal state.

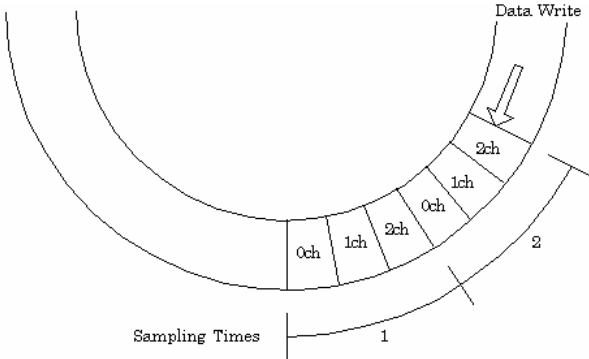

## Repeat

“Repeat” indicates the number of repetitions of sampling to be executed, from when the sampling start condition is satisfied until the end of sampling, including delayed sampling.

The number of repetitions is set by means of software, for which conversion is repeated. You can set an infinite number of repetitions, in which case the conversion is terminated by the software abort command.

Input data items are stored to the memory sequentially. The repetition state can be subject to status monitoring and application notification.

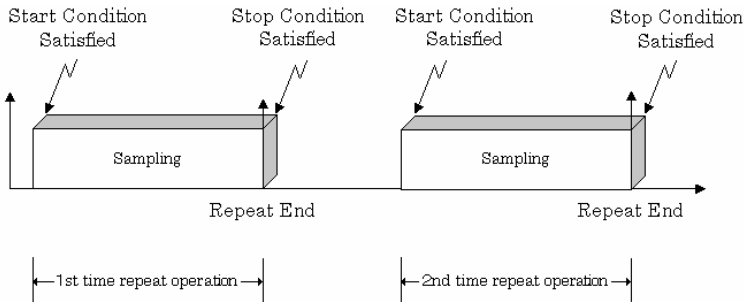

This product does not support the Repeat feature when the sampling start condition is "software".

## Clock

The sampling clock controls the sampling frequency. You can select both the internal sampling clock and the external sampling clock. The sampling clock is selected by means of software.

- Internal sampling clock  
The clock signal from the device clock generator is used.
- External sampling clock  
The edge of the digital signal input from an external device is used for the sampling clock.



Start Condition

The condition for controlling the start of sampling can be selected from among software, input data comparison and an external trigger. The conditions for controlling the start and stop of sampling are completely independent of each other; they can be set separately.

- Software  
This product starts sampling and storing input data to memory immediately after the operation start command is issued.
- Input data comparison  
When the operation start command is issued, this product compares the analog signal input through a specified channel to the value of the preset comparison level. If the analog signal satisfies the condition, this product starts storing input data.  
Level comparison conditions are set as two conditions: level and direction.

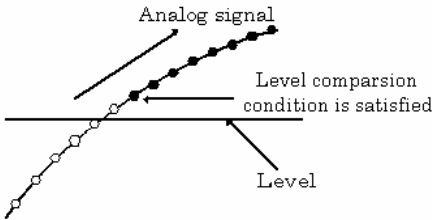

The above sketch shows that the level comparison condition is satisfied in the rising direction. The start condition is satisfied when the analog signal at the specified channel passes the comparison level in the rising direction. Input data items are stored to memory, starting with those at solid dots.

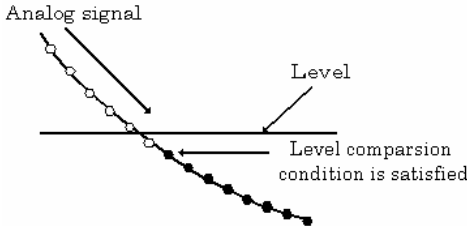

The above sketch shows that the level comparison condition is satisfied in the falling direction. The start condition is satisfied when the analog signal at the specified channel passes the comparison level in the falling direction. Input data items are stored to memory, starting with those at solid dots.

If you set the level comparison directions to both directions, the start condition is satisfied when the analog signal passes the level both in the rising and falling directions.

- External trigger  
This product starts waiting for an external control signal as soon as the operation start command is output.  
Sampling and data transfer to memory start when the external control signal (falling edge) is input.

### Stop Condition

The condition for controlling the stop of sampling can be selected from among the last sampling count, input data comparison, an external trigger, and software abort.

This product stops sampling whenever an error occurs irrespective of the stop condition setting.

- Last sampling count  
This product stops sampling after storing input data to memory for the specified number of times of sampling.
- Input data comparison  
Once this product has started sampling, it compares the analog signal input through a specified channel to the value of the preset comparison level. If the analog signal satisfies the condition, this product stops sampling.  
Level comparison conditions are set as two conditions: level and direction.

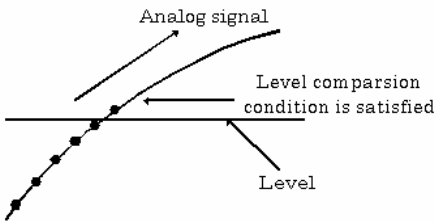

The above sketch shows that the level comparison condition is satisfied in the rising direction. The stop condition is satisfied when the analog signal at the specified channel passes the comparison level in the rising direction. Input data items are stored to memory, ending until those at solid dots.

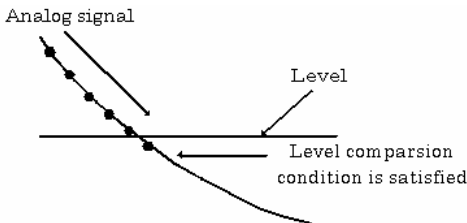

The above sketch shows that the level comparison condition is satisfied in the falling direction. The stop condition is satisfied when the analog signal at the specified channel passes the comparison level in the falling direction. Input data items are stored to memory, ending until those at solid dots

If you set the level comparison directions to both directions, the start condition is satisfied when the analog signal passes the level both in the rising and falling directions.

- External trigger  
This product starts waiting for an external control signal after the specified number of samples have been performed. Sampling stops when the external control signal (falling edge) is input.
- Software  
Sampling continues indefinitely in this mode. Sampling only stops in response to a software command or an error.

### Delay

Delayed sampling is performed after the sampling stop condition is satisfied.

When a sampling stop condition other than the software about command is satisfied, this product performs sampling for the specified number of times of delayed sampling to store input data to memory. If you set the number of times of delayed sampling to 0, this product stops sampling the moment the sampling stop condition is satisfied.

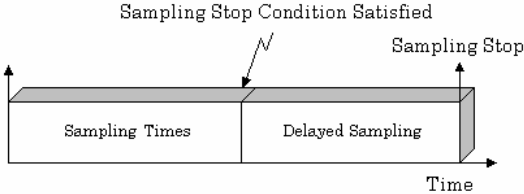

### Event

“Event” works as a function for reporting the occurrence of a certain product state to the application. The following events can be used in combination depending on the specifications and purpose of the application.

- “AD conversion start condition satisfied” event  
This event occurs when the AD conversion start condition is satisfied. The event is nullified when the conversion start condition is “software”.
- “Repeat end” event  
This even occurs whenever a repetition is completed.
- “End of device operation” event  
This event occurs when the entire operation including repetitions is completed.
- “Stored specified sampling times” event  
This event occurs when sampling has been performed for the number of times set by software.
- Overflow event  
This event occurs at an attempt to store input data with the memory full.
- Sampling clock error event  
This event occurs when conversion stops as an error occurs due to a sampling clock period that is too short.
- AD conversion error event  
This event occurs when conversion stops due to an AD conversion error.

## 2. Starting/Stopping Operation

Sampling is started by the software command.

Once started, sampling can be stopped by the software command at any timing.

### 3. Monitoring the Status and Acquiring Data

Software commands are used to monitor the operation status of the device and to acquire input data from memory. Status monitoring and data acquisition can be performed even during sampling.

#### Status

The current state of the device can be checked by obtaining the device status.

The following types of device status are available:

- Device operating  
The “device operating” status remains ON, after the execution of the sampling start command until this product completes conversion, aborts operation due to an error, or stops sampling in response to the command.
- Waiting for start trigger  
This status remains ON, after this product starts sampling until the start trigger is input, if the conversion start condition is an external trigger or level comparison. The status is set to OFF when the input trigger is input to start conversion.  
The status is set to ON whenever this product enters the conversion start wait status even when repeated operation has been set.
- Specified sampling data stored  
This status is set to ON when input data stored in memory has reached the amount corresponding to the preset number of times of sampling.  
If the memory format is FIFO, the status is set to OFF when the amount of input data in the memory falls below the value corresponding to the preset number of times of sampling as data is acquired. Once the status is set to ON when the memory format is ring, it remains ON until it is reset.
- Overflow  
An overflow error occurs when an attempt is made to store input data to memory while it has been full of input data.  
When the memory format is FIFO, this product stops conversion.  
When the memory format is ring, this product continues conversion while overwriting existing data with new one.
- Sampling clock error  
This error occurs when the sampling clock period is too short.
- AD conversion error  
If the “device operating” status remains ON (without terminating conversion) for an extended period of time, the driver regards that state as an operation error and sets this status to ON. This error stops sampling.

#### Sampling

The number of sampled items of input data stored in memory can be obtained by the software command.

#### Repeat

The current repeat count can be obtained by the software command.

Data acquisition

The conversion data stored in memory can be retrieved using a software command.

The figure below shows the correspondence between the sampling count and the conversion channel for the conversion data stored in memory.

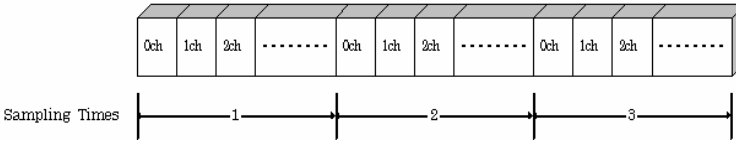

Input data is acquired differently depending on the memory format used.

- Data acquisition in FIFO format

When FIFO memory is used, the oldest data is always read first.

The following sketch shows an image of data acquisition in FIFO format.

When data is acquired from the memory, the free memory space increases by that data size. When data is acquired next, the oldest one of the existing data items is taken from the memory in the same way.

The FIFO memory deletes data once that data is acquired.

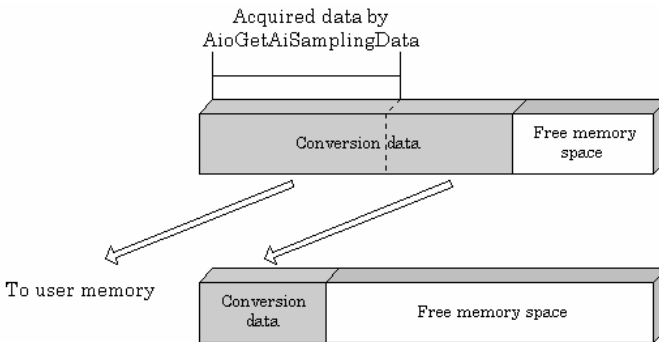

- Data acquisition in ring format  
When ring memory is used, data is read always with respect to the current input data write position.  
The following sketch shows an image of data acquisition in ring format.  
The sampling count obtained is always the number of times of sampling for up to the latest data (shaded portion below).  
The larger the number of samples taken, the older the data item acquired first.  
As the ring memory retains data even after that data is acquired, you can fetch the same data any number of times.

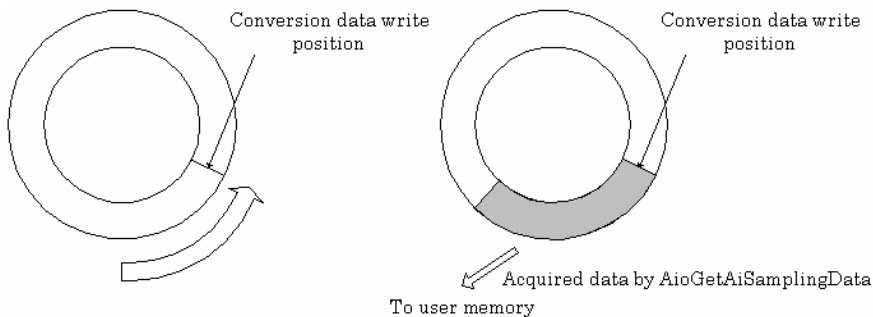

## Conversion data

The following equation represents the relationship between input data and voltage.

$$\text{Voltage} = \text{Input data} \times (\text{Max. range value} - \text{Min. range value}) \div \text{Resolution} + \text{Min. range value}$$

The value of resolution for the 12bit device is 4096

< $\pm 10\text{V}$  range>

The table below shows the relationship between A-D conversion data and voltage.

Voltage	Conversion data (12bit)	Voltage	Conversion data (16bit)
+9.995V	4095	+9.99970V	65535
:	:	:	:
0.005V	2049	0.00030V	32769
0V	2048	0V	32768
-0.005V	2047	-0.00030V	32767
:	:	:	:
-10.000V	0	-10.000V	0

Ex.: When input data 3072 is input at a resolution of 12bit in the  $\pm 10\text{V}$  range

$$\begin{aligned} \text{Voltage} &= 3072 \times (10 - (-10)) \div 4096 + (-10) \\ &= 5.0 \end{aligned}$$

## &lt;0 - 10V range&gt;

The table below shows the relationship between A-D conversion data and voltage.

Voltage	A-D conversion data (12bit)	Voltage	Conversion data (16bit)
+9.998V	4095	9.99985V	65535
:	:	:	:
5.002V	2049	5.00015V	32769
5V	2048	5V	32768
4.998V	2047	4.99985V	32767
:	:	:	:
-0V	0	0V	0

Ex.: When A-D conversion data 3072 is input at a resolution of 12bit in the 0 - 10V range

$$\begin{aligned} \text{Voltage} &= 3072 \times (10 - 0) \div 4096 + 0 \\ &= 7.5 \end{aligned}$$

## 4. Reset

Various states can be reset by executing the following reset commands:

### All reset

This command resets the entire device, thereby initializing the device.

### Status

This command resets the sampling clock error status and AD conversion error status.

### Memory

This command resets the following memory related states.

- Resets the sampling count to 0.
- Resets the status for the specified sampling count to OFF.
- Resets the buffer overflow status to OFF.
- Resets the repeat count to 0.





## 5. About Software

### CD-ROM Directory Structure

```

\
|— Autorun.exe           Installer Main Window
|  |— Readmej.html       Version information on each driver (Japanese)
|  |— Readmeu.html       Version information on each driver (English)
|  .
|  |— APIPAC             Each installer
|  |  |— AIO
|  |  |  |— DISK1
|  |  |  |— DISK2
|  |  |  |— .....
|  |  |  |— DISKN
|  |  |— AioWdm
|  |  |— CNT
|  |  |— DIO
|  |  |— .....
|  .
|  |— HELP              HELP file
|  |  |— Aio
|  |  |— Cnt
|  |  |— .....
|  .
|  |— INF              Each INF file for OS
|  |  |— WDM
|  |  |— WinVista
|  |  |— Win2000
|  |  |— Win95
|  .
|  |— linux            Linux driver file
|  |  |— cnt
|  |  |— dio
|  |  |— .....
|  .
|  |— Readme           Readme file for each driver
|  .
|  |— Release          Driver file on each API-TOOL
|  |  |— API_NT        (For creation of a user-specific install program)
|  |  |— API_W95
|  .
|  |— UsersGuide       Hardware User's Guide(PDF files)

```

## About Software for Windows

The bundled CD-ROM “Driver library API-PAC(W32)” contains the functions that provide the following features:

- Analog input or output through arbitrary channels
- Analog input at arbitrary intervals using the internal or external sampling clock
- Simultaneous monitoring of the termination of analog input sampling, buffer memory usage, and interrupt events such as occurrences of errors
- Driver option check using a demo driver even without the board installed

For details, refer to the help file. The help file provides various items of information such as “Function Reference”, “Sample Programs” and “Q&A”. Use them for program development and troubleshooting.

# When using the API-AIO(WDM)

## Accessing the Help File

- (1) Click on the [Start] button on the Windows taskbar.
- (2) From the Start Menu, select “Programs” – “CONTEC API-PAC(W32)” – “AIO(WDM)” – “API-AIO(WDM) HELP” to display help information.

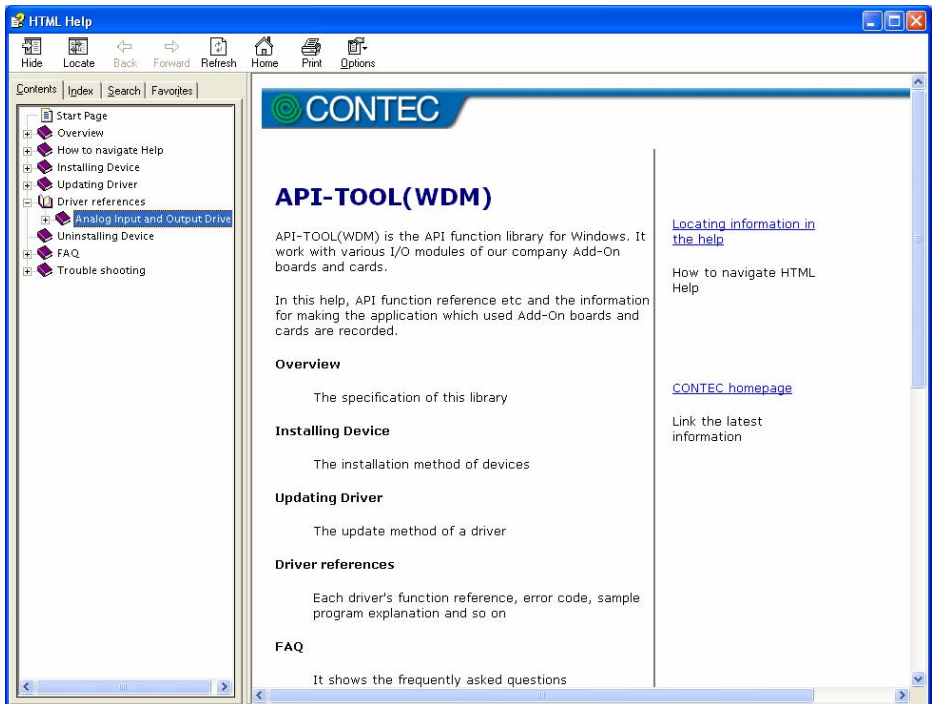

## Using Sample Programs

Sample programs are provided for each of the basic operations. You can use these to check the operation of the board and as a reference when writing your own programs.

To use the sample programs, specify the device name in the property page for the program.

The sample programs are stored in (Program Files)\CONTEC\API-PAC(W32)\AIOWDM\Samples.

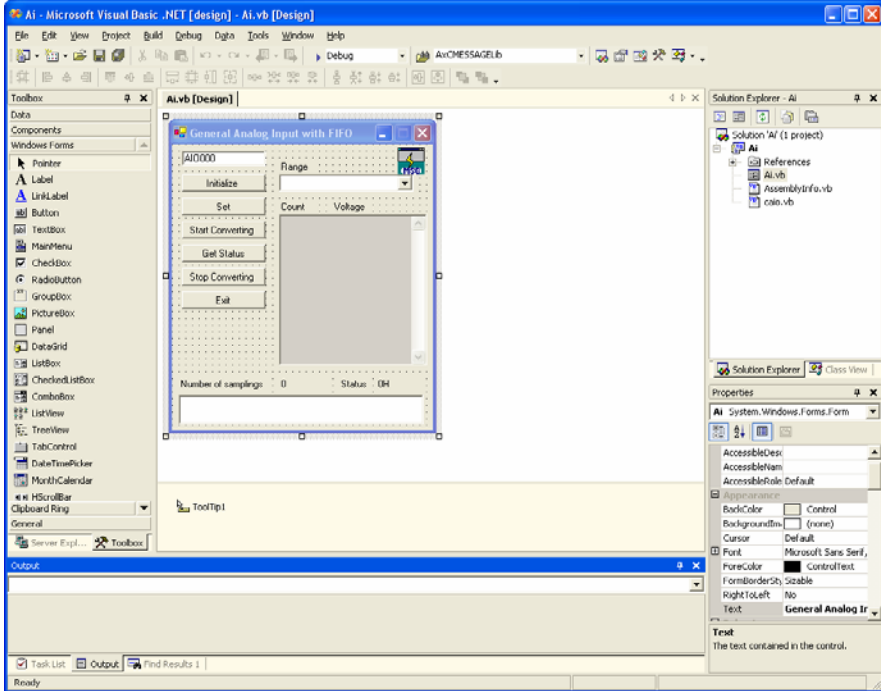

### Running a Sample Program

- (1) Click on the [Start] button on the Windows taskbar.
- (2) From the Start Menu, select “Programs” – “CONTEC API-PAC(W32)” – “AIOWDM” – “SAMPLE...”.
- (3) A sample program is invoked.

---

## Sample Programs - Examples

### Analog input

- SingleAi                    Perform single analog input from specified channel
- MultiAi                    Perform single analog input from multiple channels
- Ai                            Perform standard analog input using a FIFO buffer
- AiPoll                      Perform standard analog input by polling
- AiEx                        Perform analog input for multiple channels using a FIFO buffer
- AiLong                     Perform long-duration analog input using a FIFO buffer
- AiExt                      Perform analog input using an external clock
- AiTrg                      Perform analog input using an external trigger to start and stop operation
- AiLevel1                  Use a level trigger to start analog input
- AiLevel2                  Use a level trigger to stop analog input
- Ai2                         Perform standard analog input using more than one board

### Analog output

- SingleAo                    Perform single analog output from specified channel
- MultiAo                    Perform single analog output from multiple channels
- Ao                            Perform standard analog output using a FIFO buffer
- AoPoll                     Perform standard analog output by polling
- AoEx                        Perform analog output for multiple channels using a FIFO buffer
- AoLong                     Perform long-duration analog output using a FIFO buffer
- AoExt                      Perform analog output using an external clock
- AoRing                     Perform continuous analog output using a ring buffer
- AoTrg                      Perform analog output using an external trigger to start and stop operation
- Ao2                         Perform standard analog output using more than one board

### Digital input/output

- DioBit                      Perform digital I/O using bit values
- DioByte                    Perform digital I/O using port values

\* Sample programs executable vary with the functions of boards in use.

## Usage of Utility Program

### Program for Measurement of Function Execution Speed

The execution time of some main functions can be measured in a function execution speed measurement program. To use a function execution speed measurement program, click the [execution time measurement] button in the diagnostic program.

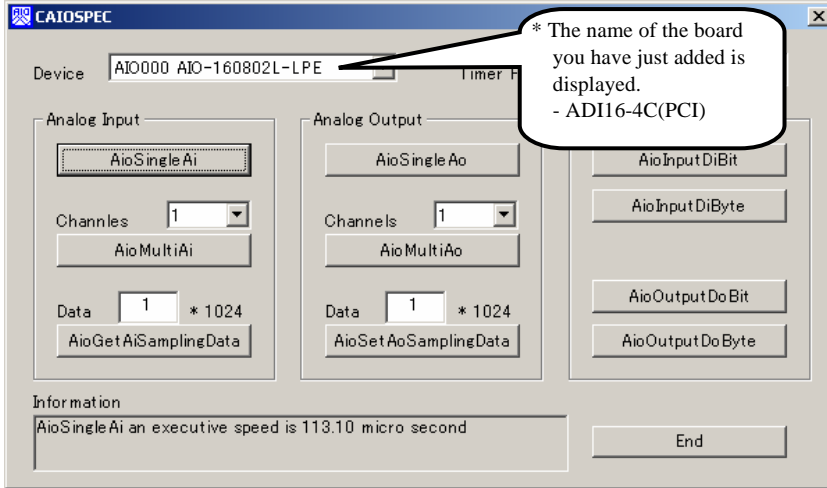

### ⚠ CAUTION

Note that the displayed board name is "ADI16-4C(PCI)" even though you have installed this board. There is no problem in operation even if the board name is displayed as "ADI16-4C(PCI)".

### Procedure

- (1) Chose the measure device from device list.
- (2) Click the button written with the function name to measure the execution speed of the function. Please choose from a list the number of channels used for conversion in function AioMultiAi and AioMultiAo. Input the transmission data size in function AioGetAiSamplingData and AioSetAoSamplingData. The transmission data is set by unit of kByte.
- (3) End the application with an [end] button.

## Analog Input Measurement Tool

It is an analog input measurement utility to carry out infinity sample in the FIFO memory. Once the conversion data of memory accumulates to a certain quantity, the event occurs and data of the memory is acquired. Data in the FIFO memory can be confirmed visually.

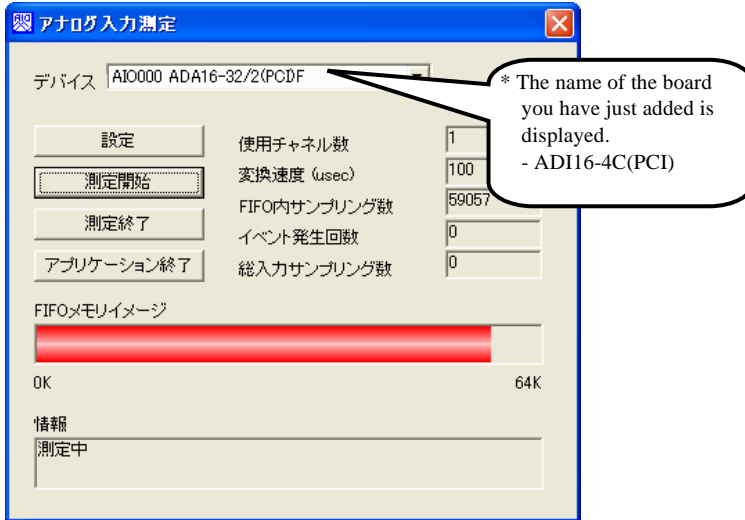

### ⚠ CAUTION

Note that the displayed board name is "ADI16-4C(PCI)" even though you have installed this board. There is no problem in operation even if the board name is displayed as "ADI16-4C(PCI)".

The number of channels used, the internal/external clock, the conversion speed, and the sampling frequency at which an event generates can be set. Since the notification of a sampling clock error event is sent, please make use of it for the conversion spec measurement under various conversion conditions.

### ⚠ CAUTION

**This program is made with Visual Basic. Therefore, it is not possible to execute it as it is in the environment in which Visual Basic is not installed. The program can be used by executing the following setup below the folder that installs the API-AIO(WDM).**

**AIOWDM\Utility\AiSpec\setup.exe**



## Procedure

(1) Chose the device name of the device to be used from the upper left combo box, and click the setting button.

(2) The conversion conditions are set on the screen of the analog input setting.

Once an input is done at the sampling frequency specified as data taking-in sampling, an event occurs and data will be acquired. Click the OK button to finish setting the conditions, and returns to former screen.

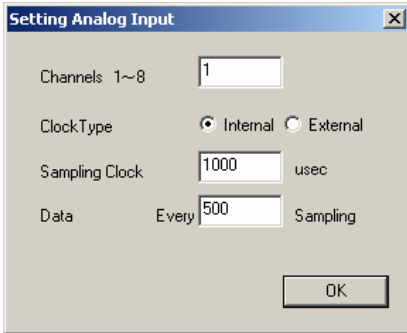

(3) Start the measurement with measurement start button. The various states during the conversion are displayed.

The number of the samplings in FIFO is :

It is conversion data taken in the memory. This can be visually checked in a "memory image".

Event generation sampling frequency :

When the number of input sampling in FIFO reaches this frequency, the event generates.

Total input sampling frequency :

It is the total number of samplings for application in the memory.

Measurement may stop by the following errors.

Sampling clock error :

It means that the conversion speed is too fast and the driver processing is not in time when converting at the internal clock.

The cycle of the clock is too fast when converting it at the external clock. Moreover, the cause by noise etc. is also concerned.

Buffer overflow :

The memory overflows since the conversion speed is too fast compared with the one at which data is inputted.

(4) Click the "stop" button, and measurement stops.

# When using the API-AIO(98/PC)

## Accessing the Help File

- (1) Click on the [Start] button on the Windows taskbar.
- (2) From the Start Menu, select “Programs” – “CONTEC API-PAC(W32)” – “Aio” – “API-AIO HELP” to display help information.

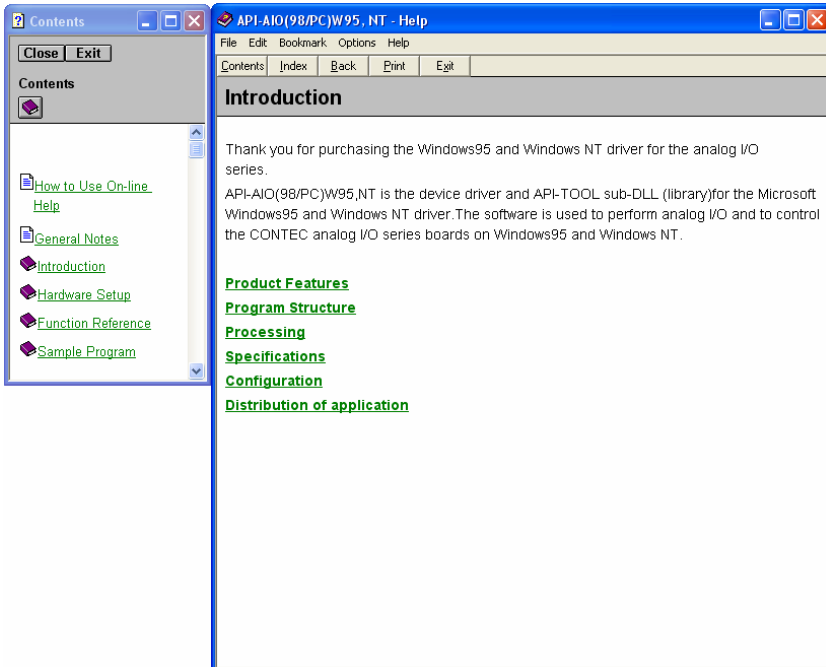

## Using Sample Programs

Sample programs have been prepared for specific basic applications.

To use each sample program, enter its device name set by API-TOOL Configuration.

Use these sample programs as references for program development and operation check.

The sample programs are stored in \Program Files\CONTEC\API-PAC(W32)\Aio\Samples.

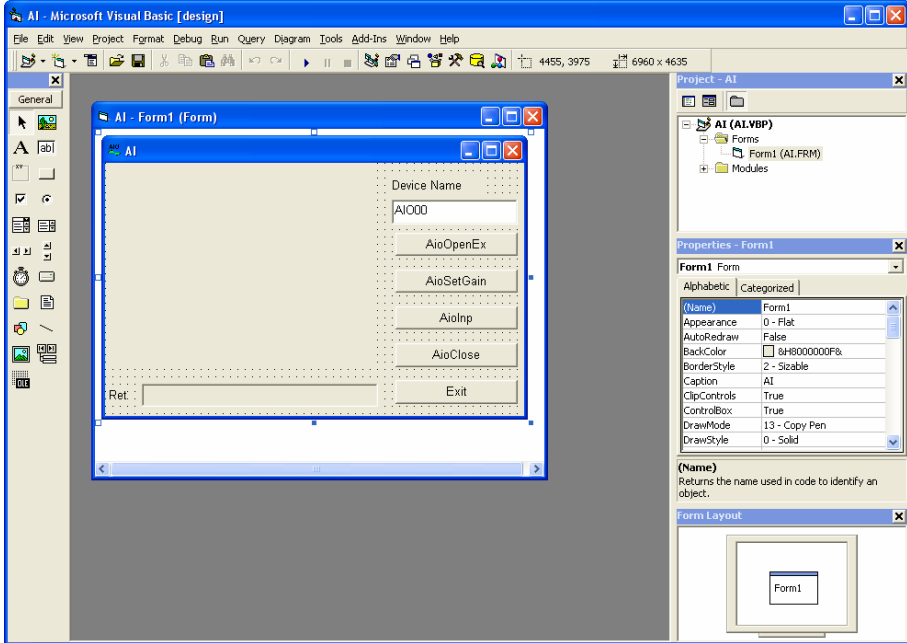

### Running a Sample Program

- (1) Click on the [Start] button on the Windows taskbar.
- (2) From the Start Menu, select “Programs” – “CONTEC API-PAC(W32)” – “Aio” – “SAMPLE...”.
- (3) A sample program is invoked.

## Sample Programs - Examples

### Analog input

- AI : Uses AioInp to convert an analog signal only once and display the data.
- AIBack : Uses AioInpBack to perform memory-less board analog input.
- AIMemory : Uses AioInpBdMem to perform continuous conversion and AioReadBuf to acquire data from board memory (an example of using an external clock).
- AIInt : Infinite sampling example that uses AioInpBdMem for half/full interrupts and AioReadBuf to acquire data at interrupt events.
- AITimer : Infinite sampling example that uses AioInpBdMem to perform continuous conversion and AioReadBuf to acquire data at system timer events.
- AISync : Sample that uses AioInpBdMem and AioDO to perform simultaneous sampling of two memory-mounted boards.
- AioInp : Sample console application that uses AioOpenEx and AioInp.

### Analog output

- AO : Uses AioOut to perform analog output once.
- AOBBack : Uses AioOutBack to perform analog output at fixed intervals.
- AioOut : Sample console application that uses AioOpenEx and AioOut.

### Digital input and output

- DIO : Uses AioDO and AioDI to perform digital input/output.

### Counter

- Timer : Sample program using a timer. It uses the counter function to measure the lapse of time.
- Counter : Sample program using a counter. It uses the counter function to count external pulses.

The following sample program in Visual Basic is available.

- ANALOG : Versatile sample program using AioInp, AioInpBack, AioInpBdMem, AioOut, AioOutBack, AioDO, and AioDI

\* Sample programs executable vary with the functions of boards in use.

## Using the Utility Program

### Operation Check Tool

This program is a comprehensive operation check tool that can use all the features of the AioOpen, AioClose, AioSetRangeAioInp, AioInpBack, AioInpBdMem, AioOut, AioOutBack, AioDo, and AioDi functions.

Invoke the tool by selecting the Start Menu – “CONTEC API-PAC(W32)” – “AIO” – “SAMPLE Analog”.

#### [Main screen]

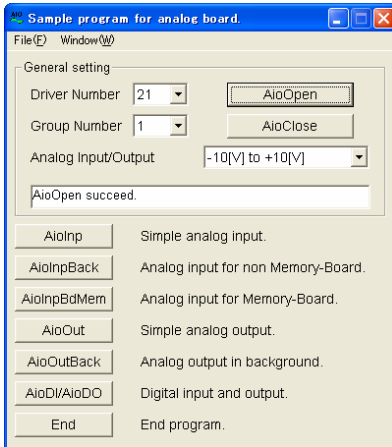

AioInp : Simple analog input

AioInpBack : Analog input for non Memory-Board

AioInpBdMem: Analog input for Memory-Board

AioOut : Simple analog output

AioOutBack : Analog output in background

AioDi/AioDO : Digital input and output

#### [Analog input]

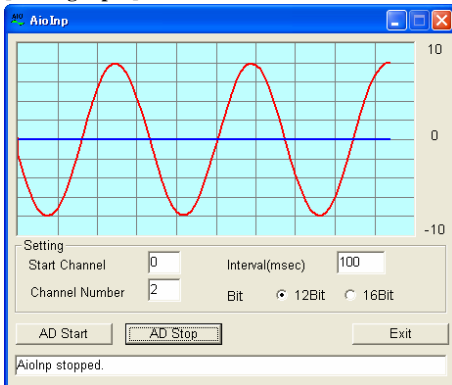

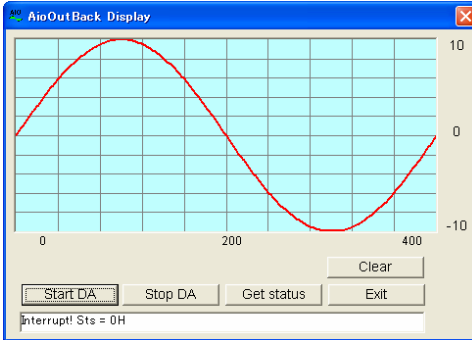
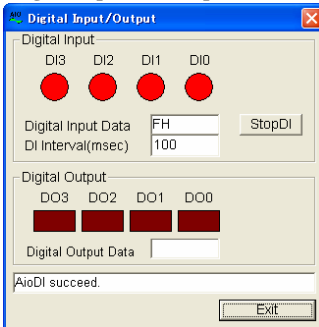
**[Analog output]****[Digital input and output]**

# Uninstalling the Driver Libraries

The method used to uninstall API-PAC(W32) differs depending on which OS you are using. Follow the procedure given below.

## Uninstall procedure for Windows Vista

< Uninstalling the device driver >

1. Run Device Manager. From [My Computer] - [Control Panel], select [System] and then select the [Device Manager] tab.  
(You can also open Device Manager by right clicking on My Computer and selecting Properties.)
2. All of the hardware that uses the API-TOOL(WDM) driver is registered under the CONTEC Devices tree.  
Open the device tree, select the hardware to uninstall, and then right-click the hardware.  
From the popup menu, select [Uninstall].

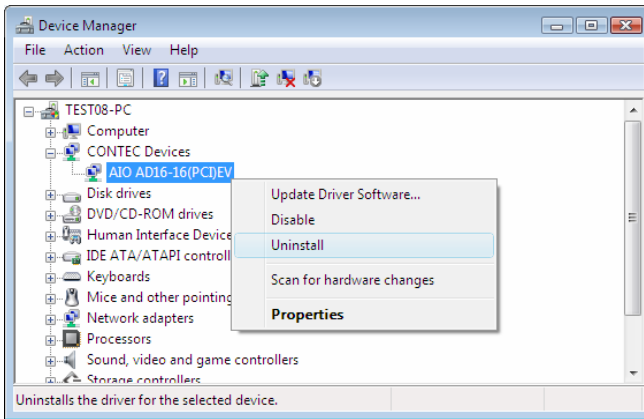

3. A dialog box opens asking you to confirm whether to uninstall. Select the [Delete the driver software for this device] checkbox, and then click [OK].



< Uninstall the development environment >

Use [My Computer] - [Control Panel] - [Add and Remove Programs] to uninstall the development environment.

Select [CONTEC API-\*\*\* (WDM) VerX.XX (development environment)] and then click [Uninstall].

\* "\*\*\*" contains the driver category name (AIO, CNT, DIO, SMC, etc.).

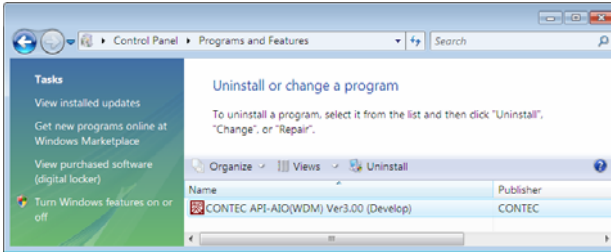

Uninstall procedure for Windows XP and Windows 2003 Server

< Uninstall the device driver >

Use [My Computer] - [Control Panel] - [Add and Remove Programs] to uninstall the device driver. Select [Windows driver package - CONTEC (\*\*\*)] and then click [Change/Remove].

\* "\*\*\*" contains the driver category name (caio, ccnt, cdio, csmc, etc.).

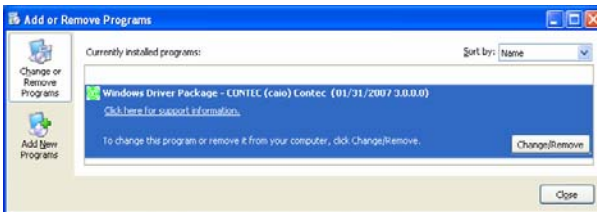

< Uninstall the development environment >

Use [My Computer] - [Control Panel] - [Add and Remove Programs] to uninstall the development environment.

Select [CONTEC API-\*\*\* (WDM) VerX.XX (development environment)] and then click [Change/Remove].

\* "\*\*\*" contains the driver category name (AIO, CNT, DIO, SMC, etc.).

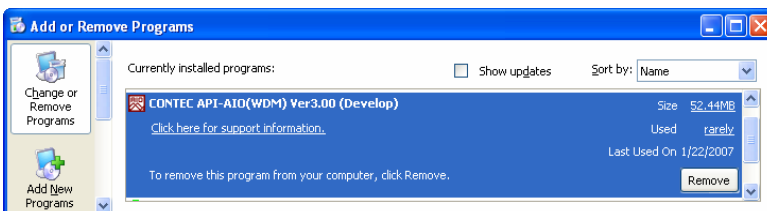



### Uninstall procedure for Windows Me

#### < Uninstalling the device driver >

Use [My Computer] - [Control Panel] - [Add or Remove Programs] to uninstall the device driver. Select [CONTEC API-\*\*\*(WDM) driver] and then click [Change/Remove].

\* "\*\*\*" contains the driver category name (caio, cnt, cdio, csmc, etc.).

#### < Uninstall the development environment >

Use [My Computer] - [Control Panel] - [Add or Remove Programs] to uninstall the development environment.

Select [CONTEC API-\*\*\*(WDM) VerX.XX (development environment)] and then click [Change/Remove].

\* "\*\*\*" contains the driver category name (AIO, CNT, DIO, SMC, etc.).

### Uninstall procedure for Windows 98, 98SecondEdition

#### < Uninstalling the device driver >

Use [My Computer] - [Control Panel] - [Add or Remove Programs] to uninstall the device driver. Select [CONTEC API-\*\*\*(WDM) driver] and then click [Change/Remove].

\* "\*\*\*" contains the driver category name (caio, cnt, cdio, csmc, etc.).

#### < Uninstall the development environment >

Use [My Computer] - [Control Panel] - [Add or Remove Programs] to uninstall the development environment.

Select [CONTEC API-\*\*\*(WDM) VerX.XX (development environment)] and then click [Change/Remove].

\* "\*\*\*" contains the driver category name (AIO, CNT, DIO, SMC, etc.).

## About Software for Linux

The Linux version of analog I/O function driver, API-AIO(LNX), provides functions that execute the following features:

- The analog input/output of a specified channel can be done.
- It is possible to operate as a set parameter to the analog input/output board is preserved by the default value, and the setting of the parameter doesn't exist.

For details, refer to the help file. The help file provides various items of information such as "Function Reference", "Sample Programs", and "FAQs". Use them for program development and troubleshooting.

## Driver Software Install Procedure

The Linux version for digital I/O driver, API-AIO(LNX), is supplied as a compressed file /linux/aio/caioXXX.tgz on the bundled API-PAC(W32)CD-ROM. (Note: XXX represents the driver version.)

Mount the CD-ROM as shown below, copy the file to an arbitrary directory, and decompress the file to install the driver.

For details on using the driver, refer to readme.txt and the help file in HTML format extracted by installation.

To install the driver, log in as a superuser.

Decompression and setup procedure

```
# cd
# mount /dev/cdrom /mnt/cdrom           Mount the CD-ROM.
# cp /mnt/cdrom/linux/aio/caioXXX.tgz ./ Copy the compressed file.
# tar xvfz caioXXX.tgz                 Decompress the compressed file.
.....
# cd contec/caio
# make
                                     Compile the file.
.....
# make install                         Install.
.....
# cd config
# ./config                             Set up the board to be used.
..... Set as follows.....
# ./contec_aio_start.sh                Start the driver.
# cd
```

## Accessing the Help File

- (1) Invoke a web browser in your X-Window environment.
- (2) In the browser, open diohelp.htm in the contec/caio/help directory.

## Using Sample Programs

Sample programs have been prepared for specific basic applications. Sample programs for each language are contained in the contec/caio/samples directory. For compiling them, refer to the manual for the desired language.

## Uninstalling the driver

To uninstall the driver, use the uninstall shell script contained in the contec/caio directory. For details, check the contents of the script.

## 6. About Hardware

This chapter provides hardware specifications and hardware-related supplementary information.

### **For detailed technical information**

For further detailed technical information (“Technical Reference” including the information such as an I/O map, configuration register, etc.), visit the Contec's web site (<http://www.contec.com/support/>) to call for it.

# Hardware specification

**Table 6.1. Common specification**

Item	Specification
Analog Input	
Isolated specification	Channel-isolation
Input Type	Single-Ended Input
Number of input channels	4channel
Input range	Bipolar $\pm 10V$ , $\pm 5$ , Unipolar $0 - +10V$ , $0 - +5V$ 4 - 20mA (Set the input range using both jumpers and software setting.)
Absolute max. input voltage	$\pm 11V$ (Voltage input based on the analog ground of each channel)
Absolute max. input current	30mA (Current input)
Input impedance	1M $\Omega$ or more (Voltage input, power ON) 1k $\Omega$ or more (Voltage input, power OFF)
Resolution	16bit
Non-Linearity error *1	$\pm 32LSB$ ( $\pm 10V$ ) $\pm 64LSB$ ( $\pm 5V$ , $0 - +10V$ ) $\pm 64LSB$ ( $0 - +5V$ ) $\pm 80LSB$ (4 - 20mA)
Conversion speed	20 $\mu$ sec [50KSPS] /ch (Max.)
Buffer memory	None
Conversion start condition	Software / external trigger
Conversion stop condition	Count stop / external trigger / software
Sampling clock	Internal sampling clock : 20,000 - 1,073,741,824,000nsec (Can be set in 250 nanoseconds) External sampling clock : Optocoupler isolated input (corresponding to current sink output)
Passband (-3dB)	1kHz
Programmable timer	
Setup frequency	500 - 1,073,741,824,000nsec (Can be set in 250nsec units)
Status	Count up, count up and over run
Timer output signal	Optocoupler isolated open collector output (current sink type)
External trigger input	
External trigger input signal	Optocoupler isolated input (corresponding to current sink output)
Status	Trigger input, trigger input over run
I/O address	32 ports boundary
Interrupt level	1 level use
Isolation voltage	500Vrms
Power consumption (Max.)	+5VDC 1100mA
Operating condition	0 - 50°C, 10 - 90%RH (No condensation)
Bus specification	PCI (32bit, 33MHz, Universal key shapes supported *2)
Dimension (mm)	176.41(L) x 106.68(H)
Used connector	37-pin D-SUB connector [F(female) type] DCLC-J37SAF-20L9E [mfd.by JAE] or equivalence to it
Weight	200g

\*1 A linearity error approximately 0.5% of full-range may occur when operated at 0°C or 50°C ambient temperature.

\*2 This product requires +5V power supply from the expansion slot (it does not work in a +3.3V environment).

## Board dimension

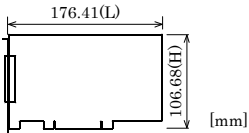

The standard outside dimension (L) is the distance from the end of the board to the outer surface of the slot cover.

## Block Diagram

Figure 6.1 is a circuit block diagram of this product.

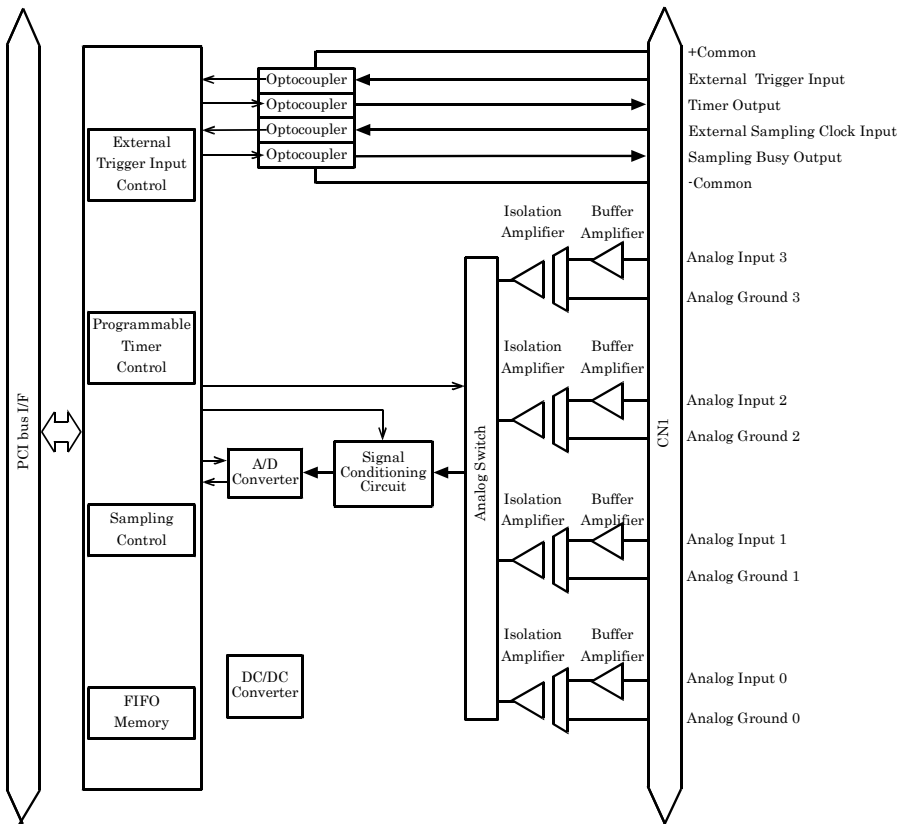
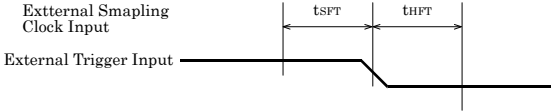

Figure 6.1. Block Diagram

## Timing for Control Signal

### Timing for External Sampling Clock and External Trigger Inputs

Figures 6.2 and Table 6.2 shows the timing for external sampling clock and external trigger input signal.



**Figure 6.2. Timing for External Sampling Clock and External Trigger Inputs**

**Table 6.2. Description**

	Symbol	Min.
Input circuit OFF→Set up time of ON	$t_{SFT}$	2.5 $\mu$ sec
Input circuit OFF→Hold time of ON	$t_{HFT}$	2.5 $\mu$ sec

### Timing for External Trigger Input and Input Status

Figures 6.3 and Table 6.3 shows the timing for external trigger input and input status.

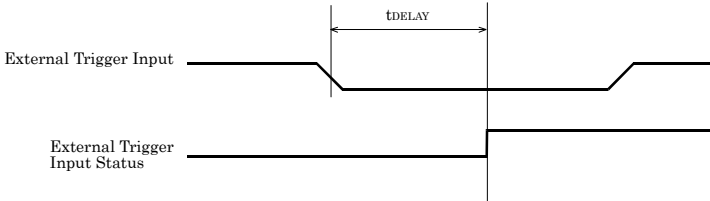

**Figure 6.3. Timing for External Trigger Input and Input Status**

**Table 6.3. Description**

	Symbol	Max.
Delay time	$t_{DELAY}$	5 $\mu$ sec

## Timing for External Sampling Clock Input and AD Conversion in Progress Output Signal

Figures 6.4 and Table 6.4 shows the timing for external sampling clock input and AD conversion in progress output signal.

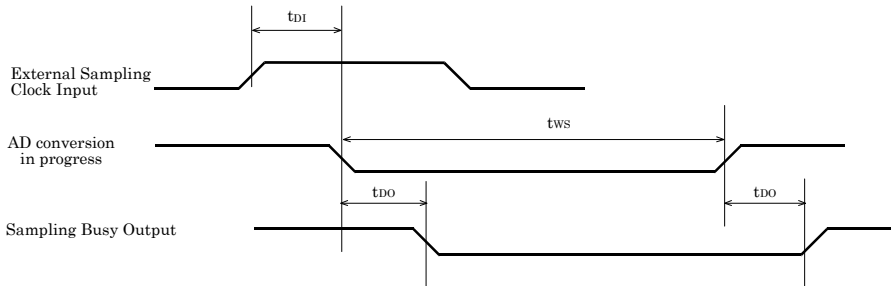

**Figure 6.4. Timing for External Sampling Clock Input and AD Conversion in Progress Output Signal**

**Table 6.4. Description**

	Symbol	Min.	Max.
Input delay time	$t_{DI}$	5 $\mu$ sec	---
Sampling operating time	$t_{WS}$	---	20 $\mu$ sec x channel No.
Output delay time	$t_{DO}$	2.5 $\mu$ sec	---

## Timing for Timer Output

Figures 6.5 and Table 6.5 shows the timing for timer output.

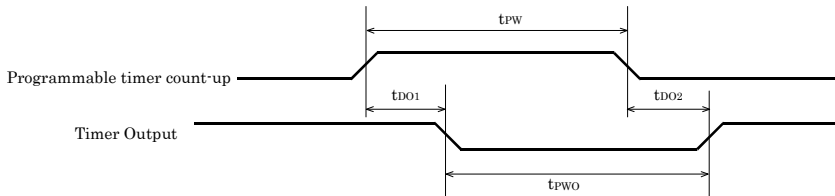

**Figure 6.5. Timing for Timer Output**

**Table 6.5. Description**

	Symbol	Min.	Average	Reference value
Occurring pulse width at the time of counting up	$t_{PW}$	---	2.5 $\mu$ sec	---
Output delay time 1	$t_{DO1}$	2.5 $\mu$ sec	---	---
Output delay time 2	$t_{DO2}$	2.5 $\mu$ sec	---	---
Output pulse width	$t_{PW0}$	---	---	3 $\mu$ sec

\* External power supply : 24V, Loading : 25°C when connecting 510 $\Omega$



## About Calibration

This product is calibrated before shipment.

Contact your retailer if this product does not provide its prescribed performance.

## Difference from ADI16-4C(PCI)-N, ADI16-4C(PCI)

This product is a successor of the previous model ADI16-4C(PCI)-N, ADI16-4C(PCI). So you can use the same operating procedures as ADI16-4C(PCI)-N, ADI16-4C(PCI).

The differences on the specification are as follows :

	AI-1604CI2-PCI	ADI16-4C(PCI)	ADI16-4C(PCI)-N
Non-Linearity error *1	±32LSB(±10V) ±64LSB(±5V, 0 · +10V) ±64LSB(0 · +5V) ±80LSB(4 · 20mA)	±32LSB(±10V) ±64LSB(±5V, 0 · +10V) ±128LSB(0 · +5V) ±160LSB(4 · 20mA)	±64LSB(±10V) ±128LSB(±5V, 0 · +10V) ±256LSB(0 · +5V) ±320LSB(4 · 20mA)
Displayed board name to be attached	ADI16-4C(PCI) *2	ADI16-4C(PCI)	ADI16-4C(PCI) *2
Environmental support	Product for RoHS instruction	Lead decrease product	
Passband (-3dB)	1kHz	3kHz	3kHz

\*1: The non-linearity error means an error of approximately 0.5% occurs over the maximum range at 0°C and 50°C ambient temperature.

\*2: Note that the displayed product name is "ADI16-4C(PCI)" even though you have installed this product. There is no problem in operation even if this product name is displayed as "ADI16-4C(PCI)".

# AI-1604CI2-PCI

## User's Guide

---

CONTEC CO., LTD.

June 2009 Edition

3-9-31, Himesato, Nishiyodogawa-ku, Osaka 555-0025, Japan

Japanese <http://www.contec.co.jp/>

English <http://www.contec.com/>

Chinese <http://www.contec.com.cn/>

No part of this document may be copied or reproduced in any form by any means without prior written consent of CONTEC CO., LTD. [06182009]

---

[08012007]

Management No. A-51-464

[06182009\_rev2]

Parts No. LYHP682