



Lite-Management Industrial Ethernet Switches

Quick Install Guide

Version 1.0

Introduction

SUNIX ESW-2xxx series are cost-effective 5-port/6-port/8-port redundant ring switches which adopt the newest structure to support ultra fast redundant ring function within 10mS (in 250 units). Its excellent performance protects your mission-critical applications from any network interruptions or temporary malfunctions. Additionally, it can automatically switch to other ports in 10mS when the master link fails. Therefore, ESW-2xxx series are the best cost-effective option for redundant Ethernet network.

Features

- Innovated ELite-Ring Supported: Recovery time is less than 10mS (250 units)
- Supports 10/100 Base-T(X) and 100 Base-FX
- Supports Device communication redundant mode : switch to other four ports in 10mS automatically
- Easy-to-configure: Web / Windows utility
- Windows utility (Sunix Componder) network management

Package List

Model Name	Accessory
ESW-2050	② X 1, ③ X 3, ⑤ X 1, ⑥ X 1, ⑦ X 1, ⑧ X 5
ESW-2060	① X 1, ② X 1, ③ X 6, ④ X 1, ⑥ X 1, ⑦ X 1, ⑧ X 6
ESW-2080	① X 1, ② X 1, ③ X 6, ④ X 1, ⑥ X 1, ⑦ X 1, ⑧ X 8
ESW-2042MM	① X 1, ② X 1, ③ X 6, ④ X 1, ⑥ X 1, ⑦ X 1, ⑧ X 4
ESW-2042SS	① X 1, ② X 1, ③ X 6, ④ X 1, ⑥ X 1, ⑦ X 1, ⑧ X 4

Accessory

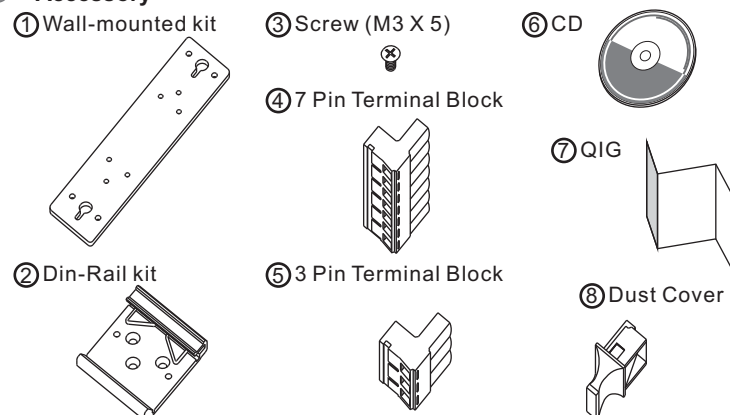

6-port/8-port products

■ DIN-Rail Install Step

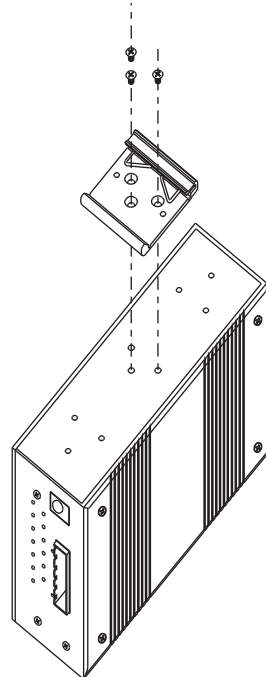

■ Wall-mounted Install Step

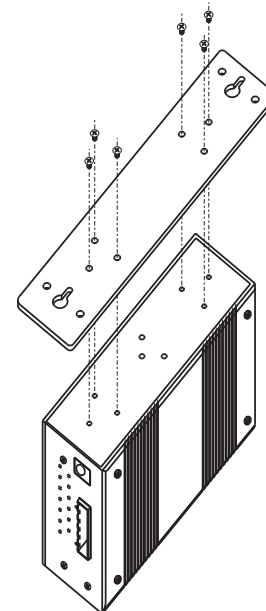

ESW-2050

■ Din-Rail Install Step

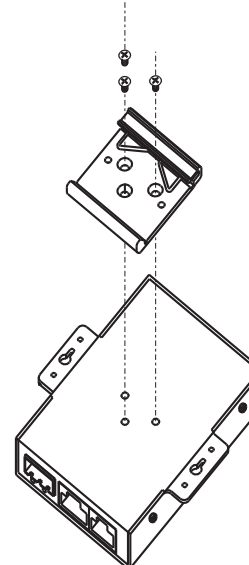

Model Specification

ESW-2050	5-port 10/100-T(X) Lite-Managed Ethernet Switch
ESW-2060	6-port 10/100-T(X) Lite-Managed Ethernet Switch
ESW-2080	8-port 10/100-T(X) Lite-Managed Ethernet Switch
ESW-2042MM	4-port 10/100-T(X) + 2-port Multi-Mode 100FX Lite-Managed Ethernet Switch
ESW-2042SS	4-port 10/100-T(X) + 2-port Single-Mode 100FX Lite-Managed Ethernet Switch

Power inputs & grounding



DC Powered Switch: Power is supplied through an external DC power source. Check the technical specification section for information about the DC power input voltage. Since the switch does not include a power switch, plugging its power adapter into a power outlet will immediately power it on.

ESW-2050 Front Hardware Guide

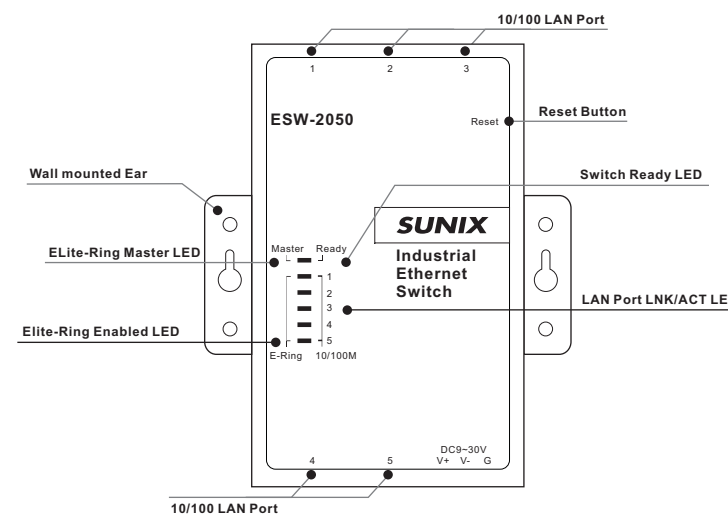



Lite-Management Industrial Ethernet Switches

● ESW-2060 Front Hardware Guide

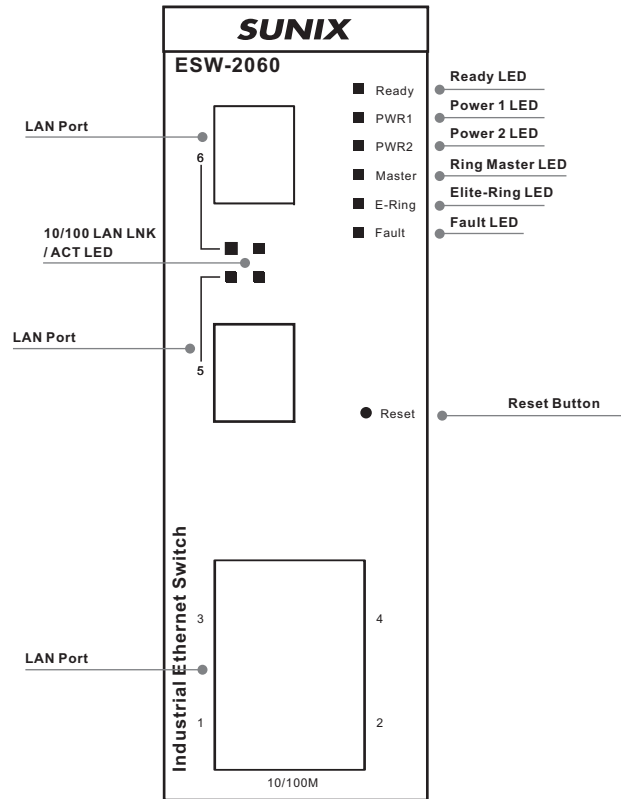

● 6 port/8 port Product

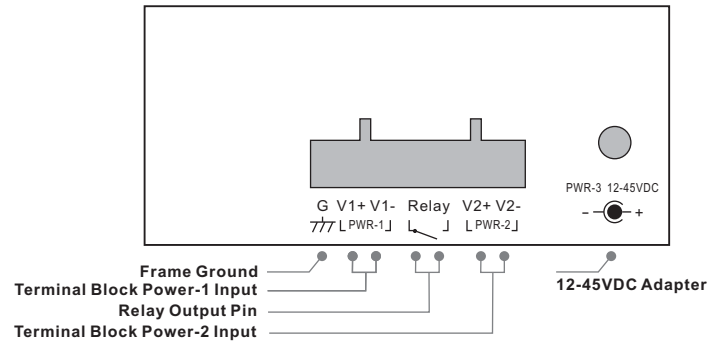

● ESW-2080 Front Hardware Guide

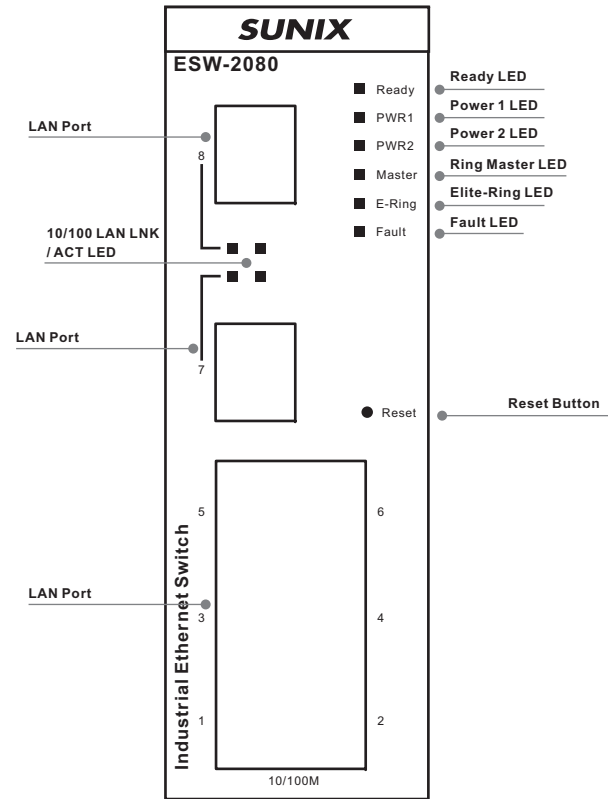

● ESW-2050 Power and LAN Connection Guide

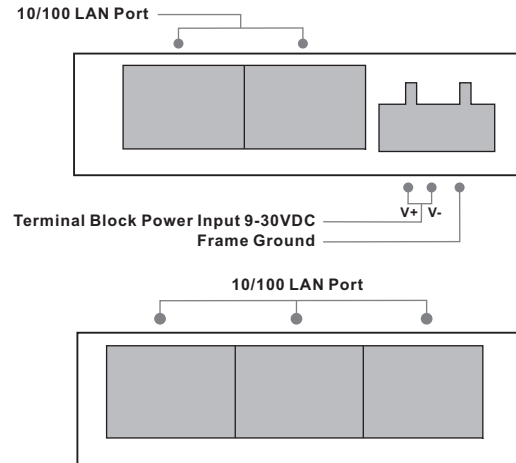

● ESW-2042MM / SS Front Hardware Guide

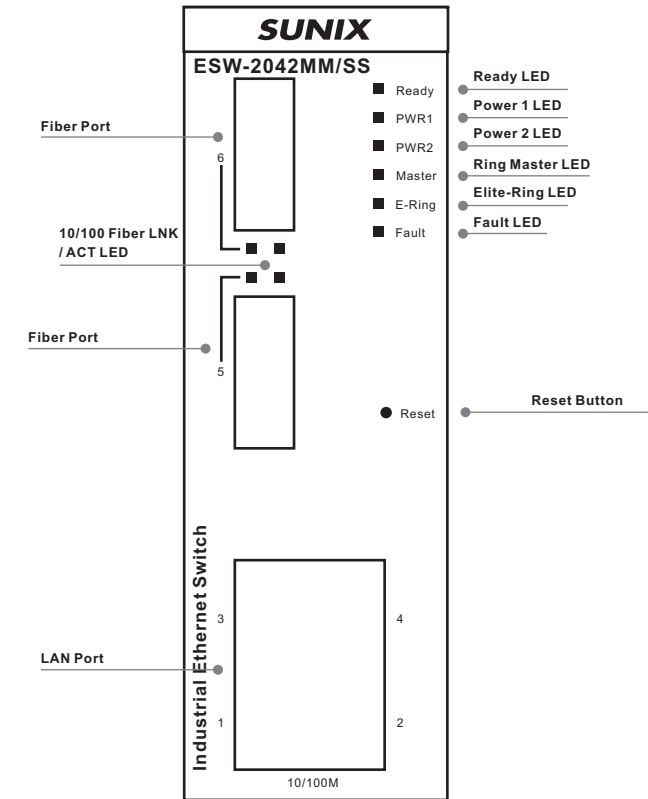

Copyright© by SUNIX Co, LTD.
All rights reserved.



TEL: +886-2-8913-1987
FAX: +886-2-8913-1986

Website: www.sunix.com.tw
E-mail: info@sunix.com.tw