



IMG-111 Series
Industrial M2M Gateway
User Manual

Version 2.0

July, 2014

www.oring-networking.com

COPYRIGHT NOTICE

Copyright © 2014 ORing Industrial Networking Corp.

All rights reserved.

No part of this publication may be reproduced in any form without the prior written consent of ORing Industrial Networking Corp.

TRADEMARKS

ORing is a registered trademark of ORing Industrial Networking Corp.

All other trademarks belong to their respective owners.

REGULATORY COMPLIANCE STATEMENT

Product(s) associated with this publication complies/comply with all applicable regulations.

Please refer to the Technical Specifications section for more details.

WARRANTY

ORing warrants that all ORing products are free from defects in material and workmanship for a specified warranty period from the invoice date (5 years for most products). ORing will repair or replace products found by ORing to be defective within this warranty period, with shipment expenses apportioned by ORing and the distributor. This warranty does not cover product modifications or repairs done by persons other than ORing-approved personnel, and this warranty does not apply to ORing products that are misused, abused, improperly installed, or damaged by accidents.

Please refer to the Technical Specifications section for the actual warranty period(s) of the product(s) associated with this publication.

DISCLAIMER

Information in this publication is intended to be accurate. ORing shall not be responsible for its use or infringements on third-parties as a result of its use. There may occasionally be unintentional errors on this publication. ORing reserves the right to revise the contents of this publication without notice.

CONTACT INFORMATION

ORing Industrial Networking Corp.

3F., No.542-2, Zhongzheng Rd., Xindian Dist., New Taipei City 23148, Taiwan (R.O.C.)

Tel: +886-2-2218-1066 // Fax: +886-2-2218-1014

Website: www.oring-networking.com

Technical Support

E-mail: support@oring-networking.com

Sales Contact

E-mail: sales@oring-networking.com (Headquarters)

sales@oring-networking.com.cn (China)

Tables of Contents

Getting Started	1
1.1 About the IMG-111 Series	1
1.2 Software Features	1
1.3 Hardware Features	1
Hardware Overview	2
2.1 Front Panel	2
2.2 Front Panel LED	3
Hardware Installation	4
3.1 DIN-Rail Installation	4
3.2 Wall Mounting	4
3.3 SIM Card Installation	5
Cables and Antenna	6
4.1 Ethernet Cables	6
4.2 Wireless Antenna	7
Management	8
5.1 Network Connection	8
5.2 Configuration	9
5.2.1 Basic Setting	9
WAN	9
LAN	10
DHCP	11
IP Allocation	12
5.2.2 Serial Setting	12
Remote management	12
Serial Configuration	13
Port Configuration	14
Service Mode	15
TCP Server Mode	16
TCP Client Mode	17
UDP Client Mode	18
5.2.3 Advanced Settings	18
NAT Setting	18
Security Setting	22
VPN Setting	23
Routing Protocol	29
Miscellaneous	32
5.2.4 System Tools	33

Date & Time	33
System Event	34
Login Setting	34
M2M Gateway Restart	35
Firmware Upgrade	36
Save/Restore Configurations	36
Remote Management	37
Miscellaneous (Ping).....	38
5.2.5 System Status.....	38
System Info	38
System Log.....	38
Traffic Statistics	39
5.3 DS-tool.....	39
5.3.1 General settings	39
5.3.2 Security	40
5.3.3 Network Setting.....	41
5.3.4 Upgrade Firmware.....	41
5.3.5 Reboot Device	41
5.3.6 Serial Settings.....	42
5.3.7 Service Mode.....	43
Virtual COM Mode	43
TCP Server Mode	45
TCP Client Mode	46
UDP Mode.....	48
Technical Specifications	49

Getting Started

1.1 About the IMG-111 Series

The IMG-111 series M2M Gateway is designed to operate in industrial environment, allowing devices to communicate with the Internet rapidly and efficiently over the LAN. The series consists of the IMG-111 and IMG-111-2G models to meet customers' different needs. The series comes with a RS-232 interface which enables users to access RS-232 data via 3.5G/2G connections. With built-in WAN connections, the series can be mounted in harsh environment easily to provide Internet access anytime and anywhere. The device also provides VPN capability to create encrypted virtual tunnels through the Internet, ensuring remote or mobile users safe connections to office networks.



1.2 Software Features

- 2G GSM/GPRS or 3.5G HSUDPA modem included
- Supports Open VPN, PPTP VPN
- Update DNS hostname: DDNS
- Versatile modes & event alarm by e-mail.
- Event warning by Syslog, Email, SNMP Trap, Relay output
- Redundant multiple host devices:
- 5 host devices: Virtual COM, TCP Server, TCP Client mode; UDP
- 4 IP Ranges: UDP

1.3 Hardware Features

- 1 x 10/100Base-T(X) Ethernet ports for LAN connection
- 1 x RS-232 Interface
- 1 x SIM card slot
- Power Inputs: 12~48 VDC
- Casing: IP-30
- Din-Rail and panel mounting enabled.
- Operating Temperature: -10 to 60°C
- Storage Temperature: -40 to 85°C
- Operating Humidity: 5% to 95%, non-condensing

Hardware Overview

2.1 Front Panel

The device provides the following ports on the front panel.

Port	Description
Ethernet port	1 x 10/100Base-T(X) copper ports
RS-232 port	1 x RS-232 Serial port
Reset button	Press the button for 3- 5 seconds to reset the device.
SIM card slot	1 x SIM card slot
Antenna connector	1 x antenna connector

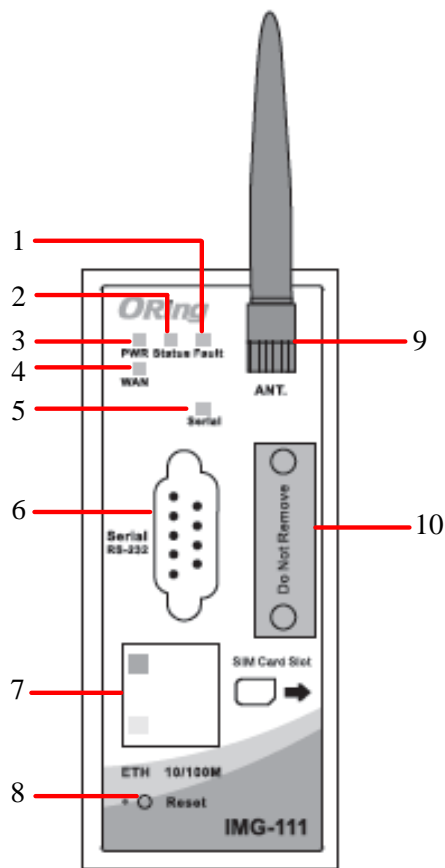

1. Fault LED. .
2. Status LED
3. Power LED
4. WAN LED
5. Serial transmission LED
6. RS-232 Serial port
7. 10/100Base-T(X) RJ45 fast Ethernet port

8. Reset button
9. GSM/DCS/UMT antenna for internal modem
10. SIM card slot

2.2 Front Panel LED

LED	Color	Status	Description
PWR	Green	On	Power On.
Status	Green	On	Device is ready
		Blinking	Booting up
Fault	Amber	On	WAN connection fails (enable event through web)
WAN	Green	On	Modem is ready
		Blinking	Checking modem status
ETH	Amber	On	Port speed at 10Mbps
	Green	On	Port speed at 100Mbps

Hardware Installation

3.1 DIN-Rail Installation

The device comes with a DIN-Rail kit in the package. The DIN-Rail kit allows you to fasten the device to a DIN-Rail.

Installing the device on the DIN-rail is easy. First, screw the Din-rail kit onto the back of the device, right in the middle of the back panel. Then slide the device onto a DIN-rail from the Din-rail kit and make sure the device clicks into the rail firmly.

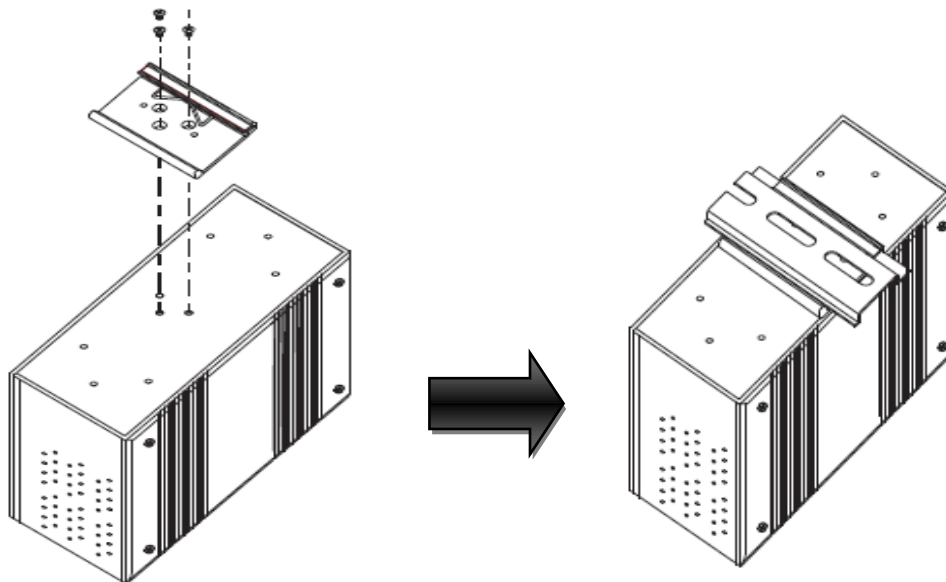

3.2 Wall Mounting

Besides Din-rail, the device can be fixed to the wall via a wall mount panel, which can be found in the package.

Follow the steps below to install the device to a rack.

Step 1: Install the L-shape mounting kits provided in the package to the left and right of the device.

Step 2: With front brackets orientated in front of the rack, mount the device in the rack with four rack-mounting screws.

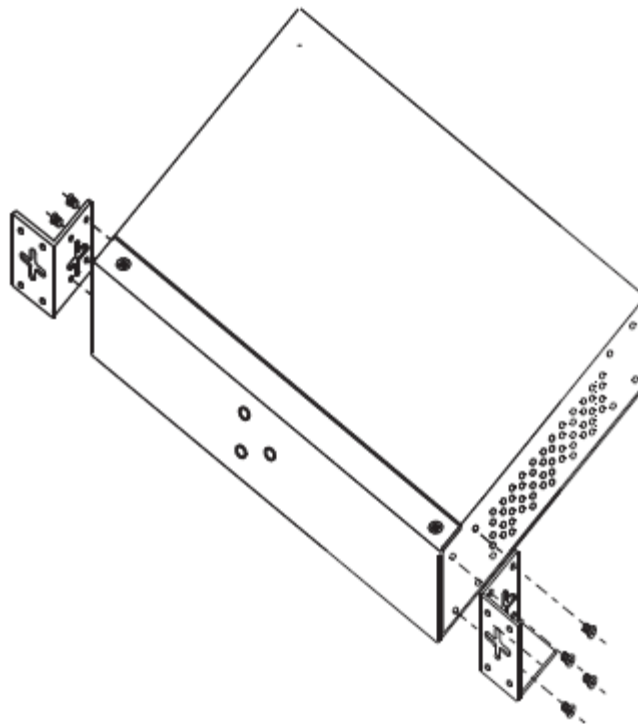

3.3 SIM Card Installation

After disconnecting the power of the device:

1. Un-fasten the screws.
2. Remove the cover

Note: only remove the cover for SIM card installation. DO NOT remove the cover in normal operation.

3. Insert the SIM card into the slot.
4. Put the cover back
5. Fasten the screws.

Note: Make sure the power is off before you install the SIM card.

Cables and Antenna

4.1 Ethernet Cables

The device has standard Ethernet ports. According to the link type, the device uses CAT 3, 4, 5, 5e UTP cables to connect to any other network devices (PCs, servers, switches, routers, or hubs). Please refer to the following table for cable specifications.

Cable Types and Specifications:

Cable	Type	Max. Length	Connector
10Base-T	Cat. 3, 4, 5 100-ohm	UTP 100 m (328 ft)	RJ45
100Base-T(X)	Cat. 5 100-ohm UTP	UTP 100 m (328 ft)	RJ45

With 10/100Base-T(X) cables, pins 1 and 2 are used for transmitting data, and pins 3 and 6 are used for receiving data.

10/100 Base-T(X) RJ-45 Port Pin Assignments:

Pin Number	Assignment
1	TD+
2	TD-
3	RD+
4	Not used
5	Not used
6	RD-
7	Not used
8	Not used

The device supports auto MDI/MDI-X operation. You can use a cable to connect the switch to a PC. The table below shows the 10/100Base-T(X) MDI and MDI-X port pin outs.

10/100 Base-T(X) MDI/MDI-X Pin Assignments:

Pin Number	MDI port	MDI-X port
1	TD+(transmit)	RD+(receive)
2	TD-(transmit)	RD-(receive)
3	RD+(receive)	TD+(transmit)
4	Not used	Not used

5	Not used	Not used
6	RD-(receive)	TD-(transmit)
7	Not used	Not used
8	Not used	Not used

Note: “+” and “-” signs represent the polarity of the wires that make up each wire pair.

4.2 Wireless Antenna

A GSM/DCS/UMT antenna is used for the built-in modem. You can also use an external RF cable and antenna for this connector.



Cellular Antenna

Management

5.1 Network Connection

Before installing the device, you need to be able to access the device via a computer equipped with an Ethernet card or wireless LAN interface. To simplify the connection, it is recommended to use an Ethernet card to connect to a LAN.

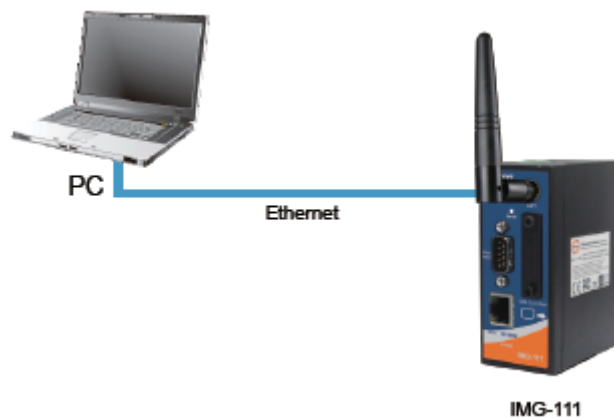

Step 1: Select power source. The device can be powered by +12~48V DC power input.

Step 2: Connect a computer to the device. Use either a straight-through Ethernet cable or cross-over cable to connect the device to a computer. Once the LED of the LAN port lights up, which indicates the connection is established, the computer will initiate a DHCP request to retrieve an IP address from the device.

Step 3: Configure the device on a web-based management utility. Open a web browser on your computer and type <http://192.168.10.1> (default gateway IP of the device) in the address box to access the webpage. A login window will pop up where you can enter the default login name admin and password admin. For security reasons, we strongly recommend you to change the password. Click on **System Tools > Login Setting** after logging in to change the password.

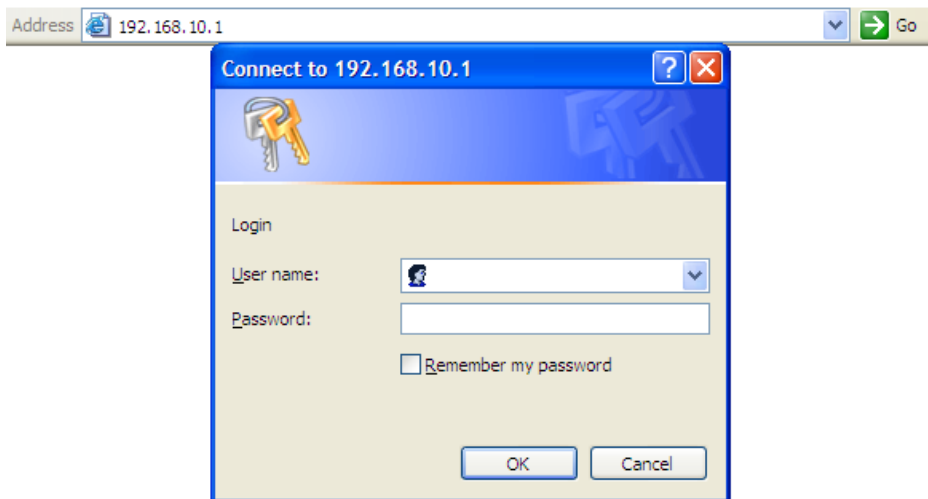

After you log in successfully, a Web interface will appear, as shown below. On the left hand side of the interface is a list of functions where you can configure the settings. The details of the configurations will be shown on the right screen.



5.2 Configuration

On top of the Home screen shows information about the firmware version, uptime, and WAN IP address.

Label	Description
Firmware	Shows the current firmware version
Uptime	Shows the elapsed time since the AP device is started
Wan IP	Shows WAN IP address

5.2.1 Basic Setting

This section will guide you through the general settings for the device.

WAN

This page allows you to configure WAN settings. Different WAN connection types will have different settings.

Basic Setting --> WAN

WAN Settings.

Phone Number:

APN:

User Name:

Password:

Baud Rate:

PIN: Enable PIN check before dialing
PIN Code:

Auto Connect : Enable

Reconnect on Failure: Enable

Fast Mode: Enable

Device Status : Ready.

Operations :

Link Status : Disconnected

Modem Status: Operator:
RadioType:
Signal Quality:

Auto recheck: 00h : 00m : 00s

Label	Description
Phone Number	Telephone number provided by your ISP
APN	Enter the APN value (optional)
User Name	Enter the user name provided by your ISP
Password	Enter the password provided by your ISP
PIN	Enter the PIN code if PIN check is required
Auto Connect	If this option is enabled, the connection will be called up when M2M Gateway boots up
Device Status	Show the status of built-in modem device.
Operations	Click "Connect" to call up the built-in modem. Click "Disconnect" to shut down the connection
Link Status	Show the status of connection, up, down or connecting
Auto recheck	Enable auto refresh modem status per 28 sec

LAN

These are the IP settings of the LAN interface for the IMG-111 M2M Gateway. The LAN IP address is privately for your internal network and cannot be exposed on the Internet.

Basic Setting --> LAN

LAN Side settings.

Router Name:

IP Address:

Subnet Mask:

Label	Description
Router Name	Enter the name of your device
IP Address	The IP address of the LAN. The default value is 192.168.10.1
Subnet Mask	The subnet mask of the LAN. The default value is 255.255.255.0

DHCP

DHCP stands for Dynamic Host Control Protocol. The IMG-111 was built-in DHCP server. The internal DHCP server will assign an IP address to the computers (DHCP client) on the LAN automatically.

Set your computers to be DHCP clients by setting their TCP/IP settings to obtain an IP address automatically. The DHCP server will allocate an unused IP address from the IP address pool to the requesting computer automatically.

Basic Setting --> DHCP -> DHCP Server

Set DHCP Server.

DHCP Server: Enabled Disabled

Starting IP:

Ending IP:

Lease Time: Hours

Local Domain Name: (optional)

Current DHCP Client Information

#	HostName	Mac	IP	Expires In
Static IP Allocation Setup				

Label	Description
DHCP Server	Enables or disables the DHCP server function. The default setting is Enabled .
Starting IP	The starting IP address of the IP range assigned by the DHCP server
Ending IP	The ending IP address of the IP range assigned by the DHCP server

Lease Time	The period of time for the IP address to be leased. During the lease time, the DHCP server cannot assign that IP address to any other clients. Enter a number in the field. The default setting is 48 hours.
Local Domain Name	Enter the local domain name of a private network (optional)
Current DHCP Client Information	List of the computers on your network that are assigned an IP address by internal DHCP server.

IP Allocation

IP allocation provides one-to-one mapping of MAC address to IP address. When computers with the MAC address requesting an IP from IMG-111, it will be assigned with the IP address according to the mapping. You can choose one from the client list and add it to the mapping relationship.

Basic Setting --> DHCP -> IP Allocation

Allocate IP Address Manually.

-- Choose a Client to Edit --

MAC Address	IP Address	
<input type="text"/>	<input type="text"/>	<input type="button" value="Add"/> <input type="button" value="Clear"/>

Static DHCP Client List:

#	MAC Address	IP Address	Operations

Label	Description
Choose a Client to Edit	The list shows the MAC addresses and IP addresses that are already assigned by IMG-111. Choose one from the list and click Copy to button for editing.
MAC Address	The MAC addresses of the computer.
IP Address	The IP address to be related to the MAC address.
Static DHCP Client List	Shows the IP addresses locked to specific MAC addresses

5.2.2 Serial Setting

Remote management

The remote management setting allows user to enable the WAN access of the DS-tool management and serial port access.

Ser2net Setting -->Remote management

Set the Remote Management enable DS-tool to access from WAN.

Remote management: Enable Disable

Port External Access:

Port1: Enable Disable

Label	Description
Remote Management	Enable to managed IMG-111 by DS-tool through WAN access
Port External Access	Enable to allow using of serial data port and control port through WAN access I

Serial Configuration

This page allows you to configure serial port parameters.

Ser2net Setting --> Serial Configuration

	Port1
Port Alias	<input type="text" value="Port1"/>
Interface	<input type="text" value="RS232"/>
Baud Rate	<input type="text" value="38400"/>
Data Bits	<input type="text" value="8"/>
Stop Bits	<input type="text" value="1"/>
Parity	<input type="text" value="None"/>
Flow Control	<input type="text" value="None"/>
Force TX Interval Time	<input type="text" value="0"/> ms
Performance	<input checked="" type="radio"/> Throughput <input type="radio"/> Latency

Label	Description
Port Alias	Remark the port to hint the connected device
Interface	RS422 / RS485(2-wires) / RS485(4-wires)
Baud rate	110bps/300bps/1200bps/2400bps/4800bps/9600bps/19200bps/ 38400bps/57600bps/115200bps
Data Bits	5, 6, 7, 8
Stop Bits	1, 2 (1.5)
Parity	No, Even, Odd, Mark, Space
Flow Control	No, XON/XOFF
Force TX Interval Time	Force TX interval time is to specify the timeout when no data has been transmitted. When the timeout is reached or TX buffer is full (4K Bytes), the queued data will be sent. 0 means disable. Factory default value is 0
Performance	Throughput: This mode is optimized for the highest transmission speed. Latency: This mode is optimized for the shortest response time.

Port Configuration

Ser2net Setting --> Port Configuration

Port1	
Local TCP Port	<input type="text" value="4008"/>
Command Port	<input type="text" value="4009"/>
Mode	Serial to Ethernet
Flush Data Buffer After	<input type="text" value="0"/> ms
Delimiter(Hex 0~ff)	1: <input type="text" value="00"/> 2: <input type="text" value="00"/> 3: <input type="text" value="00"/> 4: <input type="text" value="00"/>
Mode	Ethernet to Serial
Flush Data Buffer After	<input type="text" value="0"/> ms
Delimiter(Hex 0~ff)	1: <input type="text" value="00"/> 2: <input type="text" value="00"/> 3: <input type="text" value="00"/> 4: <input type="text" value="00"/>

Label	Description
Serial to Ethernet	Flush Data Buffer After: The received data will be queued in the buffer until all the delimiters are matched. When the buffer is full (4K Bytes) or after "flush S2E data buffer" timeout, the data will also be sent. You can set the time from 0 to 65535 second.

	<p>Delimiter:</p> <p>You can define max. 4 delimiters (00~FF, Hex) for each way. The data will be hold until the delimiters are received or the option "Flush Serial to Ethernet data buffer" times out. 0 means disable. Factory default is 0</p>
Ethernet to serial	<p>Flush Data Buffer After:</p> <p>The received data will be queued in the buffer until all the delimiters are matched. When the buffer is full (4K Bytes) or after "flush E2S data buffer" timeout, the data will also be sent. You can set the time from 0 to 65535 seconds.</p> <p>Delimiter:</p> <p>You can define max. 4 delimiters (00~FF, Hex) for each way. The data will be hold until the delimiters are received or the option "Flush Ethernet to Serial data buffer" times out. 0 means disable. Factory default is 0</p>

Service Mode

Virtual COM Mode

In Virtual COM mode, the driver establishes a transparent connection between host and serial device by mapping the port of the serial server serial port to a local COM port on the host computer. The Virtual COM mode also supports up to 5 simultaneous connections, so that multiple hosts can send or receive data by the same serial device at the same time.

Ser2net Setting --> Service Mode

	Port1
Data Encryption	<input type="radio"/> Enable <input checked="" type="radio"/> Disable
Service Mode	Virtual COM Mode
Idle Timeout	10 (0~65535)seconds
Alive Check	20 (0~65535)seconds
Max Connection	1 max. connection (1~5)

Apply Cancel

Label	Description
Data Encryption	Use SSL to encrypt data.
Idle Timeout	When serial port stops data transmission for a defined period of time (Idle Timeout), the connection will be closed and the port will be freed and try to connect with other hosts. 0 indicate disable this function. Factory default value is 0 . If Multilink is configured, only the first host connection is effective for this setting.
Alive Check	The serial device will send TCP alive-check package in each

	defined time interval (Alive Check) to remote host to check the TCP connection. If the TCP connection is not alive, the connection will be closed and the port will be freed. 0 indicate disable this function. Factory default is 0.
Max Connection	The number of maximum connections can be supported. The maximum value is 5 , default values is 1 .

*Not allowed to mapping Virtual COM from web

TCP Server Mode

In TCP Server mode, IMG is configured with a unique port combination on a TCP/IP network. In this case, IMG waits passively to be contacted by the device. After the device establishes a connection with the serial device, it can then proceed with data transmission. The TCP Server mode also supports up to 5 simultaneous connections, so that multiple device can receive data from the same serial device at the same time.

Ser2net Setting --> Service Mode

	Port1
Data Encryption	<input type="radio"/> Enable <input checked="" type="radio"/> Disable
Service Mode	TCP Server Mode <input type="button" value="v"/>
TCP Server Port	<input type="text" value="4008"/>
Idle Timeout	<input type="text" value="10"/> (0~65535)seconds
Alive Check	<input type="text" value="20"/> (0~65535)seconds
Max Connection	<input type="button" value="1"/> <input type="button" value="v"/> max. connection(1~5)

Label	Description
Data Encryption	Use SSL to encrypt data.
TCP Server Port	Set the port number for data transmission.
Idle Timeout	When serial port stops data transmission for a defined period of time (Idle Timeout), the connection will be closed and the port will be freed and try to connect with other hosts. 0 indicate disable this function. Factory default value is 0 . If Multilink is configured, only the first host connection is effective for this setting.
Alive Check	The serial device will send TCP alive-check package in each defined time interval (Alive Check) to remote host to check the TCP connection. If the TCP connection is not alive, the

	connection will be closed and the port will be freed. 0 indicate disable this function. Factory default is 0 .
Max Connection	The number of maximum connections can be supported. The maximum value is 5 , default values is 1 .

TCP Client Mode

In TCP Client mode, the device can establish a TCP connection with a server by the method you set (Startup or any character). After the data has been transferred, device can disconnect automatically from the server by using the TCP alive check time or Idle timeout settings.

Ser2net Setting --> Service Mode

	Port1
Data Encryption	<input type="radio"/> Enable <input checked="" type="radio"/> Disable
Service Mode	TCP Client Mode
Destination Host	0.0.0.0 : 4008
Idle Timeout	10 (0~65535)seconds
Alive Check	20 (0~65535)seconds
Connect on	<input checked="" type="radio"/> Startup <input type="radio"/> Any Character
Destination Host	Port
1.	65535
2.	65535
3.	65535
4.	65535

Apply Cancel

Label	Description
Data Encryption	Use SSL to encrypt data.
Destination Host	Set the IP address of host and the port number of data port.
Idle Timeout	When serial port stops data transmission for a defined period of time (Idle Timeout), the connection will be closed and the port will be freed and try to connect with other hosts. 0 indicate disable this function. Factory default value is 0 . If Multilink is configured, only the first host connection is effective for this setting.
Alive Check	The serial device will send TCP alive-check package in each defined time interval (Alive Check) to remote host to check the TCP connection. If the TCP connection is not alive, the connection will be closed and the port will be freed. 0 indicate

	disable this function. Factory default is 0 .
Connect on Startup	The TCP Client will build TCP connections once the connected serial device is started.
Connect on Any Character	The TCP Client will build TCP connections once the connected serial device starts to send data.

UDP Client Mode

Compared to TCP communications, UDP is faster and more efficient. In UDP mode, you can Uni-cast or Multi-cast data from the serial device server to host computers, and the serial device can also receive data from one or multiple host

Ser2net Setting --> Service Mode

Port1	
Service Mode	UDP Mode
Listen Port	4008
Host start IP	Host end IP
1. <input type="text"/>	<input type="text"/>
2. <input type="text"/>	<input type="text"/>
3. <input type="text"/>	<input type="text"/>
4. <input type="text"/>	<input type="text"/>
	Send Port
	65535
	65535
	65535
	65535

Apply Cancel

5.2.3 Advanced Settings

NAT Setting

Virtual Server

Virtual Server is used for setting up public services on the LAN, such as DNS, FTP and Email. Virtual Server is defined as a Local Port to the LAN servers, and all requests from Internet to this Local port will be redirected to the computer specified by the Local IP.

Any PC that was used for a virtual server must have static or reserved IP Address because its IP address may change when requesting IP by DHCP

Advanced Setting --> NAT Setting -> Virtual Server

Virtual server settings.

Virtual Server: Enable Disable

Description:

Public IP: All Specify

Public Port:

Protocol: TCP UDP Both

Local IP:

Local Port:

Enable Now: Yes No

Virtual server list:

#	Description	Public IP	Public Port	Protocol	Local IP	Local Port	Enabled	Ops

Label	Description
Virtual Server	Enable or disable Virtual Server
Description	Enter the description of the entry. Acceptable characters consist of '0-9', 'a-z', 'A-Z'. This field accepts null value.
Public IP	Enter a public IP allowed to access the virtual service. If not specified, choose All .
Public Port	The port number on the WAN (Wide Area Network) side that will be used to access the virtual service.
Protocol	The protocol used for the virtual service
Local IP	The IP address of the computer that will provide virtual service
Local Port	The port number of the service used by the private IP computer
Enable Now	Enables the virtual server entry after adding it
Virtual server list	Click Edit to edit the virtual service entry and Del to delete the entry.

Port Trigger

Some applications require multiple connections, like Internet games, video conferencing, Internet calling and so on. These applications cannot work with a pure NAT M2M Gateway. Port Trigger is used for some of the applications that can work with an NAT M2M Gateway

Advanced Setting --> NAT Setting -> Port Trigger

Port Trigger settings.

Port Trigger: Enable Disable

Description:

Trigger Port:

Trigger Protocol: TCP UDP Both

Incoming Port:

Incoming Protocol: TCP UDP Both

Enable: Yes No

Port Trigger List:

#	Description	Trigger Protocol	Trigger Port	Incoming Protocol	Incoming Port	Enable	Ops
---	-------------	------------------	--------------	-------------------	---------------	--------	-----

Label	Description
Port Trigger	Enable or disable Port Trigger
Description	Enter the description for the entry
Trigger Port	This is the port used to trigger the application.
Trigger Protocol	This is the protocol used to trigger the application.
Incoming Port	This is the port number on the WAN side that will be used to access the application.
Incoming Protocol	This is the protocol used for incoming port.
Enable Now	Enable the rule after adding the entry
Port Trigger List	Click Edit to edit the entry, click Del to delete the entry

DMZ

DMZ (Demilitarized Zone) allows a computer to be exposed to the Internet without passing through the security settings and therefore is unsecured. This feature is useful for special purposes such as gaming.

To use this function, you need to set an internal computer as the DMZ host by entering its IP address. Adding a client to the DMZ may expose your local network to a variety of security risks, so use this function carefully.

Advanced Setting --> NAT Setting -> DMZ

DMZ settings.

DMZ: Enable Disable

Description:

DMZ Host IP:

Label	Description
DMZ	Enables or disables DMZ
Description	Enter a description for the DMZ host entry
DMZ Host IP	Enter the IP address of the computer to act as the DMZ host

UPnP

The UPnP (Universal Plug and Play) feature allows Internet devices to access local host resources or devices as needed. UPnP-enabled devices can be automatically discovered by the UPnP service application on the LAN.

Advanced Setting --> NAT Setting -> UPnP

UPnP settings.

UPnP: Enabled Disabled

Enable NAT-PMP

UPnP List:

#	Application	Ext Port	Protocol	Int Port	IP Address
---	-------------	----------	----------	----------	------------

Label	Description
UPnP	Enable or disable UPnP.
Enable NAT-PMP	NAT-PMP allows a computer in a private network (behind a NAT router) to automatically configure the device to allow parties outside the private network to contact with each other. NAT-PMP operates with UDP. It essentially automates the process of port forwarding. Check the box to enable NAT-PMP.
UPnP List	This table lists the current auto port forwarding information. Application: The application that generates this port forwarding. Ext Port: The port opened on WAN Protocol: The protocol type Int Port: The port redirected to the local computer IP Address: The IP address of local computer to be redirected to

Security Setting

IP Filter

IP filters enable you to control the forwarding of incoming and outgoing data between your LAN and the Internet and within your LAN. This control is implemented via IP filter rules which are defined to block attempts by certain computers on your LAN to access certain types of data or Internet locations. You can also block incoming access to computers on your LAN.

Advanced Setting --> Security Setting -> IP Filter

IP filter settings.

IP Filter: Enable Disable

Description:

Rule:

Direction:

IP Address: Source IP: Destination IP:

Protocol: All ICMP Specify protocol number: TCP Specify port: UDP Specify port:

Enable Now: Yes No

IP filter list:

#	Description	Rule	Direction	Source IP	Destination IP	Protocol	Port	Enabled	Operations
---	-------------	------	-----------	-----------	----------------	----------	------	---------	------------

Label	Description
IP Filter	Enables or disables the IP Filter
Description	Enter description for the entry.
Rule	Configures the rules to be applied to the IP filter. Available options include DROP, ACCEPT, and REJECT.
Direction	Specify the direction of data flow to be filtered
IP Address	Enter the IP address of the source and destination computer
Protocol	Choose which protocol to be filtered.
Enable Now	Enable the entry after adding it
IP Filter List	Click edit for editing the entry, click Del to delete the entry.

MAC Filter

This page enables you to deny or allow LAN computers to access the Internet based on their MAC addresses.

Advanced Setting --> Security Setting -> MAC Filter

MAC Filter settings.

MAC Filter: Enable Disable

Description:

Rule:

MAC Address: (e.x. 00:11:22:aa:bb:cc)

Enable Now: Yes No

MAC filter list:

#	Description	Rule	MAC Address	Enabled	Operations
---	-------------	------	-------------	---------	------------

Label	Description
MAC Filter	Enables or disables the MAC Filter
Description	Enter description for the entry
Rule	Configures the rules to be applied to the MAC filter. Available options include DROP , ACCEPT , and REJECT .
MAC Address	Enter the MAC address to be filtered
Enable Now	Click Yes to enable the entry after adding it
MAC Filter List	Shows the information of all MAC filters.

VPN Setting

Open VPN

Open VPN is a full-functioned SSL VPN solution which can accommodate a wide range of configurations including remote access, site-to-site VPNs, WiFi security, and enterprise-scale remote access solutions with load balancing, failover, and fine-grained access-controls.

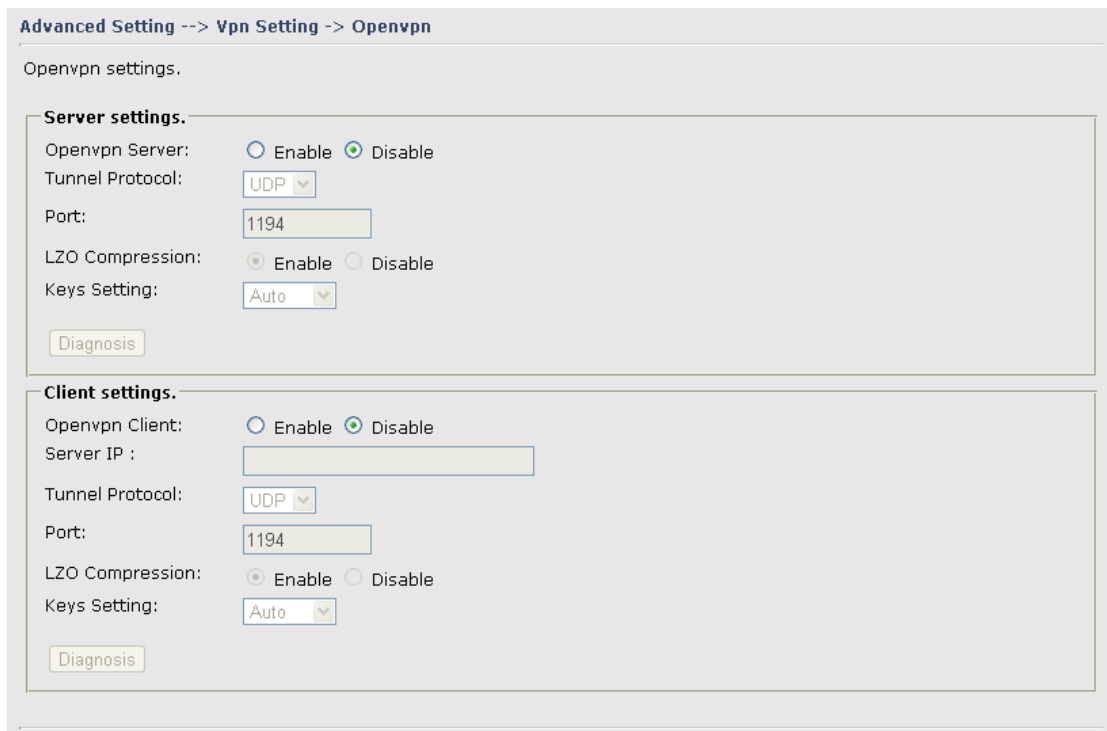

The following topology shows the common use of VPN connection from WAN side

1: Open VPN Server

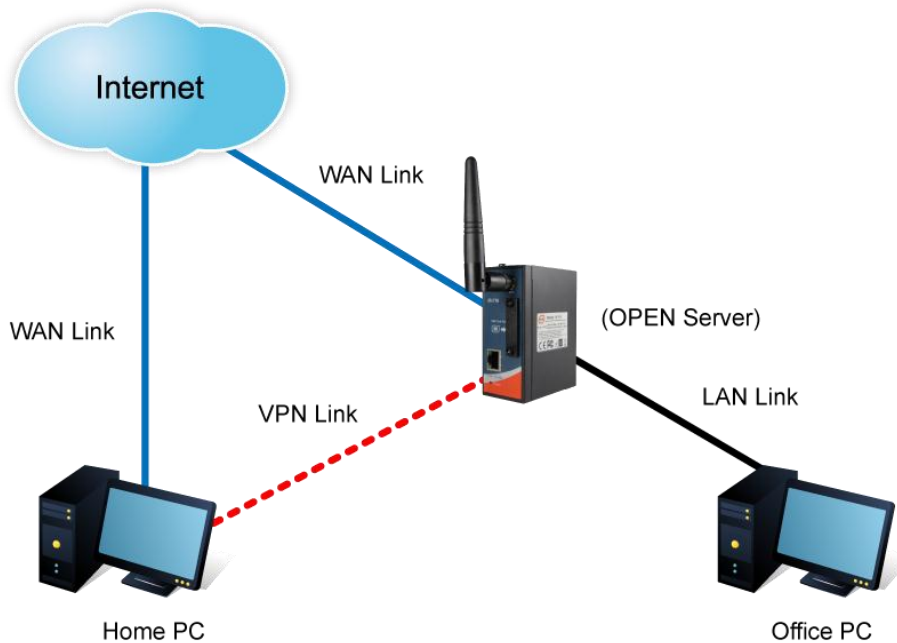

Connection to Open VPN Server

Before connecting to the Open VPN server of IMG-111 M2M Gateway, please install Open VPN client software for your windows PC. It can be downloaded from <http://Open>

VPN.net/download.html#stablel. The current version of Open VPN used in IMG-111 is version 2.0.9. The corresponding software for client should be installed

Label	Description
Open VPN Server	Enables or disables the function of Open VPN server
Tunnel Protocol	Select UDP or TCP protocol depending on your needs. TCP is more reliable than UDP, but UDP performs better than TCP. It is recommended to use UDP if the distance between VPN server and client is short; otherwise, use TCP.
Port	The number of the port (default is 1194).
LZO Compression	Enables or disables the function of LZO Compression
Keys Setting	Select Auto to use preset certificates or Manual to use your certificates. Please install openvpn client software to generate your certificates and paste them here. For more information, please visit openvpn website.

2: Open VPN Client

Two M2M Gateways are needed for creating site-to-site VPN connection using this mode

Label	Description
Open VPN Client	Enables or disables the function of Open VPN client.
Server IP/Host Name	Enter the Open VPN server IP address
Tunnel Protocol	Select UDP or TCP protocol depending on your needs. TCP is more reliable than UDP, but UDP performs better than TCP. It is recommended to use UDP if the distance between VPN server and client is short; otherwise, use TCP.
Port	The number of the port (default is 1194).
LZO Compression	Enables or disables the LZO Compression
Keys Setting	Select Auto to use preset certificates or Manual to use your certificates. Please install openvpn client software to generate your certificates and paste them here. For more information, please visit openvpn website.

3: Open VPN Server VS Client

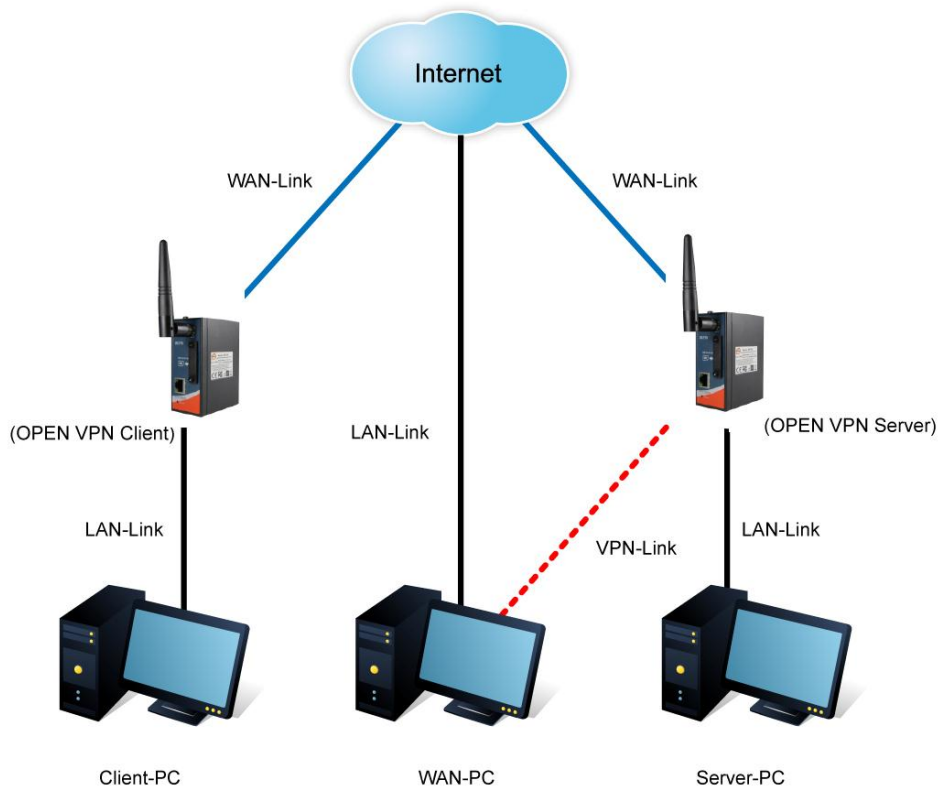

Open VPN Server and Client Connection

The chart above displays the connection of Open VPN Server and Client. The Server IP and Client IP address should configure with the same network domain.

PPTP VPN

PPTP (Point to Point Tunneling Protocol) VPN allows PCs connected to the router through WAN ports to act as PCs in the same LAN.

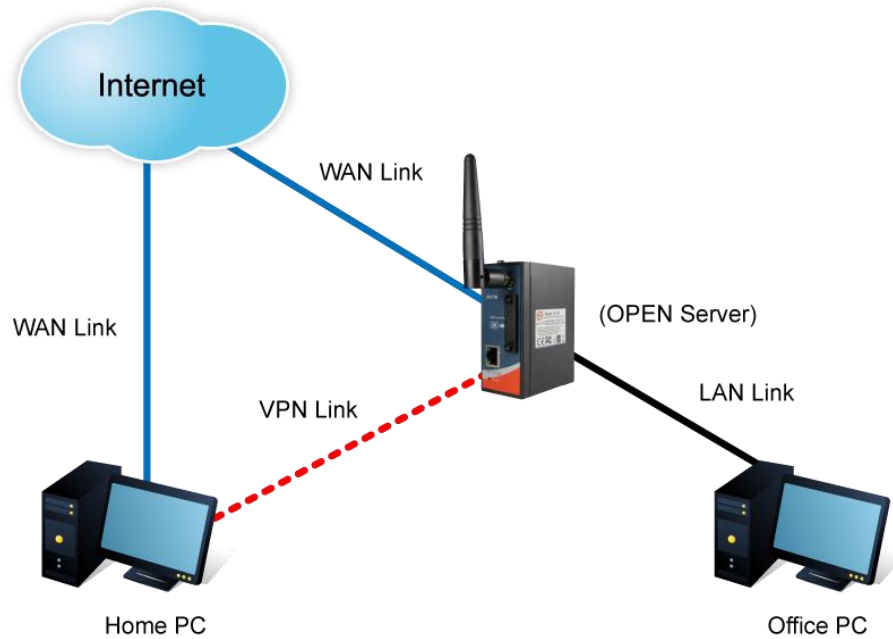

To create a PPTP connection to the router, you must create a new network connection on your Windows PC by right clicking **Network > Property > Create a new connection > Connect to my work space (VPN) > Use VPN to Internet**, and then enter the user name and password set in the page.

After setting up a new connection, you can make configurations in the following page.

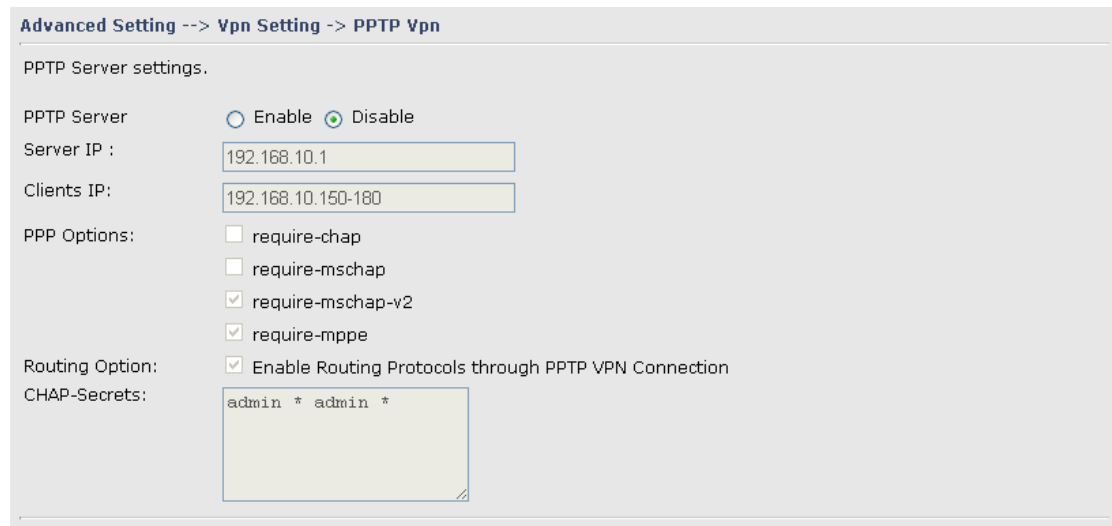

Label	Description
PPTP Server	Enables or disables PPTP VPN server
Server IP	Enter the server IP address. The default value is the IP address of the connected LAN port.
Client IP	Enter the IP address range in the form of 192.168.10.xx-xx. The

	connected client will be assigned with an IP address.
PPP Options	<p>Require-chap: check to use chap authentication on your PPTP server</p> <p>Require-mschap: check to use mschap authentication on your PPTP server</p> <p>Require-mschap-v2: check to use mschap-v2 authentication on your PPTP server</p> <p>Require mppe: check to use MPPE (Microsoft Point-to-Point Encryption) encryption on data transmitted through PPP (Point-to-Point Protocol) and VPN links.</p>
Routing Option	Check to enable routing protocols through PPTP VPN connections
CHAP-Secrets	Enter the username and password pairs in the form of user * pass * . Multiple username and password pairs are allowed.

PPTP Client

If a router wants to link to the device in different networks, you should enable PPTP client in the following page.

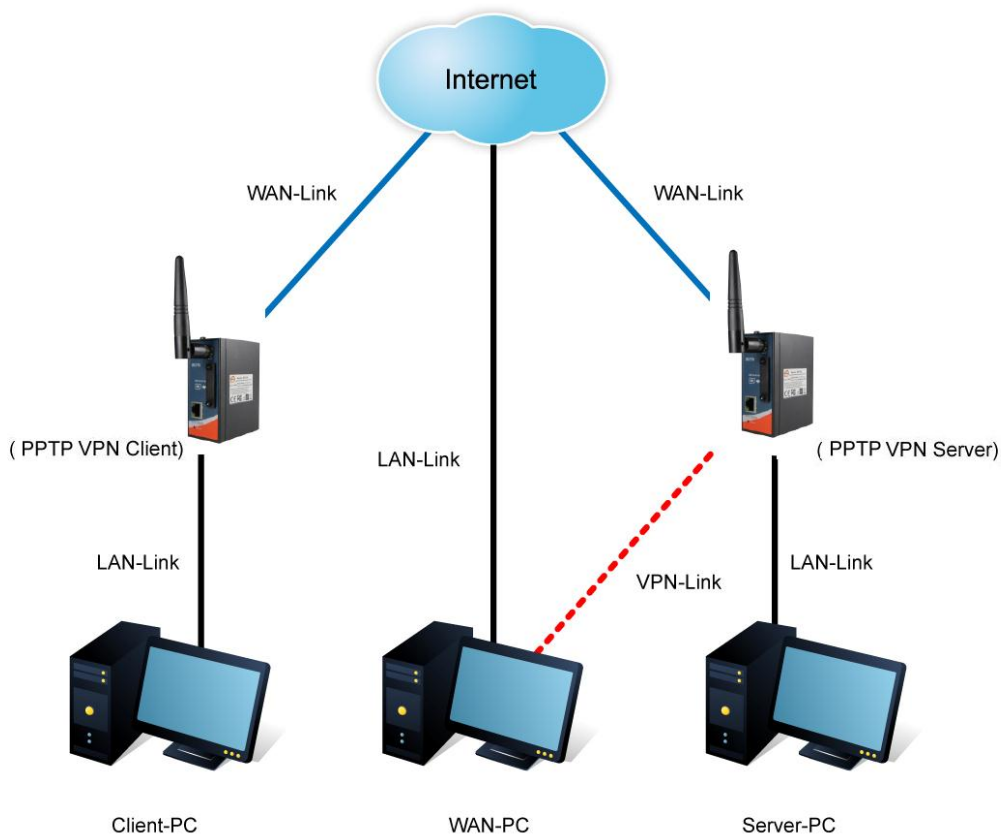

Advanced Setting --> Vpn Setting -> PPTP Client

PPTP Client settings.

PPTP Client Enable Disable

Server IP/Hostname:

Username:

Password:

Options:

- Reconnect on failure
- default route
- require-chap
- require-mschap
- require-mschap-v2
- require-mppe

Routing Option: Enable Routing Protocols through PPTP Client Connection

Operations:

Link Status: Disconnected

Label	Description
PPTP Client	Enables or disables PPTP client
Server IP/Hostname	Enter the server IP address or hostname
Username/Password	Enter the username and password assigned by PPTP server
Options	Choose the rules to be applied Reconnect on failure: prompts automatic reconnection when the link fails. Require-chap: check to use chap authentication on your PPTP server Require-mschap: check to use mschap authentication on your PPTP server Require-mschap-v2: check to use mschap-v2 authentication on your PPTP server Require MPPE: check to use MPPE (Microsoft Point-to-Point Encryption) encryption on data transmitted through PPP (Point-to-Point Protocol) and VPN links.
Operations	Click Connect to link to the server or Disconnect to disconnect from the server
Link Status	Show the status of the link

Routing Protocol Routing Setting

This page shows the information of the routing table. You can configure static and dynamic routing settings in this page.

Current Routing Table:

Destination	Gateway	Subnet Mask	Metric	Interface
192.168.10.0	0.0.0.0	255.255.255.0	0	br0(LAN)
127.0.0.0	0.0.0.0	255.0.0.0	0	lo(LOOPBACK)

Static Routing

When RIPv1 & v2 is **Disabled**, the router will operate in static routing mode, which means devices forward packets using either route information from route table entries that you manually configure or the route information that is calculated using dynamic routing algorithms.

Advanced Setting --> Routing Protocol -> Routing Setting

Current Routing Table:

Destination	Gateway	Subnet Mask	Metric	Interface
192.168.10.0	0.0.0.0	255.255.255.0	0	br0(LAN)
127.0.0.0	0.0.0.0	255.0.0.0	0	lo(LOOPBACK)

Static Route Entry:

Destination	Gateway	Subnet Mask	Metric	Interface	Operations
192.168.11.0	0.0.0.0	255.255.255.0	0	WAN	Commit Delete

Destination	Gateway	Subnet Mask	Metric	Interface	Operation
<input type="text"/>	<input type="text"/>	<input type="text"/>	<input type="text"/>	WAN	Add

Mode:

RIPv1 & v2:

Telnet Setting: Enable Disable

Port:

Password:

Dynamic Routing

Dynamic routing lets routing tables in devices change as the routes change. If the best path to a destination cannot be used, dynamic routing protocols change routing tables when necessary to keep your network traffic moving. Dynamic routing protocols include RIP, OSPF, and BGP; however, the device only supports RIP (Routing Information Protocol).

Do not choose **Disable** in the RIPv1 & v2 list if you want to enable Dynamic Routing. After clicking **Apply**, more information will be displayed in Current Routing Table.

Advanced Setting --> Routing Protocol -> Routing Setting

Current Routing Table:

Destination	Gateway	Subnet Mask	Metric	Interface
192.168.10.0	0.0.0.0	255.255.255.0	0	br0(LAN)
127.0.0.0	0.0.0.0	255.0.0.0	0	lo(LOOPBACK)

Static Route Entry:

Destination	Gateway	Subnet Mask	Metric	Interface	Operations
<input type="text"/>	<input type="text"/>	<input type="text"/>	<input type="text"/>	WAN	<input type="button" value="Add"/>

Mode: Gateway

RIPv1 & v2: Both

Telnet Setting: Enable Disable

Port:

Password:

Label	Description
Current Routing Table	Shows all routing information, including static and dynamic routing (if enabled)
Static Route Entry	Fills in corresponding information to add new entries to the static routing tablet Destination: Specifies the destination network for this static route. Gateway: Specifies the gateway for the destination network that is specified in this static route. Subnet Mask: The Subnet Mask determines which portion of an IP address is the network portion, and which portion is the host portion. Metric: Specifies an integer value of the relative preference of this route against other defined routes that have the same IP address. Interface: Depending on where the Destination IP Address is located, select LAN & WLAN or WAN from the Interface drop-down menu.
Mode	Choose Gateway Mode if you want PCs in the LAN to visit external network, otherwise choose Router Mode
RIPv1 & v2	Choose Disable to disable dynamic routing or other options to configure the interfaces for dynamic routing
Telnet Setting	This option is only available when dynamic routing is enabled. It allows you to make detailed configurations via simple comments.

	<pre> c:\ Telnet 192.168.10.1 % Command incomplete. Hello, this is zebra (version 0.94). Copyright 1996-2002 Kunihiro Ishiguro. [APR654978] enable Turn on privileged mode command exit Exit current mode and down to previous mode list Print command list ping send echo messages quit Exit current mode and down to previous mode show Show running system information telnet Open a telnet connection traceroute Trace route to destination </pre>
Port	Enter a port number for the entry
Password	Enter a password for the entry

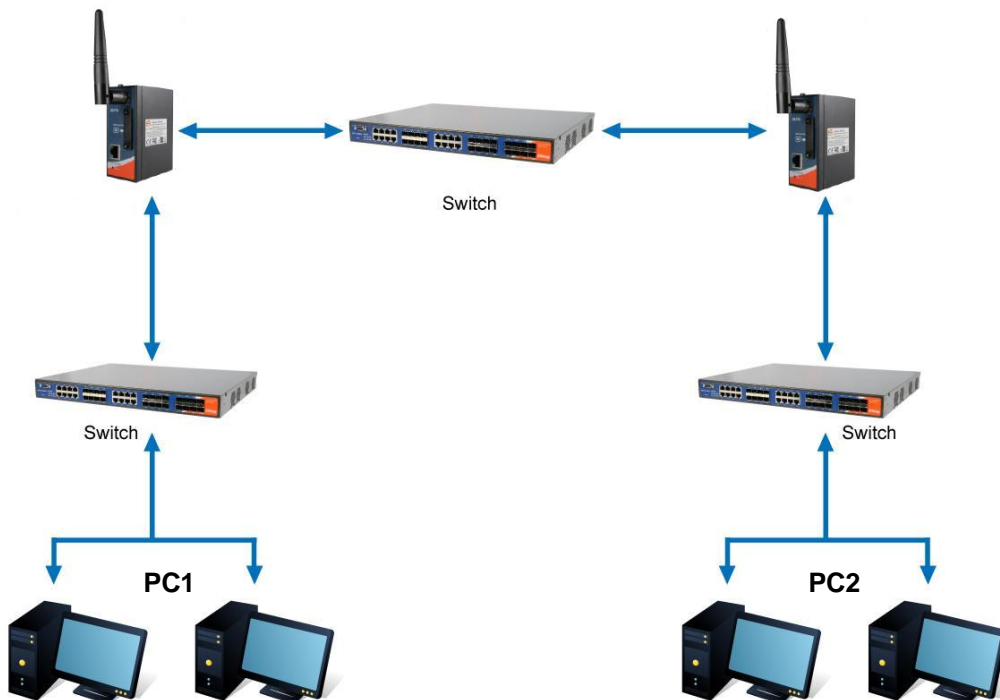

Routing Topography

Miscellaneous

DDNS

DDNS (Dynamic Domain Name System) allows you to configure a domain name for your IP address which is dynamically assigned by your ISP. Therefore, you can use a static domain name that always points to the current dynamic IP address.

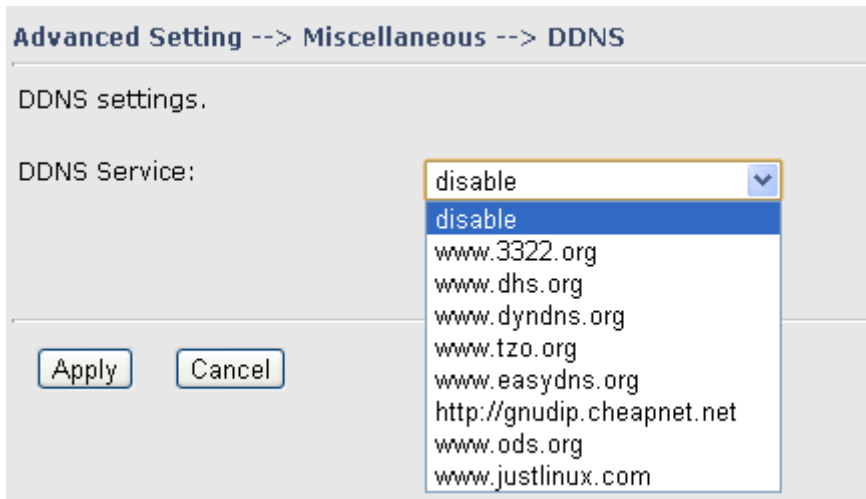

Label	Description
DDNS Service	Choose a DDNS service provider from the list

5.2.4 System Tools

Date & Time

In this page, you can set the date & time of the device. A correct date and time will help the system log events. You can set up a NTP (Network Time Protocol) client to synchronize date & time with a NTP server on the Internet.

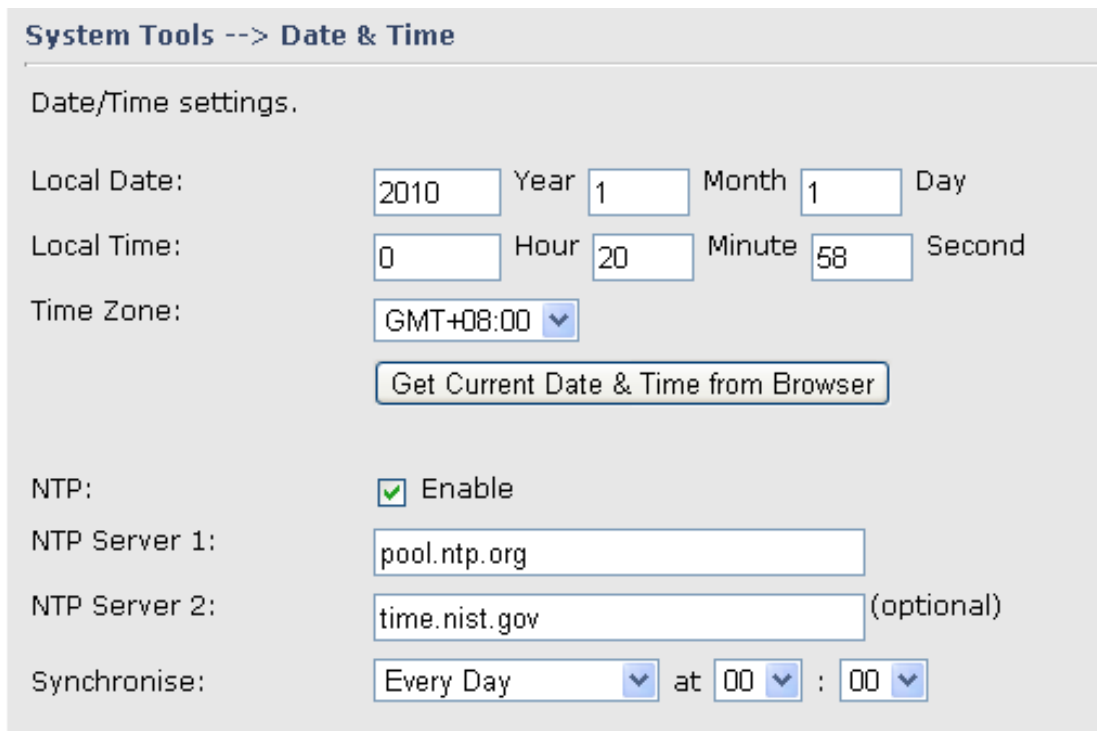

Label	Description
Local Date	Set a local date manually
Local Time	Set local time manually.
Time Zone	Select the time zone manually
Get Current Date & Time from Browser	Click this button; you can set the time from your browser
NTP	Enable or disable NTP function to synchronize time from the NTP server
NTP Server 1	The primary NTP Server
NTP Server 2	The secondary NTP Server
Synchronize	This is the scheduled time when the NTP synchronization performed

System Event

When the WAN Link Down option is enabled, the system will notify you when the link is down.

System Tools --> System Event

WAN Link Down Alarm

Disable WAN Link Down Alarm

Enable WAN Link Down Alarm

Login Setting

You can change login name and password in page. The default login name and password are both **admin**.

System Tools --> Login Setting

Login settings.

Old Login Name: admin

Old Password:

New Login Name:

New Password:

Confirm New Password:

Web Protocol: HTTP HTTPS

Port:

Label	Description
Old Name	This field shows the old login name.
Old Password	Type in current password
New Name	Enter a new login name. Acceptable characters contain '0-9', 'a-z', 'A-Z' and the length must be 1 to 15 characters. An empty name is not acceptable.
New Password	Enter a new login password. Acceptable characters contain '0-9', 'a-z', 'A-Z' and the length must be 0 to 15 characters.
Confirm New Password	Retype the new password to confirm it.
Web Protocol	Choose a web management page protocol from HTTP and HTTPS . HTTPS (HTTP over SSL) encrypts data sent and received over the Web. Choose HTTPS if you want a secure connection.
Port	Choose a web management page port number. For HTTP, default port is 80. For HTTPS, default port is 443.

M2M Gateway Restart

If you want restart the M2M Gateway through the Warm Reset, click Restart Now to restart the Wireless M2M Gateway. Also, you can set a Scheduling time to make the M2M Gateway restart

System Tools --> Router Restart

Router Restart Utility.

Scheduling: Enable

Restart at :

Label	Description
Restart Now	Click to restart the M2M Gateway via warm reset
Scheduling	Enable: check to activate the setting Restart at: specify the time for resetting the M2M Gateway. You can configure the action to be performed periodically.

Firmware Upgrade

Newer firmware may provide better performance or function extensions. To upgrade the new firmware, you need a firmware file which matches the model of this M2M Gateway. It will take several minutes to upload and update the firmware.

After the upgrade is done successfully, reboot the M2M Gateway to utilized new firmware

System Tools --> Firmware Upgrade

Do NOT power off the router while upgrading!

Current Firmware Version: 1.0i



During firmware upgrading, do not turn off the power or press the reset button.

Save/Restore Configurations

This page allows you to save configurations or return settings to previous status. You can download the configuration file from the Web. Note: users using old versions of Internet Explorer may have to click on the warning on top of the browser and choose Download File.

System Tools --> Save/Restore Configurations

Save/Restore Configurations.

Save Current Configurations

Restore previous saved configurations

Restore factory default settings

Label	Description
Save	Click to save existing configurations as a file for future usage.
Select File	You can restore configurations to previous status by installing a previous configuration file. To do this, choose Web Restore or Tftp Restore . If you choose Web Restore , you need to choose a file and click Web Restore . If you select Tftp Restore , fill in a Tftp server IP address and the file name before clicking Tftp Restore .
Restore Factory Default Setting	You may also reset the M2M Gateway to the factory settings by clicking on Restore Default Settings. The M2M Gateway will reboot to validate the default settings.

Remote Management

Set the Remote Management to access the M2M Gateway web pages from WAN side.

System Tools --> Remote Management

Set the Remote Management to access the Router web pages from WAN side.

Remote Management: Enable Disable

Management Port:

Permission: Any Host

Host with IP address:

Host within IP range: -

Label	Description
Remote Management	Enables or disables remote management function

Management Port	Enter the port number that will be open to outside access. This port must be used when you establish a remote connection.
Permission	You can grant remote access to specific users. Tick Any Host or enter a hostname or IP address if you only want a specific computer or device to be able to access the device.

Miscellaneous (Ping)

This page enables you to run ping test which will send out ping packets to test if a computer is on the Internet or if the WAN connection is OK. Enter a domain name or IP address in the destination box and click **Ping** to test.

System Tools --> Miscellaneous

Miscellaneous utilities.

Ping Test: Destination:

Ping Test Result:

5.2.5 System Status

System Info

This page displays the details information for the M2M Gateway including model name, model description, firmware version, WAN, LAN settings.

System Status --> System Info

System Info.

Model:	IMG-111	
Model Description:	M2M 1 Port Serial Gateway	
WAN:	Mode	Modem/3G
LAN:	IP Address	192.168.10.1
	Subnet Mask	255.255.255.0
	MTU	1500
	MAC Address	00:32:12:31:31:31
	DHCP Server	Enabled

System Log

The M2M Gateway keeps a running log of events and activities occurring on the M2M Gateway, several filters are provided for displaying related log entries.

Click the button 'Refresh' to refresh the page.

Click the button 'Clear Logs' to clear the log entries.

System Status --> System Log

System log.

Log Option:

DHCP Server
 NTP Client
 Firewall

Boot Message
 UPNP
 Modem

System Log:

#	Date Time	Item	Content

Traffic Statistics

This page displays network traffic statistics for packets both received and transmitted through Ethernet ports and wireless connections.

System Status --> Traffic Statistics

Traffic statistics.

Interface	Send	Receive
LAN	592916 Bytes (1433 Packets)	178571 Bytes (1468 Packets)
WAN	0 Bytes (0 Packets)	0 Bytes (0 Packets)

5.3 DS-tool

The IMG basic information and some serial port related function can be configure by using DS-tool, including the VCOM Mapping.

5.3.1 General settings

This page display some basic information of the device and also includes the setting of device name.

General | Security | Ethernet | Upgrade Firmware | Reboot Device

Model

LAN IP Address LAN MAC Address Version

Device Name/Location

Label	Description
Device Name/location	Input the name of the device.

5.3.2 Security

General | Security | Ethernet | Upgrade Firmware | Reboot Device

Password

New Password

Confirm New Password

Old Password

Label	Description
New Password	Enter a new login password.
Confirm New Password	Retype the new password to confirm it.
Current Password	Type in current password

5.3.3 Network Setting

General | Security | Ethernet | Upgrade Firmware | Reboot Device

LAN

LAN IP

IP Address

Netmask

Label	Description
IP Address	Assigning an IP address.
Network	All devices on the network must have the same subnet mask to communicate with each other on the network.

5.3.4 Upgrade Firmware

General | Security | Ethernet | Upgrade Firmware | Reboot Device

Firmware Image

Label	Description
Firmware Image	Browse to the location where the firmware image file is located and click update.

5.3.5 Reboot Device

General | Security | Ethernet | Upgrade Firmware | Reboot Device

Reboot Device

Label	Description
Reboot Device	Click to reboot the device (warm start).

5.3.6 Serial Settings

Label	Description
Port Alias	Remark the port to hint the connected device
Interface	RS232
Baud rate	110bps/300bps/1200bps/2400bps/4800bps/9600bps/19200bps/ 38400bps/57600bps/115200bps
Data Bits	5, 6, 7, 8
Stop Bits	1, 2 (1.5)
Parity	No, Even, Odd, Mark, Space
Flow Control	No, XON/XOFF
Performance	Throughput: This mode optimized for highest transmission speed. Latency: This mode optimized for shortest response time.
Serial to Ethernet	Delimiter: You can define max. 4 delimiters (00~FF, Hex) for each way. The data will be hold until the delimiters are received or the option "Flush Serial to

	<p>Ethernet data buffer" times out. 0 means disable. Factory default is 0.</p> <p>Flush Data Buffer After:</p> <p>The received data will be queuing in the buffer until all the delimiters are matched. When the buffer is full (4K Bytes) or after "flush S2E data buffer" timeout the data will also be sent. You can set the time from 0 to 65535 seconds</p>
Ethernet to Serial	<p>Delimiter:</p> <p>You can define max. 4 delimiters (00~FF, Hex) for each way. The data will be hold until the delimiters are received or the option "Flush Ethernet to Serial data buffer" times out. 0 means disable. Factory default is 0.</p> <p>Flush Data Buffer After:</p> <p>The received data will be queuing in the buffer until all the delimiters are matched. When the buffer is full (4K Bytes) or after "flushE2S data buffer" timeout the data will also be sent. You can set the time from 0 to 65535 seconds.</p>
Force TX Interval Time	<p>Force TX interval time is to specify the timeout when no data has been transmitted. When the timeout is reached or TX buffer is full (4K Bytes), the queued data will be sent. 0 means disable. Factory default value is 0.</p>

5.3.7 Service Mode

Virtual COM Mode

In Virtual COM Mode, The driver establishes a transparent connection between host and serial device by mapping the Port of the serial server serial port to local COM port on the host computer. Virtual COM Mode also supports up to 5 simultaneous connections, so that multiple hosts can send or receive data by the same serial device at the same time.

Label	Description
Encryption with SSL	Use SSL to encrypt data.
Map Virtual COM	Select a Virtual COM name to map to.
Idle Timeout	When serial port stops data transmission for a defined period of time (Idle Timeout), the connection will be closed and the port will be freed and try to connect with other hosts. 0 indicate disable this function. Factory default value is 0 . If Multilink is configured, only the first host connection is effective for this setting.
Alive Check	The serial device will send TCP alive-check package in each defined time interval (Alive Check) to remote host to check the TCP connection. If the TCP connection is not alive, the connection will be closed and the port will be freed. 0 indicate disable this function. Factory default is 0 .

Max Connection	The number of maximum connections can be supported. The maximum value is 5 , default values is 1 .
----------------	--

*Mapping Virtual COM from web is not allowed.

TCP Server Mode

In TCP Server Mode, IMG is configured with a unique Port combination on a TCP/IP network. In this case, IMG waits passively to be contacted by the device. After a connection is established, it can then proceed with data transmission. TCP Server mode also supports up to 5 simultaneous connections, so that multiple device can receive data from the same serial device at the same time.

Label	Description
Encryption with SSL	Use SSL to encrypt data
Data Port	Set the port number for data transmission.

Auto Scan	Scan the data port automatically.
Idle Timeout	When serial port stops data transmission for a defined period of time (Idle Timeout), the connection will be closed and the port will be freed and try to connect with other hosts. 0 indicate disable this function. Factory default value is 0. If Multilink is configured, only the first host connection is effective for this setting.
Alive Check	The serial device will send TCP alive-check package in each defined time interval (Alive Check) to remote host to check the TCP connection. If the TCP connection is not alive, the connection will be closed and the port will be freed. 0 indicate disable this function. Factory default is 0.
Max Connection	The number of maximum connections can be supported. The maximum value is 5, default values is 1.

TCP Client Mode

In TCP Client Mode, device can establish a TCP connection with server by the method you have settled (Startup or any character). After the data has been transferred, device can disconnect automatically from the server by using the TCP alive check time or Idle time settings.

The screenshot shows a web-based configuration interface for 'port1' in 'Service Mode'. The 'TCP Client Mode' section includes a 'TCP Client Settings' panel with checkboxes for 'Encryption with SSL' and 'Enable Control Port'. It also has input fields for 'Destination Host' and 'Port' (set to 4000) with an 'Auto Scan' button. A 'Misc.' panel contains 'Idle Timeout' and 'Alive Check' (both set to 0) and a 'Connect on' dropdown set to 'Startup'. Below this is a 'Multilink' section with four rows, each with 'Destination Host', 'Port', and 'Auto Scan' fields. At the bottom are 'Refresh', 'Apply Only', and 'Apply and Save' buttons.

Label	Description
Encryption with SSL	Use SSL to encrypt data.
Destination Host	Set the IP address of the host.
Port	Set the port number of data port.
Idle Timeout	When serial port stops data transmission for a defined period of time (Idle Timeout), the connection will be closed and the port will be freed and try to connect with other hosts. 0 indicate disable this function. Factory default value is 0 . If Multilink is configured, only the first host connection is effective for this setting.
Alive Check	The serial device will send TCP alive-check package in each defined time interval (Alive Check) to remote host to check the TCP connection. If the TCP connection is not alive, the connection will be closed and the port will be freed. 0 indicate disable this function. Factory default is 0 .
Connect on Startup	The TCP Client will build TCP connections once the connected

	serial device is started.
Connect on Any Character	The TCP Client will build TCP connections once the connected serial device starts to send data.

UDP Mode

Compared to TCP communications, UDP is faster and more efficient. In UDP mode, you can Uni-cast or Multi-cast data from the serial device server to host computers, and the serial device can also receive data from one or multiple host

Serial Settings
Service Mode

port1
 Service Mode UDP Mode

UDP Mode

UDP Settings
 Listening Port 4000

 Auto Scan

Multilink

	Destination Host Begin	to	Destination Host End	to	Sending Port	
1	<input style="width: 80%;" type="text"/>		<input style="width: 80%;" type="text"/>		<input style="width: 50%;" type="text"/>	Auto Scan
2	<input style="width: 80%;" type="text"/>		<input style="width: 80%;" type="text"/>		<input style="width: 50%;" type="text"/>	Auto Scan
3	<input style="width: 80%;" type="text"/>		<input style="width: 80%;" type="text"/>		<input style="width: 50%;" type="text"/>	Auto Scan
4	<input style="width: 80%;" type="text"/>		<input style="width: 80%;" type="text"/>		<input style="width: 50%;" type="text"/>	Auto Scan

Refresh

Apply Only

Apply and Save

Technical Specifications

ORing M2M Model	IMG-111	IMG-111-2G
Physical Ports		
10/100 Base-T(X) Ports in RJ45 Auto MDI/MDIX		1
Sim card slot		1
Cellular Interface		
Cellular Standard	GSM / GPRS / EGPRS / EDGE / WCDMA / HSDPA / HSUPA	GSM / GPRS
Band options	Dual band : HSUDPA 1900 / 2100 MHz Quad band : GSM / GPRS / EDGE 850 / 900 / 1800 / 1900 MHz / WCDMA / HSDPA 850 / 900 / 1900 / 2100MHz	Dual-band (Qual-band) GSM/GPRS 900/1800MHz or 900MHz/1800MHz/850MHz/1900MHz
Antenna Connector	Reverse SMA	
Antenna	GSM/DCS/UMT antenna x1	
Serial Ports		
Connector	DB9 Male x 1	
Operation Mode	RS-232	
Serial Baud Rate	110 bps to 115.2 Kbps	
Data Bits	5, 6, 7, 8	
Parity	odd, even, none, mark, space	
Stop Bits	1, 1.5, 2	
Serial signals	RS-232 : TxD, RxD, GND	
LED Indicators		
Power indicator	Green On: Power is on and functioning Normally.	
Status indicator	Green : System status indicator	
Fault indicator	Amber on : WAN connection link down	
WAN	Green on : 2G/3.5G dial up Green blinking : 2G/3.5G disconnect	
Serial TX/RX LED	Red : Receiving data Green : Transmitting data	
10/100TX RJ45 port indicator	Green for port Link/Act.	
Fault Contac		
Relay	Relay output to carry capacity of 1A at 24VDC	
Power		
Power input	12-48VDC power input on terminal block	
Power consumption	4.5 Watts	
Physical Characteristic		
Enclosure	IP-30	
Dimension (W x D x H)	41 (W) x 70 (D) x 95 (H) mm (1.61 x 2.76 x 3.74 inch)	
Weight (g)	360 g	
Environmental		
Storage Temperature	-40 to 85°C (-40 to 185°F)	
Operating Temperature	-10 to 60°C (14 to 140°F)	

Operating Humidity	5% to 95% Non-condensing
Regulatory Approvals	
EMI	FCC Part 15, CISPR (EN55022) class A
EMS	EN61000-4-2 (ESD), EN61000-4-3 (RS), EN61000-4-4 (EFT), EN61000-4-5 (Surge), EN61000-4-6 (CS), EN61000-4-8, EN61000-4-11
Shock	IEC60068-2-27
Free Fall	IEC60068-2-32
Vibration	IEC60068-2-6
Safety	EN60950-1
Warranty	3 years