

**EDAM-5000 Series
USB, Ethernet, RS232/485 Remote Module
User's Manual**

Web Site: www.inlog.com.tw

Trademark:

The names used in this manual for identification only maybe registered trademarks of their respective companies

Rev 2.2 September 12, 2012

Chapter 1	Major Features.....	10
1.1	Multi-Interface DA&C I/O Modules.....	10
1.2	Intelligent I/O Modules.....	10
1.3	Mixed I/O In One Module To Fit All Applications.....	10
1.4	Modbus/TCP and RTU Protocol Supported For Open Connectivity.....	10
1.5	Software Support.....	10
1.6	Common Technical Specification Of EDAM-5000.....	11
1.7	Dimensions.....	12
1.8	System Requirements.....	14
1.9	I/O Modules Wiring.....	14
Chapter 2	Specifications.....	15
2.1	EDAM-5015 Specifications.....	15
2.2	EDAM-5017 Specifications.....	16
2.3	EDAM-5019 Specifications.....	17
2.4	EDAM-5028 Specifications.....	18
2.5	EDAM-5029 Specifications.....	19
2.6	EDAM-5060 Specifications.....	20
Chapter 3	Connector/Pin Assignment.....	21
3.1	EDAM-5015 Front Side Connectors.....	21
3.2	EDAM-5017 Front Side Connectors.....	23
3.3	EDAM-5019 Front Side Connectors.....	25
3.4	EDAM-5028 Front Side Connectors.....	27
3.5	EDAM-5029 Front Side Connectors.....	29
3.6	EDAM-5060 Front Side Connectors.....	31
3.7	EDAM-5000 Rear Side Connectors.....	33
3.7.1	ID Address Switch Is Used For Setting ID Address Of Module.....	33
3.7.2	Communication Interfaces (RS485 ,RS232 ,or CAN bus).....	34
3.7.3	EDAM-5000 Reset Switch And CJC Sensor.....	34
3.7.4	EDAM-5015 Analog/Digital I/O Block Diagram.....	35
3.7.5	EDAM-5017 Analog/Digital I/O Block Diagram.....	35
3.7.6	EDAM-5019 Analog/Digital I/O Block Diagram.....	36
3.7.7	EDAM-5028 Analog/Digital I/O Block Diagram.....	36
3.7.8	EDAM-5029 Analog/Digital I/O Block Diagram.....	37
3.7.9	EDAM-5060 Analog/Digital I/O Block Diagram.....	37
Chapter 4	Application Wiring.....	38
4.1	EDAM-5015 Wiring.....	38
4.2	EDAM-5017 wiring.....	39
4.3	EDAM-5019 Wiring.....	41
4.4	EDAM-5028 Wiring.....	43

4.5	EDAM-5029 Wiring.....	45
4.6	EDAM-5060 Wiring.....	47
Chapter 5	Modbus Command Structure	49
5.1	Command Structure	49
5.2	Modbus Function Code Introductions.....	50
Chapter 6	Modbus Address Mapping	51
6.1	Modbus Mapping Of EDAM-5015	51
6.1.1	Register Address (Unit : 16 bits).....	51
6.1.2	Bit Address (Unit : 1 bit)	51
6.2	Modbus Mapping Of EDAM-5017	52
6.2.1	Register Address (Unit : 16 bits).....	52
6.2.2	Bit Address (Unit: 1 bit)	53
6.3	Modbus Mapping Of EDAM-5019	54
6.3.1	Register Address (Unit: 16 bits).....	54
6.3.2	Bit Address (Unit: 1 bit)	55
6.4	Modbus Mapping Of EDAM-5028	56
6.4.1	Register Address (Unit: 16 bits).....	56
6.4.2	Bit Address (Unit: 1 bit)	56
6.5	Modbus Mapping Of EDAM-5029	57
6.5.1	Register Address (Unit: 16 bits).....	57
6.5.2	Bit Address (Unit: 1 bit)	57
6.6	Modbus Mapping Of EDAM-5060	58
6.6.1	Register Address (Unit: 16 bits).....	58
6.6.2	Bit Address (Unit: 1 bit)	58
Chapter 7	Modbus Data Conversion.....	59
7.1	How To Calculate DI Counter Value.....	59
7.2	How To Convert Modbus Data To AI Voltage/Temperature.....	60
7.2.1	Engineering Data Format Table.....	60
7.2.2	Hex 2's Complement Data Format Table	61
Chapter 8	Analog And Digital I/O Channel Type	62
8.1	DI Channel Types	62
8.2	AI Channel Types.....	62
Chapter 9	TCP/IP Port Assignments.....	63
Chapter 10	ASCII Commands	64
10.1	Common Commands	64
10.2	Digital Commands	64
10.3	Analog Commands.....	65
10.4	Command Description	66
10.4.1	\$AACRC Read CRC Status	66
10.4.2	\$AACRCv Set CRC	66

EDAM-5000 User's Manual

10.4.3	\$AA5	Read The Reset status	66
10.4.4	\$AAF	Read The Firmware Version	67
10.4.5	\$AAGATE	Read Gateway Address.....	67
10.4.6	\$AAGATEnnnnnnnn	Set Gateway Address.....	67
10.4.7	\$AAIP	Read IP Address.....	68
10.4.8	\$AAIPnnnnnnnn	Set IP Address	68
10.4.9	\$AAM	Reads The Module Name.....	68
10.4.10	~AAO(name)	Set The Module Name.....	69
10.4.11	\$AAMASK	Read Mask Address	69
10.4.12	\$AAMASKnnnnnnnn	Set Mask Address	69
10.4.13	\$AAP	Read The Communication Protocol.....	70
10.4.14	\$AAPv	Set The Communication Protocol	70
10.4.15	\$AASW	Read Web Server Status	70
10.4.16	\$AASWv	Enabled/Disable Web Server.....	71
10.4.17	\$AADHCP	Read DHCP Status	71
10.4.18	\$AADHCPv	Enabled/Disable DHCP.....	71
10.4.19	^AAMAC	Read MAC Address.....	72
10.4.20	~AA6v	Set Module Led Control	72
10.4.21	~AA6ddddddd	Write Data To Led Board.....	72
10.4.22	~AA6dddddddnnnn	Force Led To Flash	73
10.4.23	~AA3ettttddd	Write Communication Timeout settings	73
10.4.24	~AA3	Read Communication Timeout settings	74
10.4.25	#AA	Read The Analog Inputs Of All	74
10.4.26	#AA n	Read The Single Analog Input	75
10.4.27	#AAMH	Read Maximum Value Of All Channels.....	75
10.4.28	#AAMHn	Read Maximum Value Of Specified Channel	76
10.4.29	\$AAMH	Clear All Maximum Value	76
10.4.30	\$AAMHn	Clear Maximum Value Of Specified Channel	77
10.4.31	#AAML	Read Minimum Value Of All Channels	77
10.4.32	#AAMLn	Read Minimum Value Of Specified Channel	78
10.4.33	\$AAML	Clear All Minimum Value.....	78
10.4.34	\$AAMLn	Clear Minimum Value Of Specified Channel	79
10.4.35	#AAAV	Read Average Value	79
10.4.36	\$AAE	Read Channel Average Enable/Disable Status	80
10.4.37	\$AAEnnnn	Disable/Enable Channel in Average	80
10.4.38	#AAAL	Read AD High/Low Alarm Status	81
10.4.39	\$AAAHnnnn	Clear A/D High Alarm	81
10.4.40	\$AAALnnnn	Clear A/D Low Alarm.....	82
10.4.41	\$AAB	Read Channel Burnout Status.....	82
10.4.42	%AAB	Read Channel Burnout Enable/Disable Status.....	83

EDAM-5000 User's Manual

10.4.43	%AABn	Enable/Disable Burnout Detection	83
10.4.44	\$AA3	Read The CJC Temperature	84
10.4.45	~AAC	Read The CJC Enable/Disable	84
10.4.46	~AACn	Enable/Disable The CJC.....	85
10.4.47	\$AA9snnnn	Set The All Channel CJC Offset	85
10.4.48	\$AA9c	Read Single Channel CJC Offset.....	86
10.4.49	\$AA9cSnnnn	Set Single Channel CJC Offset.....	86
10.4.50	\$AAR	Read AD Filter Value.....	87
10.4.51	\$AARf	Set AD Filter Value	87
10.4.52	\$AA6	Read the Channel Enable/Disable Status.....	88
10.4.53	\$AA5vvv	Enable/Disable A/D Channels.....	88
10.4.54	\$AA8Ci	Read the Single A/D Channel Range.....	89
10.4.55	\$AA7CiRrr	Set the Single Channel Range	89
10.4.56	\$AAS1	Reload the Default configuration	89
10.4.57	@AA	Read the Digital I/O Status.....	90
10.4.58	@AAnn	Set the Digital Output Channels	90
10.4.59	@AAnnnn	Set the Digital Output Channels.....	91
10.4.60	@AAnnnnnn	Set The Digital Output Channels	91
10.4.61	#AA0Ann	Set The Digital 1's Byte(DO0~DO7) Output.....	91
10.4.62	#AA0Bnn	Set The Digital 2's Byte(DO8~DO15) Output.....	92
10.4.63	#AA0Cnn	Set the Digital 3's byte(DO16~DO23) Output	92
10.4.64	#AAnn	Read Digital Input Counter.....	92
10.4.65	\$AACn	Clear Digital Input Counter	93
10.4.66	\$AACnn	Clear Digital Input Counter	93
10.4.67	\$AALS	Read The Latched DI Status	93
10.4.68	\$AAC	Clear the latched DI status.....	94
10.4.69	\$AA9nn	Read Single Do Pulse High/Low Width.....	94
10.4.70	\$AA9nnhhhhlll	Set Single Do Pulse High/Low Width.....	94
10.4.71	\$AAAnn	Read Single Do High/Low Delay Width.....	95
10.4.72	\$AAAnnhhhhlll	Set Single Do High/Low Delay Width	95
10.4.73	\$AABnn	Read Single Do Pulse Counts.....	96
10.4.74	#AA2ncccc	Write Single Do Pulse Counts	96
10.4.75	#AA3nns	Start/Stop DO Pulse Counts.....	96
10.4.76	#AA3nnnnnnn	Start/Stop multiple DO Pulse Counts	97
10.4.77	~AA4v	Read The Power On/Safe Value	97
10.4.78	~AA5v	Set Current Do Value As Power On/Safe Value.....	97
10.4.79	~AA5vnnnnnn	Set Specified Value As Power On/Safe Value.....	98
10.4.80	~AAD	Read DI/O Active State.....	98
10.4.81	~AADvn	Set DI/O Active State	99
10.4.82	~AASDBv	Set DI debounce mode	99

10.4.83 ~AARDB Readet DI debounce mode	99
Chapter 11 E5KDAQ.DLL API.....	100
11.1 Common Functions	100
11.2 Analog Functions	101
11.3 DIO Functions	101
11.4 E5K_SearchModules	102
11.5 E5K_OpenModuleUSB	102
11.6 E5K_OpenModuleIP.....	102
11.7 E5K_OpenModuleIPEX.....	103
11.8 E5K_OpenModuleCOM.....	103
11.9 E5K_CloseModules.....	104
11.10 E5K_GetDLLVersion	104
11.11 E5K_VerifyPassWord.....	104
11.12 E5K_ChangePassWord.....	105
11.13 E5K_GetLastErrorCode.....	105
11.14 E5K_SetRXTimeOutOption.....	106
11.15 E5K_StartAlarmEventIP.....	106
11.16 E5K_StartAlarmEventIPEX.....	106
11.17 E5K_StopAlarmEventIP.....	107
11.18 E5K_StartAlarmEventUSB.....	107
11.19 E5K_StopAlarmEventUSB.....	107
11.20 E5K_ReadAlarmEventData.....	108
11.21 E5K_StartStreamEvent.....	108
11.22 E5K_StartStreamEventEx.....	108
11.23 E5K_StopStreamEvent.....	109
11.24 E5K_ReadStreamEventData.....	109
11.25 E5K_ReadModuleConfig.....	109
11.26 E5K_SetModuleConfig.....	110
11.27 E5K_WriteModbusDiscrete.....	110
11.28 E5K_WriteModbusRegister.....	111
11.29 E5K_ReadModbusRegister.....	111
11.30 E5K_ReadModbusDiscrete.....	112
11.31 E5K_SendASCRequestAndWaitResponse.....	112
11.32 E5K_RecvASCII.....	113
11.33 E5K_SendASCII.....	113
11.34 E5K_SendHEXRequestAndWaitResponse.....	114
11.35 E5K_SendHEX.....	114
11.36 E5K_RecvHEX.....	115
11.37 E5K_CalculateCRC16.....	115
11.38 E5K_SetLEDControl.....	115

11.39	E5K_WriteDataToLED.....	116
11.40	E5K_FlashLED.....	116
11.41	E5K_IsValidIPAddress	116
11.42	E5K_IsIPInLocalSubnet.....	117
11.43	E5K_IsIPInLocalSubnetEx	117
11.44	E5K_GetLocalIP	117
11.45	E5K_TCPConnect	118
11.46	E5K_TCPConnectEx.....	118
11.47	E5K_TCPSendData.....	119
11.48	E5K_TCPRecvData.....	119
11.49	E5K_TCPPing	119
11.50	E5K_TCPDisconnect	120
11.51	E5K_TCPAIldisconnect	120
11.52	E5K_UDPConnect.....	120
11.53	E5K_UDPConnectEx	121
11.54	E5K_UDPSendData	121
11.55	E5K_UDPRecvData	121
11.56	E5K_UDPSendASCStr	122
11.57	E5K_UDPRecvASCStr.....	122
11.58	E5K_UDPDisconnect.....	122
11.59	E5K_UDPAIldisconnect.....	123
11.60	E5K_ReadAIChannelType	123
11.61	E5K_SetAIChannelType.....	123
11.62	E5K_SetSingleChannelColdJunctionOffset.....	124
11.63	E5K_ReadSingleChannelColdJunctionOffset.....	124
11.64	E5K_ReadMultiChannelColdJunctionOffset.....	124
11.65	E5K_SetMultiChannelColdJunctionOffset	125
11.66	E5K_ReadColdJunctionTemperature	125
11.67	E5K_ReadColdJunctionStatus	126
11.68	E5K_SetColdJunction	126
11.69	E5K_ReadAIChannelConfig	126
11.70	E5K_SetAIChannelConfig	127
11.71	E5K_ReadAIBurnOutStatus.....	127
11.72	E5K_ReadAIAlarmStatus	127
11.73	E5K_SetAIBurnOut.....	128
11.74	E5K_ReadAIBurnOut.....	128
11.75	E5K_SetAIModuleFilter	128
11.76	E5K_ReadAIModuleFilter	129
11.77	E5K_SetAIChannelEnable	129
11.78	E5K_ReadAIChannelEnable.....	129

11.79	E5K_ReadAINormalMultiChannel.....	130
11.80	E5K_ReadAIMaximumMultiChannel	130
11.81	E5K_ReadAIMinumumMultiChannel	131
11.82	E5K_ResetAIMaximum.....	131
11.83	E5K_ResetAIMinimum.....	132
11.84	E5K_ResetAIHighAlarm	132
11.85	E5K_ResetAILowAlarm	132
11.86	E5K_ReadAIChannelAverage	133
11.87	E5K_SetAIChannelAverage.....	133
11.88	E5K_SetDIChannelConfig.....	133
11.89	E5K_ReadDIChannelConfig	134
11.90	E5K_ReadDIStatus.....	134
11.91	E5K_ReadDILatch.....	134
11.92	E5K_ClearAIIDLatch	135
11.93	E5K_ClearSingleDICounter	135
11.94	E5K_ReadMultiDICounter	135
11.95	E5K_WriteDO	136
11.96	E5K_ReadDOStatus.....	136
11.97	E5K_SetDOSingleChannel	136
11.98	E5K_SetDOPulseWidth	137
11.99	E5K_ReadDOPulseWidth.....	137
11.100	E5K_StartDOPulse	138
11.101	E5K_StartMultipleDOPulse	138
11.102	E5K_StopDOPulse	138
11.103	E5K_ReadDOPulseCount.....	139
11.104	E5K_SetDOPowerOnValue.....	139
11.105	E5K_ReadDOPowerOnValue	139
11.106	E5K_ReadDIOActiveLevel	140
11.107	E5K_SetDIOActiveLevel.....	140
Chapter 12 E5KDAQ.DLL Error Code		141
Chapter 13 Event/Stream Interrupt structure		143
13.1	Event Interrupt Structure.....	143
13.2	Stream Interrupt Structure	143
Chapter 14 E5KDAQ ActiveX Control		144
14.1	Properties Of E5KDSAQ ActiveX Control	144
14.2	Methods of E5KDAQ ActiveX Control	145
14.3	Events of E5KDAQ ActiveX control.....	145
Chapter 15 EDAM 5000 Utility Overview		146
15.1	Main Menu	146
15.2	Communication Interface Settings	147

15.3	Tool Bar	148
15.4	Menu Bar	149
15.5	EDAM5000 module configuration	151
15.6	EDAM5060 Settings	152
15.6.1	Module settings tab	152
15.6.2	Digital input settings tab.....	153
15.6.3	Digital output settings tab	154
15.6.4	Test tab	155
15.7	EDAM5029 Settings	156
15.7.1	Module settings tab	156
15.7.2	Digital input settings tab.....	157
15.7.3	Digital output settings tab	158
15.7.4	Test tab	159
15.8	EDAM5028 Settings	160
15.8.1	Module settings tab	160
15.8.2	Digital input settings tab.....	161
15.8.3	Digital output settings tab	162
15.8.4	Test tab	163
15.9	EDAM-5019 Configuration	164
15.9.1	Module settings tab	164
15.9.2	Analog settings tab	165
15.9.3	Digital input settings tab.....	166
15.9.4	Digital output settings tab	167
15.9.5	Test tab	168
15.10	EDAM-5017 Configuration	170
15.10.1	Module settings tab	170
15.10.2	Analog settings tab	171
15.10.3	Digital input settings tab.....	172
15.10.4	Digital output settings tab	173
15.10.5	Test tab	174
15.11	EDAM-5015 Configuration	176
15.11.1	Module settings tab	176
15.11.2	Channel settings tab.....	177
15.11.3	Test tab	178
Chapter 16	Firmware Update.....	179
Chapter 17	Reload Default Settings	185
Chapter 18	Zero/Span Calibration	186
18.1	EDAM-5015 Calibration	186
18.2	EDAM-5017 Calibration	189
18.3	EDAM-5019 Calibration	192

Chapter 1 Major Features

1.1 Multi-Interface DA&C I/O Modules

EDAM-5000 is based on the popular Ethernet/USB/RS485/RS232 networking standards used today in most business environments.

EDAM-5000 series provides :

1. 10/100 Mbps Ethernet interfaces and supports Modbus/TCP protocol over TCP/IP for data connection.
2. USB 2.0 (high speed) interfaces and supports Modbus RTU /ASCII protocol for data connection.
3. RS485/232C interface and supports Modbus RTU /ASCII protocol for data connection.

With built-in Real Time OS (RTOS), The EDAM-5000 modules can connect to all communication interfaces simultaneously

1.2 Intelligent I/O Modules

Enhancing from traditional I/O modules, EDAM-5000 I/O modules have pre-built intelligent mathematic functions to empower the system capacity. The Digital Input modules provide Counter, Totalize functions; the Digital Output modules provide pulse output, delay output functions; the Analog Input modules provide the Max./Min./Average data calculation; the Analog Output modules provide the PID loop control function.

1.3 Mixed I/O In One Module To Fit All Applications

EDAM-5000 mixed I/O module design concept provides the most cost-effective I/O usage for application system. The most common used I/O type for single function unit are collected in ONE module. This design concept not only save I/O usage and spare modules cost but also speed up I/O relative operations. For small DA&C system or standalone control unit in a middle or large scale, EDAM-5000 mixed I/O design can easily fit application needs by one or two modules only. With additional embedded control modules, EDAM-5000 can easily create a localized, less complex, and more distributed I/O architecture.

1.4 Modbus/TCP and RTU Protocol Supported For Open Connectivity

EDAM-5000 modules support the popular industrial standard, Modbus/TCP and RTU protocol, to connect with Ethernet Controller or HMI/SCADA software built with Modbus/TCP or RTU driver.

1.5 Software Support

Based on the Modbus/TCP and RTU standard, the EDAM-5000 firmware is a built-in Modbus/TCP and RTU server. Therefore, Inlog provides the necessary DLL drivers and Windows Utility for users for client data for the EDAM-5000. Users can configure this DA&C system via Windows Utility; integrate with HMI software package via Modbus/TCP driver or Modbus/TCP OPC Server. Even more, you can use the DLL driver and ActiveX to develop your own applications.

1.6 Common Technical Specification Of EDAM-5000

- **Ethernet** : 10 BASE-T IEEE 802.3 100 BASE-TX IEEE 802.3u
 - Wiring : UTP, category 5 or greater
 - Bus Connection : RJ45 modular jack
 - Comm. Protocol : Modbus/TCP on TCP/IP and RTU on UDP/IP or RS485, ASCII commands
 - Data Transfer Rate : Up to 100 Mbps
- **USB** : USB 2.0
 - Wiring : USB cable
 - Bus Connection : USB type B connector
 - Comm. Protocol : RTU, ASCII commands
 - Data Transfer Rate : High speed
- **RS485/232C:**
 - Wiring : Twist pair for RS485 or Three wires cable for RS232C
 - Bus Connection : 2/3 pin terminals
 - Comm. Protocol : RTU, ASCII commands
 - Data Transfer Rate : 2400,4800,9600,19200,38400,57600,115200
- **Power** :
 - USB powered (if USB connection)
 - External power with unregulated 10 to 30VDC
 - Over-voltage protection and power reversal
- **I/O Module Input Isolation : 3000 V DC**
- **Status Indicator : Power, Communication (Ethernet,USB,RS485/232)**
- **Case : ABS with captive mounting hardware**
- **Plug-in Screw Terminal Block : Accepts 0.5 mm 2 to 2.5 mm 2 , 1 - #12 or 2 - #14 to #22 AWG**
- **Operating Temperature : - 10 to 70° C (14 to 158° F)**
- **Storage Temperature : - 25 to 85° C (-13 to 185° F)**
- **Humidity : 5 to 95%, non-condensing**
- **Atmosphere : No corrosive gases**

NOTE : Equipment will operate below 30% humidity. However, static electricity problems occur much more frequently at lower humidity levels. Make sure you take adequate precautions when you touch the equipment. Consider using ground straps, anti-static floor coverings, etc. if you use the equipment in low humidity environments.

1.7 Dimensions

The following diagrams show the dimensions of the EDAM-5000 I/O module in millimeters.

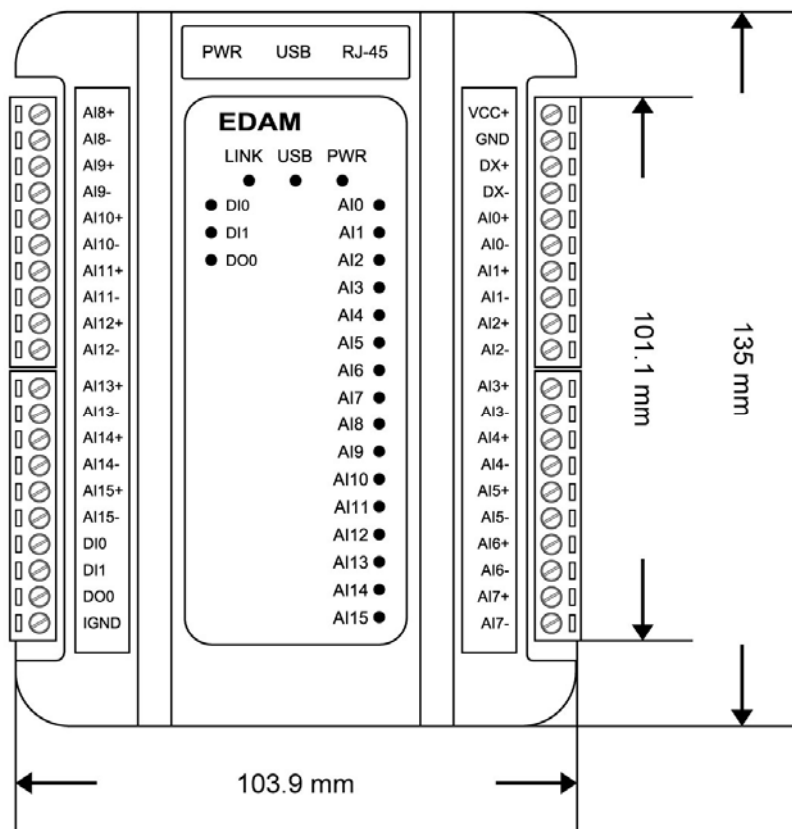

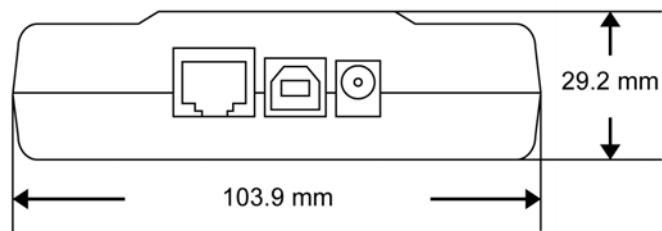
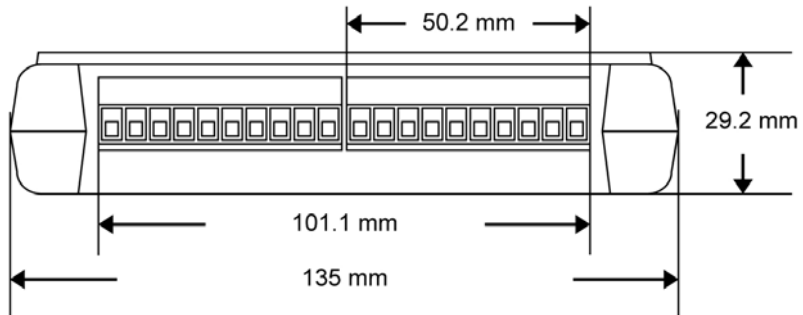
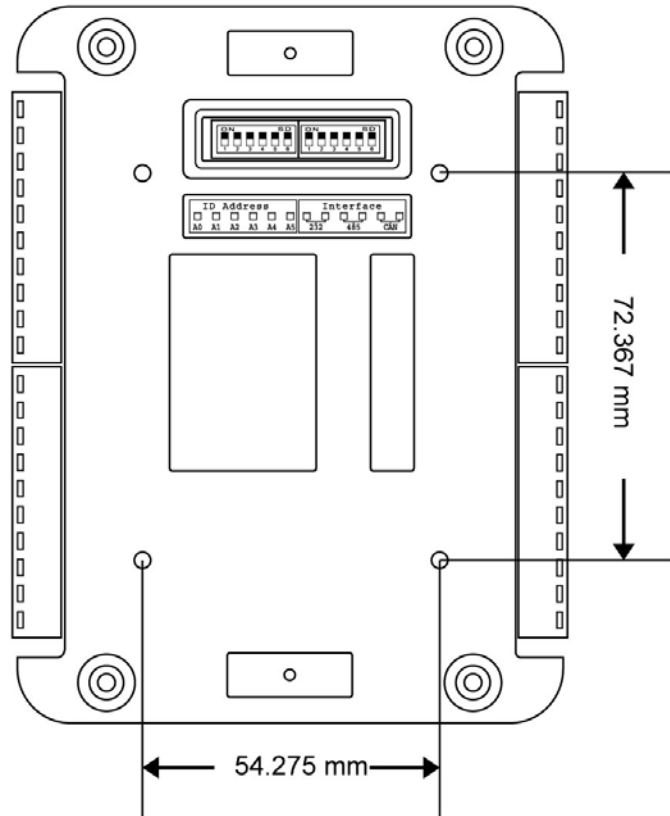

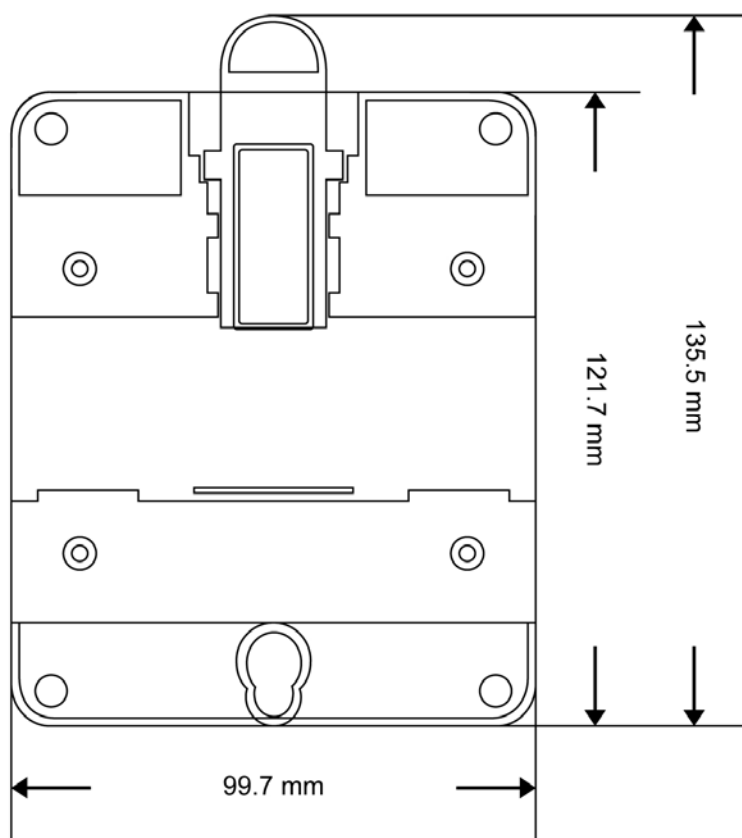

1.8 System Requirements

- IBM PC compatible computer with 486 CPU (Pentium is recommended)
- Microsoft 95/98/2000/NT 4.0 (SP3 or SP4)/XP or higher versions
- At least 32 MB RAM
- 20 MB of hard disk space available
- VGA color monitor
- 2x or higher speed CD-ROM
- Mouse or other pointing devices
- 10 or 100 Mbps Ethernet Card
- 10 or 100 Mbps Ethernet Hub (at least 2 ports)
- USB 2.0 hub with output current at least 400mA(if powered by USB hub)
- Two Ethernet Cable with RJ-45 connector
- Power supply for EDAM-5000 (+10 to +30 V unregulated), if no USB connection

1.9 I/O Modules Wiring

The system uses a plug-in screw terminal block for the interface between I/O modules and field devices. The following information must be considered when connecting electrical devices to I/O modules.

- The terminal block accepts wires from 0.5 mm to 2.5 mm.
- Always use a continuous length of wire. Do not combine wires to make them longer.
- Use the shortest possible wire length.
- Use wire trays for routing where possible.
- Avoid running wires near high-energy wiring.
- Avoid running input wiring in close proximity to output wiring where possible.
- Avoid creating sharp bends in the wires.

Chapter 2 Specifications

2.1 EDAM-5015 Specifications

The EDAM-5015 is a 16-bit, 12-channel RTD input module that provides programmable input ranges on all channels. It accepts Various RTD inputs (Type PT100, PT1000, Balco 500, NI604, NI1000) and provides data to the host computer.

- Analog Input
 - Effective Resolution: 16-bit
 - Channels : 12
 - Input Type : PT100, PT1000, Balco 500, NI RTD
 - Input Range : PT100 Type: -50 ~ 150°C/0 ~ 100°C, 0 ~ 200°C, 0 ~ 400°C, -200 ~ 200°C
PT1000 Type: -40 ~ 160°C
Balco 500 Type: -30 ~ 120°C
Ni604 Type: -80 ~ 100°C
Ni1000 Type: -0 ~ 100°C
- Sampling Rate : 10 samples/sec
- Input Impedance : 10 M Ω
- Accuracy : $\pm 0.15\%$ or better
- Zero Drift : $\pm 20 \mu\text{V}/^\circ\text{C}$
- Span Drift : 25 ppm/ $^\circ\text{C}$
- Built-in Watchdog Timer
- Power Requirements : USB powered (400mA max.) or external unregulated +10 ~ +30 VDC
- Power Consumption : 1.5 W/Typical, 2W/max

2.2 EDAM-5017 Specifications

The EDAM-5017 is a 16-bit, 16-channel Analog input module that provides programmable input ranges on all channels.

- Analog Input
 - Effective Resolution : 16-bit
 - Channels : 16
 - Input Type : Voltage, Current
 - Input Range : $\pm 10V$, $\pm 5V$, $\pm 2.5V$, $\pm 1V$, $\pm 500mV$, $\pm 15mV$, $0\sim 20mA$, $4\sim 20mA$
 - Sampling Rate : 10 samples/sec.
 - Input Impedance : 10 M Ω
 - Accuracy : $\pm 0.15\%$ or better
 - Zero Drift : $\pm 20 \mu V/ ^\circ C$
 - Span Drift : 25 ppm/ $^\circ C$
- Digital Input
 - Input Channel : 2 channels
 - Input Type : Voltage (logic 0 for $0 < V_{in} < 3V_{dc}$, logic 1 for $5V < V_{in} < 24V_{dc}$) or Switch On/Off
 - Isolation Voltage : 2000 V
- Digital Output
 - Output Channel : 1 channel
 - Output Type : Open Collect to 30Vdc/3A(max)
 - Isolation Voltage : 2000 V
- Built-in Watchdog Timer
- Power Requirements : USB powered (400mA max.) or external unregulated +10 ~ +30 VDC
- Power Consumption : 1.5 W/Typical, 2W/max

2.3 EDAM-5019 Specifications

The EDAM-5019 is a 16-bit, 16-channel Thermocouple input module that provides programmable input ranges on all channels. It accepts Various Thermocouple inputs (Type J, K, T, E, R, S, B) and provides data to the host computer in engineering units (°C). In order to satisfy various temperature requirements in one module, each analog channel is allowed to configure an individual range for several applications.

- Analog Input
 - Effective Resolution : 16-bit
 - Channels : 16
 - Input Type : J, K, T, E, R, S, B
 - Input Range : J Type : 0 ~ 760 °C
K Type : 0 ~ 1370 °C
T Type : -100 ~ 400 °C
E Type : 0 ~ 1000 °C
R Type : 500 ~ 1750 °C
S Type : 500 ~ 1750 °C
B Type : 500 ~ 1800 °C
 - Sampling Rate : 10 samples/sec, 20 samples/sec, 50 samples/sec.
 - Input Impedance : 10 MΩ
 - Accuracy : ±0.15% or better
 - Zero Drift : ±20 μV/ °C
 - Span Drift : ±25 ppm/ °C
- Digital Input
 - Input Channel : 2 channels
 - Input Type : Voltage (logic 0 for 0<Vin < 3Vdc , logic 1 for 5V<Vin < 24Vdc) or Switch On/Off
 - Isolation Voltage : 2000 VDC
- Digital Output
 - Output Channel : 1 channels
 - Output Type : Open Collect to 30Vdc/3A(max)
 - Isolation Voltage : 2000 VDC
- Built-in Watchdog Timer
- Power Requirements : USB powered (400mA max.) or external unregulated +10 ~ +30 VDC
- Power Consumption : 1.5 W/Typical, 2W/max

2.4 EDAM-5028 Specifications

The EDAM-5028 is a 8-channels MOSEFT output and 24-channels input module that provides programmable I/O ranges on all channels. It accepts Various Digital inputs/MOSFET outputs and provides data to the host computer.

- Digital Input
 - Channels : 24 channels
 - Input Type : Voltage (logic 0 for 3Vdc maximum, logic 1 for 5Vdc minimums) or Switch On/Off
 - Isolation Voltage : 2000 V
- Digital Output
 - Output Channel : 8 channels
 - Output Type : Source Output up to 30Vdc/3A(max)
 - Isolation Voltage : 2000 V
- Built-in Watchdog Timer
- Power Requirements : USB powered (400mA max.) or external unregulated +10 ~ +30 VDC
- Power Consumption : 1.5 W/Typical, 2W/max

2.5 EDAM-5029 Specifications

The EDAM-5029 is a 16-channels MOSEFT output and 16-channels digital input module that provides programmable I/O ranges on all channels. It accepts Various Digital inputs/MOSFET outputs and provides data to the host computer.

- Digital Input
 - Channels : 16 channels
 - Input Type : Voltage (logic 0 for 3Vdc maximum, logic 1 for 5Vdc minimums) or Switch On/Off
 - Isolation Voltage : 2000 V
- Digital Output
 - Output Channel : 16 channels
 - Output Type : Source Output up to 30Vdc/3A(max)
 - Isolation Voltage : 2000 V
- Built-in Watchdog Timer
- Power Requirements : USB powered (400mA max.) or external unregulated +10 ~ +30 VDC
- Power Consumption : 1.5 W/Typical, 2W/max

2.6 EDAM-5060 Specifications

The EDAM-5060 is a 10-channels Relay and 12-channels digital input module that provides programmable I/O ranges on all channels. It accepts Various Digital inputs/Relay outputs and provides data to the host computer.

- Digital Input
 - Channels : 12 channels
 - Input Type : Voltage (logic 0 for 3Vdc maximum, logic 1 for 5Vdc minimums) or Switch On/Off
 - Isolation Voltage : 2000 V
- Relay Output
 - Relay Channel : 10 Relay output
 - Relay Type : Form-A (DPDT)
 - Contact Rating : AC 3A/125V, DC 3A/30V, 3A/110V
 - Breakdown Voltage : OPEN contacts : 1000VAC, Contacts and coil : 1000VAC
 - FCC Surge Voltage : Contacts and coil : 1500V
 - Insulation Resistance : 100M ohm (at 500VDC)
 - Operate Time : 6ms
 - Release Time : 4ms
 - Min. Operations : 500000 times(At 1A/30VDC)
- Built-in Watchdog Timer
- Power Requirements : USB powered (400mA max.) or external unregulated +10 ~ +30 VDC
- Power Consumption : 1.5 W/Typical, 2W/max

Chapter 3 Connector/Pin Assignment

3.1 EDAM-5015 Front Side Connectors

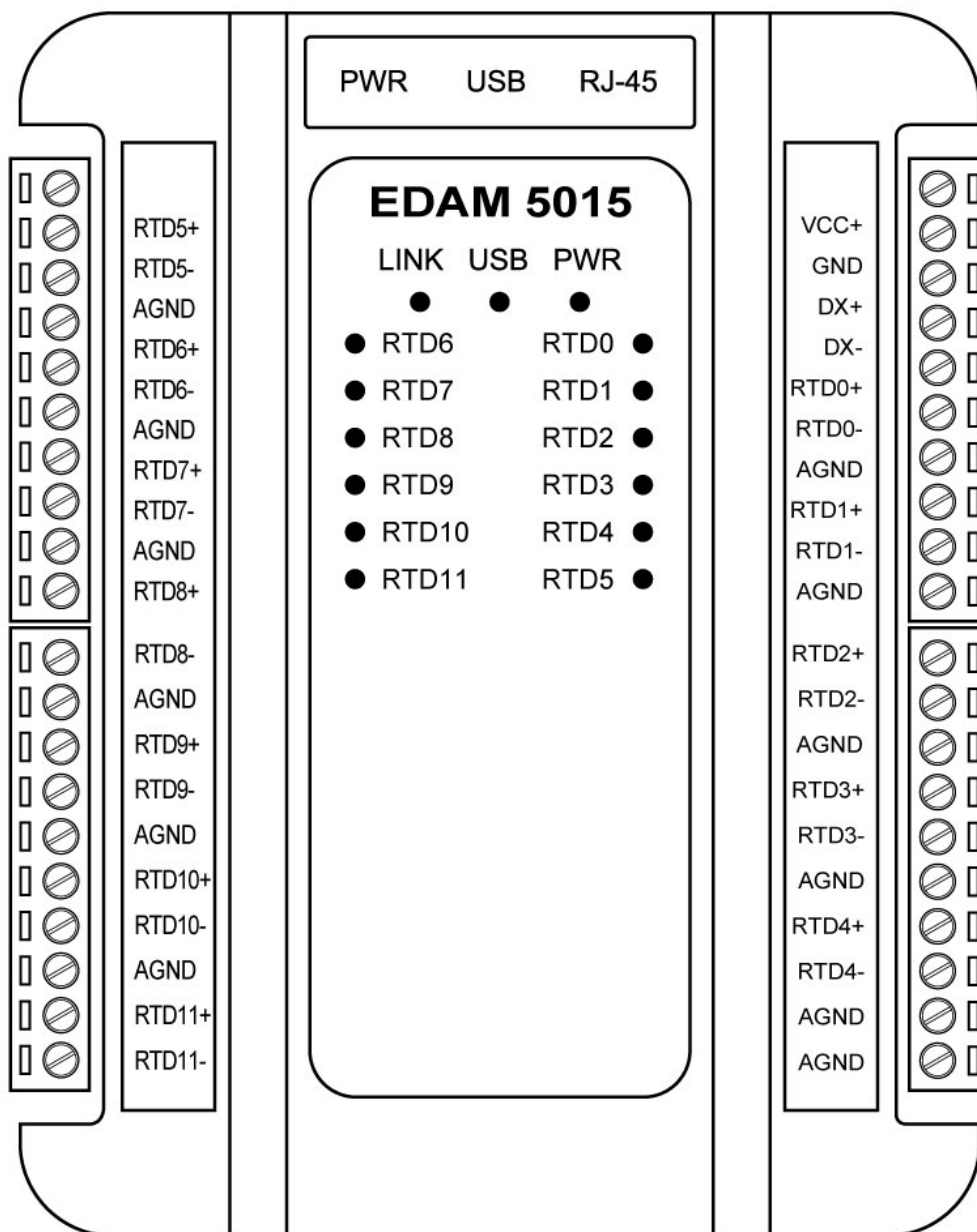

Connector	Description
RJ-45	Ethernet Connector
PWR	External Power Connector
VCC+	External Power 10<Vdc<30
GND	Power Ground
DX+	Data+ (for RS-485) , TX (for RS-232C)
DX-	Data- (for RS-485) , RX (for RS-232C)
RTD0+, RTD0-	RTD Input Channel 0
AGND	RTD Common 0
RTD1+, RTD1-	RTD Input Channel 1
AGND	RTD Common 1
RTD2+, RTD2-	RTD Input Channel 2
AGND	RTD Common 2
RTD3+, RTD3-	RTD Input Channel 3
AGND	RTD Common 3
RTD4+, RTD4-	RTD Input Channel 4
AGND	RTD Common 4
RTD5+, RTD5-	RTD Input Channel 5
AGND	RTD Common 5
RTD6+, RTD6-	RTD Input Channel 6
AGND	RTD Common 6
RTD7+, RTD7-	RTD Input Channel 7
AGND	RTD Common 7
RTD8+, RTD8-	RTD Input Channel 8
AGND	RTD Common 8
RTD9+, RTD9-	RTD Input Channel 9
AGND	RTD Common 9
RTD10+, RTD10-	RTD Input Channel 10
AGND	RTD Common 10/11
RTD11+, RTD11-	RTD Common 11

3.2 EDAM-5017 Front Side Connectors

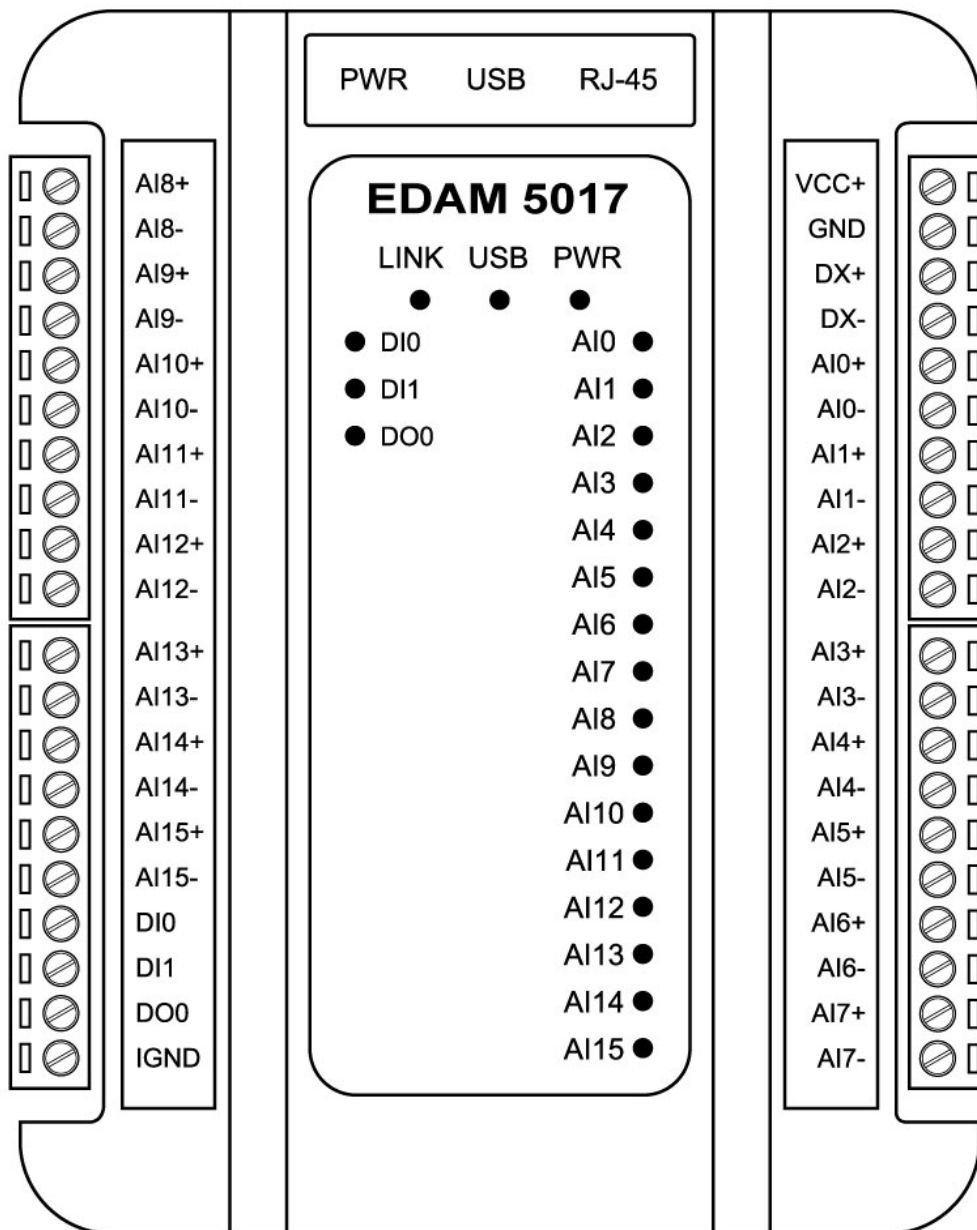

Connector	Description
RJ-45	Ethernet Connector
PWR	External Power Connector
VCC+	External Power 10<Vdc<30
GND	Power Ground
DX+	Data+ (for RS-485) , TX (for RS-232C)
DX-	Data- (for RS-485) , RX (for RS-232C)
AI0+,AI0-	Analog Input Channel 0
AI1+,AI1-	Analog Input Channel 10
AI2+,AI2-	Analog Input Channel 2
AI3+,AI3-	Analog Input Channel 3
AI4+,AI4-	Analog Input Channel 4
AI5+,AI5-	Analog Input Channel 5
AI6+,AI6-	Analog Input Channel 6
AI7+,AI7-	Analog Input Channel 7
AI8+,AI8-	Analog Input Channel 8
AI9+,AI9-	Analog Input Channel 9
AI10+,AI10-	Analog Input Channel 10
AI11+,AI11-	Analog Input Channel 11
AI12+,AI12-	Analog Input Channel 12
AI13+,AI13-	Analog Input Channel 13
AI14+,AI14-	Analog Input Channel 14
AI15+,AI15-	Analog Input Channel 15
DI0	Digital Input Channel 0
DI1	Digital Input Channel 1
DO0	Digital Output Channel 0
IGND	Isolated Digital GND

3.3 EDAM-5019 Front Side Connectors

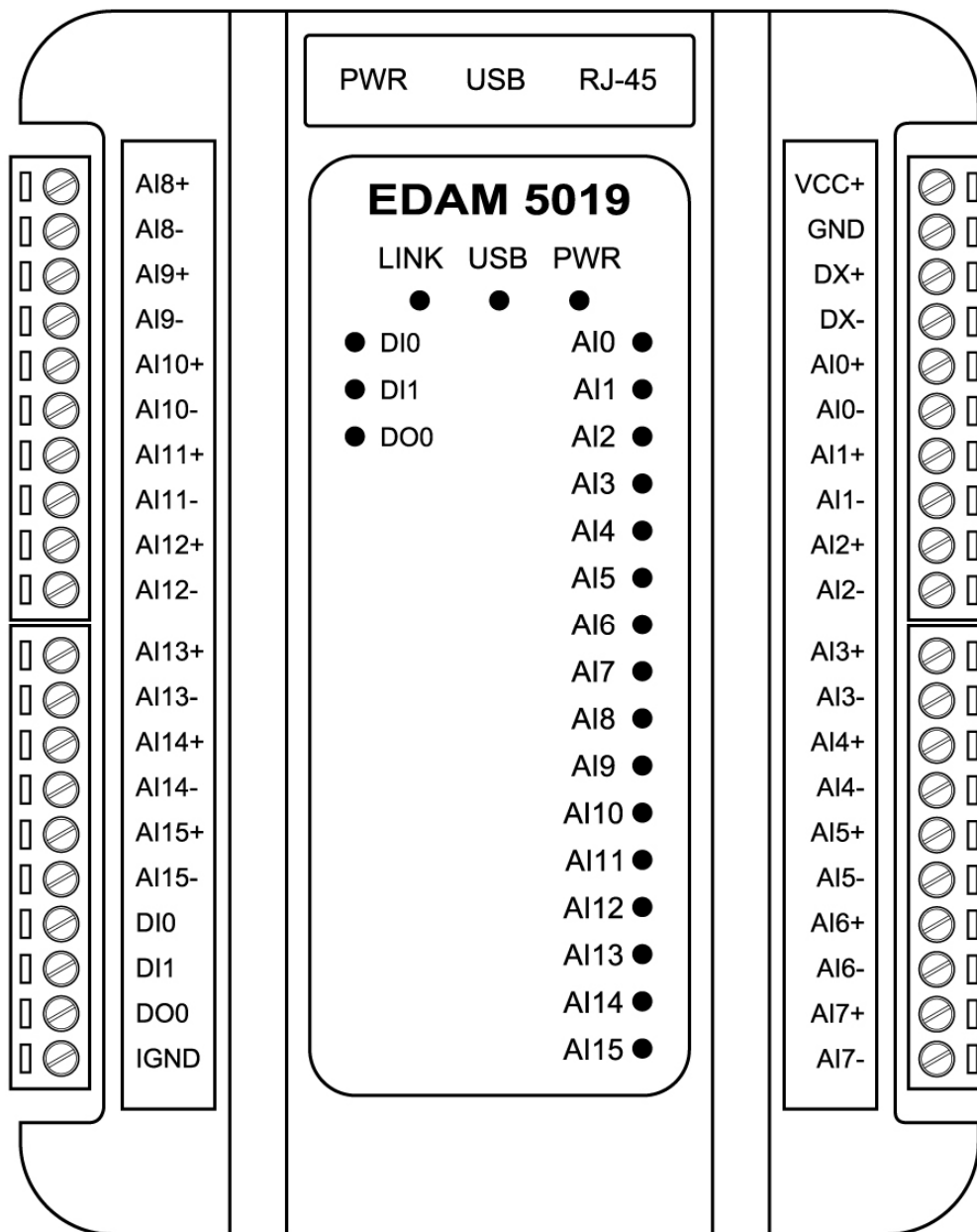

Connector	Description
RJ-45	Ethernet Connector
PWR	External Power Connector
VCC+	External Power 10<Vdc<30
GND	Power Ground
DX+	Data+ (for RS-485) , TX (for RS-232C)
DX-	Data- (for RS-485) , RX (for RS-232C)
AI0+,AI0-	Analog Input Channel 0
AI1+,AI1-	Analog Input Channel 10
AI2+,AI2-	Analog Input Channel 2
AI3+,AI3-	Analog Input Channel 3
AI4+,AI4-	Analog Input Channel 4
AI5+,AI5-	Analog Input Channel 5
AI6+,AI6-	Analog Input Channel 6
AI7+,AI7-	Analog Input Channel 7
AI8+,AI8-	Analog Input Channel 8
AI9+,AI9-	Analog Input Channel 9
AI10+,AI10-	Analog Input Channel 10
AI11+,AI11-	Analog Input Channel 11
AI12+,AI12-	Analog Input Channel 12
AI13+,AI13-	Analog Input Channel 13
AI14+,AI14-	Analog Input Channel 14
AI15+,AI15-	Analog Input Channel 15
DI0	Digital Input Channel 0
DI1	Digital Input Channel 1
DO0	Digital Output Channel 0
IGND	Isolated Digital GND

3.4 EDAM-5028 Front Side Connectors

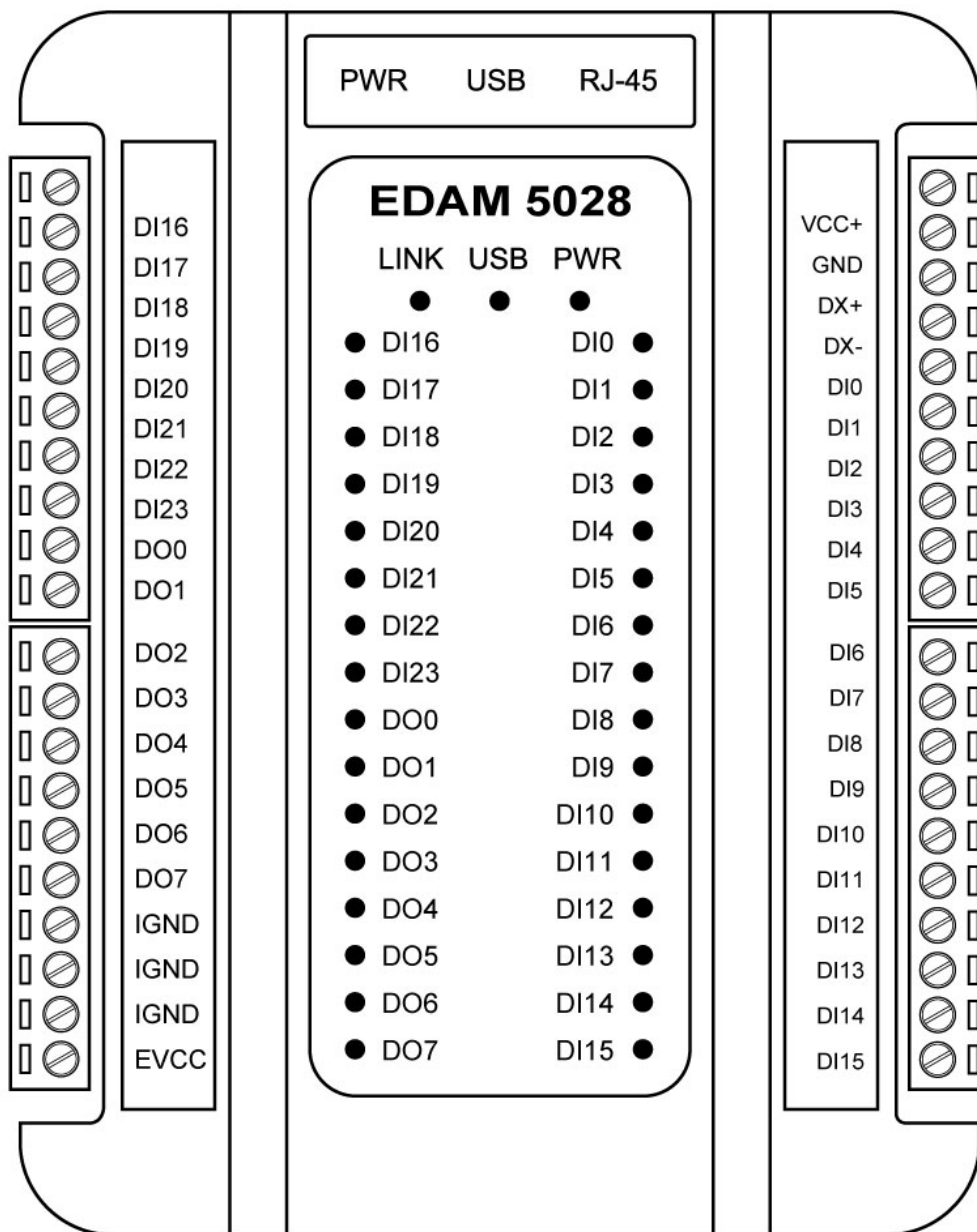

Connector	Description
RJ-45	Ethernet Connector
PWR	External Power Connector
VCC+	External Power 10<Vdc<30
GND	Power Ground
DX+	Data+ (for RS-485) , TX (for RS-232C)
DX-	Data- (for RS-485) , RX (for RS-232C)
DI0	Digital Input Channel 0
DI1	Digital Input Channel 1
DI2	Digital Input Channel 2
DI3	Digital Input Channel 3
DI4	Digital Input Channel 4
DI5	Digital Input Channel 5
DI6	Digital Input Channel 6
DI7	Digital Input Channel 7
DI8	Digital Input Channel 8
DI9	Digital Input Channel 9
DI10	Digital Input Channel 10
DI11	Digital Input Channel 11
DI12	Digital Input Channel 12
DI13	Digital Input Channel 13
DI14	Digital Input Channel 14
DI15	Digital Input Channel 15
DI16	Digital Input Channel 16
DI17	Digital Input Channel 17
DI18	Digital Input Channel 18
DI19	Digital Input Channel 19
DI20	Digital Input Channel 20
DI21	Digital Input Channel 21
DI22	Digital Input Channel 22
DI23	Digital Input Channel 23
DO0	Digital Output Channel 0
DO1	Digital Output Channel 1
DO2	Digital Output Channel 2
DO3	Digital Output Channel 3
DO4	Digital Output Channel 4
DO5	Digital Output Channel 5
DO6	Digital Output Channel 6
DO7	Digital Output Channel 7
IGND	Isolated Digital GND
IGND	Isolated Digital GND
IGND	Isolated Digital GND
EVCC	External DO Voltage Input (see 4.4)

3.5 EDAM-5029 Front Side Connectors

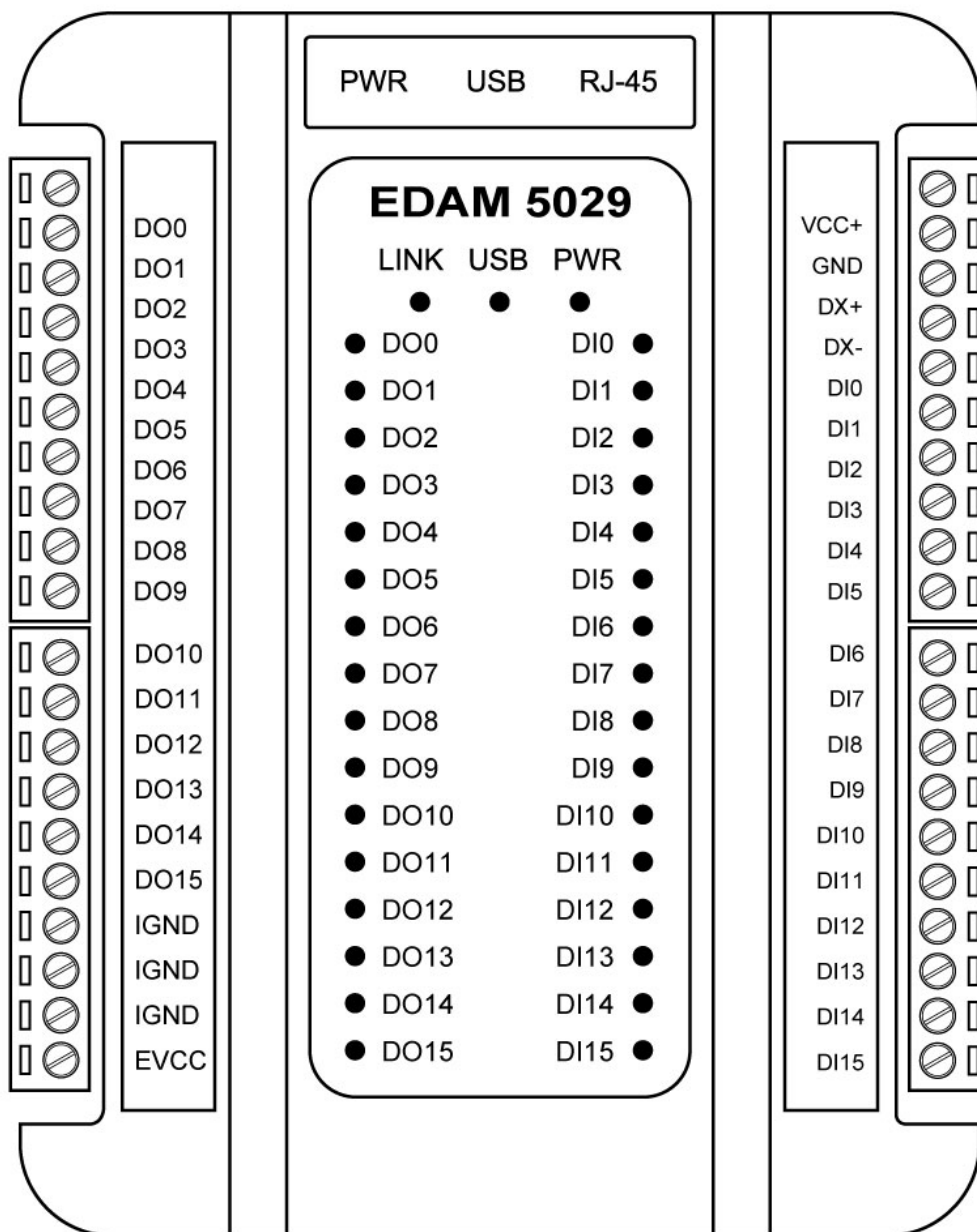

Connector	Description
RJ-45	Ethernet Connector
PWR	External Power Connector
VCC+	External Power 10<Vdc<30
GND	Power Ground
DX+	Data+ (for RS-485) , TX (for RS-232C)
DX-	Data- (for RS-485) , RX (for RS-232C)
DI0	Digital Input Channel 0
DI1	Digital Input Channel 1
DI2	Digital Input Channel 2
DI3	Digital Input Channel 3
DI4	Digital Input Channel 4
DI5	Digital Input Channel 5
DI6	Digital Input Channel 6
DI7	Digital Input Channel 7
DI8	Digital Input Channel 8
DI9	Digital Input Channel 9
DI10	Digital Input Channel 10
DI11	Digital Input Channel 11
DI12	Digital Input Channel 12
DI13	Digital Input Channel 13
DI14	Digital Input Channel 14
DI15	Digital Input Channel 15
DO0	Digital Output Channel 0
DO1	Digital Output Channel 1
DO2	Digital Output Channel 2
DO3	Digital Output Channel 3
DO4	Digital Output Channel 4
DO5	Digital Output Channel 5
DO6	Digital Output Channel 6
DO7	Digital Output Channel 7
DO8	Digital Output Channel 8
DO9	Digital Output Channel 9
DO10	Digital Output Channel 10
DO11	Digital Output Channel 11
DO12	Digital Output Channel 12
DO13	Digital Output Channel 13
DO14	Digital Output Channel 14
DO15	Digital Output Channel 15
IGND	Isolated Digital GND
IGND	Isolated Digital GND
IGND	Isolated Digital GND
EVCC	External DO Voltage Input (see 4.5)

3.6 EDAM-5060 Front Side Connectors

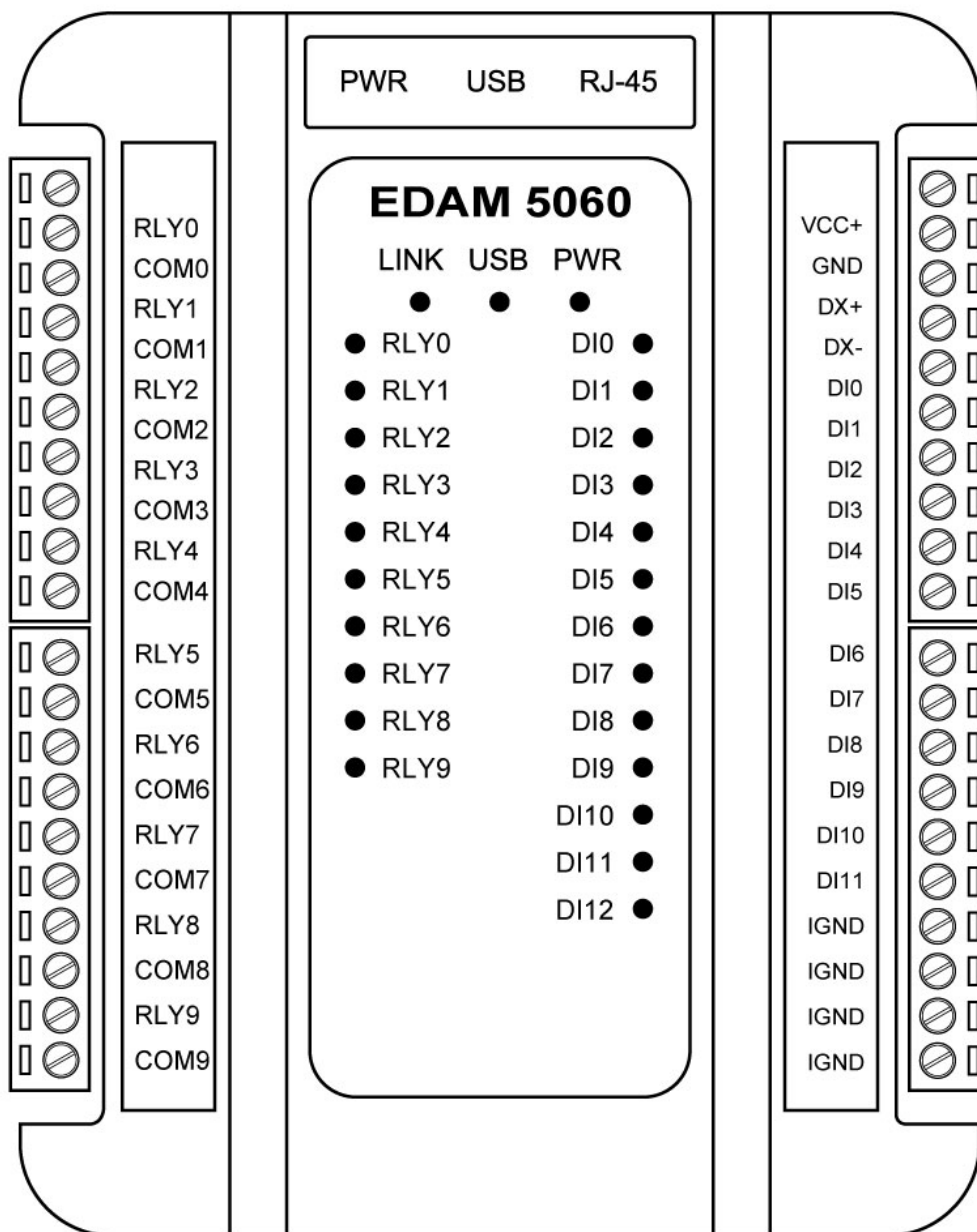

Connector	Description
USB	USB Connector
RJ-45	Ethernet Connector
PWR	External Power Adapter
VCC+	External Power 10<Vdc<30
GND	Power Ground
DX+	Data+ (for RS-485) , TX (for RS-232C)
DX-	Data- (for RS-485) , RX (for RS-232C)
DI0	Digital Output Channel 0
DI1	Digital Output Channel 1
DI2	Digital Output Channel 2
DI3	Digital Output Channel 3
DI4	Digital Output Channel 4
DI5	Digital Output Channel 5
DI6	Digital Output Channel 6
DI7	Digital Output Channel 7
DI8	Digital Output Channel 8
DI9	Digital Output Channel 9
DI10	Digital Output Channel 10
DI11	Digital Output Channel 11
IGND	Common GND For Digital Input
IGND	Common GND For Digital Input
IGND	Common GND For Digital Input
IGND	Common GND For Digital Input
RLY0	Relay Output Channel 0 (normal open)
COM0	Common 0
RLY1	Relay Output Channel 1 (normal open)
COM1	Common 1
RLY2	Relay Output Channel 2 (normal open)
COM2	Common 2
RLY3	Relay output Channel 3 (normal open)
COM3	Common 3
RLY4	Relay Output Channel 4 (normal open)
COM4	Common 4
RLY5	Relay Output Channel 5 (normal open)
COM5	Common 5
RLY6	Relay Output Channel 6 (normal open)
COM6	Common 6
RLY7	Relay Output Channel 7 (normal open)
COM7	Common 7
RLY8	Relay Output Channel 8 (normal open)
COM8	Common 8
RLY9	Relay Output Channel 9 (normal open)
COM9	Common 9

3.7 EDAM-5000 Rear Side Connectors

There are two 6-pin DIP switches labeled as **ID address** and **Interface**.

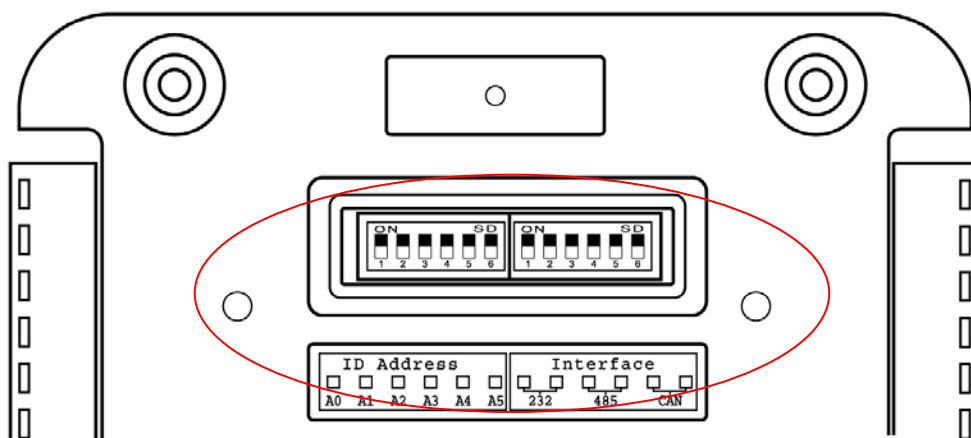

3.7.1 ID Address Switch Is Used For Setting ID Address Of Module

“ON” =logic 1, “OFF”=logic 0



Where

- A0=bit 0 of ID address
- A1=bit 1 of ID address
- A2=bit 2 of ID address
- A3=bit 3 of ID address
- A4=bit 4 of ID address
- A5=bit 5 of ID address

Example1 : Assume A0=“ON”, A1, A2, A3=“OFF” and A4, A5=“ON”
Then the ID address= A5-A4-A3-A2-A1-A0=110001=31(hex) =49(dec)

Example2 : Assume A0=“OFF”, A1, A2, A3=“ON” and A4, A5=“OFF”
Then the ID address= A5-A4-A3-A2-A1-A0=001110=0E (hex)=14(dec)

3.7.2 Communication Interfaces (RS485 ,RS232 ,or CAN bus)

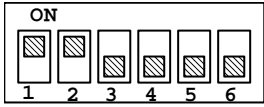
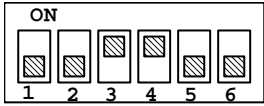
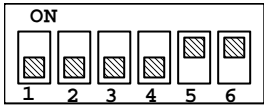
Switch Pin Setting	DX+	DX-	GND
	TX signal of RS232	RX signal of RS232	GND of RS232
	Data+ of RS485	Data- of RS485	
	DX+ of CAN BUS	DX- of CAN BUS	

Note : CAN BUS function (Option)

3.7.3 EDAM-5000 Reset Switch And CJC Sensor

There are a reset switch (Reset) and temperature sensor (CJC) on the button side of the module. The reset switch is available for all modules. The users could push this switch to reboot the module. The Temperature sensor (cold junction compensation CJC) is available for EDAM-5019 only.

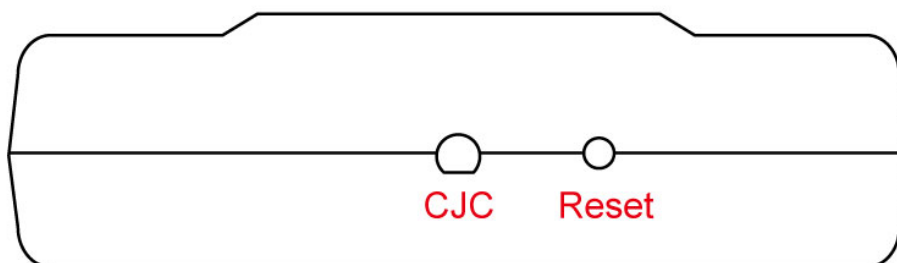

3.7.4 EDAM-5015 Analog/Digital I/O Block Diagram

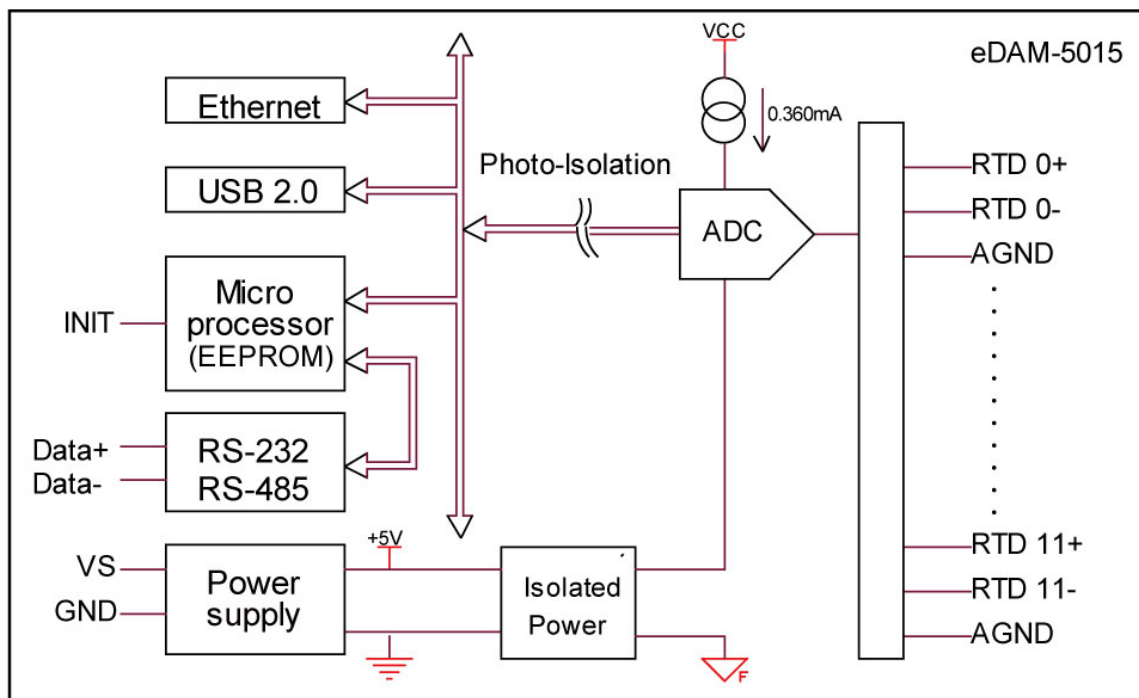

3.7.5 EDAM-5017 Analog/Digital I/O Block Diagram

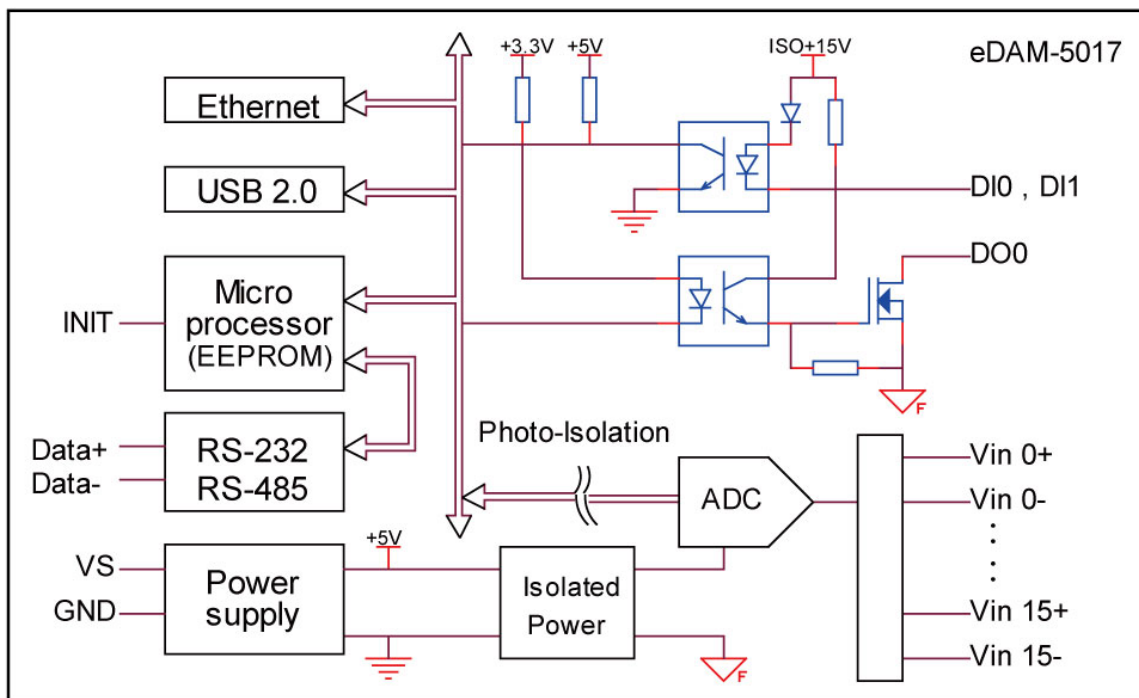

3.7.6 EDAM-5019 Analog/Digital I/O Block Diagram

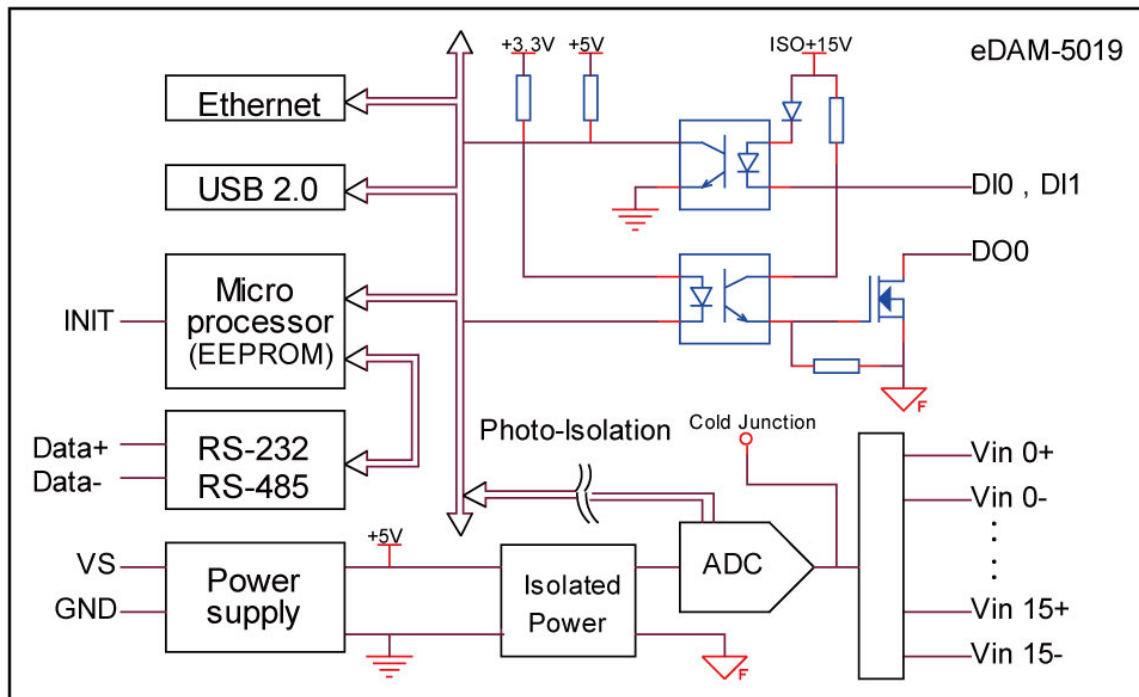

3.7.7 EDAM-5028 Analog/Digital I/O Block Diagram

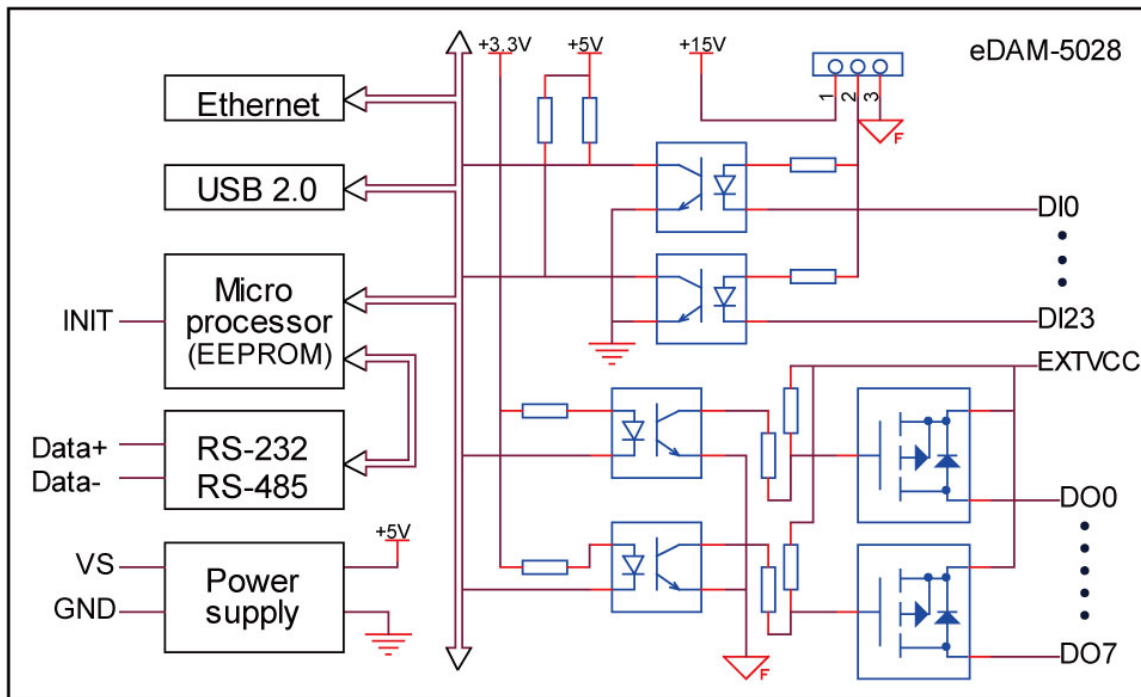

3.7.8 EDAM-5029 Analog/Digital I/O Block Diagram

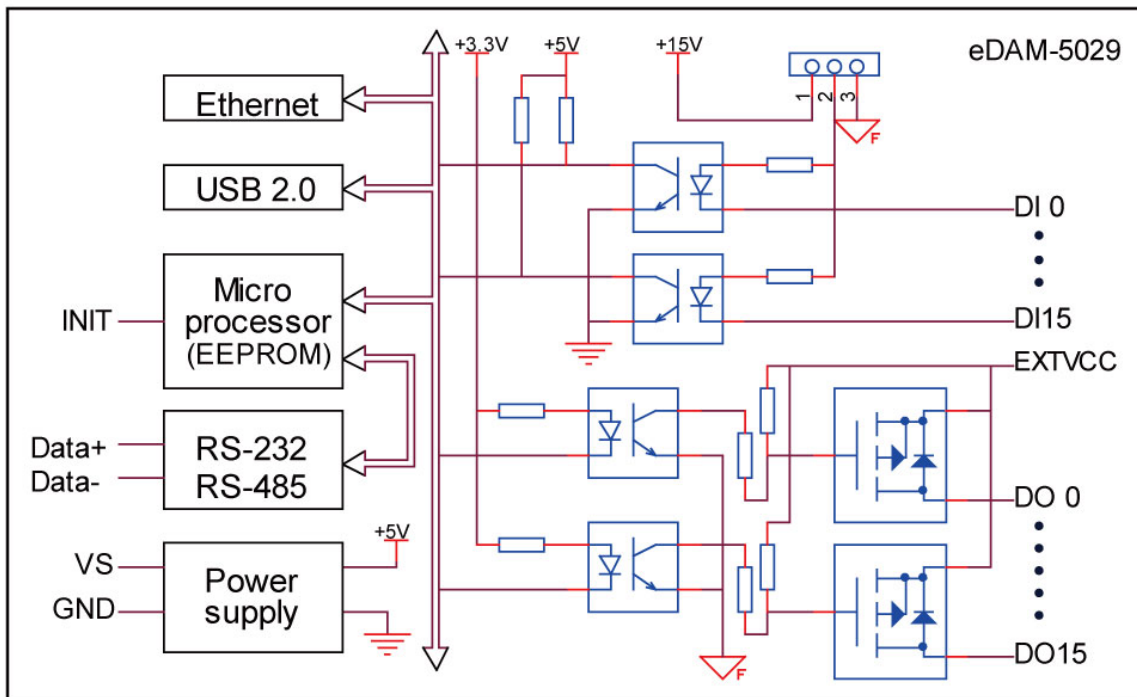

3.7.9 EDAM-5060 Analog/Digital I/O Block Diagram

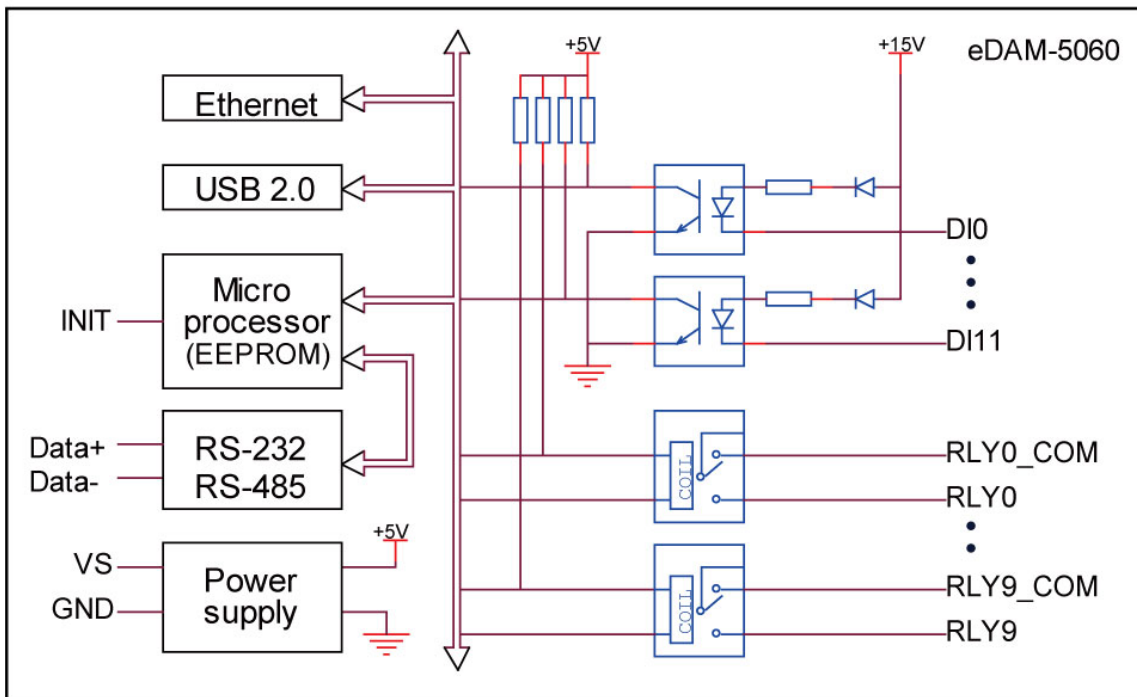

Chapter 4 Application Wiring

4.1 EDAM-5015 Wiring

■ Interface Connection

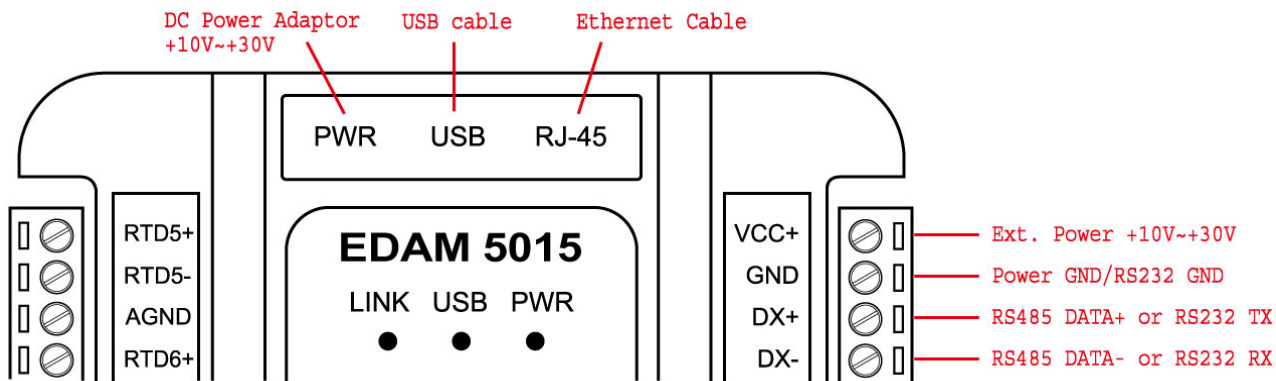

■ Analog Input Wiring

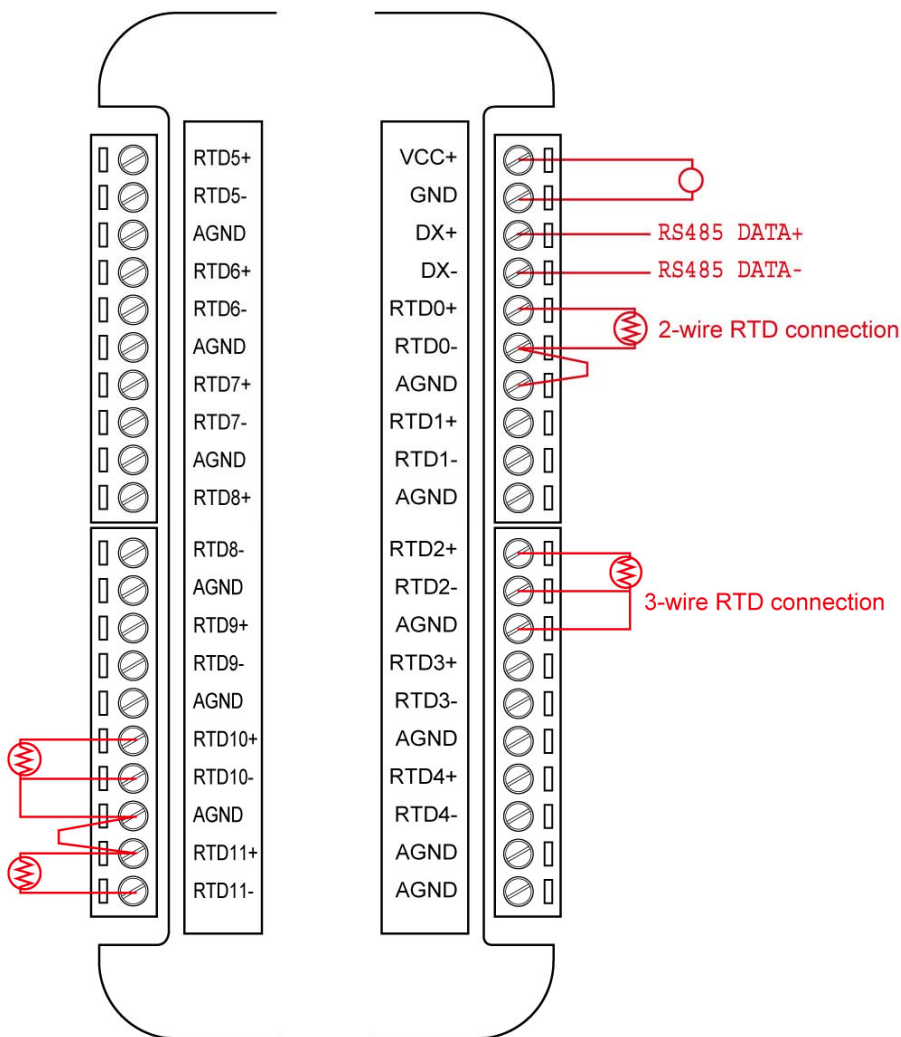

4.2 EDAM-5017 wiring

Interface Connection

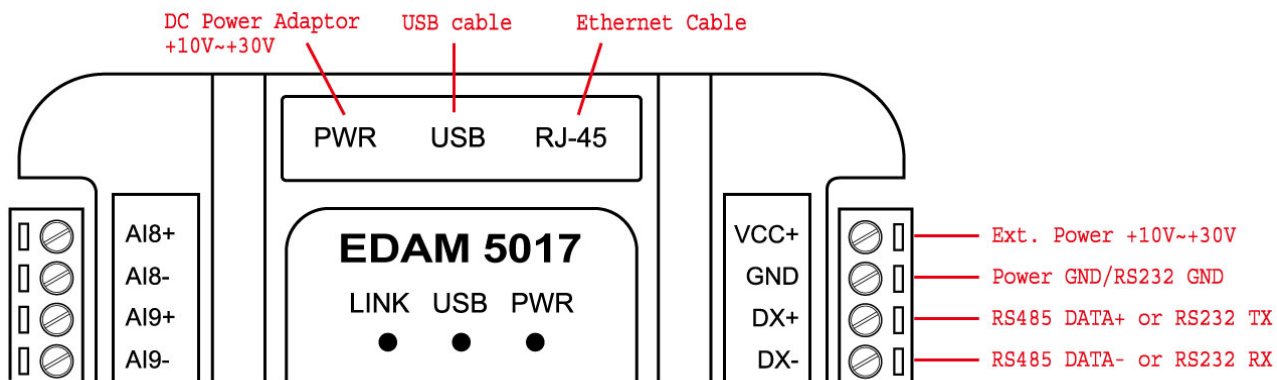

Analog Input Wiring

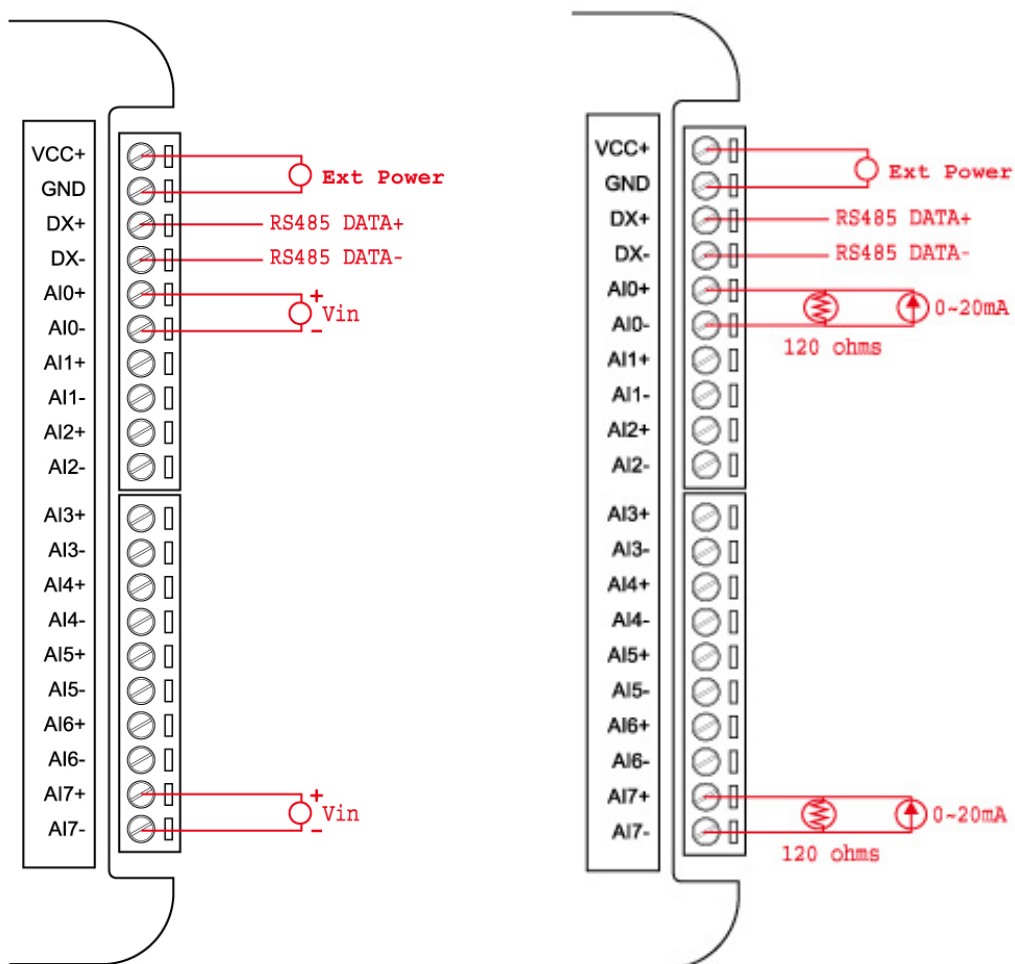

■ Digital Input Wiring

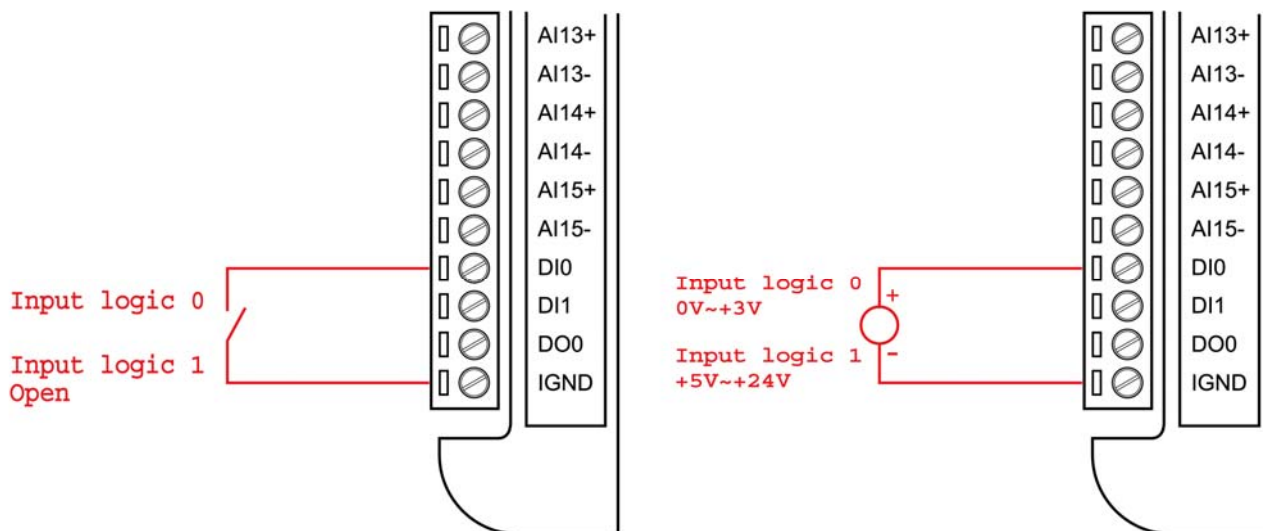

■ Digital Output Wiring

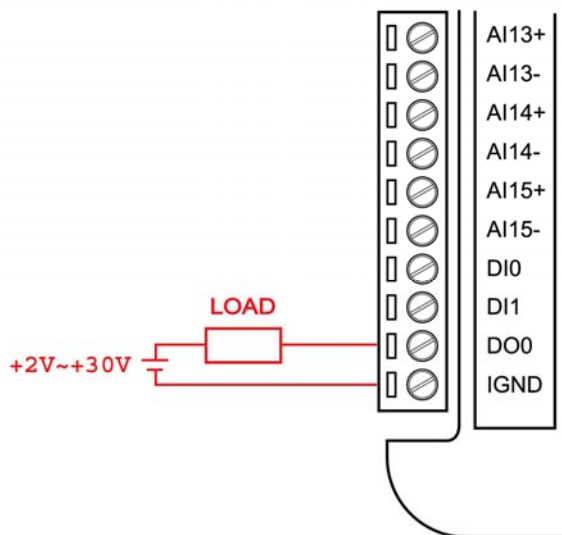

4.3 EDAM-5019 Wiring

■ Interface Connection

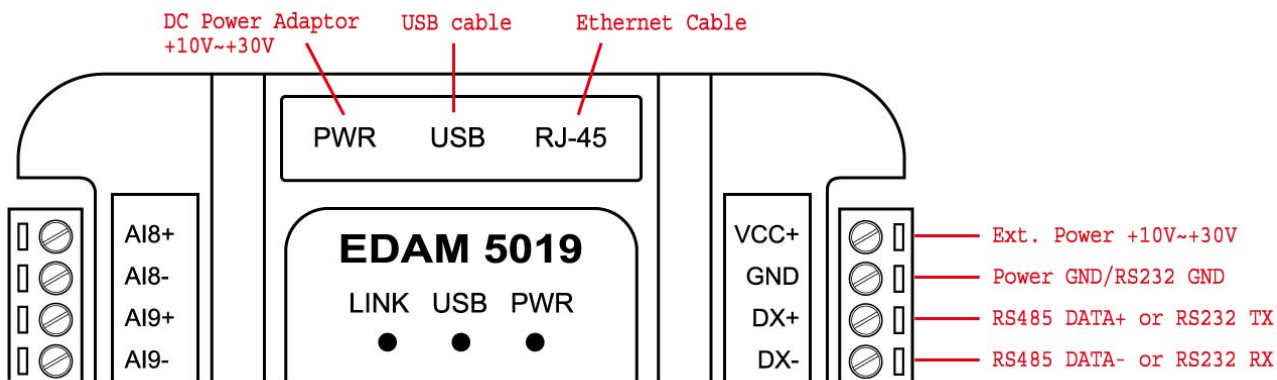

The function of DX+/DX- pins are depended on the Interface switch settings (see page 27)

■ Analog Input Wiring

Where AI_n+ and AI_n- represent AI input channel n

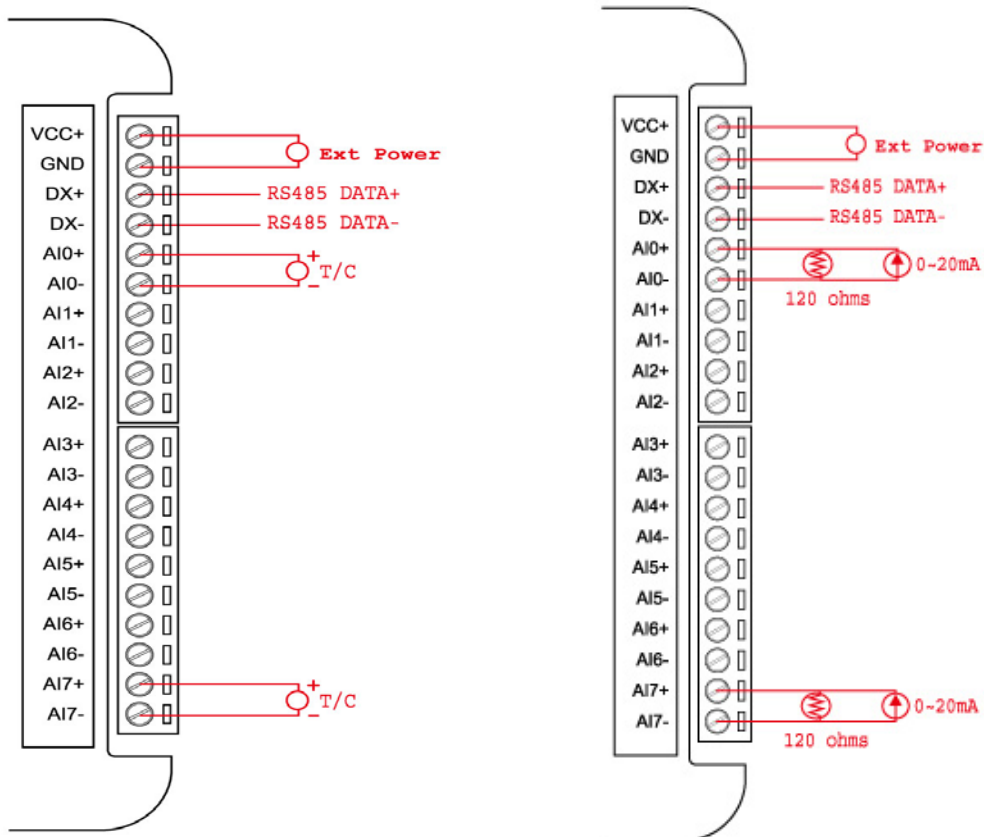

■ Digital Input Wiring

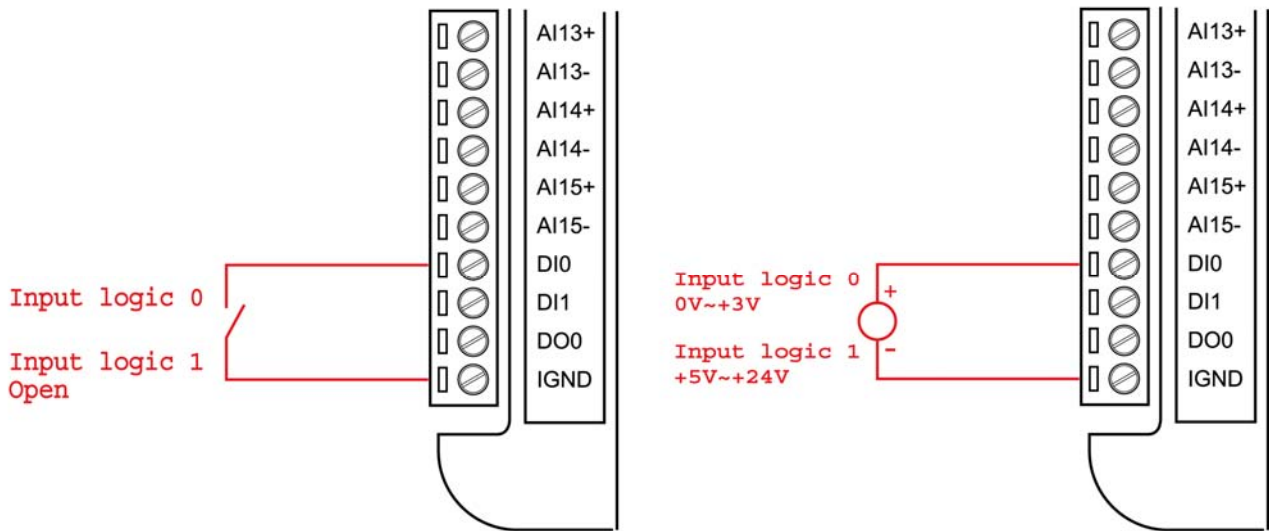

■ Digital Output Wiring

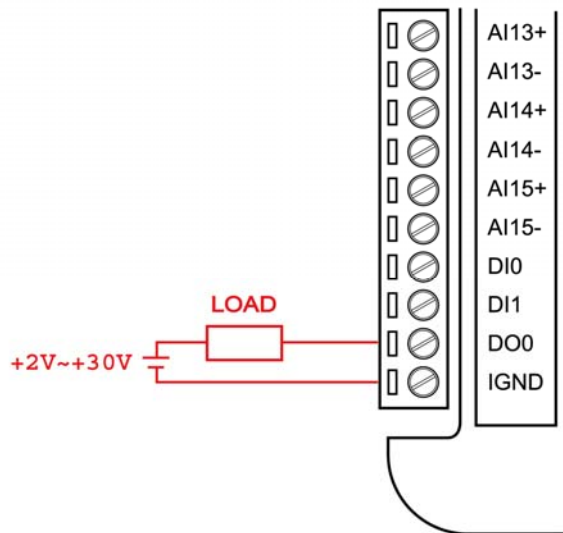

4.4 EDAM-5028 Wiring

■ Interface Connection

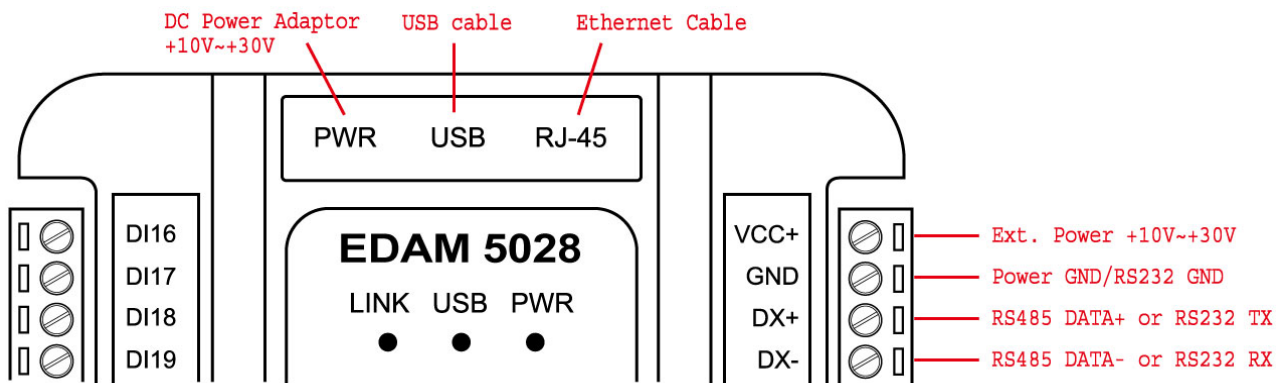

■ Digital Input Wiring

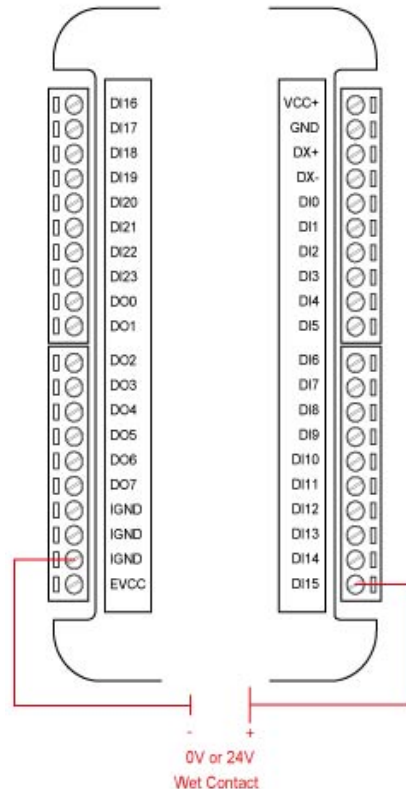
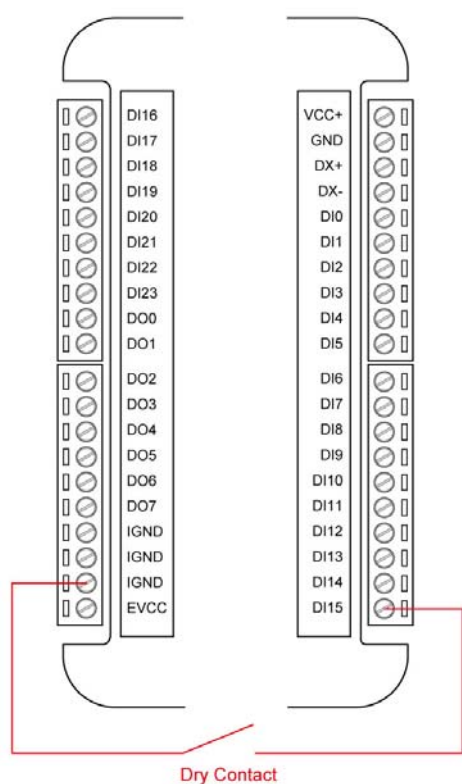
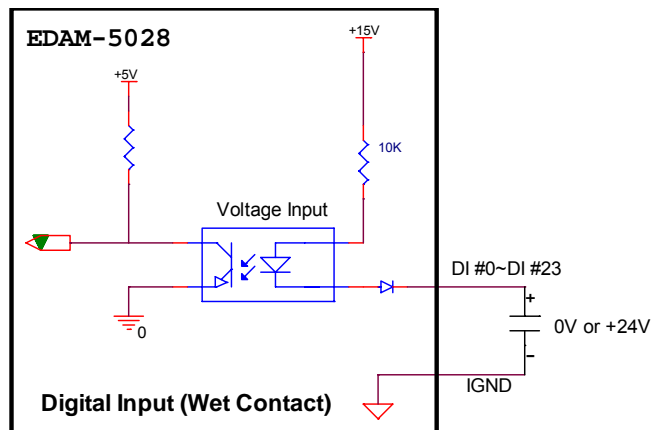
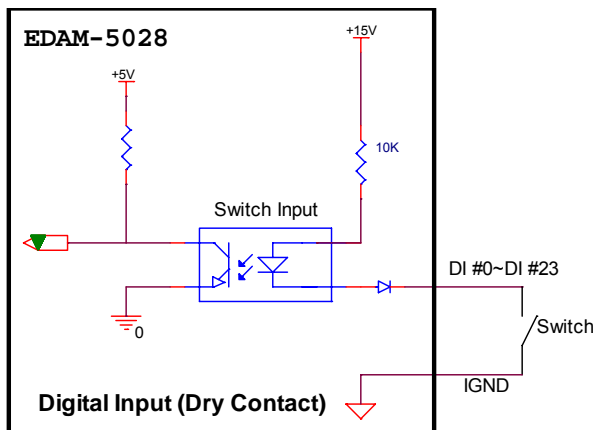

■ Digital Output Wiring

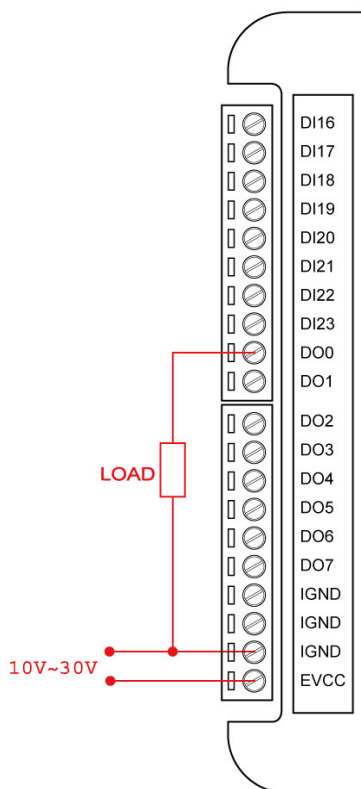
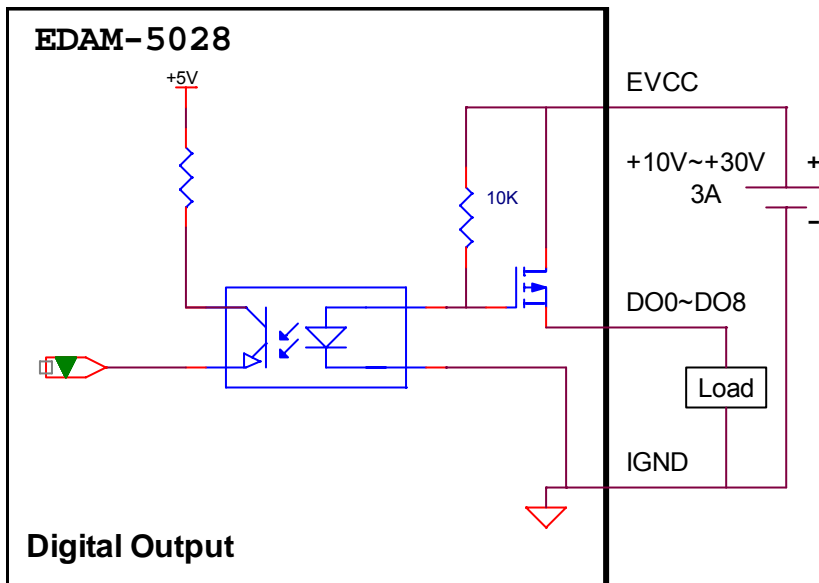

4.5 EDAM-5029 Wiring

■ Interface Connection

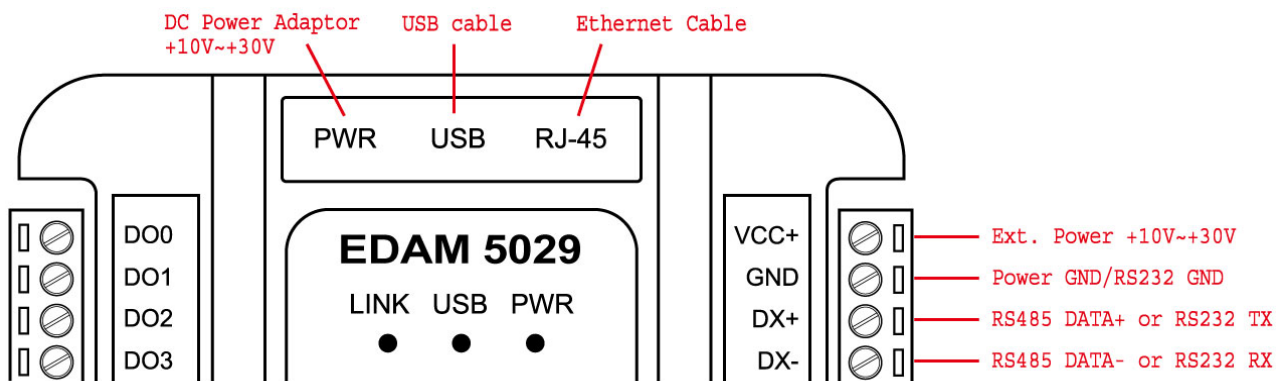

■ Digital Input Wiring

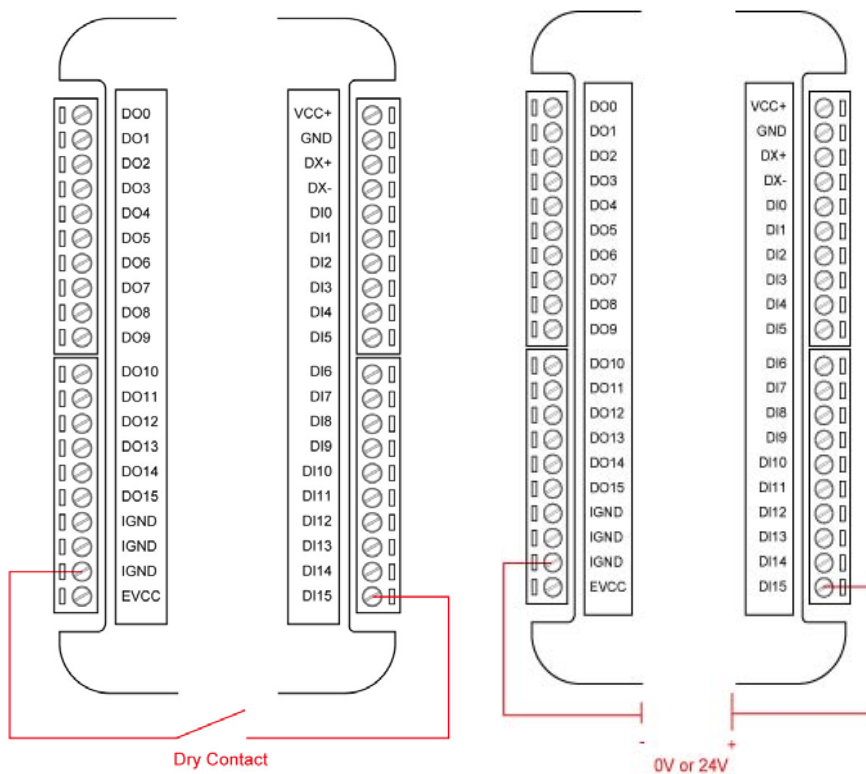
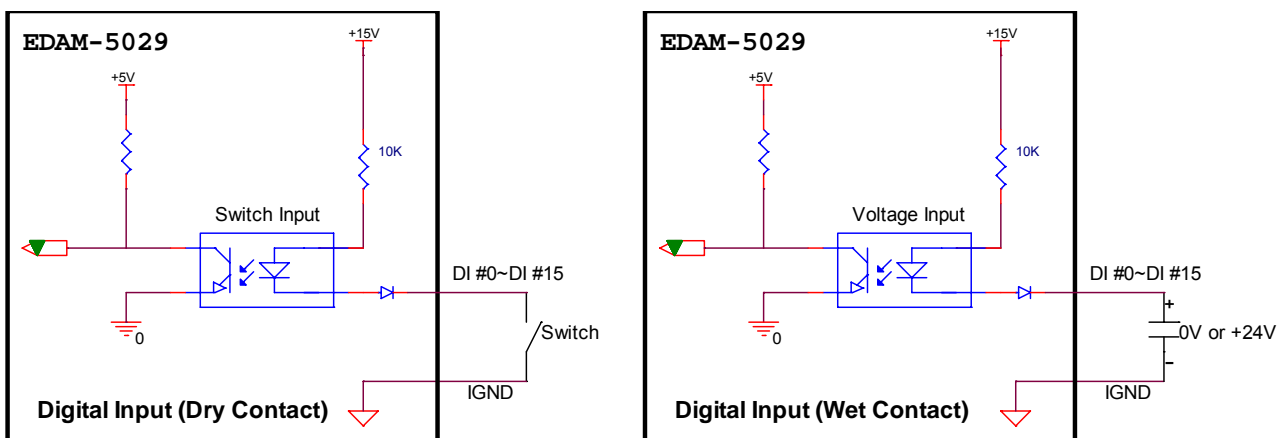

■ Digital Output Wiring

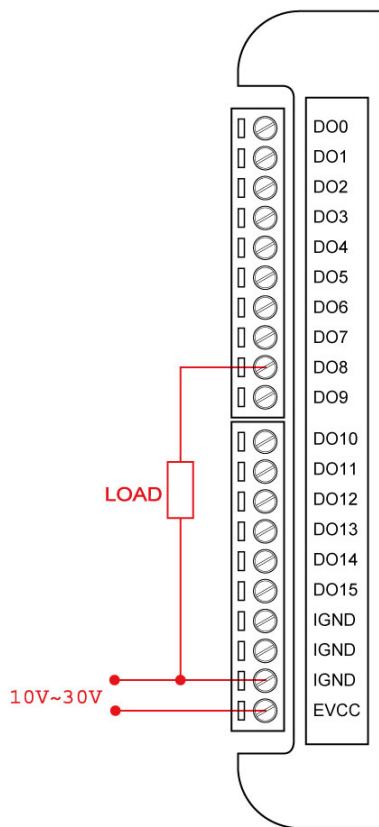
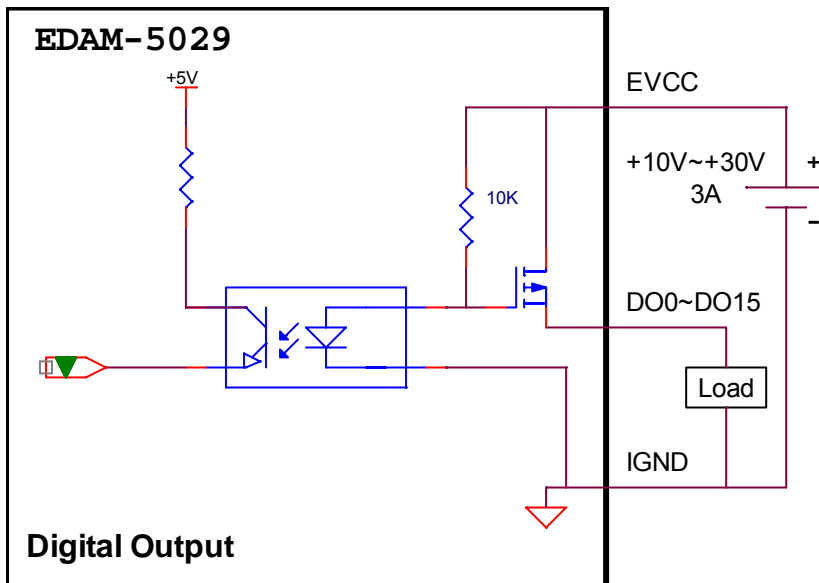

4.6 EDAM-5060 Wiring

■ Interface Connection

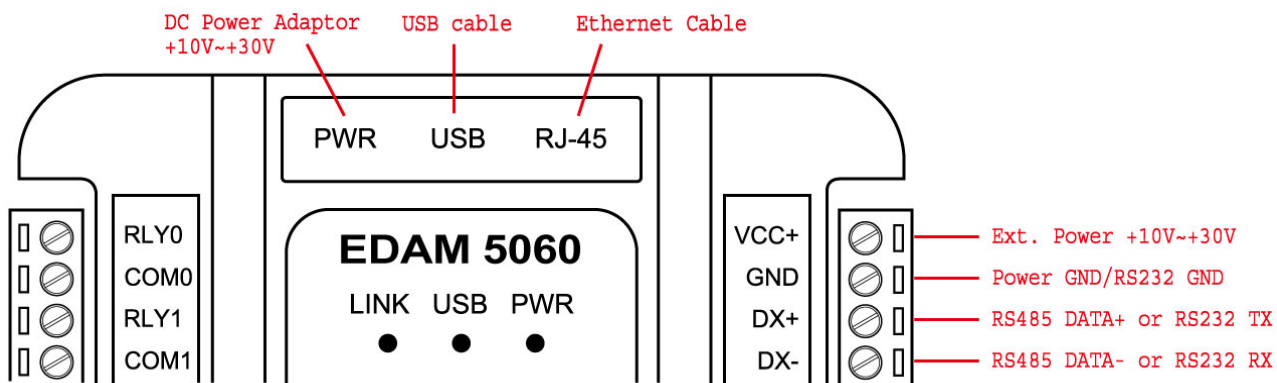

■ Digital Input Wiring

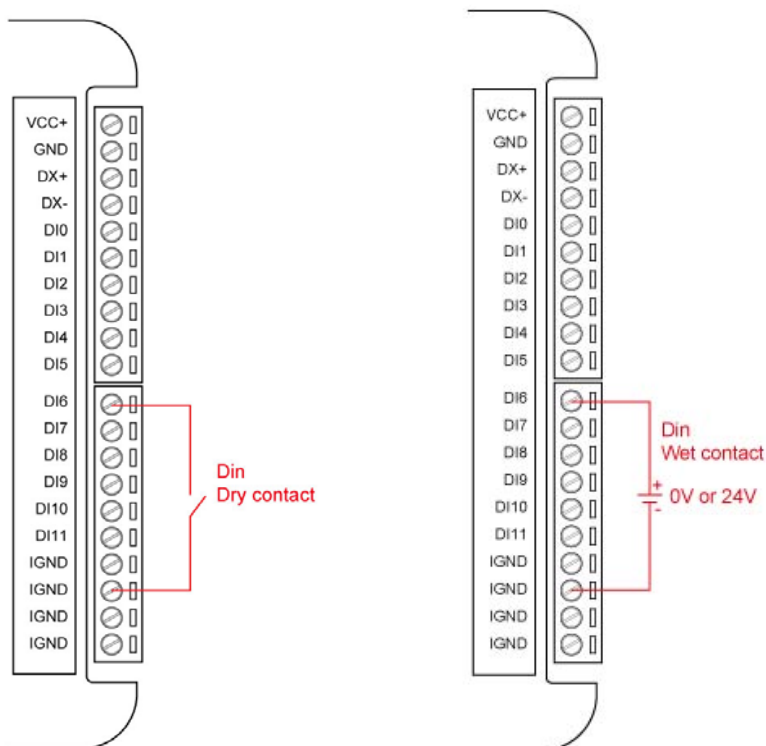
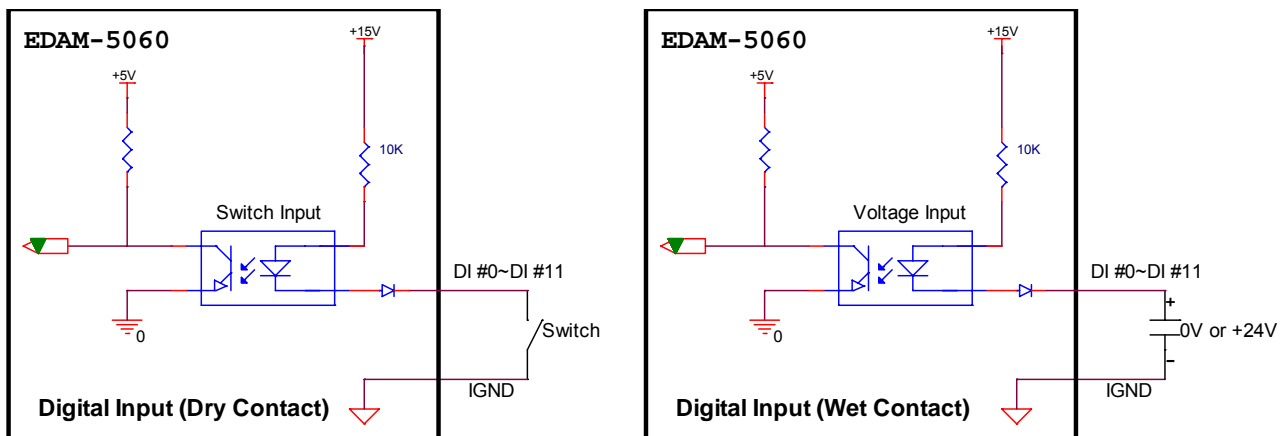

■ Digital Output Wiring

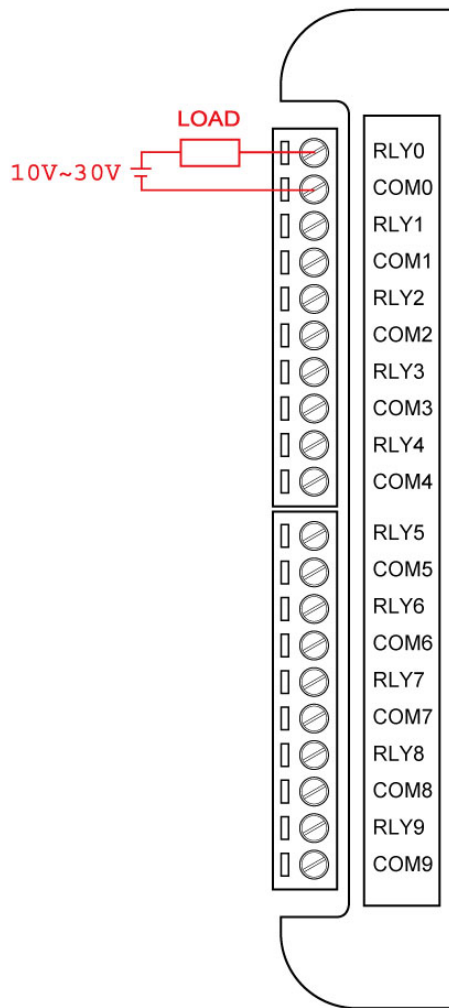
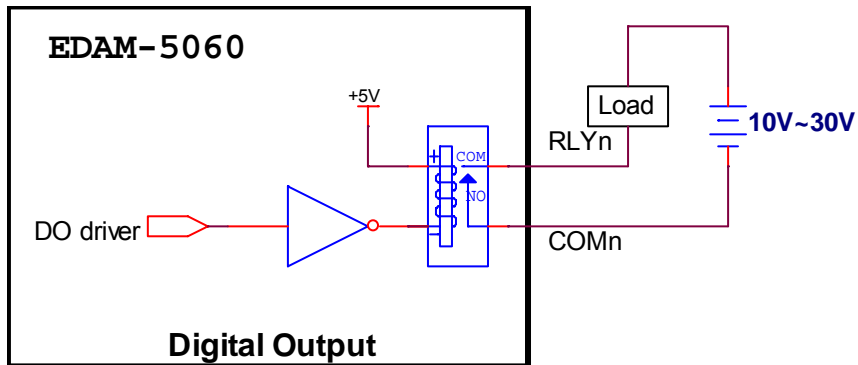

Chapter 5 Modbus Command Structure

EDAM-5000 system accepts a command/response form with the host computer. When systems are not transmitting they are in listen mode. The host issues a command to a system with a specified address and waits a certain amount of time for the system to respond. If no response arrives, a time-out aborts the sequence and returns control to the host. This chapter explains the structure of the commands with Modbus/TCP protocol, and guides to use these command sets to implement user's programs.

5.1 Command Structure

■ Modbus/TCP

It is important to understand the encapsulation of a Modbus request or response carried on the Modbus/TCP network. A complete command is consisted of **command head** and **command body**. The command head is prefixed by six bytes and responded to pack Modbus format; the command body defines target device and requested action. Following example will help you to realize this structure quickly.

Example :

If you want to read the first two values of EADM-5019 (address : 40001~40002) with Modbus/TCP protocol, the request command should be :

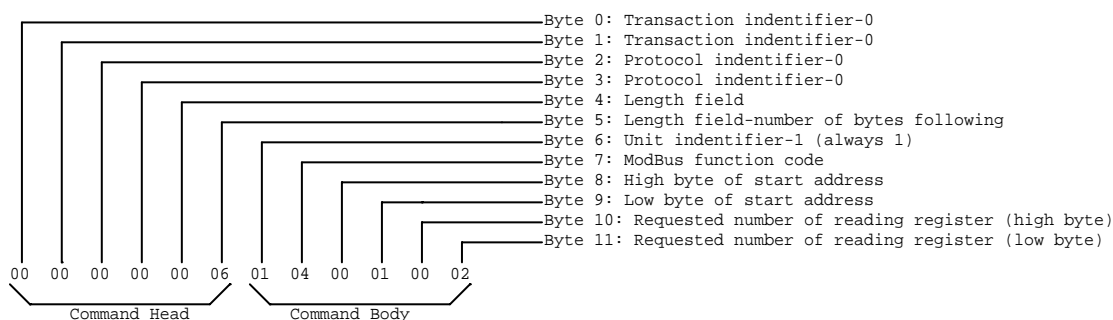

And the response should be :

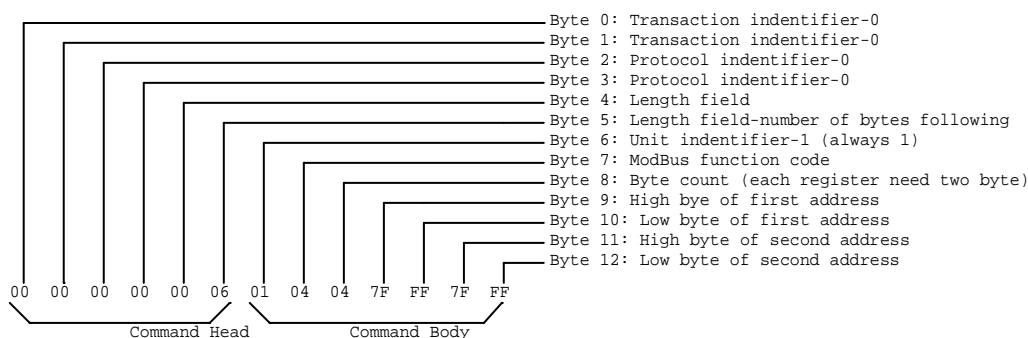

■ Modbus/RTU

A Modbus request or response carried on the Modbus/RTU network. A complete command is consisted of **command body only**. If you want to read the values of EADM-5019 with Modbus/RTU protocol, the request command is the same as Modbus/TCP, but **without Command Head and first byte of Command body should be filled with module address**

5.2 Modbus Function Code Introductions

Code (Hex)	Name	Usage
01	Read Coil Status	Read Discrete DI/DO Bit
02	Read Input Status	Read Discrete DI/DO Bit
03	Read Holding Registers	Read 16-bit register.
04	Read Input Registers	
05	Write Single Coil	Write data to force coil ON/OFF
06	Write Single Register	Write data in 16-bit integer format
0F	Force Multiple Coils	Write multiple data to force coil ON/OFF
10	Preset Multiple Registers	Write multiple data in 16-bit integer format

Chapter 6 Modbus Address Mapping

6.1 Modbus Mapping Of EDAM-5015

6.1.1 Register Address (Unit : 16 bits)

This register address mapping support Modbus function 03(0x03), 04(0x04), 06(0x06), and 16(0x10)

Where : N=30000 for Function 04(0x04)

N=40000 for Function 03(0x03), Function 06(0x06), and Function 16(0x10)

Address(dec)	Channel	Item	Attribute
N+0290~N+0290	0~15	Analog input burnout status	
N+0291~N+0290	0~15	Analog input high alarm status	R
N+0292~N+0292	0~15	Analog input low alarm status	R
N+0294~N+0309	0~15	Analog input normal value	R (see sec. 7.2)
N+0310	Average	Analog input average value	R
N+0312~N+0327	0~15	Analog input maximum value	R (see sec. 7.2)
N+0312~N+0327	0~15	Analog input maximum value	R (see sec. 7.2)
N+0330~N+0345	0~15	Analog input minimum value	R
N+0348~N+0363	0~15	Analog Input type (0x0007~0x000E)	R/W
N+0364	Average	Average type (0x0007~0x000E)	R/W

6.1.2 Bit Address (Unit : 1 bit)

This discrete address mapping support Modbus function 01(0x01), 02(0x02), 05(0x05), and 15(0x0F)

Where : N=00000 for Function 00(0x00), and 15(0x0F)

N=10000 for Function 01(0x01), Function 05(0x05)

Address(dec)	Channel	Item	Attribute
X+0256~N+0271	0~15	Enable/disable analog channel	R/W
N+0272~N+0287	0~15	Analog input high alarm status	R
N+0288~N+0303	0~15	Analog input low alarm status	R
N+0304~N+0319	0~15	Enable/disable analog channel in average	R/W
N+0320~X+0335	0~15	Reset analog input maximum value	R/W
N+0336~N+0351	0~15	Reset analog input minimum value	R/W
N+0352~N+0367	0~15	Clear analog input high alarm status	R/W
N+0368~N+0383	0~15	Clear analog input low alarm status	R/W
N+0384~N+0399	0~15	Read AD burnout status	R
N+0404		Enable/disable burnout detection (0=disable,1=enable)	R/W
N+0407		Enable/disable DHCP (0=disable,1=enable)	R/W
N+0408		Enable/disable Web Server (0=disable,1=enable)	R/W
N+0409		Enable/disable CRC/Checksum (0=disable,1=enable)	R/W

Note :

In Modbus PDU each data is addressed is numbered from 1 to n

In the Modbus data model each element within a data block is numbered from 1 to n

6.2 Modbus Mapping Of EDAM-5017

6.2.1 Register Address (Unit : 16 bits)

This register address mapping support Modbus function 03(0x03), 04(0x04), 06(0x06), and 16(0x10)

Where : N=30000 for Function 04(0x04)

N=40000 for Function 03(0x03), Function 06(0x06), and Function 16(0x10)

Address(dec)	Channel	Item	Attribute
N+0000~N+0000	0~1	Digital input data (0x0000~0x0003)	R
N+0002~N+0002	0	Digital input latch status (0x0000~0x0003)	R/W
N+0004~N+0007	0~1	Digital input counter value (2 words/channel)	R (see sec.7.1)
N+0068~N+0068	0~15	Digital output status DO0~DO15 (0x0000~0x0001)	R/W
N+0069~N+0069	16~31	Digital output status DO16~DO31 (0x0000~0x0001)	R/W
N+0080~N+0081	0~1	Digital input mode	R/W
N+0112~N+0113	0~1	Digital input denounce time interval (0~0xffff)	R/W
X+0176~N+0176	0	Digital output pulse low width (0000~0xFFFF in 0.5msec)	R/W
N+0208~N+0208	0	Digital output pulse high width (0000~0xFFFF in 0.5msec)	R/W
N+0240~N+0240	0	Digital output pulse counts	R/W
N+0272~N+0272	0~15	Digital power-on value DO0~DO15 (0x0000~0xFFFF)	R/W
N+0273~N+0273	16~31	Digital power-on value DO16~DO31 (0x0000~0xFFFF)	R/W
N+0290~N+0290	0~15	Analog input burnout status	
N+0291~N+0290	0~15	Analog input high alarm status	R
N+0292~N+0292	0~15	Analog input low alarm status	R
N+0293~N+0293	Cold junction	Cold junction temperature(in 0.1C)	R
N+0294~N+0309	0~15	Analog input normal value	R (see sec. 7.2)
N+0310	Average	Analog input average value	R
N+0312~N+0327	0~15	Analog input maximum value	R (see sec.7.2)
N+0312~N+0327	0~15	Analog input maximum value	R (see sec. 7.2)
N+0330~N+0345	0~15	Analog input minimum value	R
N+0348~N+0363	0~15	Analog Input type (0x0007~0x000E)	R/W
N+0364	Average	Average type (0x0007~0x000E)	R/W

6.2.2 Bit Address (Unit: 1 bit)

This discrete address mapping support Modbus function 01(0x01), 02(0x02), 05(0x05), and 15(0x0F)

Where : N=00000 for Function 00(0x00), and 15(0x0F)
N=10000 for Function 01(0x01), Function 05(0x05)

Address(dec)	Channel	Item	Attribute
N+0000~N+0001	0~1	DI status (0X0000~0X0003)	R
N+0032~N+0033	0~1	DI latch status (0X0000~0X0003)	R
N+0064~N+0064	0	DO status	R/W
N+0096~N+0097	0~1	Clear DI latch status	R/W
N+0128~N+0129	0~1	Clear DI counter value	R/W
N+0160~N+0161	0~1	Enable/disable DI latch interrupt/Event) 0=disable, no generate interrupt or event 1=enable, generate interrupt or event (for USB/Ethernet connections only)	R/W
N+0224~N+0224	0~1	Start/Stop DO pulse output 0=disable DO pulse output 1=enable DO pulse out until Digital output pulse counts reaches zero (see * in Register address table)	R/W
X+0256~N+0271	0~15	Enable/disable analog channel	R/W
N+0272~N+0287	0~15	Analog input high alarm status	R
N+0288~N+0303	0~15	Analog input low alarm status	R
N+0304~N+0319	0~15	Enable/disable analog channel in average	R/W
N+0320~X+0335	0~15	Reset analog input maximum value	R/W
N+0336~N+0351	0~15	Reset analog input minimum value	R/W
N+0352~N+0367	0~15	Clear analog input high alarm status	R/W
N+0368~N+0383	0~15	Clear analog input low alarm status	R/W
N+0400		Save current DO as power on value	R/W
N+0405		Set DI active state (0=Open active,1=low active)	R/W
N+0406		Set DO active state (0=low active,1=open active)	R/W
N+0407		Enable/disable DHCP (0=disable,1=enable)	R/W
N+0408		Enable/disable Web Server (0=disnable,1=enable)	R/W
N+0409		Enable/disable CRC/Checksum (0=disable,1=enable)	R/W

Note :

In Modbus PDU each data is addressed is numbered from 1 to n

In the Modbus data model each element within a data block is numbered from 1 to n

6.3 Modbus Mapping Of EDAM-5019

6.3.1 Register Address (Unit: 16 bits)

This register address mapping support Modbus function 03(0x03), 04(0x04), 06(0x06), and 16(0x10)

Where : N=30000 for Function 04(0x04)

N=40000 for Function 03(0x03), Function 06(0x06), and Function 16(0x10)

Address(dec)	Channel	Item	Attribute
N+0000~N+0000	0~1	Digital input data (0x0000~0x0003)	R
N+0002~N+0002	0	Digital input latch status (0x0000~0x0003)	R/W
N+0004~N+0007	0~1	Digital input counter value (2 words/channel)	R (see sec.7.1)
N+0068~N+0068	0~15	Digital output status DO0~DO15 (0x0000~0x0001)	R/W
N+0069~N+0069	16~31	Digital output status DO16~DO31 (0x0000~0x0001)	R/W
N+0080~N+0081	0~1	Digital input mode	R/W
N+0112~N+0113	0~1	Digital input denounce time interval (0~0xffff)	R/W
X+0176~N+0176	0	Digital output pulse low width (0000~0xFFFF in 0.5msec)	R/W
N+0208~N+0208	0	Digital output pulse high width (0000~0xFFFF in 0.5msec)	R/W
N+0240~N+0240	0	Digital output pulse counts	R/W
N+0272~N+0272	0~15	Digital power-on value DO0~DO15 (0x0000~0xFFFF)	R/W
N+0273~N+0273	16~31	Digital power-on value DO16~DO31 (0x0000~0xFFFF)	R/W
N+0290~N+0290	0~15	Analog input burnout status	
N+0291~N+0291	0~15	Analog input high alarm status	R
N+0292~N+0292	0~15	Analog input low alarm status	R
N+0293~N+0293	Cold junction	Cold junction temperature(in 0.1C)	R
N+0294~N+0309	0~15	Analog input normal value	R (see sec. 7.2)
N+0310	Average	Analog input average value	R
N+0312~N+0327	0~15	Analog input maximum value	R (see sec. 7.2)
N+0312~N+0327	0~15	Analog input maximum value	R (see sec. 7.2)
N+0330~N+0345	0~15	Analog input minimum value	R
N+0348~N+0363	0~15	Analog Input type (0x0007~0x000E)	R/W
N+0364	Average	Average type (0x0007~0x000E)	R/W
N+366~N+381	0~15	AD channel cold junction offset (in 0.01C)	R/W

6.3.2 Bit Address (Unit: 1 bit)

This discrete address mapping support Modbus function 01(0x01), 02(0x02), 05(0x05), and 15(0x0F)

Where : N=00000 for Function 00(0x00), and 15(0x0F)

N=10000 for Function 01(0x01), Function 05(0x05)

Address(dec)	Channel	Item	Attribute
N+0000~N+0001	0~1	DI status (0X0000~0X0003)	R
N+0032~N+0033	0~1	DI latch status (0X0000~0X0003)	R
N+0064~N+0064	0	DO status	R/W
N+0096~N+0097	0~1	Clear DI latch status	R/W
N+0128~N+0129	0~1	Clear DI counter value	R/W
N+0160~N+0161	0~1	Enable/disable DI latch interrupt/Event) 0=disable, no generate interrupt or event 1=enable, generate interrupt or event (for USB/Ethernet connections only)	R/W
N+0224~N+0224	0~1	Start/Stop DO pulse output 0=disable DO pulse output 1=enable DO pulse out until Digital output pulse counts reaches zero (see * in Register address table)	R/W
X+0256~N+0271	0~15	Enable/disable analog channel	R/W
N+0272~N+0287	0~15	Analog input high alarm status	R
N+0288~N+0303	0~15	Analog input low alarm status	R
N+0304~N+0319	0~15	Enable/disable analog channel in average	R/W
N+0320~X+0335	0~15	Reset analog input maximum value	R/W
N+0336~N+0351	0~15	Reset analog input minimum value	R/W
N+0352~N+0367	0~15	Clear analog input high alarm status	R/W
N+0368~N+0383	0~15	Clear analog input low alarm status	R/W
N+0384~N+0399	0~15	Read AD burnout status	R
N+0400		Save current DO as power on value	R/W
N+0404		Enable/disable burnout detection (0=disable,1=enable)	R/W
N+0405		Set DI active state (0=Open active,1=low active)	R/W
N+0406		Set DO active state (0=low active,1=open active)	R/W
N+0407		Enable/disable DHCP (0=disable,1=enable)	R/W
N+0408		Enable/disable Web Server (0=disnable,1=enable)	R/W
N+0409		Enable/disable CRC/Checksum (0=disable,1=enable)	R/W

Note :

In Modbus PDU each data is addressed is numbered from 1 to n

In the Modbus data model each element within a data block is numbered from 1 to n

6.4 Modbus Mapping Of EDAM-5028

6.4.1 Register Address (Unit: 16 bits)

This register address mapping support Modbus function 03(0x03), 04(0x04), 06(0x06), and 16(0x10)

Where : N=30000 for Function 04(0x04)

N=40000 for Function 03(0x03), Function 06(0x06), and Function 16(0x10)

Address(dec)	Channel	Item	Attribute
N+0000	0~15	Digital input data (0x0000~0xFFFF)	R
N+0001	16~23	Digital input data (0x0000~0x00FF)	R
N+0002	0~15	Digital input latch status (0x0000~0xFFFF)	R
N+0003	16~23	Digital input latch status (0x0000~0x00FF)	R
N+0004~N+0051	0~23	Digital input counter value (2 words/channel)	R (see sec.7.1)
N+0068	0~7	Digital output status DO0~DO7(0x0000~0x00FF)	R/W
N+0080~N+0103	0~23	Digital input mode	R/W
N+0112~N+0135	0~23	Digital input denounce time interval (0~0xFFFF)	R/W
X+0176~N+0183	0~7	Digital output pulse low width (0000~0xFFFF in 0.5msec)	R/W
N+0208~N+0215	0~7	Digital output pulse high width (0000~0xFFFF in 0.5msec)	R/W
N+0240~N+0247	0~7	Digital output pulse counts	R/W
N+0272	0~7	Digital power-on value DO0~DO7 (0x0000~0xFFFF)	R/W

6.4.2 Bit Address (Unit: 1 bit)

This discrete address mapping support Modbus function 01(0x01), 02(0x02), 05(0x05), and 15(0x0F)

Where : N=00000 for Function 00(0x00), and 15(0x0F)

N=10000 for Function 01(0x01), Function 05(0x05)

Address(dec)	Channel	Item	Attribute
N+0000~N+0023	0~23	DI status (0X000000~0XFFFFFF)	R
N+0032~N+0055	0~23	DI latch status (0X000000~0XFFFFFF)	R
N+0064~N+0071	0~7	DO status	R/W
N+0096~N+0119	0~23	Clear DI latch status	R/W
N+0128~N+0151	0~23	Clear DI counter value	R/W
N+0160~N+0183	0~23	Enable/disable DI latch interrupt/Event 0=disable, no generate interrupt or event 1=enable, generate interrupt or event (for USB/Ethernet connections only)	R/W
N+0224~N+0231	0~7	Start/Stop DO pulse output 0=disable DO pulse output 1=enable DO pulse out until Digital output pulse counts reaches zero (see * in Register address table)	R/W
N+0400		Save current DO as power on value	R/W
N+0405		Set DI active state (0=Open active,1=low active)	R/W
N+0406		Set DO active state (0=low active,1=open active)	R/W
N+0407		Enable/disable DHCP (0=disable,1=enable)	R/W
N+0408		Enable/disable Web Server (0=disable,1=enable)	R/W
N+0409		Enable/disable CRC/Checksum (0=disable,1=enable)	R/W

Note:

In Modbus PDU each data is addressed is numbered from 1 to n

In the Modbus data model each element within a data block is numbered from 1 to n

6.5 Modbus Mapping Of EDAM-5029

6.5.1 Register Address (Unit: 16 bits)

This register address mapping support Modbus function 03(0x03), 04(0x04), 06(0x06), and 16(0x10)

Where : N=30000 for Function 04(0x04)

N=40000 for Function 03(0x03), Function 06(0x06), and Function 16(0x10)

Address(dec)	Channel	Item	Attribute
N+0000	0~15	Digital input data (0x0000~0xFFFF)	R
N+0002	0~15	Digital input latch status (0x0000~0xFFFF)	R
N+0004~N+0035	0~15	Digital input counter value (2 words/channel)	R (see sec.7.1)
N+0068	0~15	Digital output status DO0~DO15 (0x0000~0xFFFF)	R/W
N+0080~N+0095	0~15	Digital input mode	R/W
N+0112~N+0127	0~15	Digital input debounce time interval (0~0xFFFF)	R/W
X+0176~N+0191	0~15	Digital output pulse low width (0000~0xFFFF in 0.5msec)	R/W
N+0208~N+0223	0~15	Digital output pulse high width (0000~0xFFFF in 0.5msec)	R/W
N+0240~N+0255	0~15	Digital output pulse counts	R/W
N+0272	0~7	Digital power-on value DO0~DO15 (0x0000~0xFFFF)	R/W

6.5.2 Bit Address (Unit: 1 bit)

This discrete address mapping support Modbus function 01(0x01), 02(0x02), 05(0x05), and 15(0x0F)

Where : N=00000 for Function 00(0x00), and 15(0x0F)

N=10000 for Function 01(0x01), Function 05(0x05)

Address(dec)	Channel	Item	Attribute
N+0000~N+0015	0~15	DI status (0X0000~0XFFFF)	R
N+0032~N+0047	0~15	DI latch status (0X0000~0XFFFF)	R
N+0064~N+0079	0~15	DO status	R/W
N+0096~N+0111	0~15	Clear DI latch status	R/W
N+0128~N+0143	0~15	Clear DI counter value	R/W
N+0160~N+0175	0~15	Enable/disable DI latch interrupt/Event 0=disable, no generate interrupt or event 1=enable, generate interrupt or event (for USB/Ethernet connections only)	R/W
N+0224~N+0239	0~15	Start/Stop DO pulse output 0=disable DO pulse output 1=enable DO pulse out until Digital output pulse counts reaches zero (see * in Register address table)	R/W
N+0400		Save current DO as power on value	R/W
N+0405		Set DI active state (0=Open active,1=low active)	R/W
N+0406		Set DO active state (0=low active,1=open active)	R/W
N+0407		Enable/disable DHCP (0=disable,1=enable)	R/W
N+0408		Enable/disable Web Server (0=disable,1=enable)	R/W
N+0409		Enable/disable CRC/Checksum (0=disable,1=enable)	R/W

Note:

**In Modbus PDU each data is addressed is numbered from 1 to n
In the Modbus data model each element within a data block is numbered from 1 to n**

6.6 Modbus Mapping Of EDAM-5060

6.6.1 Register Address (Unit: 16 bits)

This register address mapping support Modbus function 03(0x03), 04(0x04), 06(0x06), and 16(0x10)

Where : N=30000 for Function 04(0x04)

N=40000 for Function 03(0x03), Function 06(0x06), and Function 16(0x10)

Address(dec)	Channel	Item	Attribute
N+0000	0~11	Digital input data (0x0000~0x0FFF)	R
N+0002	0~11	Digital input latch status (0x0000~0x0FFF)	R
N+0004~N+0027	0~11	Digital input counter value (2 words/channel)	R (see sec.7.1)
N+0068	0~9	Digital output status DO0~DO9 (0x0000~0x03FF)	R/W
N+0080~N+0091	0~11	Digital input mode	R/W
N+0112~N+0123	0~15	Digital input denounce time interval (0~0xFFFF)	R/W
X+0176~N+0187	0~15	Digital output pulse low width (0000~0xFFFF in 0.5msec)	R/W
N+0208~N+0217	0~9	Digital output pulse high width (0000~0xFFFF in 0.5msec)	R/W
N+0240~N+0249	0~9	Digital output pulse counts	R/W
N+0272	0~9	Digital power-on value DO0~DO9 (0x0000~0xFFFF)	R/W

6.6.2 Bit Address (Unit: 1 bit)

This discrete address mapping support Modbus function 01(0x01), 02(0x02), 05(0x05), and 15(0x0F)

Where : N=00000 for Function 00(0x00), and 15(0x0F)

N=10000 for Function 01(0x01), Function 05(0x05)

Address(dec)	Channel	Item	Attribute
N+0000~N+0011	0~11	DI status (0X000~0XFFF)	R
N+0032~N+0043	0~11	DI latch status (0X000~0XFFF)	R
N+0064~N+0073	0~9	DO status	R/W
N+0096~N+0107	0~11	Clear DI latch status	R/W
N+0128~N+0139	0~11	Clear DI counter value	R/W
N+0160~N+0171	0~11	Enable/disable DI latch interrupt/Event 0=disable, no generate interrupt or event 1=enable, generate interrupt or event (for USB/Ethernet connections only)	R/W
N+0224~N+0233	0~9	Start/Stop DO pulse output 0=disable DO pulse output 1=enable DO pulse out until Digital output pulse counts reaches zero (see * in Register address table)	R/W
N+0400		Save current DO as power on value	R/W
N+0405		Set DI active state (0=Open active,1=low active)	R/W
N+0406		Set DO active state (0=low active,1=open active)	R/W
N+0407		Enable/disable DHCP (0=disable,1=enable)	R/W
N+0408		Enable/disable Web Server (0=disable,1=enable)	R/W
N+0409		Enable/disable CRC/Checksum (0=disable,1=enable)	R/W

Note :

In Modbus PDU each data is addressed is numbered from 1 to n

In the Modbus data model each element within a data block is numbered from 1 to n

Chapter 7 Modbus Data Conversion

This chapter shows you how to convert Modbus register data to actual analog and digital value

7.1 How To Calculate DI Counter Value

Formula :

Actual DI Channel counts = (register value (high word) <<16) + register value (low word)

Example 1 written with C :

- 1、 Assume the type of DI Channel 0 and channel 1 function as counter/frequency mode
- 2、 Send Request command as : (Note : 0x7534=30004 start address of counter value of DI channel 0)

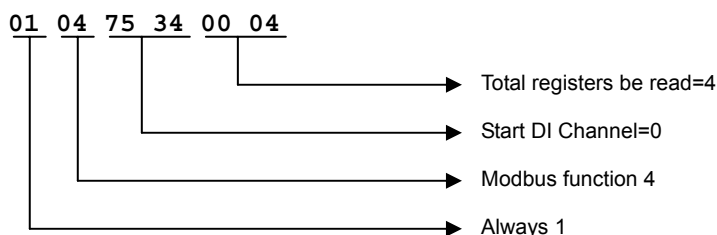

- 3、 Receive Response from module as :

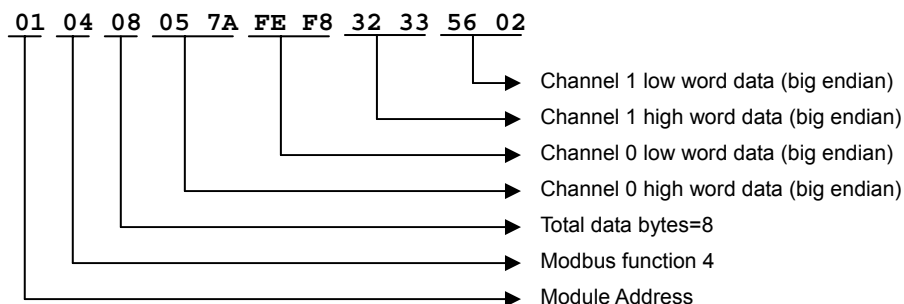

```

Char Resp_data [];//Modbus response data received from Module
//where Resp_data[6]=01 ; module address
// Resp_data[7]=04 ; Modbus function 4
// Resp_data[8]=08 ; total data bytes
// Resp_data[9],[10]= 0x05,0x7A ;high data of channel 0
// Resp_data[11],[12]= 0xFE,0xF8 ;low data of channel 0
// Resp_data[13],[14]= 0x32,0x33 ;high data of channel 1
// Resp_data[15],[16]= 0x56,0x02 ;low data of channel 1
long Chan0_Counts, Chan1_Counts;
Chan0_Counts =((long)Resp_data[9]<<24) | ((long)Resp_data[10]<<16) |
((long)Resp_data[11]<<8) | Resp_data[12];
Chan1_Counts =((long)Resp_data[13]<<24) | ((long)Resp_data[14]<<16) |
((long)Resp_data[15]<<8) | Resp_data[16];
printf ("\n\rChan 0 Counts=%d", Chan0_Counts);
printf ("\n\rChan 1 Counts=%d", Chan1_Counts);
    
```

4. Result :

Chan 0 Counts =91946744
 Chan 1 Counts =842225154

7.2 How To Convert Modbus Data To AI Voltage/Temperature

7.2.1 Engineering Data Format Table

Type	Input Type	Min.	Max.	Formula	Unit
07	-10V ~ +10V	-10000	+10000	Volt=(MODBUS data) /1000	V
08	-5V ~ + 5V	-5000	+5000	Volt=(MODBUS data) /1000	
09	-2.5V ~ +2.5V	-2500	+2500	Volt=(MODBUS data) /1000	
0A	-1V ~ +1V	-10000	+10000	Volt=(MODBUS data) /10000	mV
0B	-500 mV ~ +500 mV	-5000	+5000	Volt=(MODBUS data) /10	
0C	-150m V ~ +150mV	-15000	+15000	Volt=(MODBUS data) /100	mA
0D	0 mA ~ +20 mA	00000	+20000	Current=(MODBUS data) /1000	
0E	4-20MA	4000	+20000	Current=(MODBUS data) /1000	°C
0F	Type J T/C (-100°C to 760°C)	-1000	7600	Temperature=(MODBUS data) /10	
10	Type K T/C (-100°C to 1370°C)	-1000	13700		
11	Type T T/C (-100°C to 400°C)	-1000	4000		
12	Type E T/C (-100°C to 1000°C)	-1000	10000		
13	Type R T/C (-50°C to 1750°C)	-500	17500		
14	Type S T/C (-50°C to 1750°C)	-500	17500		
15	Type B T/C (00°C to 1800°C)	0	18000		
20	IEC Pt100 (-50C~ 150C)	-500	1500		
21	IEC Pt100 (0C ~ 100C)	0	1000		
22	IEC Pt100 (0C ~ 200C)	0	2000		
23	IEC Pt100 (0C ~ 400C)	0	4000		
24	IEC Pt100 (-200C ~ 200C)	-2000	2000		
25	JIS Pt100 (-50C ~ 150C)	-500	1500		
26	JIS Pt100 (0C ~ 100C)	0	1000		
27	JIS Pt100 (0C~ 200C)	0	2000		
28	JIS Pt100 (0C ~ 400C)	0	4000		
29	JIS Pt100 (-200C ~ 200C)	-2000	2000		
2A	PT1000 (-40C ~ 160C)	-400	1600		
B	BALCO500 (-30C ~ 120C)	-300	1200		
C	Ni604 (-80C ~ 100C)	-800	1000		
D	Ni604 (0C~ 100C)	0	1000		

Example : Assume type of channel 2 is **+/-10V** and MODBUS data=0x2030(Hex)=8240(Dec)

The voltage of channel 2 is **8240/1000=8.24V**

Example : Assume type of channel 1 is **+/-500mV** and MODBUS data=0xEF1B(Hex)=-4325(Dec)

The voltage of channel 2 is **-4235/10=423.5mV**

Example : Assume type of channel 1 is **0~20mA** and MODBUS data=0x3B84(Hex)=15236(Dec)

The current of channel 2 is **15236/1000=15.236mA**

Example : Assume type of channel 2 is **Type K T/C (-100°C to 1370°C)** and Modbus data=0x2030(Hex)=8240(Dec)

The temperature of channel 2 is **8240/10=824.0 °C**

Example : Assume type of channel 2 is **IEC Pt100 (0C ~ 200C)** and Modbus data=0x05DC(Hex)=1500(Dec)

The temperature of channel 2 is **(1500/10=150 °C**

7.2.2 Hex 2's Complement Data Format Table

Type	Input Type	Min	Max.	Formula	Unit
07	-10V ~ +10V	8000	7FFF	$\text{Volt}=(\text{MODBUS data} * 10)/32767$	V
08	-5V ~ + 5V	8000	7FFF	$\text{Volt}=(\text{MODBUS data} * 5)/32767$	
09	-2.5V ~ +2.5V	8000	7FFF	$\text{Volt}=(\text{MODBUS data} * 2.5)/32767$	
0A	-1V ~ +1V	8000	7FFF	$\text{Volt}=(\text{MODBUS data} * 1)/32767$	
0B	-500 mV ~ +500 mV	8000	7FFF	$\text{Volt}=(\text{MODBUS data} * 500)/32767$	mV
0C	-150m V ~ +150mV	8000	7FFF	$\text{Volt}=(\text{MODBUS data} * 150)/32767$	
0D	0 mA ~ +20 mA	8000	7FFF	$\text{Current}=(\text{MODBUS data} * 20)/32767$	mA
0E	4-20MA	E667	7FFF	$\text{Current}=(\text{MODBUS data} * 20)/32767$	
0F	Type J T/C (-100°C to 760°C)	EF28	7FFF	$\text{Temperature}=(\text{MODBUS data}) / 10$	°C
10	Type K T/C (-100°C to 1370°C)	F6A8	7FFF	$\text{Temp.}=(\text{Modbus data} * 1370) / 32767$	
11	Type T T/C (-100°C to 400°C)	E000	7FFF	$\text{Temp.}=(\text{Modbus data} * 400) / 32767$	
12	Type E T/C (-100°C to 1000°C)	F333	7FFF	$\text{Temp.}=(\text{Modbus data} * 1000) / 32767$	
13	Type R T/C (-50°C to 1750°C)	FC57	7FFF	$\text{Temp.}=(\text{Modbus data} * 1750) / 32767$	
14	Type S T/C (-50°C to 1750°C)	FC57	7FFF	$\text{Temp.}=(\text{Modbus data} * 1750) / 32767$	
15	Type B T/C (00°C to 1800°C)	0	7FFF	$\text{Temp.}=(\text{Modbus data} * 1800) / 32767$	
20	IEC Pt100 (-50C~ 150C)	D555	7FFF	$\text{Temp.}=(\text{Modbus data} * 150) / 32767$	
21	IEC Pt100 (0C ~ 100C)	0	7FFF	$\text{Temp.}=(\text{Modbus data} * 100) / 32767$	
22	IEC Pt100 (0C ~ 200C)	0	7FFF	$\text{Temp.}=(\text{Modbus data} * 200) / 32767$	
23	IEC Pt100 (0C ~ 400C)	0	7FFF	$\text{Temp.}=(\text{Modbus data} * 400) / 32767$	
24	IEC Pt100 (-200C ~ 200C)	8000	7FFF	$\text{Temp.}=(\text{Modbus data} * 200) / 32767$	
25	JIS Pt100 (-50C ~ 150C)	D555	7FFF	$\text{Temp.}=(\text{Modbus data} * 150) / 32767$	
26	JIS Pt100 (0C ~ 100C)	0	7FFF	$\text{Temp.}=(\text{Modbus data} * 100) / 32767$	
27	JIS Pt100 (0C~ 200C)	0	7FFF	$\text{Temp.}=(\text{Modbus data} * 200) / 32767$	
28	JIS Pt100 (0C ~ 400C)	0	7FFF	$\text{Temp.}=(\text{Modbus data} * 400) / 32767$	
29	JIS Pt100 (-200C ~ 200C)	8000	7FFF	$\text{Temp.}=(\text{Modbus data} * 200) / 32767$	
2A	PT1000 (-40C ~ 160C)	E000	7FFF	$\text{Temp.}=(\text{Modbus data} * 160) / 32767$	
2B	BALCO500 (-30C ~ 120C)	E000	7FFF	$\text{Temp.}=(\text{Modbus data} * 120) / 32767$	
2C	Ni604 (-80C ~ 100C)	9999	7FFF	$\text{Temp.}=(\text{Modbus data} * 100) / 32767$	
2D	Ni604 (0C~ 100C)	0	1000	$\text{Temp.}=(\text{Modbus data} * 100) / 32767$	

- Example : Assume type of channel 2 is +/-10V and MODBUS data=0x2030(Hex)=8240(Dec)
 The voltage of channel 2 is $(8240 * 10) / 32767 = 2.514V$
- Example : Assume type of channel 1 is +/-500mV and MODBUS data=0xEF1B(Hex)=-4325(Dec)
 The voltage of channel 2 is $(-4235 * 500) / 32767 = -64.622mV$
- Example : Assume type of channel 1 is 0~20mA and MODBUS data=0x3B84(Hex)=15236(Dec)
 The current of channel 2 is $(15236 * 20) / 32767 = 9.299mA$
- Example : Assume type of channel 2 is Type K T/C (-100°C to 1370°C) and Modbus data=0x2030(Hex)=8240(Dec)
 The temperature of channel 2 is $(8240 * 1370) / 32767 = 344.51 °C$
- Example : Assume type of channel 1 is IEC Pt100 (-200C ~ 200C) and Modbus data=0xC001(Hex)=-16383(Dec)
 The TEMPERATURE of channel 2 is $(-16383 * 200) / 32767 = -99.996 °C$

Chapter 8 Analog And Digital I/O Channel Type

8.1 DI Channel Types

Code	Type,	Models
00	DI transparent	5017,5019,5028,5029,5060
01	Counter	5017,5019,5028,5029,5060
02	Low to high latch	5017,5019,5028,5029,5060
03	High to low latch	5017,5019,5028,5029,5060
04	Frequency	5017,5019,5028,5029,5060

8.2 AI Channel Types

Code	Type and Range	Models
0x07	+/-10V	5017
0x08	+/-5V	5017
0x09	+/-2.5V	5017,5019
0x0A	+/-1V	5017,5019
0x0B	+/-500mV	5017,5019
0x0C	+/-150mV	5017,5019
0x0D	0-20mA (125 ohms)	5017,5019
0x0E	4-20mA (125 ohms)	5017,5019
0x0F	T/C J type (-100C~760C)	5019
0x10	T/C K type (-100C~1370C)	5019
0x11	T/C T type (-100C~400C)	5019
0x12	T/C E type (-100C~1000C)	5019
0x13	T/C R type (-500C~1750C)	5019
0x14	T/C S type (-500C~1750C)	5019
0x15	T/C B type (0C~1800C)	5019
0x20	RTD IEC Pt100 (-50C ~ 150C)	5015
0x21	RTD IEC Pt100 (0C ~ 100C)	5015
0x22	RTD IEC Pt100 (0C ~ 200C)	5015
0x23	RTD IEC Pt100 (0C ~ 400C)	5015
0x24	RTD IEC Pt100 (-200C ~ 200C)	5015
0x25	RTD JIS Pt100 (-50C ~ 150C)	5015
0x26	RTD JIS Pt100 (0C ~ 100C)	5015
0x27	RTD JIS Pt100 (0C ~ 200C)	5015
0x28	RTD JIS Pt100 (0C ~ 400C)	5015
0x29	RTD JIS Pt100 (-200C ~ 200C)	5015
0x2A	RTD Pt1000 (-40C ~ 160C)	5015
0x2B	RTD BALCO500 (-30C ~ 120C)	5015
0x2C	RTD Ni (-80C ~ 100C)	5015
0x2D	RTD Ni (0C ~ 100C)	5015

Chapter 9 TCP/IP Port Assignments

The following table shows you the TCP/IP ports used for EDAM-5000 series

Functions	Protocol	Port
Modbus/TCP protocol	TCP	502
ASCII command /Modbus RTU protocol	UDP	1025
Broadcast protocol	UDP	5048
Stream data	UDP	5148
Alarm Event data	UDP	5168
Httpd (web server)	TCP	80

Chapter 10 ASCII Commands

10.1 Common Commands

\$AACRC	Read CRC Status	10.4.1
\$AACRCv	Enabled/Disable CRC	10.4.2
\$AA5	Reads The Reset Status	10.4.3
\$AAF	Reads The Firmware Version	10.4.4
\$AAGATE	Read Gateway Address	10.4.5
\$AAGATEnnnnnnnn	Set Gateway Address	10.4.6
\$AAIP	Read IP Address	10.4.7
\$AAIPnnnnnnnn	Set IP Address	10.4.8
\$AAM	Read Module Name	10.4.9
~AAO(name)	Set model name	10.4.10
\$AAMASK	Read Mask Address	10.4.11
\$AAMASKnnnnnnnn	Set Mask Address	10.4.12
\$AAP	Read Communication Protocol	10.4.13
\$AAP?	Set Communication Protocol	10.4.14
\$AASW	Read Web Server Status	10.4.15
\$AASWv	Enabled/Disable Web Server	10.4.16
\$AADHCPv	Enabled/Disable DHCP	10.4.18
\$AADHCP	Read DHCP Status	10.4.17
^AAMAC	Read MAC Address	10.4.19
~AA6v	Set LED control	10.4.20
~AA6ddddddd	Write Data to LED board	10.4.21
~AA6dddddddnnnn	Force LED to flash for specified times	10.4.22
~AA3eTTTTddd	Write Communication Timeout settings (*)	10.4.23
~AA31	Read Communication Timeout Settings (*)	10.4.24

(*) 1. for all module with firmware version 5.5 or later

10.2 Digital Commands

@AA	Reads the Digital I/O Status	10.4.57
@AAAnn	Sets the Digital Output Channels(DO0~DO7)	10.4.58
@AAAnnnn	Sets the Digital Output Channels(DO0~DO15)	10.4.59
@AAAnnnnnn	Sets the Digital Output Channels(DO0~DO23)	10.4.60
#AA0Ann	Sets the Digital 1's byte(DO0~DO7) Output	10.4.61
#AA0Bnn	Sets the Digital 2's byte(DO8~DO15) Output	10.4.62
#AA0Cnn	Sets the Digital 3's byte(DO16~DO23) Output	10.4.63
#AAAnn	Reads the Digital Input Counter	10.4.64
\$AACn	Clears the Digital Input Counter	10.4.65
\$AACnn	Clears the Digital Input Counter	10.4.66
\$AALS	Reads the Latched DI Status	10.4.67
\$AAC	Clears the Latched DI Status	10.4.68
\$AA9nn	Read Single Do Pulse High/Low Width	10.4.69
\$AA9nnhhhhllll	Set Single Do Pulse High/Low Width	10.4.70
\$AAAnn	Read Single Do High/Low Delay Width	10.4.71
\$AAAnnhhhhllll	Set Single Do High/Low Delay Width	10.4.72
\$AABnn	Read Single Do Pulse Counts	10.4.73
#AA2nncccc	Write Single Do Pulse Counts	10.4.74
#AA3nns	Start/Stop Do Pulse Counts	10.4.75
~AA4v	Reads the Power On/Safe Value	10.4.77
~AA5v	Sets current DO value as Power On/Safe Value	10.4.78
~AA5vnnnnnn	Sets specified value as Power On/Safe Value	10.4.79
~AAD	Read DI/O active state	10.4.80
~AADvv	Set DI/O active state	10.4.81
~AASDBv	Set digital input debounce mode (**)	10.4.82
~AARDB	Read digital input debounce mode (**)	10.4.83

(**) 1. for the modules have digital input channels and with firmware version 5.5 or later

10.3 Analog Commands

#AA	Reads the Analog Inputs of All	10.4.25
#AAAn	Reads the single Analog Input	10.4.26
#AAMH	Read Maximum Value Of All Channels	10.4.27
#AAMHn	Read Maximum Value Of Specified Channel	10.4.28
\$AAMH	Clear All Maximum Value	10.4.29
\$AAMHn	Clear Maximum Value Of Specified Channel	10.4.30
#AAML	Read Minimum Value Of All Channels	10.4.31
#AAMLn	Read Minimum Value Of Specified Channel	10.4.32
\$AAML	Clear All Minimum Value	10.4.33
\$AAMLn	Clear Minimum Value Of Specified Channel	10.4.34
#AAAV	Read Average Value	10.4.35
\$AAE	Read Channel Average Enable/Disable Status	10.4.36
\$AAEnnnn	Disable/Enable Channel in Average	10.4.37
#AAAL	Read AD high/low Alarm Status	10.4.38
\$AAAHnnnn	Clear A/D High Alarm	10.4.39
\$AAALnnnn	Clear A/D Low Alarm	10.4.40
\$AAB	Reads Channel burnout Status	10.4.41
%AAB	Read channel burnout enable/disable status	10.4.42
%AABn	enable/disable channel burnout	10.4.43
\$AA3	Reads the CJC Temperature	10.4.44
~AAC	Reads the CJC Enable/disable	10.4.45
~AACn	Enables/Disables the CJC	10.4.46
\$AA9Snnnn	Sets the all channel CJC Offset	10.4.47
\$AA9c	Read single channel CJC Offset	10.4.48
\$AA9cSnnnn	Set single channel CJC Offset	10.4.49
\$AAR	Read A/D Filter Value	10.4.50
\$AARf	Set A/D Filter Value	10.4.51
\$AA6	Reads the Channel Enable/Disable Status	10.4.52
\$AA5vvvv	Enables/Disables A/D Channel	10.4.53
\$AA8Ci	Reads the Single A/D Channel Range	10.4.54
\$AA7CiRrr	Sets the Single Channel Range	10.4.55
\$AAS1	Reloads the Default Calibration	10.4.56

10.4 Command Description

10.4.1 \$AACRC Read CRC Status

Description	The command will return the ASCII command check sum and modbus RTU CRC status.
Syntax	<p>\$AACRC(cr)</p> <p># is a delimiter character.</p> <p>AA (range 00-FF) represents the 2-character hexadecimal address of an analog input module.</p> <p>CRC the ASCII protocol check sum and modbus RTU CRC status command</p> <p>(cr) is the terminating character, carriage return (0Dh).</p>
Response	<p>!AAv(cr) if the command is valid or ?AA (cr) if the command is invalid</p> <p>There is no response if the module detects a syntax error or communication error.</p> <p>AA (range 00-FF) represents the 2-character hexadecimal address of the analog input module.</p> <p>! is a delimiter character.</p> <p>v is the check sum/CRC status v=1 enable, v=0 disable.</p> <p>(cr) is the terminating character, carriage return (0Dh).</p>

10.4.2 \$AACRCv Set CRC

Description	The command will set the ASCII command check sum and modbus RTU CRC status.
Syntax	<p>\$AACRCv(cr)</p> <p># is a delimiter character.</p> <p>AA (range 00-FF) represents the 2-character hexadecimal address of an analog input module.</p> <p>CRC the ASCII protocol check sum and modbus RTU CRC status command</p> <p>v is the check sum/CRC status v=1 enable ,v=0 disable.</p> <p>(cr) is the terminating character, carriage return (0Dh).</p>
Response	<p>!AA(cr) if the command is valid or ?AA (cr) if the command is invalid</p> <p>There is no response if the module detects a syntax error or communication error.</p> <p>AA (range 00-FF) represents the 2-character hexadecimal address of the analog input module.</p> <p>! is a delimiter character.</p> <p>(cr) is the terminating character, carriage return (0Dh).</p>

10.4.3 \$AA5 Read The Reset status

Description	The command will read the module reset status.
Syntax	<p>\$AA5 (cr)</p> <p># is a delimiter character.</p> <p>AA (range 00-FF) represents the 2-character hexadecimal address of an analog input module.</p> <p>5 reads the module reset status command</p> <p>(cr) is the terminating character, carriage return (0Dh).</p>
Response	<p>!AAv(cr) if the command is valid or ?AA (cr) if the command is invalid</p> <p>There is no response if the module detects a syntax error or communication error.</p> <p>! is a delimiter character.</p> <p>AA (range 00-FF) represents the 2-character hexadecimal address of the analog input module.</p> <p>V reset status, v=0 no reset, v=1 reset at last once</p> <p>(cr) is the terminating character, carriage return (0Dh).</p> <p>Note: Reset status will be set to 0 after reading</p>

10.4.4 \$AAF Read The Firmware Version

Description	The command will read the module firmware version.
Syntax	<p>\$AAF(cr)</p> <p># is a delimiter character.</p> <p>AA (range 00-FF) represents the 2-character hexadecimal address of an analog input module.</p> <p>F read the module firmware version command</p> <p>(cr) is the terminating character, carriage return (0Dh).</p>
Response	<p>!AAnnnn(cr) if the command is valid or ?AA (cr) if the command is invalid</p> <p>There is no response if the module detects a syntax error or communication error.</p> <p>! is a delimiter character.</p> <p>AA (range 00-FF) represents the 2-character hexadecimal address of the analog input module.</p> <p>nnnn Firmware veion string (such as "M5.50")</p> <p>(cr) is the terminating character, carriage return (0Dh).</p>

10.4.5 \$AAGATE Read Gateway Address

Description	The command will read the module Gateway address.
Syntax	<p>\$AAGATE(cr)</p> <p># is a delimiter character.</p> <p>AA (range 00-FF) represents the 2-character hexadecimal address of an analog input module.</p> <p>GATE read the module Gateway address command</p> <p>(cr) is the terminating character, carriage return (0Dh).</p>
Response	<p>!AAnnnnnnnn(cr) if the command is valid or ?AA (cr) if the command is invalid</p> <p>There is no response if the module detects a syntax error or communication error.</p> <p>! is a delimiter character.</p> <p>AA (range 00-FF) represents the 2-character hexadecimal address of the analog input module.</p> <p>nnnnnnnn gateway address(8 digits) (such as C8A20001)</p> <p>(cr) is the terminating character, carriage return (0Dh).</p>

10.4.6 \$AAGATEnnnnnnnn Set Gateway Address

Description	The command will set the module Gateway address.
Syntax	<p>\$AAGATEnnnnnnnn (cr)</p> <p># is a delimiter character.</p> <p>AA (range 00-FF) represents the 2-character hexadecimal address of an analog input module.</p> <p>GATE set the module Gateway address command</p> <p>nnnnnnnn gateway address(8 digits) (such as C0A80001 =192.168.0.1)</p> <p>(cr) is the terminating character, carriage return (0Dh).</p>
Response	<p>!AA (cr) if the command is valid or ?AA (cr) if the command is invalid</p> <p>There is no response if the module detects a syntax error or communication error.</p> <p>! is a delimiter character.</p> <p>AA (range 00-FF) represents the 2-character hexadecimal address of the analog input module.</p> <p>(cr) is the terminating character, carriage return (0Dh).</p>

10.4.7 \$AAIP Read IP Address

Description	The command will set the module IP address.
Syntax	<p>\$AAGATEnnnnnnnn (cr) # is a delimiter character. AA (range 00-FF) represents the 2-character hexadecimal address of an analog input module. IP read the module IP address command (cr) is the terminating character, carriage return (0Dh).</p>
Response	<p>!AAnnnnnnnn (cr) if the command is valid or ?AA (cr) if the command is invalid There is no response if the module detects a syntax error or communication error. ! is a delimiter character. AA (range 00-FF) represents the 2-character hexadecimal address of the analog input module. nnnnnnnn IP address(8 digits) (such as C0A8000A =192.168.0.10) (cr) is the terminating character, carriage return (0Dh).</p>

10.4.8 \$AAIPnnnnnnnn Set IP Address

Description	The command will set the module IP address.
Syntax	<p>\$AAGATEnnnnnnnn (cr) # is a delimiter character. AA (range 00-FF) represents the 2-character hexadecimal address of an analog input module. IP set the module IP address command Nnnnnnnn IP address(8 digits) (such as C0A80001 =192.168.0.1) (cr) is the terminating character, carriage return (0Dh).</p>
Response	<p>!AA (cr) if the command is valid or ?AA (cr) if the command is invalid There is no response if the module detects a syntax error or communication error. ! is a delimiter character. AA (range 00-FF) represents the 2-character hexadecimal address of the analog input module. (cr) is the terminating character, carriage return (0Dh).</p>

10.4.9 \$AAM Reads The Module Name

Description	The command will read the module name.
Syntax	<p>\$AAM (cr) # is a delimiter character. AA (range 00-FF) represents the 2-character hexadecimal address of an analog input module. M read the module name command (cr) is the terminating character, carriage return (0Dh).</p>
Response	<p>!AA(name)(cr) if the command is valid or ?AA (cr) if the command is invalid There is no response if the module detects a syntax error or communication error. ! is a delimiter character. AA (range 00-FF) represents the 2-character hexadecimal address of the analog input module. name module name string (cr) is the terminating character, carriage return (0Dh).</p>

10.4.10 ~AAO(name) Set The Module Name

Description	The command will set module name
Syntax	~AA6(name)(cr) # is a delimiter character. AA (range 00-FF) represents the 2-character hexadecimal address of an analog input module. O set name command name 1~8 digits (cr) is the terminating character, carriage return (0Dh).
Response	!AA(cr) if the command is valid or ?AA (cr) if the command is invalid There is no response if the module detects a syntax error or communication error. ! is a delimiter character. AA (range 00-FF) represents the 2-character hexadecimal address of the analog input module. (cr) is the terminating character, carriage return (0Dh).
Example	Command : ~01Oabcdef(cr) Response : !01 (cr) The module name is "abcdef"

10.4.11 \$AAMASK Read Mask Address

Description	The command will read the module sub mask.
Syntax	\$AAMASK(cr) # is a delimiter character. AA (range 00-FF) represents the 2-character hexadecimal address of an analog input module. MASK read the module sub mask command (cr) is the terminating character, carriage return (0Dh).
Response	!AAnnnnnnnn(cr) if the command is valid or ?AA (cr) if the command is invalid There is no response if the module detects a syntax error or communication error. ! is a delimiter character. AA (range 00-FF) represents the 2-character hexadecimal address of the analog input module. nnnnnnnn sub mask (8 digits) (such as FFFFFFF00) (cr) is the terminating character, carriage return (0Dh).

10.4.12 \$AAMASKnnnnnnnn Set Mask Address

Description	The command will set the module sub mask.
Syntax	\$AAMASKnnnnnnnn(cr) # is a delimiter character. AA (range 00-FF) represents the 2-character hexadecimal address of an analog input module. MASK set the module sub mask command nnnnnnnn sub mask(8 digits) (such as FFFFFFF00=255.255.255.0) (cr) is the terminating character, carriage return (0Dh).
Response	!AA (cr) if the command is valid or ?AA (cr) if the command is invalid There is no response if the module detects a syntax error or communication error. ! is a delimiter character. AA (range 00-FF) represents the 2-character hexadecimal address of the analog input module. (cr) is the terminating character, carriage return (0Dh).

10.4.13 \$AAP Read The Communication Protocol

Description	The command will read communication protocol .
Syntax	\$AAP(cr) # is a delimiter character. AA (range 00-FF) represents the 2-character hexadecimal address of an analog input module. P read communication protocol command (cr) is the terminating character, carriage return (0Dh).
Response	!AA n(cr) if the command is valid or ?AA (cr) if the command is invalid There is no response if the module detects a syntax error or communication error. ! is a delimiter character. AA (range 00-FF) represents the 2-character hexadecimal address of the analog input module. n n=0 ASCII command protocol, n=1 ModBus RTU protocol (cr) is the terminating character, carriage return (0Dh).

10.4.14 \$AAPv Set The Communication Protocol

Description	The command will set communication protocol .
Syntax	\$AAPn(cr) # is a delimiter character. AA (range 00-FF) represents the 2-character hexadecimal address of an analog input module. P read communication protocol command n n=0 ASCII command protocol, n=1 ModBus RTU protocol (cr) is the terminating character, carriage return (0Dh).
Response	!AA(cr) if the command is valid or ?AA (cr) if the command is invalid There is no response if the module detects a syntax error or communication error. ! is a delimiter character. AA (range 00-FF) represents the 2-character hexadecimal address of the analog input module. (cr) is the terminating character, carriage return (0Dh).

10.4.15 \$AASW Read Web Server Status

Description	The command will read web server status.
Syntax	\$AASW(cr) # is a delimiter character. AA (range 00-FF) represents the 2-character hexadecimal address of an analog input module. WEB read we server enable/disable status (cr) is the terminating character, carriage return (0Dh).
Response	!AA n(cr) if the command is valid or ?AA (cr) if the command is invalid There is no response if the module detects a syntax error or communication error. ! is a delimiter character. AA (range 00-FF) represents the 2-character hexadecimal address of the analog input module. n Web server status, n=0 disable, n=1 enable (cr) is the terminating character, carriage return (0Dh).

10.4.16 \$AASWv Enabled/Disable Web Server

Description	The command will enable/disable web server.
Syntax	\$AASWn(cr) # is a delimiter character. AA (range 00-FF) represents the 2-character hexadecimal address of an analog input module. WEB enable/disable web server command n Web server status, n=0 disable, n=1 enable (cr) is the terminating character, carriage return (0Dh).
Response	!AA(cr) if the command is valid or ?AA (cr) if the command is invalid There is no response if the module detects a syntax error or communication error. ! is a delimiter character. AA (range 00-FF) represents the 2-character hexadecimal address of the analog input module. (cr) is the terminating character, carriage return (0Dh).

10.4.17 \$AADHCP Read DHCP Status

Description	The command will read DHCP status.
Syntax	\$AADHCP(cr) # is a delimiter character. AA (range 00-FF) represents the 2-character hexadecimal address of an analog input module. DHCP read DHCP enable/disable status (cr) is the terminating character, carriage return (0Dh).
Response	!AA n(cr) if the command is valid or ?AA (cr) if the command is invalid There is no response if the module detects a syntax error or communication error. ! is a delimiter character. AA (range 00-FF) represents the 2-character hexadecimal address of the analog input module. n DHCP status=0 disable, n=1 enable (cr) is the terminating character, carriage return (0Dh).

10.4.18 \$AADHCPv Enabled/Disable DHCP

Description	The command will enable/disable DHCP.
Syntax	\$AASWn(cr) # is a delimiter character. AA (range 00-FF) represents the 2-character hexadecimal address of an analog input module. WEB enable/disable web server command n enable/disable DHCP ,n=0 disable, n=1 enable (cr) is the terminating character, carriage return (0Dh).
Response	!AA(cr) if the command is valid or ?AA (cr) if the command is invalid There is no response if the module detects a syntax error or communication error. ! is a delimiter character. AA (range 00-FF) represents the 2-character hexadecimal address of the analog input module. (cr) is the terminating character, carriage return (0Dh).

10.4.19 ^AAMAC Read MAC Address

Description	The command will read MAC Address.
Syntax	^AAMAC(cr) ^ is a delimiter character. AA (range 00-FF) represents the 2-character hexadecimal address of an analog input module. MAC read Read MAC Address (cr) is the terminating character, carriage return (0Dh).
Response	!AA(nnnnnnnnnn)(cr) if the command is valid or ?AA (cr) if the command is invalid There is no response if the module detects a syntax error or communication error. ! is a delimiter character. AA (range 00-FF) represents the 2-character hexadecimal address of the analog input module. nnnnnnnnnnn MAC Address (cr) is the terminating character, carriage return (0Dh).

10.4.20 ~AA6v Set Module Led Control

Description	The command will Set Module Led Control.
Syntax	~AA6v(cr) # is a delimiter character. AA (range 00-FF) represents the 2-character hexadecimal address of an analog input module. 6 set module Led control command v LED control mode v="H" controlled by host, v="M" controlled by module n enable/disable DHCP ,n=0 disable, n=1 enable (cr) is the terminating character, carriage return (0Dh).
Response	!AA(cr) if the command is valid or ?AA (cr) if the command is invalid There is no response if the module detects a syntax error or communication error. ! is a delimiter character. AA (range 00-FF) represents the 2-character hexadecimal address of the analog input module. (cr) is the terminating character, carriage return (0Dh).

10.4.21 ~AA6ddddddd Write Data To Led Board

Description	The command will Write Data To Led Board.
Syntax	~AA6ddddddd(cr) # is a delimiter character. AA (range 00-FF) represents the 2-character hexadecimal address of an analog input module. 6 set module Led control command ddddddd 6 digits (32-bits) LED data n enable/disable DHCP ,n=0 disable, n=1 enable (cr) is the terminating character, carriage return (0Dh).
Response	!AA(cr) if the command is valid or ?AA (cr) if the command is invalid There is no response if the module detects a syntax error or communication error. ! is a delimiter character. AA (range 00-FF) represents the 2-character hexadecimal address of the analog input module. (cr) is the terminating character, carriage return (0Dh).

10.4.22 ~AA6ddddddnnnn Force Led To Flash

Description	The command will force Led to flash for the specified times
Syntax	~AA6ddddddnnnn(cr) # is a delimiter character. AA (range 00-FF) represents the 2-character hexadecimal address of an analog input module. 6 set module Led control command ddddddd 6 digits (32-LED channels, bit n=1 enable LED channel n flash) nnnn flash times (0000~FFFF) (cr) is the terminating character, carriage return (0Dh).
Response	!AA(cr) if the command is valid or ?AA (cr) if the command is invalid There is no response if the module detects a syntax error or communication error. ! is a delimiter character. AA (range 00-FF) represents the 2-character hexadecimal address of the analog input module. (cr) is the terminating character, carriage return (0Dh).

10.4.23 ~AA3ettttddd Write Communication Timeout settings

Description	Enable/disable Communication timeout watchdog, set timeout period and power-on delay time
Syntax	~AA3ettttddd(cr) ~ Is a delimiter character. AA (range 00-FF) represents the 2-character hexadecimal address of module. 3 is the set communication timeout command e Enable/disable communication timeout watchdog, e=0 disable=1 enable tttt (range 0000~FFFF) Communication timeout period (msec) dddd (range 0000~FFFF) Power-on delay time (msec) to start Communication timeout watchdog (cr) Is the terminating character, carriage return (0Dh).
Response	!AA(cr) If the command is valid or ?AA (cr) if the command is invalid There is no response if the module detects a syntax error or communication error. ! Is a delimiter character. AA (range 00-3F) represents the 2-character hexadecimal address of module. (cr) Is the terminating character, carriage return (0Dh)
Example	Command : ~013100FF01FF(cr) Response : !01(cr) The command set communication timeout period=00FF msec and power-on delay time=1FF msec, and enable communication timeout watchdog. The DO channels will be set to DO safe value when compunction timeout occurred
Example	Command : ~013000FF01FF(cr) Response : !01(cr) The command to disable communication timeout watchdog.

10.4.24 ~AA3 Read Communication Timeout settings

Description	Read Communication timeout watchdog status, communication timeout period, and power-on delay time
Syntax	~AA3etttddd(cr) ~ Is a delimiter character. AA (range 00-FF) represents the 2-character hexadecimal address of module. 3 is the set communication timeout command (cr) Is the terminating character, carriage return (0Dh).
Response	!AAetttddd(cr) If the command is valid or ?AA (cr) if the command is invalid There is no response if the module detects a syntax error or communication error. ! Is a delimiter character. AA (range 00-3F) represents the 2-character hexadecimal address of module. (cr) Is the terminating character, carriage return (0Dh) e communication timeout watchdog status, e=0 disable. e=1 enable tttt (range 0000~FFFF) Communication timeout period (msec) dddd (range 0000~FFFF) Power-on delay time (msec) to start Communication timeout watchdog (cr) Is the terminating character, carriage return (0Dh).
Example	Command : ~013(cr) Response : !01100FF01FF(cr) The communication timeout watchdog is enabled, timeout period=00FF (msec),power-on delay time=01FF (msec)

10.4.25 #AA Read The Analog Inputs Of All

Description	The command will return the input value from a specified (AA) module in the currently configured data format.
Syntax	#AA(cr) # Is a delimiter character. AA (range 00-FF) represents the 2-character hexadecimal address of an analog input module. (cr) Is the terminating character, carriage return (0Dh).
Response	>(data)(cr) If the command is valid or ?AA (cr) if the command is invalid There is no response if the module detects a syntax error or communication error. > Is a delimiter character. (data) Is the input value in the configured data format of the module (cr) Is the terminating character, carriage return (0Dh)
Example	Command : #21(cr) Response : >+7.2111+7.2567+7.3125+7.1000+7.4712+7.2555+7.1234+7.5678+7.2111+7.2567+7.3125 +7.1000+7.4712+7.2555+7.1234+7.5678 +3.5678 (cr) The command response the analog input module at address 21h for its input values of all channels. The analog input module responds with channels from 0 to 15 with +7.2111 volts, +7.2567 volts,+7.3125 volts, +7.1000 volts, +7.4712 volts, +7.2555 volts, +7.1234 volts ,+7.5678 volts,+7.2111 volts, +7.2567 volts,+7.3125 volts, +7.1000 volts, +7.4712 volts, +7.2555 volts, +7.1234 volts and +7.5678 volts. The average value is +3.5678 volts
Example	Command : #01(cr) Response : >FF5DE4323212AE3323345663E000FF03FF5DE4323212AE3323345663E000FF03FE02 (cr) The analog input module at address01 has an input value of FF5DE4323212AE3323345663E000FF03FF5DE4323212AE3323345663E000FF03FE02. (The configured data format of the analog input module is two's complement)Where FE02 is the average value

10.4.26 #AAn Read The Single Analog Input

Description	The command will return the input value from one of the all channels of a specified (AA) module in the currently configured data format.
Syntax	#AAN(cr) # Is a delimiter character. AA (range 00-3F) represents the 2-character hexadecimal address of the analog input module. N Identifies the channel you want to read. The value can range from 0 to F
Response	(cr) Is the terminating character, carriage return (0Dh). >(data)(cr) If the command is valid or ?AA (cr) if the command is invalid There is no response if the module detects a syntax error or communication error. > Is a delimiter character. (data) Is the input value of the channel number N. Data consists of a + or - sign followed by five decimal digits with a fixed decimal point. (cr) Is the terminating character, carriage return (0Dh).
Example	Command : #120(cr) Response : >+1.4567(cr) The command requests the analog input module at address 12h to return the input value of channel 0. The analog input module responds that the input value of channel 0 is equal to +1.4567 volts.

10.4.27 #AAMH Read Maximum Value Of All Channels

Description	The command will return the Read Maximum Value of All Channels from a specified (AA) module in the currently configured data format.
Syntax	#AAMH(cr) # is a delimiter character. AA (range 00-FF) represents the 2-character hexadecimal address of an analog input module. MH Read all channel maximum value command
Response	(cr) is the terminating character, carriage return (0Dh). >AA(data)(cr) if the command is valid or ?AA (cr) if the command is invalid There is no response if the module detects a syntax error or communication error. AA (range 00-FF) represents the 2-character hexadecimal address of the analog input module. > is a delimiter character. (data) is the Maximum value of all channels in the configured data format of the module. (cr) is the terminating character, carriage return (0Dh).
Example	Command : #21MH(cr) Response : !21+7.2111+7.2567+7.3125+7.1000+7.4712+7.2555+7.1234+7.5678+7.2111 +7.2567+7.3125+7.1000+7.4712+7.2555+7.1234+7.5678 (cr) The command response the analog input module at address 21h for its maximum values of all channels. The analog input module responds its maximum values with channels from 0 to 15 with +7.2111 volts, +7.2567 volts, +7.3125 volts, +7.1000 volts, +7.4712 volts, +7.2555 volts, +7.1234 volts, +7.5678 volts, +7.2111 volts, +7.2567 volts, +7.3125 volts, +7.1000 volts, +7.4712 volts, +7.2555 volts, +7.1234 volts and +7.5678 volts
Example	Command : #01MH(cr) Response : !01FF5DE4323212AE3323345663E000FF03 F5DE4323212AE3323345663E000FF03 (cr) The analog input module at address01 has maximum values of FF5DE4323212AE3323345663E000FF03FF5DE4323212AE3323345663E000FF03. (The configured data format of the analog input module is two's complement)

10.4.28 #AAMHn Read Maximum Value Of Specified Channel

Description	The command will return the Read Maximum value of the specified channel from a specified (AA) Module in the currently configured data format.
Syntax	#AAMHn(cr) # is a delimiter character. AA (range 00-FF) represents the 2-character hexadecimal address of an analog input module. MH Read single channel maximum value command N channel number (cr) is the terminating character, carriage return (0Dh).
Response	>AA(data)(cr) if the command is valid or ?AA (cr) if the command is invalid There is no response if the module detects a syntax error or communication error. AA (range 00-FF) represents the 2-character hexadecimal address of the analog input module. > is a delimiter character. (data) is the Maximum value of the specified channels. (cr) is the terminating character, carriage return (0Dh).
Example	Command : #21MH2(cr) Response : !21+7.2111(cr) The command response the analog input module at address 21h for its maximum values of the channels 2 with +7.2111 volts
Example	Command : #01MH2(cr) Response : !01FF5D (cr) The command response the analog input module at address 21h for its maximum values of the channels 2 with FF5D (The configured data format of the analog input module is two's complement)

10.4.29 \$AAMH Clear All Maximum Value

Description	Clear maximum Value Of all channels
Syntax	\$AAMH(cr) \$ is a delimiter character. AA (range 00-FF) represents the 2-character hexadecimal address of module. MH is the clear maximum value of specified channel command. (cr) is the terminating character, carriage return (0Dh).
Response	!AA(cr) if the command is valid or ?AA (cr) if the command is invalid. There is no response if the module detects a syntax error or communication error. ! Delimiter character indicates a valid command was received. ? Delimiter character indicates the command was invalid. AA (range 00-3F) represents the 2-character hexadecimal address of module. (cr) is the terminating character, carriage return (0Dh).
Example	Command : \$01MH(cr) Response : !01(cr) Clear Maximum Value Of all Channels

10.4.30 \$AAMHn Clear Maximum Value Of Specified Channel

Description	Clear maximum Value Of specified channel
Syntax	\$AAMHn(cr) \$ is a delimiter character. AA (range 00-FF) represents the 2-character hexadecimal address of module. MH is the clear maximum value of specified channel command. n channel 0~15 (cr) is the terminating character, carriage return (0Dh).
Response	!AA(cr) if the command is valid or ?AA (cr) if the command is invalid. There is no response if the module detects a syntax error or communication error. ! Delimiter character indicates a valid command was received. ? Delimiter character indicates the command was invalid. AA (range 00-3F) represents the 2-character hexadecimal address of module. (cr) is the terminating character, carriage return (0Dh).
Example	Command : \$01MHE(cr) Response : !01(cr) Clear Maximum Value Of Channel 14 (0x0E)

10.4.31 #AAML Read Minimum Value Of All Channels

Description	The command will return the Read Minimum Value of All Channels from a specified (AA) Module in the currently configured data format.
Syntax	#AAML(cr) # is a delimiter character. AA (range 00-FF) represents the 2-character hexadecimal address of an analog input module. ML Read all channel minimum value command (cr) is the terminating character, carriage return (0Dh).
Response	>AA(data)(cr) if the command is valid or ?AA (cr) if the command is invalid There is no response if the module detects a syntax error or communication error. AA (range 00-FF) represents the 2-character hexadecimal address of the analog input module. > is a delimiter character. (data) is the minimum value of all channels in the configured data format of the module. (cr) is the terminating character, carriage return (0Dh).
Example	Command : #21ML(cr) Response : !21+7.2111+7.2567+7.3125+7.1000+7.4712+7.2555+7.1234+7.5678+7.2111+7.2567+7.3125+7.1000+7.4712+7.2555+7.1234+7.5678 (cr) The command response the analog input module at address 21h for its minimum values of all channels. The analog input module responds its minimum values with channels from 0 to 15 with +7.2111 volts, +7.2567 volts, +7.3125 volts, +7.1000 volts, +7.4712 volts, +7.2555 volts, +7.1234 volts, +7.5678 volts, +7.2111 volts, +7.2567 volts, +7.3125 volts, +7.1000 volts, +7.4712 volts, +7.2555 volts, +7.1234 volts and +7.5678 volts
Example	Command : #01ML(cr) Response : !01FF5DE4323212AE3323345663E000FF03F5DE4323212AE3323345663E000FF03(cr) The analog input module at address 01 has minimum values of FF5DE4323212AE3323345663E000FF03FF5DE4323212AE3323345663E000FF03. (The configured data format of the analog input module is two's complement)

10.4.32 #AAMLn Read Minimum Value Of Specified Channel

Description	The command will return the read minimum value of the specified channel from a specified (AA) Module in the currently configured data format.
Syntax	#AAMLn(cr) # is a delimiter character. AA (range 00-FF) represents the 2-character hexadecimal address of an analog input module. ML read single channel maximum value command N channel number (cr) is the terminating character, carriage return (0Dh).
Response	>AA(data)(cr) if the command is valid or ?AA (cr) if the command is invalid There is no response if the module detects a syntax error or communication error. AA (range 00-FF) represents the 2-character hexadecimal address of the analog input module. > is a delimiter character. (data) is the minimum value of the specified channels. (cr) is the terminating character, carriage return (0Dh).
Example	Command : #21ML2(cr) Response : !21+7.2111(cr) The command response the analog input module at address 21h for its minimum values of the channels 2 with +7.2111 volts
Example	Command : #01ML2(cr) Response : !01FF5D (cr) The command response the analog input module at address 21h for its minimum values of the channels 2 with FF5D (The configured data format of the analog input module is two's complement)

10.4.33 \$AAML Clear All Minimum Value

Description	Clear minimum Value Of all channels
Syntax	\$AAML(cr) \$ is a delimiter character. AA (range 00-3F) represents the 2-character hexadecimal address of module. ML is the clear minimum value of all channels command. (cr) is the terminating character, carriage return (0Dh).
Response	!AA(cr) if the command is valid or ?AA (cr) if the command is invalid. There is no response if the module detects a syntax error or communication error. ! Delimiter character indicates a valid command was received. ? Delimiter character indicates the command was invalid. AA (range 00-3F) represents the 2-character hexadecimal address of module. (cr) is the terminating character, carriage return (0Dh).
Example	Command : \$01ML(cr) Response : !01(cr) Clear Minimum Value Of all Channels

10.4.34 \$AAMLn Clear Minimum Value Of Specified Channel

Description	Clear Minimum Value Of specified Channel
Syntax	<p>\$AAMLn(cr)</p> <p>\$ is a delimiter character.</p> <p>AA (range 00-3F) represents the 2-character hexadecimal address of module.</p> <p>ML is the clear minimum value of all channels command.</p> <p>n channel 0~15</p> <p>(cr) is the terminating character, carriage return (0Dh).</p>
Response	<p>!AA(cr) if the command is valid or ?AA (cr) if the command is invalid.</p> <p>There is no response if the module detects a syntax error or communication error.</p> <p>! Delimiter character indicates a valid command was received.</p> <p>? Delimiter character indicates the command was invalid.</p> <p>AA (range 00-3F) represents the 2-character hexadecimal address of module.</p> <p>(cr) is the terminating character, carriage return (0Dh).</p>
Example	<p>Command : \$01MLE(cr)</p> <p>Response : !01(cr)</p> <p>Clear Minimum Value of Channel 14 (0x0E)</p>

10.4.35 #AAV Read Average Value

Description	The command will return the average value from the channels which is in average mode
Syntax	<p>#AAV(cr)</p> <p># is a delimiter character.</p> <p>AA (range 00-3F) represents the 2-character hexadecimal address of the analog input module.</p> <p>V identifies Read Ad average value command</p> <p>(cr) is the terminating character, carriage return (0Dh).</p>
Response	<p>>(data)(cr) if the command is valid or ?AA (cr) if the command is invalid</p> <p>There is no response if the module detects a syntax error or communication error.</p> <p>! is a delimiter character.</p> <p>The command requests the analog input module at address 12h to return the input value of channel 0. The analog input module responds that the input value of channel 0 is equal to +1.4567 volts.</p>
Example	<p>Command : #12V(cr)</p> <p>Response : >+1.4567(cr)</p> <p>The command requests the analog input module at address 12h to return the average value of the module. The analog input module responds that the average value of module is equal to +1.4567 volts.</p>

10.4.36 \$AAE Read Channel Average Enable/Disable Status

Description	Read A/D channel in average status
Syntax	<p>\$AAE(cr)</p> <p>\$ is a delimiter character.</p> <p>AA (range 003F) represents the 2-character hexadecimal address of module.</p> <p>E is Read A/D channel in average status command.</p> <p>(cr) is the terminating character, carriage return (ODh).</p>
Response	<p>!AAnnnn(cr) if the command is valid or ?</p> <p>AA (cr) if the command is invalid.</p> <p>There is no response if the module detects a syntax error or communication error.</p> <p>! is a delimiter character indicating a valid command was received.</p> <p>AA (range 00-3F) represents the 2-character hexadecimal address of module.</p> <p>nnnn are four hexadecimal values. The values are interpreted by the module as four binary words(4-bit). The first word represents channel 12~15, and the second word represents channel 8~11...etc.</p> <p>bit x=1 channel x is in average, bit x=0 channel isn't in average</p> <p>(cr) is the terminating character, carriage return</p>
Examples	<p>Command : \$01E(cr)</p> <p>Response : !011020 (cr)</p> <p>Channel 5 and channel 15 are in average only</p>

10.4.37 \$AAEnnn Disable/Enable Channel in Average

Description	Enables/disables channels to be in average mode.
Syntax	<p>\$AAEvvvv(cr)</p> <p>\$ is a delimiter character.</p> <p>AA (range 00-FF) represents the 2-character hexadecimal address of module.</p> <p>E is the Enable/disable channels to be in average command.</p> <p>vvvv are four hexadecimal values. The values are interpreted by the module as four binary words (4-bit). The first word represents the status of channel 12~15, and the second word represents the status of channel 8~11...etc.</p> <p>Value 0 means enable channel to be in average, value 1 means disable channel to be not in average.</p>
Response	<p>(cr) is the terminating character, carriage return (0Dh).</p> <p>!AA(cr) if the command is valid or ?</p> <p>AA (cr) if the command is invalid.</p> <p>There is no response if the module detects a syntax error or communication error.</p> <p>! Delimiter character indicates a valid command was received.</p> <p>? Delimiter character indicates the command was invalid.</p> <p>AA (range 00-3F) represents the 2-character hexadecimal address of module.</p> <p>(cr) is the terminating character, carriage return (0Dh).</p>
Example	<p>Command : \$01E0103(cr)</p> <p>Response : !01(cr)</p> <p>Hexadecimal 0103 equals binary <u>0000 0001 0000 0011</u>, which enables channel 0, 1 and 8 to be in average mode only</p>

10.4.38 #AAAL Read AD High/Low Alarm Status

Description	The command will return the alarm status from all channels of a specified (AA) module.
Syntax	<p>#AAAL(cr)</p> <p># is a delimiter character.</p> <p>AA (range 00-FF) represents the 2-character hexadecimal address of the analog input module.</p> <p>AL identifies Read Ad high/low Alarm Status command</p> <p>(cr) is the terminating character, carriage return (0Dh).</p>
Response	<p>!AA(hhhh)(llll)(cr) if the command is valid or ? AA (cr) if the command is invalid</p> <p>There is no response if the module detects a syntax error or communication error.</p> <p>! is a delimiter character.</p> <p>Hhhh are four hexadecimal values. The values are interpreted by the module as four binary words (4-bit). The first word represents the status of channel 12~15, and the second word represents the status of channel 8~11...etc.</p> <p>bit x=0 means the channel x is high alarm, bit x= 1 means the channel x isn't high alarm.</p> <p>(cr) is the terminating character, carriage return (0Dh).</p> <p>llll Are four hexadecimal values. The values are interpreted by the module as four binary words (4-bit). The first word represents the status of channel 12~15, and the second word represents the status of channel 8~11...etc.</p> <p>bit x=0 means the channel x is low alarm, bit x= 1 means the channel x isn't low alarm.</p>
Example	<p>Command : #01AL(cr)</p> <p>Response : !0100010010(cr)</p> <p>The command requests the analog input module at address 12h to return the alarm status of all channels.</p> <p>The analog input module responds that the alarm value of all channels is equal to 00010010 (hex)</p> <p>The high alarm status=0001 means the channel 0 is high alarm</p> <p>The low alarm status=0010 means the channel 4 is low alarm</p>

10.4.39 \$AAAHnnnn Clear A/D High Alarm

Description	Clear A/D High Alarm status (over range status).
Syntax	<p>\$AAAHnnnn (cr)</p> <p>\$ is a delimiter character.</p> <p>AA (range 003F) represents the 2-character hexadecimal address of module.</p> <p>H is the clear high alarm command.</p> <p>nnnn are four hexadecimal values. The values are interpreted by the module as four binary words (4-bit). The first word represents channel 12~15, and the second word represents channel 8~11...etc.</p> <p>bit x=1 clear high alarm status of channel x, bit x=0 no clear</p> <p>(cr) is the terminating character, carriage return (0Dh).</p>
Response	<p>!AA(cr) if the command is valid or ?AA (cr) if the command is invalid.</p> <p>There is no response if the module detects a syntax error or communication error.</p> <p>! is a delimiter character indicating a valid command was received.</p> <p>AA (range 00-3F) represents the 2-character hexadecimal address of module.</p> <p>(cr) is the terminating character, carriage return</p>
Examples	<p>Command : \$01H0101(cr)</p> <p>Response : !01 (cr)</p> <p>Clear high alarm status of channel 0 and 4</p>

10.4.40 \$AAALnnnn Clear A/D Low Alarm

Description	Clear A/D high alarm status (under range status).
Syntax	<p>\$AAALnnnn (cr)</p> <p>\$ is a delimiter character.</p> <p>AA (range 003F) represents the 2-character hexadecimal address of module.</p> <p>L is the clear high alarm command.</p> <p>nnnn are four hexadecimal values. The values are interpreted by the module as four binary words (4-bit). The first word represents channel 12~15, and the second word represents channel 8~11...etc.</p> <p>bit x=1 clear low alarm status of channel x, bit x=0 no clear</p> <p>(cr) is the terminating character, carriage return (ODh).</p>
Response	<p>!AA(cr) if the command is valid or ?AA (cr) if the command is invalid.</p> <p>There is no response if the module detects a syntax error or communication error.</p> <p>! Is a delimiter character indicating a valid command was received.</p> <p>AA (range 00-3F) represents the 2-character hexadecimal address of module.</p> <p>(cr) is the terminating character, carriage return</p>
Examples	<p>Command : \$01L0101(cr)</p> <p>Response : !01 (cr)</p> <p>Clear low alarm status of channel 0 and 4</p>

10.4.41 \$AAB Read Channel Burnout Status

Description	Read channel burn out status
Syntax	<p>\$AAB(cr)</p> <p>\$ is a delimiter character.</p> <p>AA (range 00-3F) represents the 2-character hexadecimal address of module.</p> <p>B is the Channel Diagnose command.</p> <p>(cr) is the terminating character, carriage return (0Dh).</p>
Response	<p>!AAnnnn(cr) if the command is valid</p> <p>?AA(cr) if an invalid command was issued.</p> <p>There is no response if the module detects a syntax error or communication error.</p> <p>! Delimiter character indicates a valid command was received.</p> <p>? Delimiter character indicates the command was invalid.</p> <p>AA (range 00-3F) represents the 2-character hexadecimal address of the module.</p> <p>Nnnn (range 0000-FFFF) is a hexadecimal number that equals the 16-bit parameter, representing the status of analog input channels. Bit value 0 means normal status; and bit value 1 means channel open wiring.</p> <p>(cr) is the terminating character, carriage return (0Dh)</p>
Examples	<p>Command : \$01B(cr)</p> <p>Response : !010101(cr)</p> <p>Channel 0, 8 are open wiring and channel 1~7 and 9~15 are all normal.</p>

10.4.42 %AAB Read Channel Burnout Enable/Disable Status

Description	Read channel burnout detection enables/disables status of a specified input module.
Syntax	%AAB(cr) % is a delimiter character. AA (range 00-3F) represents the 2-character hexadecimal address of module. B is the Enable/disable burnout command. (cr) is the terminating character, carriage return (0Dh).
Response	!AAbb(cr) if the command is valid or ?AA (cr) if the command is invalid. There is no response if the module detects a syntax error or communication error. ! Delimiter character indicates a valid command was received. ? Delimiter character indicates the command was invalid. AA (range 00-3F) represents the 2-character hexadecimal address of module. B burnout enable/disable status, 0: disable, 1: enable (cr) is the terminating character, carriage return (0Dh).
Example	Command : %01B(cr) read burnout detection enable/disable status of specified module Response : !001(cr) burnout detection is enabled
Example	Command : %01B(cr) read burnout detection enable/disable status of specified module Response : !001(cr) burnout detection is enabled

10.4.43 %AABn Enable/Disable Burnout Detection

Description	Enables/disables channel burnout detection of a specified input module.
Syntax	%AABn(cr) % is a delimiter character. AA (range 00-3F) represents the 2-character hexadecimal address of module. B is the Enable/disable burnout command. n represents enable or disable burnout, value 1 means enable burnout detection, value 0 means disable burnout detection. (cr) is the terminating character, carriage return (0Dh).
Response	!AA(cr) if the command is valid or ?AA (cr) if the command is invalid. There is no response if the module detects a syntax error or communication error. ! Delimiter character indicates a valid command was received. ? Delimiter character indicates the command was invalid. AA (range 00-3F) represents the 2-character hexadecimal address of module. (cr) is the terminating character, carriage return (0Dh).
Example	Command : %00B1(cr) this command enable burnout detection of specified module Response : !00(cr) this command disable burnout detection of specified module
Example	Command : %00B0(cr) Response : !00(cr)

10.4.44 \$AA3 Read The CJC Temperature

Description	Read cold junction temperature.
Syntax	<p>\$AA3(cr)</p> <p>\$ is a delimiter character.</p> <p>AA (range 00-3F) represents the 2-character hexadecimal address of module.</p> <p>3 is the Read cold junction temperature command.</p> <p>(cr) is the terminating character, carriage return (0Dh).</p>
Response	<p>>DATA(cr) if the command is valid or ?AA (cr) if the command is invalid.</p> <p>There is no response if the module detects a syntax error or communication error.</p> <p>> Delimiter character indicates a valid command was received.</p> <p>? Delimiter character indicates the command was invalid.</p> <p>DATA CJC temperature in degrees Celsius, consisting of of a sign byte, '+' or '-' and followed by 5 decimal digits with a fixed decimal point in tenth of a degree</p> <p>(cr) is the terminating character, carriage return (0Dh).</p>
Example	<p>Command : \$043(cr)</p> <p>Response : >+0030.2(cr)</p> <p>The command asks the analog input module at address 04h to send its cold junction temperature data. The module responds with +0030.2C.</p>

10.4.45 ~AAC Read The CJC Enable/Disable

Description	read cold junction compensation enable/disable status.
Syntax	<p>~AAC(cr)</p> <p>~ is a delimiter character.</p> <p>AA (range 00-3F) represents the 2-character hexadecimal address of module.</p> <p>C read CJC enable/disable status command.</p> <p>(cr) is the terminating character, carriage return (0Dh).</p>
Response	<p>!AA n if the command is valid or ?AA (cr) if the command is invalid.</p> <p>There is no response if the module detects a syntax error or communication error.</p> <p>! is a delimiter character indicating a valid command was received.</p> <p>AA (range 00-3F) represents the 2-character hexadecimal address of module.</p> <p>N n=1 if CJC enabled, n=0 if CJC disabled</p> <p>(cr) is the terminating character, carriage return</p>
Examples	<p>Command : ~01C(cr)</p> <p>Response : !011(cr)</p> <p>CJC for all channels is enabled</p>

10.4.46 ~AACn Enable/Disable The CJC

Description	enable/disable cold junction compensation.
Syntax	~AACn(cr) ~ is a delimiter character. AA (range 00-3F) represents the 2-character hexadecimal address of module. C is the enable/disable CJC command. N =0 disable CJC, n=1 enable CJC (cr) is the terminating character, carriage return (ODh).
Response	!AA if the command is valid or ?AA (cr) if the command is invalid. There is no response if the module detects a syntax error or communication error. ! is a delimiter character indicating a valid command was received. AA (range 00-FF) represents the 2-character hexadecimal address of module. (cr) is the terminating character, carriage return
Examples	Command : ~01C1(cr) Response : !01(cr) Noble cold junction compensation

10.4.47 \$AA9snnnn Set The All Channel CJC Offset

Description	Set all channels to have the same cold junction offset.
Syntax	\$AA9snnnn(cr) \$ is a delimiter character. AA (range 00-3F) represents the 2-character hexadecimal address of module. 9 is the set cold junction offset command. S sign of cold junction offset nnnn cold junction offset (Hex) in 0.01C unit (cr) is the terminating character, carriage return (ODh).
Response	!AA If the command is valid or ?AA (cr) if the command is invalid. There is no response if the module detects a syntax error or communication error. ! is a delimiter character indicating a valid command was received. AA (range 00-3F) represents the 2-character hexadecimal address of module. (cr) is the terminating character, carriage return
Examples	Command : \$019+0010(cr) Response : !01(cr) Set all channels to have the same cold junction offset to +0010(Hex)*0.01=+0.16C.

10.4.48 \$AA9c Read Single Channel CJC Offset

Description	read cold junction offset of specified channel
Syntax	<p>\$AA9c(cr) \$ is a delimiter character. AA (range 00-3F) represents the 2-character hexadecimal address of module. 9 is the set cold junction offset command. C channel number (cr) is the terminating character, carriage return (ODh).</p>
Response	<p>!AAsnnnn if the command is valid or ?AA (cr) if the command is invalid. There is no response if the module detects a syntax error or communication error. ! Is a delimiter character indicating a valid command was received. AA (range 00-3F) represents the 2-character hexadecimal address of module. S sign of cold junction offset nnnn cold junction offset in 0.01C unit (cr) is the terminating character, carriage return</p>
Examples	<p>Command : \$0192(cr) Response : !01+0010(cr) The cold junction offset of channel 2 is +0010(Hex)*0.01=+0.16C. Response : !AA if the command is valid or ?AA (cr) if the command is invalid. There is no response if the module detects a syntax error or communication error. ! is a delimiter character indicating a valid command was received. AA (range 00-3F) represents the 2-character hexadecimal address of module. (cr) is the terminating character, carriage return</p>
Examples	<p>Command : \$019+0010(cr) Response : !01(cr) Set all channels to have cold junction offset to +0010(Hex)*0.01=+0.16C.</p>

10.4.49 \$AA9cSnnnn Set Single Channel CJC Offset

Description	set channel cold junction offset individually
Syntax	<p>\$AA9csnnnn(cr) \$ is a delimiter character. AA (range 00-3F) represents the 2-character hexadecimal address of module. 9 is the set cold junction offset command. c is the channel number (0~F) s sign of cold junction offset nnnn cold junction offset (Hex) in 0.01C unit (cr) is the terminating character, carriage return (ODh).</p>
Response	<p>!AA if the command is valid or ?AA (cr) if the command is invalid. There is no response if the module detects a syntax error or communication error. ! Is a delimiter character indicating a valid command was received. AA (range 00-3F) represents the 2-character hexadecimal address of module. (cr) is the terminating character, carriage return</p>
Examples	<p>Command : \$0193+0010(cr) Response : !01(cr) Set cold junction offset to +0010(Hex)*0.01=+0.16C to channel 3</p>

10.4.50 \$AAR Read AD Filter Value

Description	Read A/D cutoff frequency
Syntax	\$AAR(cr) \$ is a delimiter character. AA (range 00-3F) represents the 2-character hexadecimal address of module. R read A/D cutoff frequency command. (cr) is the terminating character, carriage return (ODh).
Response	!AA n if the command is valid or ?AA (cr) if the command is invalid. There is no response if the module detects a syntax error or communication error. ! is a delimiter character indicating a valid command was received. AA (range 00-3F) represents the 2-character hexadecimal address of module. n 0: 50Hz, 1:60Hz, 2:100Hz, 3:120Hz (cr) is the terminating character, carriage return
Examples	Command : \$01R(cr) Response : !011(cr) A/D cutoff frequency is 60Hz

10.4.51 \$AARf Set AD Filter Value

Description	Set A/D cutoff frequency
Syntax	\$AARf(cr) \$ is a delimiter character. AA (range 00-3F) represents the 2-character hexadecimal address of module. R read A/D cutoff frequency command. f 0: 50Hz, 1:60Hz, 2:100Hz, 3:120Hz (cr) is the terminating character, carriage return (ODh).
Response	!AA n if the command is valid or ?AA (cr) if the command is invalid. There is no response if the module detects a syntax error or communication error. ! is a delimiter character indicating a valid command was received. AA (range 00-3F) represents the 2-character hexadecimal address of module. (cr) is the terminating character, carriage return
Examples	Command : \$01R0(cr) Response : !011(cr) Set A/D cutoff frequency to 560Hz

10.4.52 \$AA6 Read the Channel Enable/Disable Status

Description	Read the status of digital input/output channels
Syntax	<p>\$AA6(cr)</p> <p>\$ is a delimiter character.</p> <p>AA represents the 2-character hexadecimal module address</p> <p>6 is the Digital Data In command.</p> <p>(cr) is the terminating character, carriage return (0Dh)</p>
Response	<p>!AA00(data1)(data2)(cr) if the command is valid.</p> <p>?AA(cr) if an invalid operation was entered.</p> <p>! Delimiter indicating a valid command was received.</p> <p>? Delimiter indicating the command was invalid.</p> <p>AA represents the 2-character hexadecimal module address of an EDAM-5000 module.</p> <p>(data1) An 8-characters hexadecimal value representing the values of the digital input channels.</p> <p>(data2) An 8-characters hexadecimal value representing the values of the digital output channels.</p> <p>(cr) is the terminating character, carriage return (0Dh)</p>
Example	<p>Read the values of all DI/DO channels</p> <p>Command : \$016(cr)</p> <p>Response : !01000000F00000FD(cr)</p> <p>The 4~ 11 characters (000000F) indicate DI 0~3 channels are active, and DI 04~31 channels are inactive</p> <p>The 12~ 19 characters (000000FD) indicate DO 0,2,3,4,5,6,7 channels are active, and 1, 4, 8~31 channels are inactive</p>

10.4.53 \$AA5vvvv Enable/Disable A/D Channels

Description	Enables/disables multiplexing simultaneously for separate channels of a specified input module.
Syntax	<p>\$AA5vvvv(cr)</p> <p>\$ is a delimiter character.</p> <p>AA (range 00-FF) represents the 2-character hexadecimal address of module.</p> <p>5 is the Enable/disable Channels command.</p> <p>vvvv are four hexadecimal values. The values are interpreted by the module as four binary words (4-bit). The first word represents the status of channel 4~7, and the second word represents the status of channel 0~3...etc. Value 0 means the channel is disabled, value 1 means the channel is enabled.</p> <p>(cr) is the terminating character, carriage return (0Dh).</p>
Response	<p>!AA(cr) if the command is valid or ?AA (cr) if the command is invalid.</p> <p>There is no response if the module detects a syntax error or communication error.</p> <p>! Delimiter character indicates a valid command was received.</p> <p>? Delimiter character indicates the command was invalid.</p> <p>AA (range 00-FF) represents the 2-character hexadecimal address of module.</p> <p>(cr) is the terminating character, carriage return (0Dh).</p>
Example	<p>Command : \$0058100(cr)</p> <p>Response : !00(cr)</p> <p>Hexadecimal 8100 equals binary <u>1000 0001 0000 0000</u>, which enables channel 8, 15 and disables channels 0,1,2,3,4, 5, 6,7, and 9,10,11,12,13, and 14..</p>

10.4.54 \$AA8Ci Read the Single A/D Channel Range

Description	The command read individual channel type.
Syntax	<p>\$AA8Ci (cr)</p> <p>\$ is a delimiter character.</p> <p>AA (range 00-FF) represents the 2-character hexadecimal address of module.</p> <p>8C is the read channel type command.</p> <p>i channel number</p> <p>(cr) is the terminating character, carriage return (ODh).</p>
Response	<p>!AACiRrr(cr) if the command is valid or ?AA (cr) if the command is invalid.</p> <p>There is no response if the module detects a syntax error or communication error.</p> <p>! Is a delimiter character indicating a valid command was received.</p> <p>AA (range 00-3F) represents the 2-character hexadecimal address of module.</p> <p>i channel number(0~F)</p> <p>rr type of channel i</p> <p>(cr) is the terminating character, carriage return</p>
Examples	<p>Command : \$018C3(cr)</p> <p>Response : !01C3R08(cr)</p> <p>The type code of channel 3 is 08 (+/-10V).</p>

10.4.55 \$AA7CiRrr Set the Single Channel Range

Description	The command set channel type individually.
Syntax	<p>\$AA7CiRrr(cr)</p> <p>\$ is a delimiter character.</p> <p>AA (range 00-FF) represents the 2-character hexadecimal address of module.</p> <p>7C is the Set channel type command.</p> <p>i channel number</p> <p>rr channel type code</p> <p>(cr) is the terminating character, carriage return (ODh).</p>
Response	<p>!AA if the command is valid or ?AA (cr) if the command is invalid.</p> <p>There is no response if the module detects a syntax error or communication error.</p> <p>! Is a delimiter character indicating a valid command was received.</p> <p>AA (range 00-FF) represents the 2-character hexadecimal address of module.</p> <p>(cr) is the terminating character, carriage return</p>
Examples	<p>Command : 017C3R08(cr)</p> <p>Response : !01(cr)</p> <p>Set type code 08 (+/-10V) to channel 3.</p>

10.4.56 \$AAS1 Reload the Default configuration

Description	Reloads the Default configuration
Syntax	<p>\$AAS1(cr)</p> <p>\$ is a delimiter character.</p> <p>AA (range 00-FF) represents the 2-character hexadecimal address of module.</p> <p>Is the Reloads the Default configuration command.</p> <p>(cr) is the terminating character, carriage return (ODh).</p>
Response	<p>!AA(cr) if the command is valid or ?AA (cr) if the command is invalid.</p> <p>There is no response if the module detects a syntax error or communication error.</p> <p>! Delimiter character indicates a valid command was received.</p> <p>? Delimiter character indicates the command was invalid.</p> <p>AA (range 00-3F) represents the 2-character hexadecimal address of module.</p> <p>(cr) is the terminating character, carriage return (ODh).</p>
Example	<p>Command : \$01S1(cr)</p> <p>Response : !01(cr)</p> <p>Reloads the Default configuration</p>

10.4.57 @AA Read the Digital I/O Status

Description	read the status of its digital input and digital output channels
Syntax	AA(cr) @ is a delimiter character. AA (range 00-3F) represents the 2-character hexadecimal Modbus network address (Always 01) (cr) is the terminating character, carriage return (0Dh)
Response	>(DI data)(DO data)(cr) if the command is valid. ?AA(cr) if an invalid operation was entered. There is no response if the module detects a syntax error or communication error or if the address does not exist. > Delimiter indicating a valid command was received. ? Delimiter indicating the command was invalid. AA (range 00-3F) represents the 2-character hexadecimal Modbus network address of an EDAM-9000 module. (DI data) 4-character hexadecimal value representing the values of the digital input module. (DO data) 4-character hexadecimal value representing the values of the digital output module. (cr) is the terminating character, carriage return (0Dh)
Example	Command : @01(cr) Response : >0000102000210001(cr) 00001020=the status of digital input channels. DI channels 4, 15 are active, and other channels are inactive 00210001=the status of digital output channels. DO channels 0, 16, 18 are active, and other channels are inactive

10.4.58 @AAnn Set the Digital Output Channels

Description	Sets the Digital Output Channels Command : @AAnn(cr)
Syntax	@ Command leading code AA Module address ID (00-3F) nn Output value to channel 0~7 (cr) is the terminating character, carriage return (0Dh)
Response	!AA(cr) Valid command ?AA(cr) Invalid command (cr) is the terminating character, carriage return (0Dh)
Example	Command : @0523(cr) Response : !05(cr) ! Valid command 05 Module ID 23 Set 23(Hex) to Digital output channels (channel 0, 1, 5 are active, other channels are inactive)

10.4.59 @AAnnnn Set the Digital Output Channels

Description	Sets the value to Digital Output Channels 0~15 Command : @AAnnnn(cr)
Syntax	@ Command leading code AA Module address ID (00-3F) nnnn Output value to channel 0~15 (cr) is the terminating character, carriage return (0Dh)
Response	!AA(cr) Valid command ?AA(cr) Invalid command (cr) is the terminating character, carriage return (0Dh)
Example	Command : @050023(cr) Response : !05(cr) ! Valid command 05 Module ID 0023 Set 23(Hex) to Digital output channels (channel 0, 1, 5 are active, and channel 2,3,5,6,7,8,9,10,11,12,13,14,15 are inactive)

10.4.60 @AAnnnnnn Set The Digital Output Channels

Description	Sets the Digital Output Channels (0~23) Command : @AAnnnnnn(cr)
Syntax	@ Command leading code AA Module address ID (00-3F) nnnnnn Output value to channel 0~23 (cr) is the terminating character, carriage return (0Dh)
Response	!AA(cr) Valid command ?AA(cr) Invalid command (cr) is the terminating character, carriage return (0Dh)
Example	Command : @05010323(cr) Response : !05(cr) ! Valid command 05 Module ID 010323 Set 23(Hex)to Digital output channels (channel 0,1,5,8,9,16 are active, other channels are inactive)

10.4.61 #AA0Ann Set The Digital 1's Byte(DO0~DO7) Output

Description	Sets the value to Digital Output Channels 0~7 Command : #AA0Ann(cr)
Syntax	# Command leading code AA Module address ID (00-3F) 0A is the Sets the Digital Output lowest byte (DO0~DO7) command nn Output value to channel 0~7 (cr) is the terminating character, carriage return (0Dh)
Response	!AA(cr) Valid command ?AA(cr) Invalid command (cr) is the terminating character, carriage return (0Dh)
Example	Command : #050A23(cr) Response : !05(cr) ! Valid command 05 Module ID 23 Set 23(Hex) to Digital output channels (channel 0, 1, 5 are active, and channel 2, 3, 4, 6, 7 are inactive)

10.4.62 #AA0Bnn Set The Digital 2's Byte(DO8~DO15) Output

Description	Sets the value to Digital Output Channels 8~15 Command : #AA0Bnn(cr)
Syntax	# Command leading code AA Module address ID (00-3F) 0B is the Sets the Digital Output lowest byte(DO8~DO15) command nn Output value to channel 8~15 (cr) is the terminating character, carriage return (0Dh)
Response	!AA(cr) Valid command ?AA(cr) Invalid command (cr) is the terminating character, carriage return (0Dh)
Example	Command : #050B23(cr) Response : !05(cr) ! Valid command 05 Module ID 23 Set 23(Hex) to Digital output channels (channel 8,9,13 are active, and channel 10, 11,12,14,15 are inactive)

10.4.63 #AA0Cnn Set the Digital 3's byte(DO16~DO23) Output

Description	Sets the value to Digital Output Channels 16~23 Command : #AA0Cnn(cr)
Syntax	# Command leading code AA Module address ID (00-3F) 0C is the Sets the Digital Output lowest byte(DO16~DO23) command nn Output value to channel 16~23 (cr) is the terminating character, carriage return (0Dh)
Response	!AA(cr) Valid command ?AA(cr) Invalid command (cr) is the terminating character, carriage return (0Dh)
Example	Command : #050C23(cr) Response : !05(cr) ! Valid command 05 Module ID 23 Set 23(Hex) to Digital output channels (channel 16, 17, 21 are active, and channel 18, 19,21,22,23 are inactive)

10.4.64 #AAnn Read Digital Input Counter

Description	Read DI latch status.
Syntax	#AAnn(cr) # is a delimiter character. AA represents the 2-character hexadecimal Modbus address (Always 01) nn represents DI channel number . (cr) is the terminating character, carriage return (0Dh)
Response	!AAnnnnnnn(cr) if the command is valid. ?AA(cr) if an invalid operation was entered. ! Delimiter indicating a valid command was received. ? Delimiter indicating the command was invalid. AA represents the 2-character hexadecimal module address of an EDAM-5000 module. nnnnnnnn represents 4-bytes counter value (cr) is the terminating character, carriage return (0Dh)
Example	Read DI latch status Command : #0102(cr) Response : !0100000003 Latch status= 00000003, DI #2 counter value=3

10.4.65 \$AACn Clear Digital Input Counter

Description Clear Counter of all DI Channel

Syntax \$AACn(cr)
 \$ is a delimiter character.
 AA represents the 2-character hexadecimal module address
 C is Clear DI counter command.
 n is DI channel number
 (cr) is the terminating character, carriage return (0Dh).

Response !AA(cr) if the command is valid.
 ?AA(cr) if an invalid operation was entered.
 ! Delimiter indicating a valid command was received.
 ? Delimiter indicating the command was invalid.
 AA represents the 2-character hexadecimal address of an EDAM-5000 module.
 (cr) is the terminating character, carriage return (0Dh).

Example Clear DI #2 counters value
 Command : \$01C2(cr)
 Response : !01(cr)

10.4.66 \$AACnn Clear Digital Input Counter

Description Clear Counter of all DI Channel

Syntax \$AACnn(cr)
 \$ is a delimiter character.
 AA represents the 2-character hexadecimal module address
 C is Clear DI counter command.
 nn is DI channel number
 (cr) is the terminating character, carriage return (0Dh).

Response !AA(cr) if the command is valid.
 ?AA(cr) if an invalid operation was entered.
 ! Delimiter indicating a valid command was received.
 ? Delimiter indicating the command was invalid.
 AA represents the 2-character hexadecimal address of an EDAM-5000 module.
 (cr) is the terminating character, carriage return (0Dh).

Example Clear DI #2 counters value
 Command : \$01C02(cr)
 Response : !01(cr)

10.4.67 \$AALS Read The Latched DI Status

Description Read DI latch status.

Syntax \$AALS (cr)
 \$ is a delimiter character.
 AA represents the 2-character hexadecimal Modbus address (Always 01)
 LS represents read DI latch status command.
 (cr) is the terminating character, carriage return (0Dh)

Response !AAnnnnnnn(cr) if the command is valid.
 ?AA(cr) if an invalid operation was entered.
 ! Delimiter indicating a valid command was received.
 ? Delimiter indicating the command was invalid.
 AA represents the 2-character hexadecimal module address of an EDAM-5000 module.
 (cr) is the terminating character, carriage return (0Dh)

Example Read DI latch status
 Command : \$01LS (cr)
 Response : !0100000003
 Latch status= 00000003, DI #0 latched, DI #1 latched, and DI #2 ~ DI #11 no latched

10.4.68 \$AAC Clear the latched DI status

Description	Clear all digital input counter of specified DI channel.
Syntax	\$AAC(cr) \$ is a delimiter character. AA represents the 2-character hexadecimal module address CL is clear latch command. (cr) is the terminating character, carriage return (0Dh).
Response	!AA(cr) if the command is valid. ?AA(cr) if an invalid operation was entered. ! Delimiter indicating a valid command was received. ? Delimiter indicating the command was invalid. AA represents the 2-character hexadecimal address of an EDAM-5000 module. (cr) is the terminating character, carriage return (0Dh).
Example	Clear all latch status Command : \$01C(cr) Response : !01(cr)

10.4.69 \$AA9nn Read Single Do Pulse High/Low Width

Description	Read Do Pulse High/Low Width of specified DO channel
Command	\$AA9nn(cr)
Syntax	\$ Command leading code AA Module address ID (00-3F) 9 is the Read Do Pulse High/Low Width command nn Digital Output channel number (0~17) (cr) is the terminating character, carriage return (0Dh)
Response	!AAhhhhvvvv(cr) Valid command hhhh=high pulse width in 0.5msec, vvvv=low pulse width in 0.5msec ?AA(cr) Invalid command (cr) is the terminating character, carriage return (0Dh)
Example	Command : \$05902(cr) Response : !0502000100(cr) ! Valid command 05 Module ID 0200 high pulse width=0200(hex) =512(dec)*0.5msec=256 msec 0100 low pulse width=0100(hex) =256(dec)*05msec=128 msec

10.4.70 \$AA9nnhhhhllll Set Single Do Pulse High/Low Width

Description	set Do Pulse High/Low Width of specified DO channel
Command	\$AA9nnhhhhvvvv(cr)
Syntax	\$ Command leading code AA Module address ID (00-3F) 9 is the Read Do Pulse High/Low Width command nn Digital Output channel number (0~17) hhhh high pulse width in 0.5msec vvvv low pulse width in 0.5msec (cr) is the terminating character, carriage return (0Dh)
Response	!AAcr) Valid command ?AA(cr) Invalid command (cr) is the terminating character, carriage return (0Dh)
Example	Command : \$05902000100(cr) Response : !05(cr) ! Valid command 05 Module ID 0200 high pulse width=0200(hex)=512(dec)*0.5msec=256 msec 0100 low pulse width=0100(hex)=256(dec)*05msec=128 msec

10.4.71 \$AAAnn Read Single Do High/Low Delay Width

Description	Read Do High/Low output Delay time of specified DO channel
Command	\$AAAnn(cr)
Syntax	\$ Command leading code AA Module address ID (00-3F) A is the Read Do High/Low Delay time command nn Digital Output channel number (0~17) (cr) is the terminating character, carriage return (0Dh)
Response	!AAhhhvvv(cr) Valid command hhh high delay time in 0.5msec vvv low delay time in 0.5msec ?AA(cr) Invalid command (cr) is the terminating character, carriage return (0Dh)
Example	Command : \$05A02(cr) Response : !0502000100(cr) ! Valid command 05 Module ID 0200 high output delay time=0200(hex)=512(dec)*0.5msec=256 msec 0100 low low output delay time=0100(hex)=256(dec)*05msec=128 msec

10.4.72 \$AAAnnhhhlll Set Single Do High/Low Delay Width

Description	set Do High/Low output Delay time of specified DO channel
Command	\$AAAnnhhhvvv(cr)
Syntax	\$ Command leading code AA Module address ID (00-3F) A is the Read Do Pulse High/Low Width command nn Digital Output channel number (0~17) hhh high output delay time in 0.5msec vvv low output delay time in 0.5msec (cr) is the terminating character, carriage return (0Dh)
Response	!AAcr) Valid command ?AA(cr) Invalid command (cr) is the terminating character, carriage return (0Dh)
Example	Command : \$05A02000100(cr) Response : !05(cr) ! Valid command 05 Module ID 0200 high output delay time=0200(hex)=512(dec)*0.5msec=256 msec 0100 low output delay time=0100(hex)=256(dec)*05msec=128 msec

10.4.73 \$AABnn Read Single Do Pulse Counts

Description	Read Pulse Counts of single DO channel
Syntax	\$AABnn(cr) \$ is a delimiter character. AA represents the 2-character hexadecimal module address B is read pulse counts command. nn represents DO channel number (cr) is the terminating character, carriage return (0Dh).
Response	!AAcccc(cr) if the command is valid. ?AA(cr) if an invalid operation was entered. ! Delimiter indicating a valid command was received. ? Delimiter indicating the command was invalid. AA represents the 2-character hexadecimal address of an EDAM-5000 module. cccc represents DO pulse counts (cr) is the terminating character, carriage return (0Dh).
Example	Read pulse counts of DO channel 03 Command : \$01B03(cr) Response : !010020(cr) The pulse counts of DO channel 03 is 0020(hex) =32(dec)

10.4.74 #AA2nncccc Write Single Do Pulse Counts

Description	Set Pulse Counts of Single DO channel
Syntax	#AA2nncccc(cr) # is a delimiter character. AA represents the 2-character hexadecimal module address 2 is set DO pulse counts command. nn is DO channel number cccc represents DO pulse output counts (cr) is the terminating character, carriage return (0Dh).
Response	!AA(cr) if the command is valid. ?AA(cr) if an invalid operation was entered. ! Delimiter indicating a valid command was received. ? Delimiter indicating the command was invalid. AA represents the 2-character hexadecimal address of an EDAM-5000 module. (cr) is the terminating character, carriage return (0Dh).
Example	Set DO pulse output counts=32 of DO channels 5 Command : #012050020(cr) Response : !01(cr)

10.4.75 #AA3nns Start/Stop DO Pulse Counts

Description	Start/stop DO pulse output of single DO channel
Syntax	#AA3nns(cr) # is a delimiter character. AA represents the 2-character hexadecimal module address 3 is Start/stop DO pulse command. nn is DO channel number s s=0 represents stop pulse output, s=1 represents start pulse output (cr) is the terminating character, carriage return (0Dh).
Response	!AA(cr) if the command is valid. ?AA(cr) if an invalid operation was entered. ! Delimiter indicating a valid command was received. ? Delimiter indicating the command was invalid. AA represents the 2-character hexadecimal address of an EDAM-5000 module. (cr) is the terminating character, carriage return (0Dh).
Example	Start pulse output of DO channels 5 Command : #013051(cr) Response : !01(cr)

10.4.76 #AA3nnnnnnnn Start/Stop multiple DO Pulse Counts

Description	Start/stop DO pulse output of multiple DO channel
Syntax	#AA3nnnnnnnn(cr) # is a delimiter character. AA represents the 2-character hexadecimal module address 3 is Start/stop DO pulse command. nnnnnnnnnn is DO channel number start/stop bit bit m=0 stop channel m pulse output, m=1 start channel m pulse output (cr) is the terminating character, carriage return (0Dh).
Response	!AA(cr) if the command is valid. ?AA(cr) if an invalid operation was entered. ! Delimiter indicating a valid command was received. ? Delimiter indicating the command was invalid. AA represents the 2-character hexadecimal address of an EDAM-5000 module. (cr) is the terminating character, carriage return (0Dh).
Example	Start pulse output of DO channels 0,1,2,3,5,15 (0000802F) Command : #0130000802F(cr) Response : !01(cr)

10.4.77 ~AA4v Read The Power On/Safe Value

Description	Read power-on/safe value
Syntax	~AA4v(cr) ~ Command leading code AA Module address ID (00 to FF) 4 Command to set DO power-on/safe value v v="P" set power-on value, v="S" set safe value (cr) Carriage return
Response	!AA(cr) if the valid command ? AA(cr) Invalid command ! Delimiter for valid command ? Delimiter for invalid command (cr) Carriage return
Example	Read power-on/safe value (ID=05) Command : ~054P(cr) Response : !0500000014(cr) //power-on value=00000014 (DO channel 2, 4 on)

10.4.78 ~AA5v Set Current Do Value As Power On/Safe Value

Description	Set current DO value as power-on/safe value
Syntax	~AA5v(cr) ~ Command leading code AA Module address ID (00 to FF) 5 Command to set DO power-on/safe value v v="P" set power-on value, v="S" set safe value (cr) Carriage return
Response	!AA(cr) if the valid command ? AA(cr) Invalid command ! Delimiter for valid command ? Delimiter for invalid command (cr) Carriage return
Example	Set current DO value as power-on/safe value (ID=04) Command : ~045P(cr) Response : !04(cr)

10.4.79 ~AA5vnnnnnn Set Specified Value As Power On/Safe Value

Description	Set DO power-on/safe value
Syntax	~AA5vnnnnnn(cr) ~ Command leading code AA Module address ID (00 to FF) 5 Command to set DO power-on/safe value v v="P" set power-on value, v="S" set safe value nnnnnn represents DO power-on/safe value (cr) Carriage return
Response	!AA(cr) if the valid command ? AA(cr) Invalid command ! Delimiter for valid command ? Delimiter for invalid command (cr) Carriage return
Example	Set DO power-on value to 0xFF00FF(ID=04) Command : ~045PFF00FE(cr) Response : !04(cr)
Example	Set DO safe value to 0xFF00FF(ID=04) Command : ~045SFF00FE(cr) Response : !04(cr)

10.4.80 ~AAD Read DI/O Active State

Description	Read input/output active status.
Syntax	~AAD(cr) ~ Command leading code AA Module address ID (00 to FF) D Command for reading digital input active status (cr) Carriage return
Response	!AAm(cr) if the valid command ? AA(cr) if the invalid command ! Delimiter for valid command ? Delimiter for invalid command m Input active status, m=0 input low voltage/open active, m=1 Input high voltage active (See *) n Output active status, n=1 output short/close active, n=0 open active (See **) (cr) Carriage return
Example	Read output active status of EDAM5060 (ID=05) Command : ~05D(cr) Response : !0501(cr)
Note	01 All input channels are low active and all output channels are short/close active (*) : m is only available for the module which has digital input channels (**) : n is only available for the module which has digital output channels

10.4.81 ~AADvn Set DI/O Active State

Description	Set input/output active status.
Command	~AADvn[CHK](cr)
Syntax	~ Command leading code AA Module address ID (00 to FF) D Command for setting digital input active status v Input active status, v=0 input low voltage/open active, v=1 Input high voltage active (See *) n Output active status, n=1 output short/close active, n=0 open active (See **) (cr) is the terminating character, carriage return (0Dh)
Response	!AA (cr) Valid command ?AA(cr) Invalid command (cr) is the terminating character, carriage return (0Dh)
Example	Command : ~05D01(cr) Response : !05(cr) 05 Module ID 0 Set all inputput channels to high volt/open active 1 Set all output channels to high/open output active
Note:	(*) : v is only available for the module which has digital input channels (**) : n is only available for the module which has digital output channels

10.4.82 ~AASDBv Set DI debounce mode

Description	The command set digital input channel debounce mode (pre-read or post-read mode)
Syntax	~AASDBv(cr) ~ Is a delimiter character. AA (range 00-FF) represents the 2-character hexadecimal address of module. SDB is the Set DI debounce mode command v v=0 pre-read mode ,v=1 post-read mode (cr) Is the terminating character, carriage return (0Dh).
Response	!AA(cr) If the command is valid or ?AA (cr) if the command is invalid There is no response if the module detects a syntax error or communication error. ! Is a delimiter character. AA (range 00-3F) represents the 2-character hexadecimal address of module. (cr) Is the terminating character, carriage return (0Dh)
Example	Command : ~01SDB1(cr) Response : !01(cr) The command Set DI debounce mode to post read mode

10.4.83 ~AARDB Readet DI debounce mode

Description	The command readt digital input channel debounce mode (pre-read or post-read mode)
Syntax	~AARDB(cr) ~ Is a delimiter character. AA (range 00-FF) represents the 2-character hexadecimal address of module. RDB is the Set DI debounce mode command (cr) Is the terminating character, carriage return (0Dh).
Response	!AAv(cr) If the command is valid or ?AA (cr) if the command is invalid There is no response if the module detects a syntax error or communication error. ! Is a delimiter character. AA (range 00-3F) represents the 2-character hexadecimal address of module. v v=0 pre-read mode ,v=1 post-read mode (cr) Is the terminating character, carriage return (0Dh)
Example	Command : ~01RDB(cr) Response : !011(cr) The command DI debounce mode is post read mode

Chapter 11 E5KDAQ.DLL API

11.1 Common Functions

Function Name	Description	Sec.
E5K_SearchModules	Search all EDAM5000 modules	0
E5K_OpenModuleUSB	Open module with ID address from USB interface	11.5
E5K_OpenModuleIP	Open module with the module IP address from Ethernet	11.6
E5K_OpenModuleIPEx	Open module with the module IP address from Ethernet and specified HOST IP address (For multiple NIC cards)	11.7
E5K_OpenModuleCOM	Open module with ID address from COM port	11.8
E5K_CloseModules	Close all modules	11.9
E5K_GetDLLVersion	Get E5KDAQ.DLL version	11.10
E5K_VerifyPassWord	Verifies Pass word (Ethernet only)	11.11
E5K_ChangePassWord	Change password (Ethernet connection only)	11.12
E5K_GetLastErrorCode	Get last DLL error code	11.13
E5K_SetRXTimeOutOption	Set receive/send Timeout	11.14
E5K_StartAlarmEventIP	Start alarm event from the default Host IP (Ethernet only)	11.15
E5K_StartAlarmEventIPEx	Start Taregt alarm event from the specified Host IP (For multiple NIC cards)	11.16
E5K_StopAlarmEventIP	Stop alarm event from IP (Ethernet only)	11.17
E5K_StartAlarmEventUSB	Start alarm event from USB (USB only)	11.18
E5K_StopAlarmEventUSB	Stop alarm event from USB (USB only)	11.19
E5K_ReadAlarmEventData	Read alarm event data	11.20
E5K_StartStreamEvent	Start stream event from from the default Host IP (Ethernet only)	11.21
E5K_StartStreamEventEx	Start Taregt stream event from the specified Host IP (For multiple NIC cards)	11.22
E5K_StopStreamEvent	Stop stream event from IP (Ethernet only)	11.23
E5K_ReadStreamEventData	Read stream data from IP (Ethernet only)	11.24
E5K_ReadModuleConfig	Read module configuration	11.25
E5K_SetModuleConfig	Set module configuration	11.26
E5K_WriteModbusDiscrete	Write Modbus discrete(coil/input) data to the specified module	11.27
E5K_WriteModbusRegister	Write Modbus register(holding/input) data to the specified module	11.28
E5K_ReadModbusRegister	Read Modbus (holding/input)register data from the specified module	11.29
E5K_ReadModbusDiscrete	Read Modbus (coil/input)discrete data from the specified module	11.30
E5K_SendASCRequestAndWaitResponse	Send ASCII command to and wait response from the specified module	11.31
E5K_RecvASCII	Receive ASCII data from the specified module	11.32
E5K_SendASCII	Send ASCII command to specified module	11.33
E5K_SendHEXRequestAndWaitResponse	Send binary data to and wait response from the specified module	11.34
E5K_SendHEX	Send HEX command to specified module	11.35
E5K_RecvHEX	Receive Hex data from the specified module	11.36
E5K_CalculateCRC16	Calculate CRC16	11.37
E5K_SetLEDControl	Set LED control mode	11.38
E5K_WriteDataToLED	Write data to LED board	11.39
E5K_FlashLED	Force on-board LED to flash	11.40
E5K_IsValidIPAddress	Check IP address is valid or not	11.41
E5K_IsIPInLocalSubnet	Check Target IP in the default Host IP subnet	11.42
E5K_IsIPInLocalSubnetEx	Check Target IP in the specified Host IP subnet (For multiple NIC cards)	11.43
E5K_GetLocalIP	Get Host IP address	11.44
E5K_TCPConnect	Build a TCP connection from default Host IP address	11.45
E5K_TCPConnectEx	Build a TCP connection from the specified Host IP (For multiple NIC cards)	11.46
E5K_TCPSendData	Send data to TCP connection	11.47
E5K_TCPRecvData	Receive data from TCP connection	11.48
E5K_TCPPing	Ping the specified IP address	11.49
E5K_TCPDisconnect	Disconnect specified TCP connection	11.50
E5K_TCPAllDisconnect	Disconnect all TCP connections	11.51
E5K_UDPConnect	Build an UDP connection from default Host IP address	11.52
E5K_UDPConnectEx	Build an UDCP connection from the specified Host IP (For multiple NIC cards)	11.53
E5K_UDPSendData	Send binary data to UDP connection	11.54
E5K_UDPRecvData	Receive binary data from UDP connection	11.55
E5K_UDPSendASCStr	Send an ASCII string to UDP connection	11.56
E5K_UDPRecvASCStr	Receive an ASCII string from UDP connection	11.57
E5K_UDPDisconnect	Disconnect specified UDP connection	11.58
E5K_UDPAllDisconnect	Disconnect all UDP connections	11.59

11.2 Analog Functions

Function name	Description	Sec.
E5K_ReadAIChannelType	Read type of the specified AI channel	11.51
E5K_SetAIChannelType	Set type of the specified AI channel	11.61
E5K_SetSingleChannelColdJunctionOffset	Set CJC offset of the specified AI channel	0
E5K_ReadSingleChannelColdJunctionOffset	Read CJC offset of a specified AI channel	11.63
E5K_ReadMultiChannelColdJunctionOffset	Read CJC offset of the multiple AI channels	11.64
E5K_SetMultiChannelColdJunctionOffset	Set CJC offset of multiple AI channels	11.65
E5K_ReadColdJunctionTemperature	Read cold junction temperature	11.66
E5K_ReadColdJunctionStatus	Read cold junction enable/disable status	11.67
E5K_SetColdJunction	Enable/disable CJC	11.68
E5K_ReadAIChannelConfig	Read configuration of the specified AI channel	11.69
E5K_SetAIChannelConfig	Set configuration of the specified AI channel	11.70
E5K_ReadAIBurnOutStatus	Read burnout status of analog channels	11.71
E5K_ReadAIAlarmStatus	Read AI alarm event status	11.72
E5K_SetAIBurnOut	Enable/disable burnout detection	11.73
E5K_ReadAIBurnOut	Read AI burnout detection enable/disable status	11.74
E5K_SetAIModuleFilter	Set AI filter frequency	11.75
E5K_ReadAIModuleFilter	Read AI filter frequency	11.76
E5K_SetAIChannelEnable	Enable/disable AI channel	11.77
E5K_ReadAIChannelEnable	Read enable/disable status of AI channels	11.78
E5K_ReadAINormalMultiChannel	Read AI normal value of multiple AI channels	11.79
E5K_ReadAIMaximunMultiChannel	Read AI maximum value of multiple AI channels	11.80
E5K_ReadAIMinimunMultiChannel	Read AI minimum value of multiple AI channels	11.81
E5K_ResetAIMaximun	Reset Maximum value of the specified AI channels	11.82
E5K_ResetAIMinimun	Reset Minimum value of the specified AI channels	11.83
E5K_ResetAIHighAlarm	Reset high alarm flag of the specified AI channels	11.84
E5K_ResetAILowAlarm	Reset low alarm flag of the specified AI channels	11.85
E5K_ReadAIChannelAverage	Read in average status of AI channels	11.86
E5K_SetAIChannelAverage	Enable AI channels in average	11.87

11.3 DIO Functions

Function Name	Description	Sec.
E5K_SetDIChannelConfig	Set configuration of the specified DI channel	11.88
E5K_ReadDIChannelConfig	Read configuration of the specified DI channel	11.89
E5K_ReadDIStatus	Read DI status	11.90
E5K_ReadDILatch	Read DI latch status	11.91
E5K_ClearAllDILatch	Clear all DI latch status	11.92
E5K_ClearSingleDICounter	Clear counter value of the specified DI channel	11.93
E5K_ReadMultiDICounter	Read multiple DI counter value	11.94
E5K_WriteDO	Write DO channels	11.95
E5K_ReadDOStatus	Read DO status	11.96
E5K_SetDOSingleChannel	Set/reset single DO channel	11.97
E5K_SetDOPulseWidth	Set DO pulse high/low width	11.98
E5K_ReadDOPulseWidth	Read DO pulse high/low width	11.99
E5K_StartDOPulse	Start DO pulse output	11.100
E5K_StopDOPulse	Stop DO pulse output	11.102
E5K_ReadDOPulseCount	Read back DO pulse count value	11.103
E5K_SetDOPowerOnValue	Set DO power on value	11.104
E5K_ReadDOPowerOnValue	Read DO power on value	11.105
E5K_ReadDIOActiveLevel	Read DI/DO active flag setting	0
E5K_SetDIOActiveLevel	Set DI/O channel active flag	11.107

11.4 E5K_SearchModules

Description	Search all connected EDAM-5000 modules
Syntax	<p>Visual Basic/VB.Net: (see E5KDAQ.bas/E5KDAQ.vb) Declare/public Function E5K_SearchModules Lib "E5KDAQ.dll" (Pd as E5K_DEVICE_ID_INFO, interface_type as integer) as integer VC++/BC++Builder: (see E5KDAQ.h) Unsigned short E5K_SearchModules (E5K_DEVICE_ID_INFO *pd,unsigned int interface_type);</p>
Parameters	<p>Pd points to a structure E5K_DEVICE_ID_INFO Interface_type indicate what connection be used for searching (see E5KDAQ.h)</p>
Return Code	Return how many modules be found, It no module existed, if return with 0

11.5 E5K_OpenModuleUSB

Description	Open module by its ID address from USB interface
Syntax	<p>Visual Basic/VB.Net: (see E5KDAQ.bas/E5KDAQ.vb) Declare/public Function E5K_OpenModuleUSB Lib "E5KDAQ.dll" (ByVal id As Integer) As Integer VC++/BC++Builder: (see E5KDAQ.h) Unsigned short E5K_OpenModuleUSB (unsigned short id);</p>
Parameters	Id module ID address
Return Code	Return the same ID number as parameter id, if open success Return -1 open error

11.6 E5K_OpenModuleIP

Description	Open module by IP address feom default Host IP (for Ethernet connection only)
Syntax	<p>Visual Basic/VB.Net: (see E5KDAQ.bas/E5KDAQ.vb) Declare/public Function E5K_OpenModuleIP Lib "E5KDAQ.dll" _ (ByVal IP As String,Byval Byval ConnecttimeOut as long, Byval RxTotalTimeOut as long, Byval RxTimeoutInterval as long) As Integer VC++/BC++: (see E5KDAQ.h) Unsigned short E5K_OpenModuleIP (Char IP[], unsigned long ConnectTimeOut, unsigned long RxTotalTimeOut, unsigned long RxTimeoutInterval);</p>
Parameters	<p>IP points to an IP address array (such as "192.168.0.12") ConnectTimeOut Connection timeout interval (msec) RxTotalTimeOut Receive frame timeout interval (msec) RxTimeOutInterval receive character timeout interval (msec)</p>
Return Code	Return the ID address of module, if open success

11.7 E5K_OpenModuleIPEX

Description	Open module by IP address from specified Host IP (for Ethernet connection only)	
Syntax	<p>Visual Basic/VB.Net: (see E5KDAQ.bas/E5KDAQ.vb) Declare/public Function E5K_OpenModuleIPEX Lib "E5KDAQ.dll" _ (ByVal IP As String,Byval Byval ConnecttimeOut as long, Byval RxTotalTimeOut as long, Byval RxTimeoutInterval as long, Byval HostIP as string) As Integer</p> <p>VC++/BC++: (see E5KDAQ.h) Unsigned short E5K_OpenModuleIPEX (Char IP[], unsigned long ConnectTimeOut, unsigned long RxTotalTimeOut, unsigned long RxTimeoutInterval, char HostIP[]);</p>	
Parameters	IP	points to target IP address array (such as "192.168.0.12")
	ConnectTimeOut	Connection timeout interval (msec)
	RxTotalTimeOut	Receive frame timeout interval (msec)
	RxTimeOutInterval	receive character timeout interval (msec)
	HostIP	points to specified Host IP (for multiple NIC cards)
Return Code	If open success, return the ID address of module, otherwise -1	

11.8 E5K_OpenModuleCOM

Description	Open module by its ID address from COM port	
Syntax	<p>Visual Basic/VB.Net: (see E5KDAQ.bas/E5KDAQ.vb) Declare/public Function E5K_OpenModuleCOM Lib "E5KDAQ.dll" _ (Byval devid As Integer, Byval comport As Integer, ByVal RxTotalTimeOut As Long, ByVal RxTimeoutInterval As Long, ByVal BaudRate As Long, ByVal ChksumCRC As Byte) As Integer</p> <p>VC++/BC++Builder: (see E5KDAQ.h) int E5K_OpenModuleCOM(unsigned int devid, unsigned int comport, unsigned long RxTotalTimeOut, unsigned long RxTimeoutInterval, unsigned long Baudrate, unsigned char ChksumCRC);</p>	
Parameters	devid	module ID address
	comport	COM port number
	RxTotalTimeOut	Receive time out between characters(msec)
	RxTimeoutInterval	Receive total timeout (msec)
	Baudrate	Baud rate
	ChksumCRC	Enable/disable Check sum/ CRC (1=Enabled,0=disable)
Return Code	If open success, return the ID address of module, otherwise -1	

11.9 E5K_CloseModules

Description	Close all modules
Syntax	<p>Visual Basic/VB.Net: (see E5KDAQ.bas/E5KDAQ.vb) Declare/public Function E5K_CloseModules Lib "E5KDAQ.dll" () As Integer</p> <p>VC++: (see E5KDAQ.h) Unsigned short E5K_CloseModules (void);</p>
Parameters	none no parameters
Return Code	refers to the Error code .

11.10 E5K_GetDLLVersion

Description	Get version of E5KDAQ.DLL
Syntax	<p>Visual Basic/VB.Net: (see E5KDAQ.bas/E5KDAQ.vb) Declare/public Function E5K_GetDLLVersion Lib "E5KDAQ.dll" _ (ByRef Major As Integer, ByRef Minor As Integer) As Integer</p> <p>VC++: (see E5KDAQ.h) Unsigned short E5K_GetDLLVersion (unsigned int *Major, unsigned int *Minor);</p>
Parameters	<p>Major points' version major buffer Minor point's version minor buffer</p>
Return Code	refers to the Error code .

11.11 E5K_VerifyPassWord

Description	Verify password of the Ethernet connected module. The function should be called after calling E5K_OpenModuleIP () function (for Ethernet Connection only)
Syntax	<p>Visual Basic/VB.Net: (see E5KDAQ.bas/E5KDAQ.vb) Declare/public Function E5K_VerifyPassWord Lib "E5KDAQ.dll" _ (ByVal id As Integer, ByVal Password as String, ByVal length As Integer) As Integer</p> <p>VC++: (see E5KDAQ.h) Unsigned short E5K_VerifyPassWord (int id , UNSIGNED CHAR Password[], unsigned int length);</p>
Parameters	<p>Id module ID address Password points to password string buffer Length password length</p>
Return Code	Refer to the Error code .

11.12 E5K_ChangePassWord

Description Change password of the Ethernet connected module. The function is available after calling E5K_VerifyPassWord function (for Ethernet Connection only)

Syntax Visual Basic/VB.Net: (see [E5KDAQ.bas/E5KDAQ.vb](#))
 Declare/public Function E5K_ChangePassWord Lib "E5KDAQ.dll" _
 (ByVal id As Integer, _
 ByVal OldPassword as String, _
 ByVal Oldlength as Integer, _
 ByVal NewPassword as String, _
 ByVal Newlength as Integer) As Integer

VC++: (see [E5KDAQ.h](#))
 Unsigned short E5K_ChangePassWord (
 int id,
 unsigned char oldPassWord[],
 unsigned int oldlength,
 unsigned char newPassWord[],
 unsigned int newlength);

Parameters	id	module ID address
	oldPassWord[]	points to password string buffer
	oldlength	old password length
	newPassWord[]	points to new password,
	newlength	new password length

Return Code

11.13 E5K_GetLastErrorCode

Description Get E5KDAQ.dll last error code

Syntax Visual Basic/VB.Net: (see [E5KDAQ.bas/E5KDAQ.vb](#))
 Declare/public Function E5K_GetLastErrorCode Lib "E5KDAQ.dll" () As Integer

VC++: (see [E5KDAQ.h](#))
 Unsigned short E5K_GetLastErrorCode (void);

Parameters	none	no parameters
-------------------	------	---------------

Return Code

11.14 E5K_SetRXTimeOutOption

- Description** Set receive total timeout and interval timeout of COM port and TCP/IP
- Syntax** Visual Basic/VB.Net: (see [E5KDAQ.bas/E5KDAQ.vb](#))
 Declare/public Function E5K_SetRXTimeOutOption Lib "E5KDAQ.dll" _
 (ByVal RxTotalTimeout as Long, ByVal RxChrTimeOutInterval as Long) As Integer
- VC++: (see [E5KDAQ.h](#))
 Unsigned short E5K_SetRXTimeOutOption (long RxTotalTimeout, long RxChrTimeOutInterval);
- Parameters** RxTotalTimeout receive total timeout (msec)
 Length receive character interval timeout (msec)
- Return Code** Refer to the [Error code](#).

11.15 E5K_StartAlarmEventIP

- Description** Start target alarm event from the default Host IP
- Syntax** Visual Basic/VB.Net: (see [E5KDAQ.bas/E5KDAQ.vb](#))
 Declare/public Function E5K_StartAlarmEventIP Lib "E5KDAQ.dll"
 (ByVal IPAddress As string) As long
- VC++: (see [E5KDAQ.h](#))
 long E5K_StartAlarmEventIP (char * IPAddress);
- Parameters** IPAddress Alarm event source IP address
- Return Code** Event handle or -1 for error (Refer to the [Error code](#).)

11.16 E5K_StartAlarmEventIPEx

- Description** Start target alarm event from the specified Host IP (for multiple NIC cards)
- Syntax** Visual Basic/VB.Net: (see [E5KDAQ.bas/E5KDAQ.vb](#))
 Declare/public Function E5K_StartAlarmEventIPEx Lib "E5KDAQ.dll"
 (ByVal IPAddress As string, ByVal HostIP As string) As long
- VC++: (see [E5KDAQ.h](#))
 long E5K_StartAlarmEventIPEx (char * IPAddress, char * HostIP);
- Parameters** IPAddress Alarm event source IP address
 HostIP Specifies Host IP
- Return Code** Event handle or -1 for error (Refer to the [Error code](#).)

11.17 E5K_StopAlarmEventIP

Description	Stop alarm event from IP
Syntax	Visual Basic/VB.Net: (see E5KDAQ.bas/E5KDAQ.vb) Declare/public Function E5K_StopAlarmEventIP Lib "E5KDAQ.dll" (ByVal IPAddress As string) As Integer VC++: (see E5KDAQ.h) Int E5K_StopAlarmEventIP (char * IPAddress);
Parameters	IPAddress Alarm event source IP address
Return Code	Refer to the Error code .

11.18 E5K_StartAlarmEventUSB

Description	Start alarm event from USB connection
Syntax	Visual Basic/VB.Net: (see E5KDAQ.bas/E5KDAQ.vb) Declare/public Function E5K_StartAlarmEventUSB Lib "E5KDAQ.dll" (ByVal Id As integer) As long VC++: (see E5KDAQ.h) long E5K_StartAlarmEventUSB (int Id);
Parameters	Id Alarm event source Id
Return Code	Refer to the Error code .

11.19 E5K_StopAlarmEventUSB

Description	Stop alarm event from USB connection
Syntax	Visual Basic/VB.Net: (see E5KDAQ.bas/E5KDAQ.vb) Declare/public Function E5K_StopAlarmEventUSB Lib "E5KDAQ.dll" (ByVal Id As integer) As Integer VC++: (see E5KDAQ.h) Int E5K_StopAlarmEventUSB (int Id);
Parameters	Id Alarm event source Id
Return Code	Refer to the Error code .

11.20 E5K_ReadAlarmEventData

Description	Read alarm event information from device
Syntax	Visual Basic/VB.Net: (see E5KDAQ.bas/E5KDAQ.vb) Declare/public Function E5K_ReadAlarmEventData Lib "E5KDAQ.dll" (Intinfo as ALARM_EVENT_INF) As Integer VC++: (see E5KDAQ.h) Int E5K_ReadAlarmEventData (struct ALARM_EVENT_INF *Intinfo);
Parameters	Intinfo Points to an Alarm event structure (ALARM_EVENT_INF)
Return Code	Refer to the Error code .

11.21 E5K_StartStreamEvent

Description	Start target stream event from the default Host IP
Syntax	Visual Basic/VB.Net: (see E5KDAQ.bas/E5KDAQ.vb) Declare/public Function E5K_StartStreamEvent Lib "E5KDAQ.dll" (ByVal IPAddress As string) As long VC++: (see E5KDAQ.h) long E5K_StartStreamEventIP (char * IPAddress);
Parameters	IPAddress Stream data event source IP address
Return Code	Event handle or -1 for error (Refer to the Error code .)

11.22 E5K_StartStreamEventEx

Description	Start target stream event from the specified Host IP (for multiple NIC cards)
Syntax	Visual Basic/VB.Net: (see E5KDAQ.bas/E5KDAQ.vb) Declare/public Function E5K_StartStreamEventEx Lib "E5KDAQ.dll" (ByVal IPAddress As string, ByVal HostIP) As long VC++: (see E5KDAQ.h) long E5K_StartStreamEventIPEX (char * IPAddress, char * HostIP);
Parameters	IPAddress Stream data event source IP address HostIP Specifies Host IP (for multiple NIC cards)
Return Code	Event handle or -1 for error (Refer to the Error code .)

11.23 E5K_StopStreamEvent

Description	Stop to receive stream data from IP
Syntax	Visual Basic/VB.Net: (see E5KDAQ.bas/E5KDAQ.vb) Declare/public Function E5K_StopStreamEvent Lib "E5KDAQ.dll" (ByVal IPAddress As string) As Integer VC++: (see E5KDAQ.h) Int E5K_StoptStreamEventIP (char * IPAddress);
Parameters	IPAddress Stream data event source IP address
Return Code	refers to the Error code .

11.24 E5K_ReadStreamEventData

Description	Read stream data from IP
Syntax	Visual Basic/VB.Net: (see E5KDAQ.bas/E5KDAQ.vb) Declare/public Function E5K_ReadStreamEventData Lib "E5KDAQ.dll" (StreamIntInfo As STREAM_EVENT_INFO) As Integer VC++: (see E5KDAQ.h) Int E5K_ReadStreamEventDa (STREAM_EVENT_INFO StreamIntInfo[]);
Parameters	StreamIntInfo Points to a stream data buffer (structure STREAM_EVENT_INFO) (see E5KDAQ.H)
Return Code	Refer to the Error code .

11.25 E5K_ReadModuleConfig

Description	Read module configuration
Syntax	Visual Basic/VB.Net: (see E5KDAQ.bas/E5KDAQ.vb) Declare/public Function E5K_ReadModuleConfig Lib "E5KDAQ.dll" _ (ByVal id As Integer, mp as MODULE_CONFIG) As integer VC++: (see E5KDAQ.h) Unsigned short E5K_ReadModuleConfig (unsigned int id, MODULE_CONFIG *mp);
Parameters	id module ID address mp points to a structure MODULE_CONFIG (see E5KDAQ.H)
Return Code	Refer to the Error code .

11.26 E5K_SetModuleConfig

Description	Set module configuration
Syntax	<p>Visual Basic/VB.Net: (see E5KDAQ.bas/E5KDAQ.vb) Declare/public Function E5K_SetModuleConfig Lib "E5KDAQ.dll" _ (ByVal id As Integer , mp as MODULE_CONFIG) As integer</p> <p>VC++: (see E5KDAQ.h) Unsigned short E5K_SetModuleConfig (unsigned int id, MODULE_CONFIG *mp);</p>
Parameters	<p>id module ID address mp points to a structure MODULE_CONFIG (see E5KDAQ.H)</p>
Return Code	Refer to the Error code .

11.27 E5K_WriteModbusDiscrete

Description	Write data to Modbus discrete (Modbus coil)
Syntax	<p>Visual Basic/VB.Net: (see E5KDAQ.bas/E5KDAQ.vb) Declare/public Function E5K_WriteModbusDiscrete Lib "E5KDAQ.dll" _ (ByVal id As Integer, ByVal startaddr As Integer, _ ByVal counts As Integer, Discrete As Byte) As Integer</p> <p>VC++: (see E5KDAQ.h) Unsigned short E5K_WriteModbusDiscrete (int id, unsigned int startaddr, unsigned int counts, unsigned char Discrete[]);</p>
Parameters	<p>id module ID address Startaddr start address in Modbus coil (0000~FFFF) Counts how many bit be written Discrete[] data buffer be written Discrete[n]=0 or 1 for Modbus coil address startaddr+n (0<=n<counts)</p>
Return Code	Refer to the Error code .

11.28 E5K_WriteModbusRegister

- Description** Write data to Modbus Holding registers
- Syntax** **Visual Basic/VB.Net:** (see [E5KDAQ.bas/E5KDAQ.vb](#))
Declare/public Function E5K_WriteModbusRegister Lib "E5KDAQ.dll" _
 (ByVal id As Integer, ByVal startaddr As Integer, _
 ByVal counts As Integer, regs As Integer) As Integer
- VC++:** (see [E5KDAQ.h](#))
 Unsigned short E5K_WriteModbusRegister (
 Int id,
 unsigned int startaddr,
 unsigned int counts, unsigned int regs[]);
- Parameters**
- | | |
|---------------|--|
| id | module ID address |
| Startaddr | start address in Modbus Holding register(0000~FFFF) |
| Counts | how many register be written |
| regs[] | data buffer be written |
| regs[n]=value | for Modbus holding register address startaddr+n (0<=n<counts) |
- Return Code** Refer to the [Error code](#).

11.29 E5K_ReadModbusRegister

- Description** Read Modbus Holding or Input registers
- Syntax** **Visual Basic/VB.Net:** (see [E5KDAQ.bas/E5KDAQ.vb](#))
Declare/public Function E5K_ReadModbusRegister Lib "E5KDAQ.dll" _
 (ByVal id As Integer, ByVal startaddr As Integer, _
 ByVal counts As Integer, regs As Integer) As Integer
- VC++:** (see [E5KDAQ.h](#))
 Unsigned short E5K_ReadModbusRegister (
 int id,
 unsigned int startaddr,
 unsigned int counts,
 int regs[]);
- Parameters**
- | | |
|-----------|---|
| id | module ID address |
| Startaddr | start address in Modbus Holding or Input register (0000~FFFF) |
| Counts | how many register be read |
| Regs [] | points data buffer |
- Return Code** Refer to the [Error code](#).

11.30 E5K_ReadModbusDiscrete

Description Read Modbus coil or discrete input

Syntax **Visual Basic/VB.Net:** (see [E5KDAQ.bas/E5KDAQ.vb](#))
Declare/public Function E5K_ReadModbusDiscrete Lib "E5KDAQ.dll" _
 (ByVal id As Integer, _
 ByVal startaddr As Integer, _
 ByVal counts As Integer, _
 Discrete As Byte _
) As Integer

VC++: (see [E5KDAQ.h](#))
 Unsigned short E5K_ReadModbusDiscrete(
 int id,
 unsigned int startaddr,
 unsigned int counts,
 unsigned char Discrete[]);

Parameters

id	module ID address
Startaddr	start address in Modbus Holding or Input register (0000~FFFF)
Counts	how many bit be read
Discrete []	points data buffer
	Discrete[n]=0 or 1 of Modbus coil or discrete input address startaddr+n (0<=n<counts)

Return Code

11.31 E5K_SendASCRequestAndWaitResponse

Description Send an ASCII string to and wait for response from module

Syntax **Visual Basic/VB.Net:** (see [E5KDAQ.bas/E5KDAQ.vb](#))
Declare/public Function E5K_SendASCRequestAndWaitResponse Lib "E5KDAQ.dll" _
 (ByVal id As Integer, ByVal asccmd As String, _
 ByVal response As String,
 ByVal rxbufferize As Integer) As Integer

VC++: (see [E5KDAQ.h](#))
 Unsigned short E5K_SendASCRequestAndWaitResponse(
 int id,
 unsigned char asccmd[],
 unsigned char response[],
 unsigned int rxbufferize);

Parameters

id	module ID address
Asccmd	points to ASCII string buffer
Response	points response buffer
Rxbufferize	size of response buffer

Return Code Refer to the [Error code](#).

11.32 E5K_RecvASCII

Description Receive an ASCII string from the module

Syntax Visual Basic/VB.Net: (see [E5KDAQ.bas/E5KDAQ.vb](#))
Declare/public Function E5K_RecvASCII Lib "E5KDAQ.dll" _
 (ByVal id As Integer, _
 ByVal Rxbuffer as String, _
 ByVal bufferSize as integer) as integer

VC++: (see [E5KDAQ.h](#))
Unsigned short E5K_RecvASCII (int id, char Rxbuffer [], unsigned int BufferSize);

Parameters

id	module ID address
Asccmd	points to ASCII string buffer
Rxbuffer	points receive buffer
Buffersize	size of revive buffer

Return Code Refer to the [Error code](#).

11.33 E5K_SendASCII

Description Send an ASCII string to the module

Syntax Visual Basic/VB.Net: (see [E5KDAQ.bas/E5KDAQ.vb](#))
Declare/public Function E5K_SendASCII Lib "E5KDAQ.dll" _
 (ByVal id As Integer, ByVal Txstring as String) as integer

VC++: (see [E5KDAQ.h](#))
Unsigned short E5K_SendASCII (int id, char Txbuffer []);

Parameters

id	module ID address
TX string	points ASCII string buffer

Return Code Refer to the [Error code](#).

11.34 E5K_SendHEXRequestAndWaitResponse

Description Send binary data to and wait for response from module

Syntax **Visual Basic/VB.Net:** (see [E5KDAQ.bas/E5KDAQ.vb](#))
Declare/public Function E5K_SendHEXRequestAndWaitResponse Lib "E5KDAQ.dll" _
(ByVal id As Integer, _
ByRef Txdata As Byte, _
ByVal Rxlen As Integer, _
ByRef Rxdata As Byte, _
ByRef Rxlen As Integer, _
ByVal RxBufsize As Integer _
) As Integer

VC++: (see [E5KDAQ.h](#))

Unsigned short E5K_SendHEXRequestAndWaitResponse(
int id ,
unsigned char cTxData[],
unsigned int wTxlen,
unsigned char cRxdata[],
unsigned int *wRxlen,
unsigned int buffersize);

Parameters

id	module ID address
cTxData []	points to binary data buffer
wTxlen	how many bytes be sent
cRxdata []	points response buffer
*wRxlen	point to buffer to store the number of byte received
Buffersize	size of response buffer

Return Code Refer to the [Error code](#).

11.35 E5K_SendHEX

Description Send a Hex data to the module

Syntax **Visual Basic/VB.Net:** (see [E5KDAQ.bas/E5KDAQ.vb](#))
Declare/public Function E5K_SendHex Lib "E5KDAQ.dll" _
(ByVal id As Integer, Byref Hexdata as Byte, ByVal Datalen as Integer) as integer

VC++: (see [E5KDAQ.h](#))

Unsigned short E5K_SendHex (int id, char Hexdata[], unsigned int Datalen);

Parameters

id	module ID address
Hexdata	points Hex data buffer
Datalen	size of the data buffer

Return Code Refer to the [Error code](#).

11.36 E5K_RecvHEX

- Description** Receive a Hex data from the module
- Syntax** Visual Basic/VB.Net: (see [E5KDAQ.bas/E5KDAQ.vb](#))
 Declare/public Function E5K_RecvHex Lib "E5KDAQ.dll" _
 (ByVal id As Integer, _
 Byref Rxbuffer as String, _
 ByVal bufferSize as integer) as integer
- VC++: (see [E5KDAQ.h](#))
 Unsigned short E5K_RecvHex (int id, char Rxbuffer [], unsigned int BufferSize);
- Parameters**
- | | |
|------------|-------------------------------|
| id | module ID address |
| Asccmd | points to ASCII string buffer |
| Rxbuffer | points receive buffer |
| Buffersize | size of revive buffer |
- Return Code** Refer to the [Error code](#).

11.37 E5K_CalculateCRC16

- Description** Calculate CRC16
- Syntax** Visual Basic/VB.Net: (see [E5KDAQ.bas/E5KDAQ.vb](#))
 Declare/public Function E5K_CalculateCRC16 Lib "E5KDAQ.dll" _
 (bData as byte , byval wLen as integer ,byref wCRC as integer) As Integer
- VC++: (see [E5KDAQ.h](#))
 Unsigned short E5K_CalculateCRC16 (
 unsigned char bData[],
 unsigned int wLen,
 unsigned int *wCRC);
- Parameters**
- | | |
|---------|---------------------------------------|
| bData[] | points to binary data buffer |
| wLen | size of data |
| wCRC | points to buffer to store CRC16 value |
- Return Code** Refer to the [Error code](#).

11.38 E5K_SetLEDControl

- Description** Set on-board control mode (controlled by Module or by user AP)
- Syntax** Visual Basic/VB.Net: (see [E5KDAQ.bas/E5KDAQ.vb](#))
 Declare/public Function E5K_SetLEDControl Lib "E5KDAQ.dll" _
 (ByVal id As Integer, ByVal ControlOption as Integer) As Integer
- VC++: (see [E5KDAQ.h](#))
 Unsigned short E5K_SetLEDControl (int id, char Control Option);
- Parameters**
- | | |
|---------------|--|
| id | module ID address |
| ControlOption | On-board LED control mode. 0: controlled by module, 1: controlled by user AP |
- Return Code** Refer to the [Error code](#).

11.39 E5K_WriteDataToLED

Description	Write data to on-board LED
Syntax	<p>Visual Basic/VB.Net: (see E5KDAQ.bas/E5KDAQ.vb) Declare/public Function E5K_WriteDataToLED Lib "E5KDAQ.dll" _ (ByVal id As Integer, ByVal LedData) As Integer</p> <p>VC++: (see E5KDAQ.h) Unsigned short E5K_WriteDataToLED (int id, unsigned long LedData);</p>
Parameters	id module ID address LedData Data to be written to on-board LED. bit #n=0: LED #n off, bit n=1: LED #n on
Return Code	Refer to the Error code .

11.40 E5K_FlashLED

Description	Force on-board LED to flash
Syntax	<p>Visual Basic/VB.Net: (see E5KDAQ.bas/E5KDAQ.vb) Declare/public Function E5K_FlashLED Lib "E5KDAQ.dll" _ (ByVal id As Integer, ByVal LedMask As Integer, FlashCount As Long) As Integer</p> <p>VC++: (see E5KDAQ.h) Unsigned short E5K_FlashLED (int id, unsigned long LedMask, unsigned int FlashCounts);</p>
Parameters	id module ID address LedMask LED channel mask. bit #n=0: No Flash LED #n, bit n=1: Flash LED #n FlashCounts Flash counts
Return Code	Refer to the Error code .

11.41 E5K_IsValidIPAddress

Description	Check the validity of the specified IP address
Syntax	<p>Visual Basic/VB.Net: (see E5KDAQ.bas/E5KDAQ.vb) Declare/public Function E5K_IsValidIPAddress Lib "E5KDAQ.dll" _ (ByVal zIP As String) As Integer</p> <p>VC++: (see E5KDAQ.h) Unsigned short E5K_IsValidIPAddress (char *zIP);</p>
Parameters	zIP IP address string (such as 192.168.0.21)
Return Code	return 0 if IP is in the same subnet , otherwise not in the same subnet (Refer to the Error code .)

11.42 E5K_IsIPInLocalSubnet

- Description** Is the specified IP address in the default Host IP subnet
- Syntax** Visual Basic/VB.Net: (see [E5KDAQ.bas/E5KDAQ.vb](#))
 Declare/public Function E5K_IsIPInLocalSubnet Lib "E5KDAQ.dll" _
 (ByVal zIP As String) As Integer
- VC++: (see [E5KDAQ.h](#))
 Unsigned short E5K_IsValidIPAddress (char *zIP);
- Parameters** zIP IP address string (such as 192.168.0.21)
- Return Code** return 0 if IP is in the same subnet , otherwise not in the same subnet (Refer to the [Error code](#).)

11.43 E5K_IsIPInLocalSubnetEx

- Description** Is the specified IP address in the specified Host IP subnet (for multiple NIC cards)
- Syntax** Visual Basic/VB.Net: (see [E5KDAQ.bas/E5KDAQ.vb](#))
 Declare/public Function E5K_IsIPInLocalSubnetEx Lib "E5KDAQ.dll" _
 (ByVal zIP As String, ByVal HostIP As String) As Integer
- VC++: (see [E5KDAQ.h](#))
 Unsigned short E5K_IsValidIPAddress (char *zIP,char *HostIP);
- Parameters** zIP IP address string (such as 192.168.0.21)
 HostIP Specifies Host IP
- Return Code** return 0 if IP is in the same subnet , otherwise not in the same subnet (Refer to the [Error code](#).)

11.44 E5K_GetLocalIP

- Description** Get host IP address
- Syntax** Visual Basic/VB.Net: (see [E5KDAQ.bas/E5KDAQ.vb](#))
 Declare/public Function E5K_GetLocalIP Lib "E5KDAQ.dll" _
 (ip0 as byte,ip1 as byte,ip2 as byte,ip3 as byte) as integer
- VC++/BC++Builder: (see [E5KDAQ.h](#))
 Unsigned short E5K_GetLocalIP (char *ip0, char *ip1, char *ip2, char *ip3);
- Parameters** ip0 first IP address byte for an EDAM-5000 that to be connected
 ip1 second IP address byte for an EDAM-5000 that to be connected
 ip2 third IP address byte for an EDAM-5000 that to be connected
 ip3 forth IP address byte for an EDAM-5000 that to be connected
- Return Code** Refer to the [Error code](#).

11.45 E5K_TCPConnect

Description Establish a TCP connection by default Hos IP

Syntax [Visual Basic/VB.Net](#): (see [E5KDAQ.bas/E5KDAQ.vb](#))
Declare/public Function E5K_TCPConnect Lib "E5KDAQ.dll" _
 (ByVal zIP As String, ByVal port As Integer, ByVal iConnectionTimeout As Integer,
 ByVal iSendTimeout As Integer, ByVal iReceiveTimeout As Integer) As long

[VC++/BC++Builder](#): (see [E5KDAQ.h](#))
 SOCKET E5K_TCPConnect (
 char szIP [], u_short port, int iConnectionTimeout,
 int iSendTimeout, int iReceiveTimeout);

Parameters

szIP	Target IP address
port	connection port
iConnectionTimeout	connection timeout value(msec)
iSendTimeout	send timeout value(msec)
iReceiveTimeout	receive timeout value(msec)

Return Code return socket handle or 0 for error (call E5K_GetLastError() to read error code)

11.46 E5K_TCPConnectEx

Description Establish a TCP connection by the specified Host IP

Syntax [Visual Basic/VB.Net](#): (see [E5KDAQ.bas/E5KDAQ.vb](#))
Declare/public Function E5K_TCPConnectEx Lib "E5KDAQ.dll" _
 (ByVal zIP As String, ByVal port As Integer, ByVal iConnectTimeout As Integer, ByVal
 iTxTimeout As Integer, ByVal iRxTimeout As Integer,Byval HostIP as string) As long

[VC++/BC++Builder](#): (see [E5KDAQ.h](#))
 SOCKET E5K_TCPConnect Ex(
 char szIP [], u_short port, int iConnectionTimeout,
 int iSendTimeout, int iReceiveTimeout,char HostIP[]);

Parameters

szIP	Target IP address
port	connection port
iConnectTimeout	connection timeout value(msec)
iTxTimeout	send timeout value(msec)
iRxTimeout	receive timeout value(msec)
Hostip[]	points to Host IP address buffer (such as "192.168.0.10")

Return Code return socket handle or 0 for error (call E5K_GetLastError() to read error code)

11.47 E5K_TCPSendData

- Description** Send data to TCP connection
- Syntax** Visual Basic/VB.Net: (see [E5KDAQ.bas/E5KDAQ.vb](#))
Declare/public Function E5K_TCPSendData Lib "E5KDAQ.dll" _
(ByVal sock As Long, ByVal pdata As Byte, ByVal datalen As Integer) As Integer

VC++/BC++Builder: (see [E5KDAQ.h](#))
Unsigned short E5K_TCPSendData (SOCKET sock, SBYTE *pdata, u_short datalen);
- Parameters** sock TCP socket handle
pdata Points to data buffer
datalen bytes of data
- Return Code** Refer to the [Error code](#).

11.48 E5K_TCPRecvData

- Description** Receive data from TCP connection
- Syntax** Visual Basic/VB.Net: (see [E5KDAQ.bas/E5KDAQ.vb](#))
Declare/public Function E5K_TCPRecvData Lib "E5KDAQ.dll" _
(ByVal sock As Long, ByVal pdata As Byte, ByVal psize As Integer) As Integer
VC++/BC++Builder: (see [E5KDAQ.h](#))
Unsigned short E5K_TCPRecvData (SOCKET sock, char *pdata, unsigned short psize);
- Parameters** sock TCP socket handle
pdata Points to data buffer
psize size of data buffer
- Return Code** Bytes of data received

11.49 E5K_TCPPing

- Description** Ping Specified IP address
- Syntax** Visual Basic/VB.Net: (see [E5KDAQ.bas/E5KDAQ.vb](#))
Declare/public Function E5K_TCPPing Lib "E5KDAQ.dll" _
(ByVal zIP As String, ByVal timeout As Integer) As Integer

VC++/BC++Builder: (see [E5KDAQ.h](#))
Unsigned short E5K_TCPPing (char zIP [], int timeout);
- Parameters** zIP IP address string (such as 192.168.0.123)
Timeout ping timeout (msec)
- Return Code** Refer to the [Error code](#).

11.50 E5K_TCPDisconnect

Description	Release a TCP connection
Syntax	<p>Visual Basic/VB.Net: (see E5KDAQ.bas/E5KDAQ.vb) Declare/public Function E5K_TCPDisconnect Lib "E5KDAQ.dll" _ (ByVal sock As Long) As Integer</p> <p>VC++/BC++Builder: (see E5KDAQ.h) Unsigned short E5K_TCPDisconnect (SOCKET sock);</p>
Parameters	sock TCP connection handle
Return Code	Refer to the Error code .

11.51 E5K_TCPAllDisconnect

Description	Release all TCP connections
Syntax	<p>Visual Basic/VB.Net: (see E5KDAQ.bas/E5KDAQ.vb) Declare/public Function E5K_TCPAllDisconnect Lib "E5KDAQ.dll" _ () As Integer</p> <p>VC++/BC++Builder: (see E5KDAQ.h) Unsigned short E5K_TCPAllDisconnect ();</p>
Parameters	none
Return Code	Refer to the Error code .

11.52 E5K_UDPConnect

Description	Establish a UDP connection by default Host IP												
Syntax	<p>Visual Basic/VB.Net: (see E5KDAQ.bas/E5KDAQ.vb) Declare/public Function E5K_UDPConnect Lib "E5KDAQ.dll" _ (ByVal szIP As String, ByVal port As Integer, ByVal iConnectionTimeout As Integer, ByVal iSendTimeout As Integer, ByVal iReceiveTimeout As Integer, _ Byref in subnet as integer) As long</p> <p>VC++/BC++Builder: (see E5KDAQ.h) SOCKET E5K_UDPConnect (char szIP [], u_short port, int iConnectionTimeout, int iSendTimeout, int iReceiveTimeout, BOOL *in subnet);</p>												
Parameters	<table> <tr> <td>szIP</td> <td>Target IP address</td> </tr> <tr> <td>port</td> <td>connection port</td> </tr> <tr> <td>iConnectionTimeout</td> <td>connection timeout value(msec)</td> </tr> <tr> <td>iSendTimeout</td> <td>send timeout value(msec)</td> </tr> <tr> <td>iReceiveTimeout</td> <td>receive timeout value(msec)</td> </tr> <tr> <td>in subnet</td> <td>return 1, if szIP is in the Host IP subnet ,otherwise not in Host subnet</td> </tr> </table>	szIP	Target IP address	port	connection port	iConnectionTimeout	connection timeout value(msec)	iSendTimeout	send timeout value(msec)	iReceiveTimeout	receive timeout value(msec)	in subnet	return 1, if szIP is in the Host IP subnet ,otherwise not in Host subnet
szIP	Target IP address												
port	connection port												
iConnectionTimeout	connection timeout value(msec)												
iSendTimeout	send timeout value(msec)												
iReceiveTimeout	receive timeout value(msec)												
in subnet	return 1, if szIP is in the Host IP subnet ,otherwise not in Host subnet												
Return Code	return socket handle or 0 for error (call E5K_GetLastError() to read error code)												

11.53 E5K_UDPConnectEx

Description	Establish a UDP connection by the specified Host IP	
Syntax	<p>Visual Basic/VB.Net: (see E5KDAQ.bas/E5KDAQ.vb) Declare/public Function E5K_UDPConnectEx Lib "E5KDAQ.dll" _ (ByVal zIP As String, ByVal port As Integer, ByVal iConnectTimeout As Integer, _ ByVal iTxTimeout As Integer, ByVal iRxTimeout As Integer, _ Byref as in subnet as integer,Byval HostIP as string) As long</p> <p>VC++/BC++Builder: (see E5KDAQ.h) SOCKET E5K_UDPConnectEx (char szIP [], u_short port, int iConnectionTimeout, int iSendTimeout, int iReceiveTimeout,char HostIP[], BOOL *in subnet);</p>	
Parameters	szIP	Target IP address
	port	connection port
	iConnectTimeout	connection timeout value(msec)
	iTxTimeout	send timeout value(msec)
	iRxTimeout	receive timeout value(msec)
	in subnet	return 1,if szIP is in the Host IP subnet ,otherwise not in Host subnet
	Hostip[]	points to Host IP address buffer (such as "192.168.0.10")
Return Code	return socket handle or 0 for error (call E5K_GetLastError() to read error code)	

11.54 E5K_UDPSendData

Description	Send data to UDP connection	
Syntax	<p>Visual Basic/VB.Net: (see E5KDAQ.bas/E5KDAQ.vb) Declare/public Function E5K_UDPSendData Lib "E5KDAQ.dll" _ (ByVal sock As Long, ByRef pdata As Byte, ByVal datalen As Integer) As Integer</p> <p>VC++/BC++Builder: (see E5KDAQ.h) Unsigned short E5K_UDPSendData (SOCKET sock, SBYTE *pdata, u_short datalen);</p>	
Parameters	sock	UDP socket handle
	pdata	Points to data buffer
	datalen	bytes of data
Return Code	Refer to the Error code .	

11.55 E5K_UDPRecvData

Description	Receive data from UDP connection	
Syntax	<p>Visual Basic/VB.Net: (see E5KDAQ.bas/E5KDAQ.vb) Declare/public Function E5K_UDPRecvData Lib "E5KDAQ.dll" _ (ByVal sock As Long, ByRef pdata As Byte, ByVal psize As Integer) As Integer</p> <p>VC++/BC++Builder: (see E5KDAQ.h) Unsigned short E5K_UDPRecvData (SOCKET sock, char *pdata, unsigned short psize);</p>	
Parameters	sock	UDP socket handle
	pdata	Points to data buffer
	psize	size of data buffer
Return Code	Bytes of data received	

11.56 E5K_UDPSendASCStr

- Description** Send ASCII string to UDP connection
- Syntax** Visual Basic/VB.Net: (see [E5KDAQ.bas/E5KDAQ.vb](#))
Declare/public Function E5K_UDPSendASCStr Lib "E5KDAQ.dll" _
(ByVal sock As Long, ByVal strData As String) As Integer
- VC++/BC++Builder: (see [E5KDAQ.h](#))
Unsigned short E5K_UDPSendASCStr (SOCKET sock, SBYTE *StrData);
- Parameters** sock UDP socket handle
StrData Points to string buffer
- Return Code** Refer to the [Error code](#).

11.57 E5K_UDPRecvASCStr

- Description** Receive string data from UDP connection
- Syntax** Visual Basic/VB.Net: (see [E5KDAQ.bas/E5KDAQ.vb](#))
Declare/public Function E5K_UDPRecvASCStr Lib "E5KDAQ.dll" _
(ByVal sock As Long, ByVal strdata As String, ByVal bufsize As Integer) As Integer
- VC++/BC++Builder: (see [E5KDAQ.h](#))
Unsigned short E5K_UDPRecvASCStr(SOCKET sock, char * strdata, unsigned short
bufsize);
- Parameters** sock UDP socket handle
strdata Points to string data buffer
bufsize size of string data buffer
- Return Code** Bytes of string data received

11.58 E5K_UDPDisconnect

- Description** Release a UDP connection
- Syntax** Visual Basic/VB.Net: (see [E5KDAQ.bas/E5KDAQ.vb](#))
Declare/public Function E5K_UDPDisconnect Lib "E5KDAQ.dll" _
(ByVal sock As Long) As Integer
- VC++/BC++Builder: (see [E5KDAQ.h](#))
Unsigned short E5K_UDPDisconnect (SOCKET sock);
- Parameters** sock UDP connection handle
- Return Code** Refer to the [Error code](#).

11.59 E5K_UDPAIIDisconnect

Description Release all UDP connections

Syntax Visual Basic/VB.Net: (see [E5KDAQ.bas/E5KDAQ.vb](#))

Declare/public Function E5K_UDPAIIDisconnect Lib "E5KDAQ.dll" () As Integer

VC++/BC++Builder: (see [E5KDAQ.h](#))

Unsigned short E5K_UDPAIIDisconnect ();

Parameters none

Return Code Refer to the [Error code](#).

11.60 E5K_ReadAIChannelType

Description Read analog channel type

Syntax Visual Basic/VB.Net: (see [E5KDAQ.bas/E5KDAQ.vb](#))

Declare/public Function E5K_ReadAIChannelType Lib "E5KDAQ.dll" _
(ByVal id As Integer, ByVal AIChannel as Integer, ByRef AIType as Integer) As Integer

VC++/BC++Builder: (see [E5KDAQ.h](#))

Unsigned short E5K_ReadAIChannelType (int id, unsigned int AIChannel, unsigned int
*AIType);

Parameters Id target module ID
AIChannel channel number
AIType buffer pointer to store the Channel Type (See sec. 8.2)

Return Code Refer to the [Error code](#).

11.61 E5K_SetAIChannelType

Description Set analog channel type

Syntax Visual Basic/VB.Net: (see [E5KDAQ.bas/E5KDAQ.vb](#))

Declare/public Function E5K_SetAIChannelType Lib "E5KDAQ.dll" _
(ByVal id As Integer, ByVal AIChannel as Integer, ByVal AIType as Integer) As Integer

VC++/BC++Builder: (see [E5KDAQ.h](#))

Unsigned short E5K_SetAIChannelType (int id, unsigned int AIChannel, unsigned int
AIType);

Parameters Id target module ID
AIChannel channel number
AIType buffer pointer to store the Channel Type (See sec.8.2)

Return Code Refer to the [Error code](#).

11.62 E5K_SetSingleChannelColdJunctionOffset

- Description** Set cold junction offset of single analog channel
- Syntax** [Visual Basic/VB.Net](#): (see [E5KDAQ.bas/E5KDAQ.vb](#))
Declare/public Function E5K_SetSingleChannelColdJunctionOffset Lib "E5KDAQ.dll" _
 (ByVal id As Integer, ByVal chno As Integer, ByVal CjOffset as Double) As Integer
- [VC++/BC++Builder](#): (see [E5KDAQ.h](#))
 Unsigned short E5K_SetSingleChannelColdJunctionOffset (int id, unsigned int
 chno,double CjOffset);
- Parameters** Id the target module id
 Chno channel number
 CjOffset channel CJC offset value (such as 0.231)
- Return Code** Refer to the [Error code](#).

11.63 E5K_ReadSingleChannelColdJunctionOffset

- Description** Read cold junction offset of single analog channel
- Syntax** [Visual Basic/VB.Net](#): (see [E5KDAQ.bas/E5KDAQ.vb](#))
Declare/public Function E5K_ReadSingleChannelColdJunctionOffset Lib "E5KDAQ.dll" _
 (ByVal id As Integer, ByVal chno As Integer, ByRef CjOffset as Double) As Integer
- [VC++/BC++Builder](#): (see [E5KDAQ.h](#))
 Unsigned short E5K_ReadSingleChannelColdJunctionOffset (
 int id,
 unsigned int chno,
 double *Cjoffset);
- Parameters** Id the target module id
 Chno channel number
 CjOffset buffer pointer to store channel CJC offset value
- Return Code** Refer to the [Error code](#).

11.64 E5K_ReadMultiChannelColdJunctionOffset

- Description** Read cold junction offset of multiple analog channels
- Syntax** [Visual Basic/VB.Net](#): (see [E5KDAQ.bas/E5KDAQ.vb](#))
Declare/public Function E5K_ReadMultiChannelColdJunctionOffset Lib "E5KDAQ.dll" _
 (ByVal id as Integer, ByVal startch As Integer, Byval counts as integer, Byref
 CjOffset as Double) As Integer
- [VC++/BC++Builder](#): (see [E5KDAQ.h](#))
 Unsigned short E5K_ReadMultiChannelColdJunctionOffset (
 unsigned int id,
 unsigned int startch,
 unsigned int counts,
 double * CjOffset);
- Parameters** Id the target module id
 Startch start channel number
 Counts channels to be read
 CjOffset points to an array to store CJC offset value
- Return Code** Refer to the [Error code](#).

11.65 E5K_SetMultiChannelColdJunctionOffset

- Description** Set cold junction offset of multiple analog channels
- Syntax** [Visual Basic/VB.Net](#): (see [E5KDAQ.bas/E5KDAQ.vb](#))
`Declare/public Function E5K_SetMultiChannelColdJunctionOffset Lib "E5KDAQ.dll" _
(ByVal id As Integer, _
ByVal startch As Integer, _
Byval counts as integer, _
Byref CjOffset As Double _
) As Integer`
- [VC++/BC++Builder](#): (see [E5KDAQ.h](#))
`Unsigned short E5K_SetMultiChannelColdJunctionOffset (
unsigned int id,
unsigned int startch,
unsigned int counts,
double * CjOffset);`
- Parameters**
- | | |
|----------|--|
| Id | the target module id |
| Startch | start channel number |
| Counts | channels to be set |
| CjOffset | points to an array where store channel CJC offset values |
- Return Code** Refer to the [Error code](#).

11.66 E5K_ReadColdJunctionTemperature

- Description** Read cold junction temperature
- Syntax** [Visual Basic/VB.Net](#): (see [E5KDAQ.bas/E5KDAQ.vb](#))
`Declare/public Function E5K_ReadColdJunctionTemperature Lib "E5KDAQ.dll" _
(ByVal id As Integer, ByRef CjTemp as Double) As Integer`
- [VC++/BC++Builder](#): (see [E5KDAQ.h](#))
`Unsigned short E5K_ReadColdJunctionTemperature (int id, double *CJtemp);`
- Parameters**
- | | |
|--------|---------------------------------|
| Id | the target module id |
| CJtemp | CJC temperature (such as 23.67) |
- Return Code** Refer to the [Error code](#).

11.67 E5K_ReadColdJunctionStatus

Description	Read CJC enable/disable status
Syntax	<p>Visual Basic/VB.Net: (see E5KDAQ.bas/E5KDAQ.vb) Declare/public Function E5K_ReadColdJunctionStatus Lib "E5KDAQ.dll" _ (ByVal id As Integer, ByRef Cjs as Byte) As Integer</p> <p>VC++/BC++Builder: (see E5KDAQ.h) Unsigned short E5K_ReadColdJunctionStatus (int id, SBYTE *Cjs);</p>
Parameters	<p>Id the target module id Cjs CJC enable/disable status (0: disabled, 1: enabled)</p>
Return Code	Refer to the Error code .

11.68 E5K_SetColdJunction

Description	Enable/disable CJC
Syntax	<p>Visual Basic/VB.Net: (see E5KDAQ.bas/E5KDAQ.vb) Declare/public Function E5K_SetColdJunction Lib "E5KDAQ.dll" _ (ByVal id As Integer, ByVal Cjs as Byte) As Integer</p> <p>VC++/BC++Builder: (see E5KDAQ.h) Unsigned short E5K_SetColdJunction (int id, SBYTE Cjs);</p>
Parameters	<p>Id the target module id Cjs CJC enable/disable option (0: disable, 1: enable)</p>
Return Code	Refer to the Error code .

11.69 E5K_ReadAIChannelConfig

Description	Read analog channel configuration
Syntax	<p>Visual Basic/VB.Net: (see E5KDAQ.bas/E5KDAQ.vb) Declare/public Function E5K_ReadAIChannelConfig Lib "E5KDAQ.dll" _ (ByVal id As Integer, ByVal chno As Integer, ByRef mConfig As AI_CHANNEL_CONFIG) As Integer</p> <p>VC++/BC++Builder: (see E5KDAQ.h) Unsigned short E5K_ReadAIChannelConfig (Int id, unsigned int chno, AI_CHANNEL_CONFIG * mConfig);</p>
Parameters	<p>Id the target module id chno channel number mConfig points to a structure to store the channel configuration (see E5KDAQ.H about structure CHANNEL_CONFIG)</p>
Return Code	Refer to the Error code .

11.70 E5K_SetAIChannelConfig

- Description** Set analog channel configuration
- Syntax** [Visual Basic/VB.Net](#): (see [E5KDAQ.bas/E5KDAQ.vb](#))
 Declare/public Function E5K_SetAIChannelConfig Lib "E5KDAQ.dll" _
 (ByVal id As Integer, ByVal chno As Integer, mConfig As AI_CHANNEL_CONFIG) As Integer
- [VC++/BC++Builder](#): (see [E5KDAQ.h](#))
 Unsigned short E5K_SetAIChannelConfig (int id, unsigned int
 ch,AI_CHANNEL_CONFIG * mConfig);
- Parameters**
- | | |
|---------|---|
| Id | the target module id |
| chno | channel number |
| mConfig | points to a structure where stores the channel configuration
(see E5KDAQ.H about structure CHANNEL_CONFIG) |
- Return Code** Refer to the [Error code](#).

11.71 E5K_ReadAIBurnOutStatus

- Description** Read analog burnout status
- Syntax** [Visual Basic/VB.Net](#): (see [E5KDAQ.bas/E5KDAQ.vb](#))
 Declare/public Function E5K_ReadAIBurnOutStatus Lib "E5KDAQ.dll" _
 (ByVal id As Integer, ByRef status As Long) As Integer
- [VC++/BC++Builder](#): (see [E5KDAQ.h](#))
 Unsigned short E5K_ReadAIBurnOutStatus (int id, unsigned int *status);
- Parameters**
- | | |
|--------|--|
| Id | the target module id |
| Status | points to a buffer to store the channel burnout status
(Bit #n=0: channel #n is normal, bit #n=1 channel #n is burnout) |
- Return Code** Refer to the [Error code](#).

11.72 E5K_ReadAIAlarmStatus

- Description** Read high/low alarm status of analog channels
- Syntax** [Visual Basic/VB.Net](#): (see [E5KDAQ.bas/E5KDAQ.vb](#))
 Declare/public Function E5K_ReadAIAlarmStatus Lib "E5KDAQ.dll" _
 (ByVal id As Integer, ByRef hialarm As Long, ByRef loalarm As Long) As Integer
- [VC++/BC++Builder](#): (see [E5KDAQ.h](#))
 Unsigned short E5K_ReadAIAlarmStatus (int id, unsigned int *hialarm, unsigned int *loalarm);
- Parameters**
- | | |
|---------|--|
| Id | the target module id |
| Hialarm | points to a buffer to store the channel high alarm status
(bit #n=0: channel #n is normal, bit #n=1 channel #n is high alarm) |
| Loalarm | points to a buffer to store the channel low alarm status
(bit #n=0: channel #n is normal, bit #n=1 channel #n is low alarm) |
- Return Code** Refer to the [Error code](#).

11.73 E5K_SetAIBurnOut

- Description** Enable/disable AI burnout detection
- Syntax** Visual Basic/VB.Net: (see [E5KDAQ.bas/E5KDAQ.vb](#))
Declare/public Function E5K_SetAIBurnOut Lib "E5KDAQ.dll" _
(ByVal id As Integer, ByVal option As Byte) As Integer
- VC++/BC++Builder: (see [E5KDAQ.h](#))
Unsigned short E5K_SetAIBurnOut (int id, SBYTE option);
- Parameters** Id the target module id
Option =0: disable burnout detection, =1: enable burnout detection
- Return Code** Refer to the [Error code](#).

11.74 E5K_ReadAIBurnOut

- Description** Read burnout detection enable/disable status
- Syntax** Visual Basic/VB.Net: (see [E5KDAQ.bas/E5KDAQ.vb](#))
Declare/public Function E5K_ReadAIBurnOut Lib "E5KDAQ.dll" _
(ByVal id As Integer, ByRef option As Byte) As Integer
- VC++/BC++Builder: (see [E5KDAQ.h](#))
Unsigned short E5K_ReadAIBurnOut (int id, SBYTE *option);
- Parameters** Id the target module id
Option points to a buffer to store the burnout detection enable/disable status
=0: burnout detection disabled, =1: burnout detection enabled
- Return Code** Refer to the [Error code](#).

11.75 E5K_SetAIModuleFilter

- Description** Set A/D filter frequency
- Syntax** Visual Basic/VB.Net: (see [E5KDAQ.bas/E5KDAQ.vb](#))
Declare/public Function E5K_SetAIModuleFilter Lib "E5KDAQ.dll" _
(ByVal id As Integer, ByVal Hz as Integer) As Integer
- VC++/BC++Builder: (see [E5KDAQ.h](#))
Unsigned short E5K_SetAIModuleFilter (int id, unsigned int Hz);
- Parameters** Id the target module id
Hz =50: 50Hz, =60: 60Hz, =100 100Hz, =120 120Hz
- Return Code** Refer to the [Error code](#).

11.76 E5K_ReadAIModuleFilter

Description	Read A/D filter frequency
Syntax	Visual Basic/VB.Net: (see E5KDAQ.bas/E5KDAQ.vb) Declare/public Function E5K_ReadAIModuleFilter Lib "E5KDAQ.dll" _ (ByVal id As Integer, ByRef Hz as Integer) As Integer VC++/BC++Builder: (see E5KDAQ.h) Unsigned short E5K_ReadAIModuleFilter (int id, unsigned int *Hz);
Parameters	Id the target module id Hz points to a buffer to store filter frequency =50: 50Hz, =60: 60Hz, =100 100Hz, =120 120Hz
Return Code	Refer to the Error code .

11.77 E5K_SetAIChannelEnable

Description	Enable or disable analog channels
Syntax	Visual Basic/VB.Net: (see E5KDAQ.bas/E5KDAQ.vb) Declare/public Function E5K_SetAIChannelEnable Lib "E5KDAQ.dll" _ (ByVal id As Integer, ByVal AIEnable as Long) As Integer VC++/BC++Builder: (see E5KDAQ.h) Unsigned short E5K_SetAIChannelEnable (int id, unsigned int AIEnable);
Parameters	Id the target module id AIEnable Enable/disable settings bit #n=0: disable channel #n, bit #n=1: enable channel #n
Return Code	Refer to the Error code .

11.78 E5K_ReadAIChannelEnable

Description	Read enable/disable status of analog channels
Syntax	Visual Basic/VB.Net: (see E5KDAQ.bas/E5KDAQ.vb) Declare/public Function E5K_ReadAIChannelEnable Lib "E5KDAQ.dll" _ (ByVal id As Integer, ByRef AIEnable as Long) As Integer VC++/BC++Builder: (see E5KDAQ.h) Unsigned short E5K_ReadAIChannelEnable (int id, unsigned int * AIEnable);
Parameters	Id the target module id AIEnable points to a buffer to store channel Enable/disable settings bit #n=0: channel #n is disabled, bit #n=1: channel #n is enabled
Return Code	Refer to the Error code .

11.79 E5K_ReadAINormalMultiChannel

- Description** Read normal value of the multiple analog channels
- Syntax** **Visual Basic/VB.Net:** (see [E5KDAQ.bas/E5KDAQ.vb](#))
Declare/public Function E5K_ReadAINormalMultiChannel Lib "E5KDAQ.dll" _
 (ByVal id As Integer, ByVal startch As Integer, ByVal counts as Integer, ByRef Altemp As Double) As Integer
- VC++/BC++Builder:** (see [E5KDAQ.h](#))
 Unsigned short E5K_ReadAINormalMultiChannel (
 int id,
 unsigned int startch,
 unsigned int counts,
 double *Altemp);
- Parameters** Id the target module id
 Startch start channel number
 Counts channels
 Altemp points to a array to store AI normal values
 Altemp[0]=normal value of channel #startch
 Altemp[1]=normal value of channel #startch+1
 Altemp[2]=normal value of channel #startch+2
etc
- Return Code** Refer to the [Error code](#).

11.80 E5K_ReadAIMaximumMultiChannel

- Description** Read maximum value of the multiple analog channels
- Syntax** **Visual Basic/VB.Net:** (see [E5KDAQ.bas/E5KDAQ.vb](#))
Declare/public Function E5K_ReadAIMaximumMultiChannel Lib "E5KDAQ.dll" _
 (ByVal id As Integer, ByVal startch As Integer, ByVal counts as Integer, ByRef Altemp As Double) As Integer
- VC++/BC++Builder:** (see [E5KDAQ.h](#))
 Unsigned short E5K_ReadAIMaximumMultiChannel (
 int id,
 unsigned int startch,
 unsigned int count,
 double *Altemp);
- Parameters** Id the target module id
 Startch start channel number
 Counts channels
 Altemp points to a array to store AI maximum values
 Altemp[0]= maximum value of channel #startch
 Altemp[1]= maximum value of channel #startch+1
 Altemp[2]= maximum value of channel #startch+2
etc
- Return Code** Refer to the [Error code](#).

11.81 E5K_ReadAIMinumumMultiChannel

- Description** Read minimum value of the multiple analog channels
- Syntax** **Visual Basic/VB.Net:** (see [E5KDAQ.bas/E5KDAQ.vb](#))
Declare/public Function E5K_ReadAIMinumumMultiChannel Lib "E5KDAQ.dll" _
 (ByVal id As Integer, ByVal startch As Integer, ByVal counts as Integer,
 ByRef Altemp As Double) As Integer
- VC++/BC++Builder:** (see [E5KDAQ.h](#))
 Unsigned short E5K_ReadAIMinumumMultiChannel (
 int id,
 unsigned int startch,
 unsigned int count,
 double *Altemp);
- Parameters** Id the target module id
 Startch start channel number
 Counts channels
 Altemp points to a array to store AI minimum values
 Altemp[0]= minimum value of channel #startch
 Altemp[1]= minimum value of channel #startch+1
 Altemp[2]= minimum value of channel #startch+2
etc
- Return Code** Refer to the [Error code](#).

11.82 E5K_ResetAIMaximum

- Description** Reset analog channel maximum value
- Syntax** **Visual Basic/VB.Net:** (see [E5KDAQ.bas/E5KDAQ.vb](#))
Declare/public Function E5K_ResetAIMaximum Lib "E5KDAQ.dll" _
 (ByVal id As Integer, ByVal restopt As Long) As Integer
- VC++/BC++Builder:** (see [E5KDAQ.h](#))
 Unsigned short E5K_ResetAIMaximum (int id, unsigned int restopt);
- Parameters** Id the target module ID
 Restopt rest mask option
 bit #n=0: no reset maximum value of channel #n
 bit #n=1: reset maximum value of channel #n
- Return Code** Refer to the [Error code](#).

11.83 E5K_ResetAIMinimum

- Description** Reset analog channel minimum value
- Syntax** [Visual Basic/VB.Net](#): (see [E5KDAQ.bas/E5KDAQ.vb](#))
`Declare/public Function E5K_ResetAIMinimum Lib "E5KDAQ.dll" _
 (ByVal id As Integer, ByVal restopts As Long) As Integer`
- [VC++/BC++Builder](#): (see [E5KDAQ.h](#))
Unsigned short E5K_ResetAIMinimum (int id, unsigned int Restopt);
- Parameters** Id the target module ID
Restopt rest mask option
bit #n=0: no reset minimum value of channel #n
bit #n=1: reset minimum value of channel #n
- Return Code** Refer to the [Error code](#).

11.84 E5K_ResetAIHighAlarm

- Description** Reset analog high alarm flag
- Syntax** [Visual Basic/VB.Net](#): (see [E5KDAQ.bas/E5KDAQ.vb](#))
`Declare/public Function E5K_ResetAIHighAlarm Lib "E5KDAQ.dll" _
 (ByVal id As Integer, ByVal restopt As Long) As Integer`
- [VC++/BC++Builder](#): (see [E5KDAQ.h](#))
Unsigned short E5K_ResetAIHighAlarm (int id, unsigned int restopt);
- Parameters** Id the target module ID
Restopt rest mask option
bit #n=0: no reset high alarm flag of channel #n
bit #n=1: reset high alarm flag of channel #n
- Return Code** Refer to the [Error code](#).

11.85 E5K_ResetAILowAlarm

- Description** Reset analog low alarm flag
- Syntax** [Visual Basic/VB.Net](#): (see [E5KDAQ.bas/E5KDAQ.vb](#))
`Declare/public Function E5K_ResetAILowAlarm Lib "E5KDAQ.dll" _
 (ByVal id As Integer, ByVal restopt As Long) As Integer`
- [VC++/BC++Builder](#): (see [E5KDAQ.h](#))
Unsigned short E5K_ResetAILowAlarm (int id, unsigned int restopt);
- Parameters** Id the target module ID
Restopt rest mask option
bit #n=0: no reset low alarm flag of channel #n
bit #n=1: reset low alarm flag of channel #n
- Return Code** Refer to the [Error code](#).

11.86 E5K_ReadAIChannelAverage

- Description** Read analog channel in average status
- Syntax** [Visual Basic/VB.Net](#): (see [E5KDAQ.bas/E5KDAQ.vb](#))
Declare/public Function E5K_ReadAIChannelAverage Lib "E5KDAQ.dll" _
 (ByVal id As Integer, ByRef inavg As Long) As Integer
- [VC++/BC++Builder](#): (see [E5KDAQ.h](#))
 Unsigned short E5K_ReadAIChannelAverage (int id, unsigned int * inavg);
- Parameters** Id the target module id
 Inavg points to a buffer to store the in average status of channels
 bit #n=0: channel #n is not in average
 bit #n=1: channel #n is in average
- Return Code** Refer to the [Error code](#).

11.87 E5K_SetAIChannelAverage

- Description** Set analog channel in average
- Syntax** [Visual Basic/VB.Net](#): (see [E5KDAQ.bas/E5KDAQ.vb](#))
Declare/public Function E5K_SetAIChannelAverage Lib "E5KDAQ.dll" _
 (ByVal id As Integer, ByVal inavg As Long) As Integer
- [VC++/BC++Builder](#): (see [E5KDAQ.h](#))
 Unsigned short E5K_SetAIChannelAverage (int id, unsigned int inavg);
- Parameters** Id the target module id
 inavg in average status of channels
 bit #n=0: set channel #n to be not in average
 bit #n=1: set channel #n to be in average
- Return Code** Refer to the [Error code](#).

11.88 E5K_SetDIChannelConfig

- Description** Set DI channel configuration
- Syntax** [Visual Basic/VB.Net](#): (see [E5KDAQ.bas/E5KDAQ.vb](#))
Declare/public Function E5K_SetDIChannelConfig Lib "E5KDAQ.dll" _
 (ByVal id As Integer, ByVal chn As Integer, config as
 DI_CHANNEL_CONFIG) As Integer
- [VC++/BC++Builder](#): (see [E5KDAQ.h](#))
 Unsigned short E5K_SetDIChannelConfig (int id, unsigned int
 chn, DI_CHANNEL_CONFIG * config);
- Parameters** Id the target module id
 Chn DI channel number
 Config points to a structure buffer where stores the DI configuration parameters (see
 E5KDAQ.H)
- Return Code** Refer to the [Error code](#).

11.89 E5K_ReadDIChannelConfig

Description Read DI channel configuration

Syntax Visual Basic/VB.Net: (see [E5KDAQ.bas/E5KDAQ.vb](#))
 Declare/public Function E5K_ReadDIChannelConfig Lib "E5KDAQ.dll" _
 (ByVal id As Integer, ByVal chn As Integer, config e As DI_CHANNEL_CONFIG) As Integer

VC++/BC++Builder: (see [E5KDAQ.h](#))
 Unsigned short E5K_ReadDIChannelConfig (
 int id ,
 unsigned int chn,
 DI_CHANNEL_CONFIG * config);

Parameters Id the target module id
 Chn DI channel number
 Config points to a structure buffer to store the DI configuration parameters
 (see E5KDAQ.H)

Return Code Refer to the [Error code](#).

11.90 E5K_ReadDIStatus

Description Read digital input status

Syntax Visual Basic/VB.Net: (see [E5KDAQ.bas/E5KDAQ.vb](#))
 Declare/public Function E5K_ReadDIStatus Lib "E5KDAQ.dll" _
 (ByVal id As Integer, ByRef Didata as Long) As Integer

VC++: (see [E5KDAQ.h](#))
 Unsigned short E5K_ReadDIStatus (int id, unsigned long *Didata);

Parameters id module ID address
 Didata points to a 32-bit buffer to store DI status

Return Code Refer to the [Error code](#).

11.91 E5K_ReadDILatch

Description Read digital input latch status

Syntax Visual Basic/VB.Net: (see [E5KDAQ.bas/E5KDAQ.vb](#))
 Declare/public Function E5K_ReadDILatch Lib "E5KDAQ.dll" _
 (ByVal id As Integer, ByRef Dilatch as Long) As Integer

VC++: (see [E5KDAQ.h](#))
 Unsigned short E5K_ReadDILatch (int id, unsigned long *Dilatch);

Parameters id module ID address
 Dilatch points to a 32-bit buffer to store DI latch status

Return Code Refer to the [Error code](#).

11.92 E5K_ClearAllDILatch

- Description** Clear all digital input latch status
- Syntax** Visual Basic/VB.Net: (see [E5KDAQ.bas/E5KDAQ.vb](#))
 Declare/public Function E5K_ClearAllDILatch Lib "E5KDAQ.dll" _
 (ByVal id As Integer) As Integer
- VC++: (see [E5KDAQ.h](#))
 Unsigned short E5K_ClearAllDILatch (int id);
- Parameters** id module ID address
- Return Code** Refer to the [Error code](#).

11.93 E5K_ClearSingleDICounter

- Description** Clear counter of single digital input channel
- Syntax** Visual Basic/VB.Net: (see [E5KDAQ.bas/E5KDAQ.vb](#))
 Declare/public Function E5K_ClearSingleDICounter Lib "E5KDAQ.dll" _
 (ByVal id As Integer, ByVal chan As Integer) As Integer
- VC++: (see [E5KDAQ.h](#))
 Unsigned short E5K_ClearSingleDICounter (int id, unsigned int chan);
- Parameters** id module ID address
 chan channel no.
- Return Code** Refer to the [Error code](#).

11.94 E5K_ReadMultiDICounter

- Description** Clear counter of single digital input channel
- Syntax** Visual Basic/VB.Net: (see [E5KDAQ.bas/E5KDAQ.vb](#))
 Declare/public Function E5K_ReadMultiDICounter Lib "E5KDAQ.dll" _
 (ByVal id As Integer, ByVal startchn As Integer,
 ByVal counts As Integer, counterval As Long) As Integer
- VC++: (see [E5KDAQ.h](#))
 Unsigned short E5K_ReadMultiDICounter (
 int id,
 unsigned int startchn,
 unsigned int counts,
 unsigned long counterval []);
- Parameters** id module ID address
 Startchn channel no.
 Counts how many channels
 Counterval [] points to buffer to store counter value
- Return Code** Refer to the [Error code](#).

11.95 E5K_WriteDO

- Description** Write data to DO channels
- Syntax** Visual Basic/VB.Net: (see [E5KDAQ.bas/E5KDAQ.vb](#))
 Declare/public Function E5K_WriteDO Lib "E5KDAQ.dll"
 (ByVal id As Integer, ByVal dodata As Long) As Integer
- VC++: (see [E5KDAQ.h](#))
 Unsigned short E5K_WriteDO (int id, unsigned long dodata);
- Parameters**
- | | |
|--------|---|
| id | module ID address |
| Dodata | 32-bit DO data, bit-n of dodata represents DO channel n
bit-n=0 inactive, bit-n=1 active |
- Return Code** Refer to the [Error code](#).

11.96 E5K_ReadDOStatus

- Description** Read DO status
- Syntax** Visual Basic/VB.Net: (see [E5KDAQ.bas/E5KDAQ.vb](#))
 Declare/public Function E5K_ReadDOStatus Lib "E5KDAQ.dll" _
 (ByVal id As Integer, ByRef doval As Long) As Integer
- VC++: (see [E5KDAQ.h](#))
 Unsigned short E5K_ReadDOStatus (int id, unsigned long *doval);
- Parameters**
- | | |
|-------|--|
| id | module ID address |
| doval | points to a 32-bit data buffer to store DO status, bit-n of doval represents DO
channel n
bit-n=0 inactive, bit-n=1 active |
- Return Code** Refer to the [Error code](#).

11.97 E5K_SetDOSingleChannel

- Description** Set single DO channel
- Syntax** Visual Basic/VB.Net: (see [E5KDAQ.bas/E5KDAQ.vb](#))
 Declare/public Function E5K_SetDOSingleChannel Lib "E5KDAQ.dll" _
 (ByVal id As Integer, ByVal chno As Integer, ByVal status As Byte) As Integer
- VC++: (see [E5KDAQ.h](#))
 Unsigned short E5K_SetDOSingleChannel (int id, unsigned int chano, unsigned char status);
- Parameters**
- | | |
|--------|--|
| id | module ID address |
| Chano | DO channel number (0~31) |
| Status | status=0 deactivate DO channel, status=1 activate DO channel |
- Return Code** Refer to the [Error code](#).

11.98 E5K_SetDOPulseWidth

Description	Set pulse high/low width of specified DO channel	
Syntax	<p>Visual Basic/VB.Net: (see E5KDAQ.bas/E5KDAQ.vb) Declare/public Function E5K_SetDOPulseWidth Lib "E5KDAQ.dll" _ (ByVal id As Integer, ByVal dochn As Integer, ByVal highwidth as Integer, _ ByVal lowwidth As Integer) As Integer</p> <p>VC++: (see E5KDAQ.h) Unsigned short E5K_SetDOPulseWidth (int id, unsigned int dochn, unsigned int highInterval, unsigned int lowInterval);</p>	
Parameters	id	module ID address
	Dochn	DO channel number (0~31)
	Highwidth	DO pulse high level width in 0.5msec unit
	Lowwidth	DO pulse low level width in 0.5msec unit
Return Code	Refer to the Error code .	

11.99 E5K_ReadDOPulseWidth

Description	Read pulse high/low width of specified DO channel	
Syntax	<p>Visual Basic/VB.Net: (see E5KDAQ.bas/E5KDAQ.vb) Declare/public Function E5K_ReadDOPulseWidth Lib "E5KDAQ.dll" _ ByVal id As Integer, ByVal dochn As Integer, ByRef highwidth As Long, ByRef Lowwidth As Long) As Integer</p> <p>VC++: (see E5KDAQ.h) Unsigned short E5K_ReadDOPulseWidth (int id, unsigned int dochn, unsigned int *highwidth, unsigned int *Lowwidth);</p>	
Parameters	id	module ID address
	Dochn	DO channel number (0~31)
	Highwidth	points to 16-bit buffer to store pulse high width in 0.5msec unit
	Lowwidth	points to 16-bit buffer to store pulse low width in 0.5msec unit
Return Code	Refer to the Error code .	

11.100 E5K_StartDOPulse

- Description** Start DO pulse output
- Syntax** Visual Basic/VB.Net: (see [E5KDAQ.bas/E5KDAQ.vb](#))
 Declare/public Function E5K_StartDOPulse Lib "E5KDAQ.dll" _
 (ByVal id As Integer, ByVal dochn As Integer, ByVal pulses As integer) As Integer
- VC++: (see [E5KDAQ.h](#))
 Unsigned short E5K_StartDOPulse (int id, unsigned int Dochn, unsigned int pulses);
- Parameters**
- | | |
|--------|--------------------------|
| id | module ID address |
| Dochn | DO channel number (0~31) |
| Pulses | how many pulses |
- Return Code** Refer to the [Error code](#).

11.101 E5K_StartMultipleDOPulse

- Description** Start/Stop DO pulse output of multiple DO channels
- Syntax** Visual Basic/VB.Net: (see [E5KDAQ.bas/E5KDAQ.vb](#))
 Declare/public Function E5K_StartMultipleDOPulse Lib "E5KDAQ.dll" _
 (ByVal id As Integer, ByVal dochn As Integer, ByVal DOchbit as long,ByRef pulses As integer)
 As Integer
- VC++: (see [E5KDAQ.h](#))
 Unsigned short E5K_StartMultipleDOPulse (int id, unsigned long Dochn, unsigned int pulses[]);
- Parameters**
- | | |
|----------|---|
| id | module ID address |
| Dochn | DO channel start/stop pulse output bit (0~31) |
| Pulses[] | bit n=1 start channel n ,bit n=0 stop channel n
points to pulses array |
- Return Code** Refer to the [Error code](#).

11.102 E5K_StopDOPulse

- Description** Stop DO pulse output of single channel
- Syntax** Visual Basic/VB.Net: (see [E5KDAQ.bas/E5KDAQ.vb](#))
 Declare/public Function E5K_StopDOPulse Lib "E5KDAQ.dll" _
 (ByVal id As Integer, ByVal dochn As Integer) As Integer
- VC++: (see [E5KDAQ.h](#))
 Unsigned short E5K_StopDOPulse (int id, unsigned int dochn);
- Parameters**
- | | |
|-------|--------------------------|
| id | module ID address |
| Dochn | DO channel number (0~31) |
- Return Code** Refer to the [Error code](#).

11.103 E5K_ReadDOPulseCount

Description	Read pulse count value. The pulse count value will start decreasing after calling E5K_StartDOPulse () or E5K_StartMultipleDOPulse ()	
Syntax	<p>Visual Basic/VB.Net: (see E5KDAQ.bas/E5KDAQ.vb) Declare/public Function E5K_ReadDOPulseCount Lib "E5KDAQ.dll" _ (ByVal id As Integer, ByVal dochn As Integer, ByRef counts As Integer) As Integer</p> <p>VC++: (see E5KDAQ.h) Unsigned short E5K_ReadDOPulseCount (Int id, unsigned int dochn, unsigned int *counts);</p>	
Parameters	id dochn counts	module ID address DO channel number (0~31) point to 16-bit buffer to store pulse counter value
Return Code	Refer to the Error code .	

11.104 E5K_SetDOPowerOnValue

Description	Set DO power-on value	
Syntax	<p>Visual Basic/VB.Net: (see E5KDAQ.bas/E5KDAQ.vb) Declare/public Function E5K_SetDOPowerOnValue Lib "E5KDAQ.dll" _ (ByVal id As Integer, ByVal poweronvalue As Long) As Integer</p> <p>VC++: (see E5KDAQ.h) Unsigned short E5K_SetDOPowerOnValue (int id, unsigned long poweronvalue);</p>	
Parameters	id Poweronvalue	module ID address 32-bit DO power-on value
Return Code	Refer to the Error code .	

11.105 E5K_ReadDOPowerOnValue

Description	Read DO power-on value	
Syntax	<p>Visual Basic/VB.Net: (see E5KDAQ.bas/E5KDAQ.vb) Declare/public Function E5K_ReadDOPowerOnValue Lib "E5KDAQ.dll" _ (ByVal id As Integer, ByRef Dopoweron as Long) As Integer</p> <p>VC++: (see E5KDAQ.h) Unsigned short E5K_ReadDOPowerOnValue (Int id, unsigned long *PowerOnValue);</p>	
Parameters	id Poweronvalue	module ID address points to a 32-bit buffer to store DO power-on value
Return Code	Refer to the Error code .	

11.106 E5K_ReadDIOActiveLevel

Description Read DI/DO active level options

Syntax **Visual Basic/VB.Net:** (see [E5KDAQ.bas/E5KDAQ.vb](#))
Declare/public Function E5K_ReadDIOActiveLevel Lib "E5KDAQ.dll" _
 (ByVal id As Integer, ByRef DIActiveoption as Byte, _
 ByRef DOActiveoption as Byte) As Integer

VC++: (see [E5KDAQ.h](#))
 Unsigned short E5K_ReadDIOActiveLevel (
 int id,
 unsigned char *DIActiveoption,
 unsigned char *DOActiveoption);

Parameters id module ID address
 DIActiveoption points to 8-bit buffer to store DI active status option 0 or 1 (see Table 2)
 DOActiveoption points to 8-bit buffer to store DO active status option 0 or 1 (Table 1)

Return Code Refer to the [Error code](#).

11.107 E5K_SetDIOActiveLevel

Description Set DI/DO active level options

Syntax **Visual Basic/VB.Net:** (see [E5KDAQ.bas/E5KDAQ.vb](#))
Declare/public Function E5K_SetDIOActiveLevel Lib "E5KDAQ.dll" _
 (ByVal id As Integer, ByVal DIActiveoption as Byte, _
 ByVal DOActiveoption as Byte) As Integer

VC++: (see [E5KDAQ.h](#))
 Unsigned short E5K_SetDIOActiveLevel (
 int id,
 unsigned char DIActiveoption,
 unsigned char DOActiveoption);

Parameters id module ID address
 id module ID address
 DIActiveoption DI active state option 0 or 1 (see Table 2)
 DOActiveoption DO active states option 0 or 1 (see Table 2)

Return Code Refer to the [Error code](#).

Module Name	DI Active Option	Description
EDAM-5060	0	Active state ,if input open or high voltage Inactive state ,if input short or low voltage
	1	Active state ,if input short or low voltage Inactive state ,if input open or high voltage

Table 2

Module Name	DO Active Option	Description
EDAM-5060	0	Active state ,if relay close Inactive state ,if relay open
	1	Active state ,if relay open Inactive state ,if relay close

Table 3

Chapter 12 E5KDAQ.DLL Error Code

Error Code	Description
00	No Error
01	Device not supported
02	Device is not existed
03	Device driver not activated
04	Device driver open fail
05	Device time out
06	Device response Error
07	Invalid driver version
08	Invalid ID Number
09	Device ID overlapped
10	Invalid interface type
11	Invalid Pass Word or password not be verified
12	Invalid ASCII Command
13	Interrupt Already enabled
14	No Interrupt Data
15	Arguments Out Of Range
16	Invalid Port Number
17	Invalid DO Data
18	Invalid Digital Channel Number
19	Invalid Timer Value
20	Invalid Timer Mode
21	Invalid Counter Number
22	Invalid Counter Value
23	Invalid Counter Mode
24	Invalid A/D Filter Type
25	Invalid A/D Mode
26	Invalid A/D channel number
27	Invalid A/D Gain
28	Invalid A/D Range
29	Invalid A/D count Value
30	Invalid A/D Scan Rate
31	A/D FIFO Half Not Ready
32	Invalid D/A channel number
33	Invalid D/A Value
34	Invalid Debounce Mode
35	Invalid Debounce Time
36	Invalid Modbus Function
37	Invalid Modbus Start Address
38	Modbus Address Out Of Range
39	Modbus Range over 32 Channel
40	Winsck2 Not Opened
41	Windows winsock2 start up error
42	Invalid IP address
43	Can Not Create TCP Socket
44	Can Not Create UDP Socket
45	Can Not Set TCP/IP Timeout
46	Can Not Send Package To Destination
47	No Package Received Until Timeout
48	Unable To Read Stream Data
49	No Connection To Remote IP Address
50	Alarm Event Buffer Empty
51	Stream Event Buffer Empty
52	Unable To Allocate Memory
53	Can Not Ping Remote IP Address

EDAM-5000 User's Manual

54	ASCII Check Sum error
55	Mosbus CRC error
56	IP not in then subnet
57	COMM port already open
58	No enough buffer size to receive data
59	Invalid parameters
60	USB data over 1024 bytes
61	Invalid Host IP
62	Invalid Stream IP
63	Invalid alarm IP
59	Error Code Out of Range

Chapter 13 Event/Stream Interrupt structure

13.1 Event Interrupt Structure

```

Typedef struct EVENT_INTERRUPT_INFO
{
    unsigned int    szID;                //the ID address which cause the alarm interrupt
    unsigned int    wIntType;           //0= DI interrupt,1= AD_INT_TYPE
    unsigned int    wChno;             //Event channel number
    unsigned int    wStatus;           //0 for low to high interrupt for DI or high alarm for AI channel
                                        //1 for high to low interrupt for DI or low alarm for AI channel
    double fAddata;                    //AD data if AD alarm occurred
} DEVICE_INTERRUPT_INFO;

```

When event occurred, E5KDAQ.DLL will transfer argument with structure **EVENT_INTERRUPT_INFO** to callback function

13.2 Stream Interrupt Structure

```

Typedef struct STREAM_INTERRUPT_INFO
{
    Unsigned int    wszID;                //the ID address which cause the alarm change
    Unsigned long   dwDi;                 //digital input status
    Unsigned long   dwDiLatch;           //digital input latch status
    Unsigned long   dwDiCount[32];       //digital input counter value
    Unsigned long   dwDo;                 //digital output status
    double          fAiNorValue[17];     //analog input normal value
    double          fAiMaxValue[16];    //analog input maximum value
    double          fAiMinValue[16];    //analog input minimum value
    unsigned int    wAiHighAlarmstatus;  //analog input high alarm status
    unsigned int    wAiLowAlarmstatus;   //analog input low alarm status
    unsigned int    wAiBurnOut ;         //analog input burn-out status(5019,EDAM5015 only)
    double          fCJCTemperature;     //cold junction temperature in 0.1C unit (5019 only)
    double          fAoValue[16];        //analog output value
} STREAM_INTERRUPT_INFO;

```

When received active-stream data, E5KDAQ.DLL will transfer argument with structure **STREAM_INTERRUPT_INFO** to callback function

Chapter 14 E5KDAQ ActiveX Control

14.1 Properties Of E5KDSAQ ActiveX Control

Name	Type	Description	Model(s)
AIChannelIndex	Short	Specifies the analog input channel to perform other AI properties read/write operation.	5015,,5017,5019
AINormalValue	Double	Normal voltage of specifies the analog channel	5015,5017,5019
AIMaximumValue	Double	Maximal voltage of specifies the analog channel	5015,5017,5019
AIMinimumValue	Double	Minimal voltage of specifies the analog channel	5015,5017,59019
AILowAlarmStatus	Long	Return the low alarm status of specifies the analog channel (1=Alarm occurred/ 0=No alarm)	5015,5017,5019
AIHighAlarmStatus	Long	Return the high alarm status of specifies the analog channel (1=Alarm occurred/ 0=No alarm)	5015,5017,5019
AIBurnOutStatus	Long	Return the Burnout status of specifies the analog channel (1=open/ 0=normal)	5015,5019
AIChannelEnable	Long	Enable/disable AI channels	5015,5017,5019
AIChannels	Long	Return the total AI channels of model	
AOChannelIndex	Short	Specifies the analog output channel to perform other properties read/write operation.	Reserved
AOChannels	Long	Return the total AO channels of model	
AOValue	Double	Set the analog output voltage	All models
AIColdJunction	Double	Return the cold junction temperature	reserved
AlarmEventADValue	Double	Return the alarm AD value	5015,50175019
AlarmEventChannel	Short	Return the alarm channel number	5015,5017,5019
AlarmEventID	Short	Return the ID address of alarm model	5015,5017,5019
AlarmEventIP	String	Return the IP address of alarm model	All models
AlarmEventStatus	Short	Return 1 if AD low alarm or DI high to low return 0 if AD high alarm or DI low to high	All models
AlarmEventType	Short	Return 1 if AD type alarm event occurred return 0 if DI type alarm event occurred	All models
ChecksumCRC	Boolean	Enable/disable CheckSum/CRC	All models
DIChannelIndex	Short	Specifies the digital input channel to perform other DI properties read/write operation.	5017,5019,5028, 5029,5060
DIChannels		Return the total DI channels of model	5017,5019,5028, 5029,5060
DIcounterValue	Long	Return the counting value for the specified DI channel which functions in "Count/Frequency mode"	5017,5019,5028, 5029,5060
DILatchStatus	Long	Return the latch status for the specified DI channel which functions in "Lo-Hi/Hi-Lo latch mode" (1=Latched/ 0=No latched)	5017,5019,5028, 5029,5060
DIStartCount	Boolean	Start/stop counting for the specified DI channel which functions in "Count/Frequency mode" (True=Start/ 0=Stop)	5017,5019,5028, 5029,5060
DIStatus	Long	Return the status for the specified DI channel which functions in "DI mode" (1=Active/ 0=Inactive)	5017,5019,5028, 5029,5060
DOChannelIndex	Short	Specifies the digital output channel to perform other DO properties read/write operation.	5017,5019,5028, 5029,5060
DOChannels	Short	Return the total DO channels of model	5017,5019,5028, 5029,5060

EDAM-5000 User's Manual

Name	Type	Description	Model(s)
DOOulseCounts	Long	Set the output count value for the specified DO channel which functions in "Pulse output mode"	5017,5019,5028,5029,5060
DOStatus	Long	Return/set the status for the specified DO channel which functions in "D/O mode" (1=Active/ 0=Inactive)	5017,5019,5028,5029,5060
COMBaudRate	Long	Return/set COM port baud rate	All models
CommunicationType	Short	Return/set communication interface	All models
StreamEventID	Short	Return ID address of module which generate stream data	All models
StreamIP	String	Return IP address of module which generate stream data	All models
Version	String	Return the version of ActiveX control (E5KDAQ.OCX)	All models
LastError	Short	Return the Error code of operation	All models
LastErrorDescription	String	Return the error description	All models
MoudleID	Short	Return the module ID number	All models
ModuleIP	String	Set the remote module IP address	All models
ModuleName	String	Return the module name	All models
ConnectionTimeout	Long	Return or set the TCP/IP Timeout (ms)	All models
ReceiveTimeout	Long	Return or set the TCP/IP or COM receive Timeout (ms)	All models
SendTimeout	Long	Return or set the TCP/IP Send Timeout (ms)	All models
UpdatePeriod	Long	Return/set data update time period(ms)	All models

14.2 Methods of E5KDAQ ActiveX Control

Name	Arguments	Return	Description
Open	None	None	Open E5kDAQ.OCX to start operation (Must be called before accessing properties at run time)
Close	None	None	Close E5KDAQ.OCX (Must be called before terminating the APP)
ReadAlarmEventData	None	Boolean	Return the status of alarm data TRUE=alarm data ready in queue, FLASE=no alarm data
ReadStreamData	None	Boolean	Return the status of stream data TRUE=stream data ready in queue, FLASE=no stream data
SendASCII	string		Send ASCII command
RecvASCII	None		Receive ASCII command
SendHEX	short Buffer[] short length	None	Send Hex data in buffer[]
RecvHEX	short Buffer[] short buffer size	Integer	Receive hex data and store into buffer[] return the data length
StartAlarmEvent	None	Long	Start alarm interrupt return 0 if error occurred, or handle of interrupt
StartStreamEvent	None	Long	Start stream interrupt return 0 if error occurred, or handle of interrupt

14.3 Events of E5KDAQ ActiveX control

Name	Arguments	Return	Description
OnError	short ErrCode(out) string Errmsg(out)	None	be called when error occurred

Chapter 15 EDAM 5000 Utility Overview

The EDAM5000 Utility software offers a graphical interface that helps you configure the EDAM-5000 modules. It is also very convenient to test and monitor your remote DAQ system. The following guidelines will give you some brief instructions on how to use this Utility.

- Main Menu
- Network Setting
- Adding Remote Station
- Security setting
- I/O Module Configuration
- Alarm Setting
- I/O Module Calibration
- Security Setting
- Terminal emulation
- Data/Event Stream

15.1 Main Menu

Double Click the icon of EDAM-5000 Utility shortcut, the Operation screen will pop up as follow.

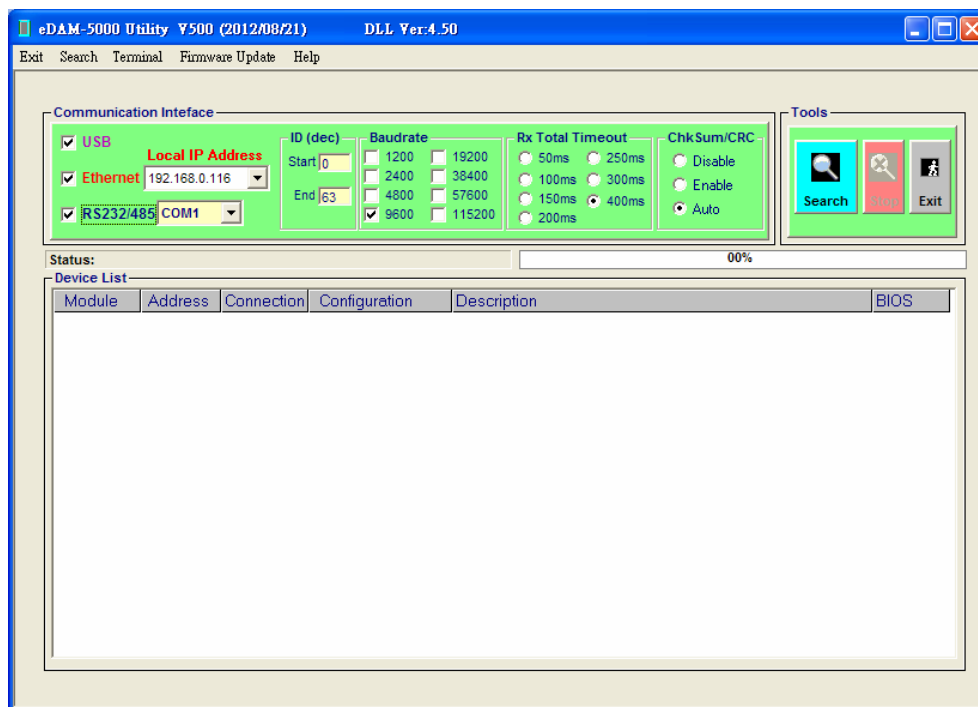

Figure - 1

The top of the operation screen consists of a function menu and a tool bar for user's commonly operating functions.

15.2 Communication Interface Settings

There are three interfaces that EDAM5000 modules can be connected to

- **USB** option : Enable/disable USB connection
- **Ethernet** option : Enable/disable Ethernet connection
- **RS232/485** option : Enable/disable Serial port connection

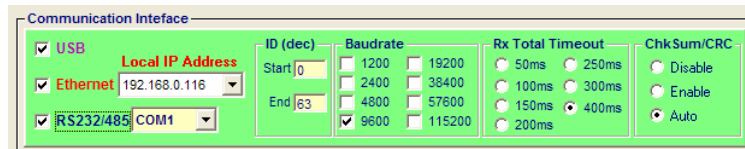

Figure - 2

- **Local IP Address** :EDAM5000 supports multiple Ethernet cards (multiple host IP addresses). The EDAM5000 module(s) can connect to one of the Ethernet card's network.

Note:

1. Each Ethernet card should have different IP subnet
2. If the Ethernet cards are in the same subnet, the combo box-structure display area will only appeal with the highest priority IP addresses
3. For example, Assume there are three Ethernet cards installed in Host with the IP addresses **192.168.0.123**(highest priority IP in 192.168.0.xxx subnet), **192.168.1.191** and **192.168.0.34**. The Combobox-structure display area will only appeal with **192.168.0.123** and **192.168.1.191**

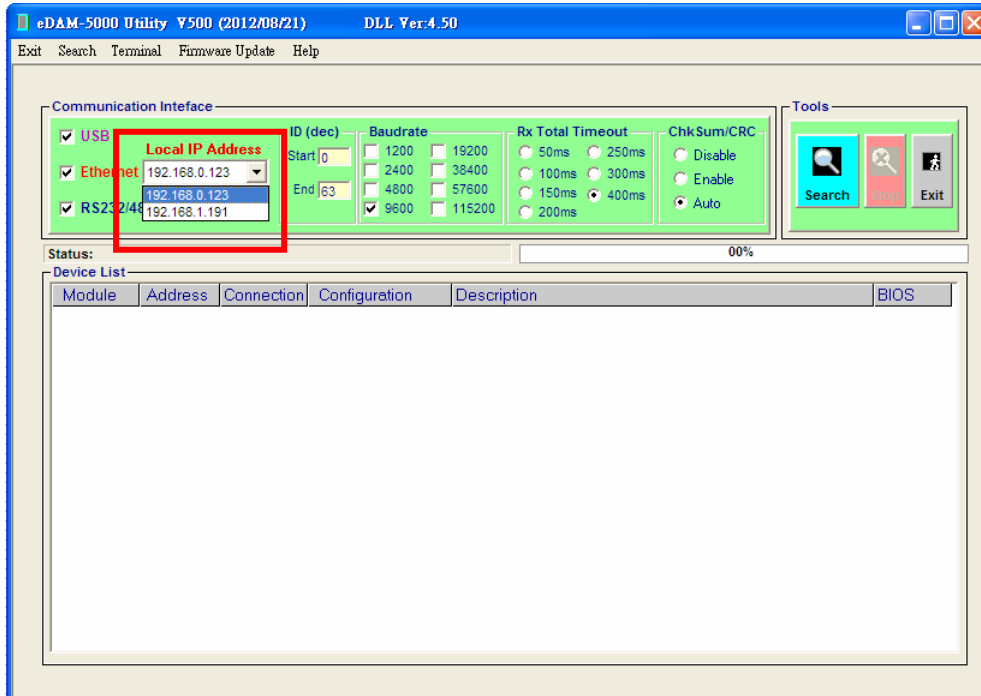

Figure - 3

- **ID Range** :Set start and end ID number range for searching (**RS232/85 only**)
- **Baud rate** :Select COM baud rate(**RS232/85 only**)
- **RX Total Timeout** :Select Receive timeout(**RS232/85 and Ethernet only**)
- **ChkSum/CRC** :Enable/disable/auto Check sum or CRC check (**RS232/485 only**)

15.3 Tool Bar

There are three push buttons(**Search**, **Stop**, **Exit**) in the tool bar.

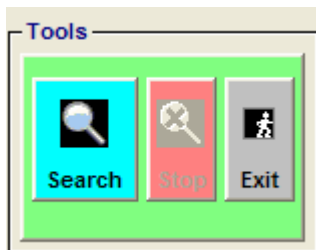

Figure - 4

- Search** : Click this button to start searching all EDAM-5000 I/O module(s) on the specified interface(s) (**USB**, **Ethernet**, **COM**) automatically. Then the Grid-structure display area will appeal with the searched units and the relative configuration.

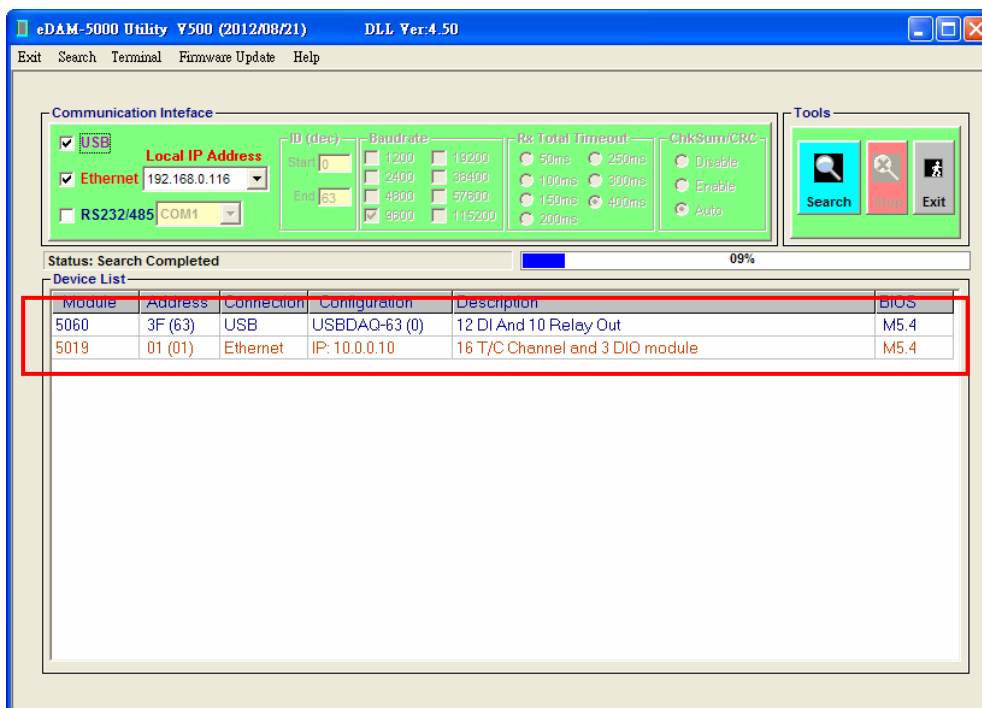
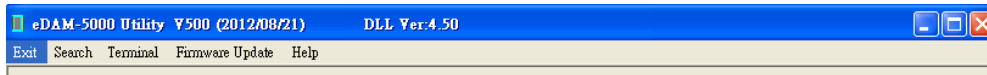

Figure - 5

- Stop** : Click this button to stop searching
- Exit** : Click this button to Exit this Utility program.

15.4 Menu Bar



- **Exit :**
Exit this Utility program.
- **Search :**
Click this to start searching all EDAM-5000 I/O module(s) on the specified interface(s) (**USB, Ethernet, COM**) automatically. Then the Grid-structure display area will appear with the searched units and the relative configuration. (See Figure - 5)
- **Terminal :**
Call up the operation screen of Terminal emulation to do the request / response command execution.

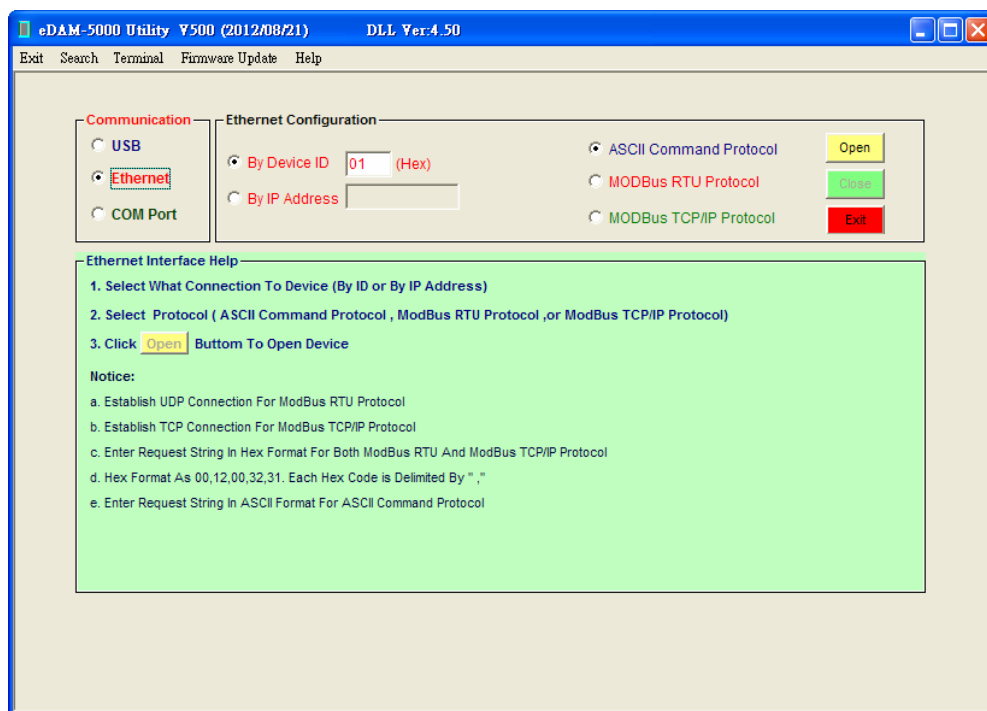

Figure - 6

- **Communication:** Select communication interface to do the request / response command execution
- **Ethernet Configuration:** Connect to target by module ID number or by IP address
- **ASCII command protocol:** do request / response command with ASCII protocol
- **Modbus RTU protocol:** do request / response command with Modbus RTU protocol
- **Modbus TCP/IP protocol:** do request / response command with Modbus /TCP protocol
- **Open button:** Connects to target
- **Close button:** Disconnects to target
- **Exit button:** Exit terminal tool

- **Firmware Update:** Update Firmware through **USB** connection.

The EDAM-5000 utility provides on-board firmware update tool that can help you to update firmware through USB interface quickly.

Please see 15.10 to understand the detail procedures about "Firmware update" tool.

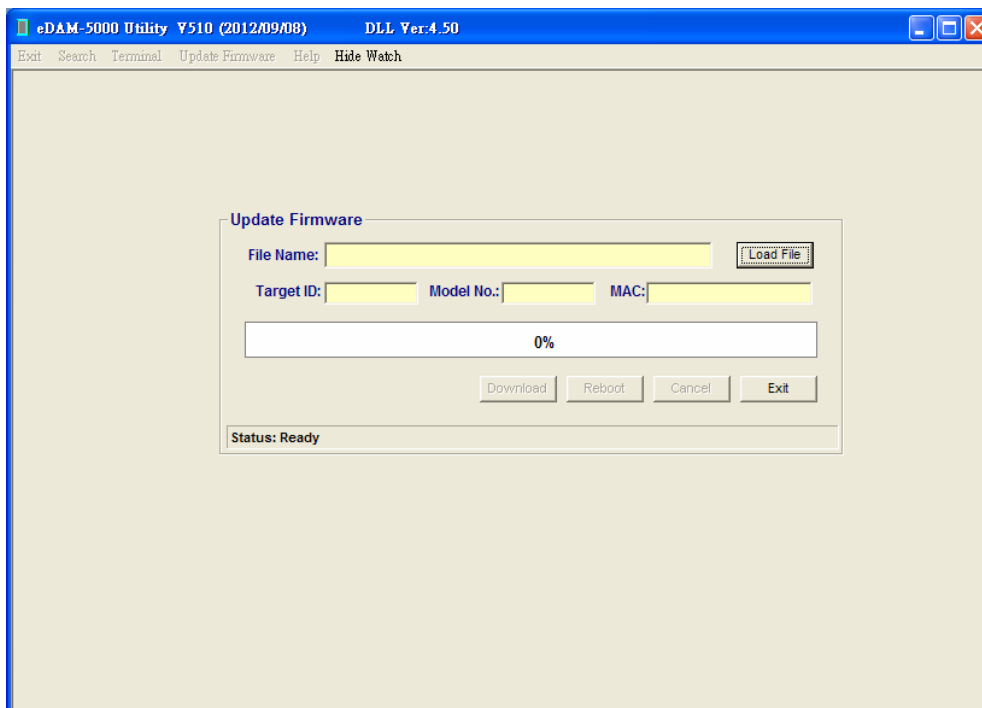

Figure - 7

- **Load File button:** Load firmware file
 - **DownLoad button:** Search target and start download firmware to target
 - **Cancel button:** Stop download firmware process
 - **Exit button:** Exit this function
-
- **Help:** EDAM5000 User's manual

15.5 EDAM5000 module configuration

Since Utility software detects the EDAM-5000 on the specified interface, user can begin to setup each unit. Double click any one I/O module listed on the grid-structure display area and entry the correct password (for Ethernet Interface only). The module basic configuration table is listed as shown in for setting

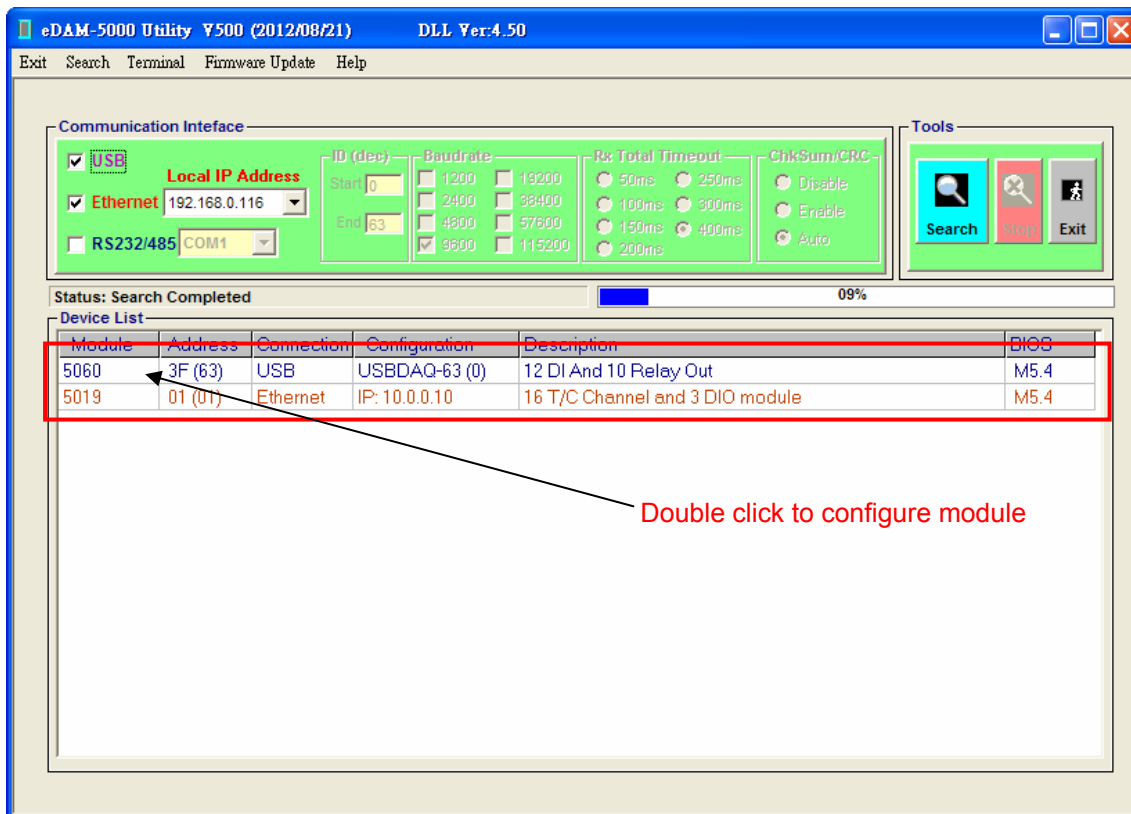

Figure - 8

15.6 EDAM5060 Settings

15.6.1 Module settings tab

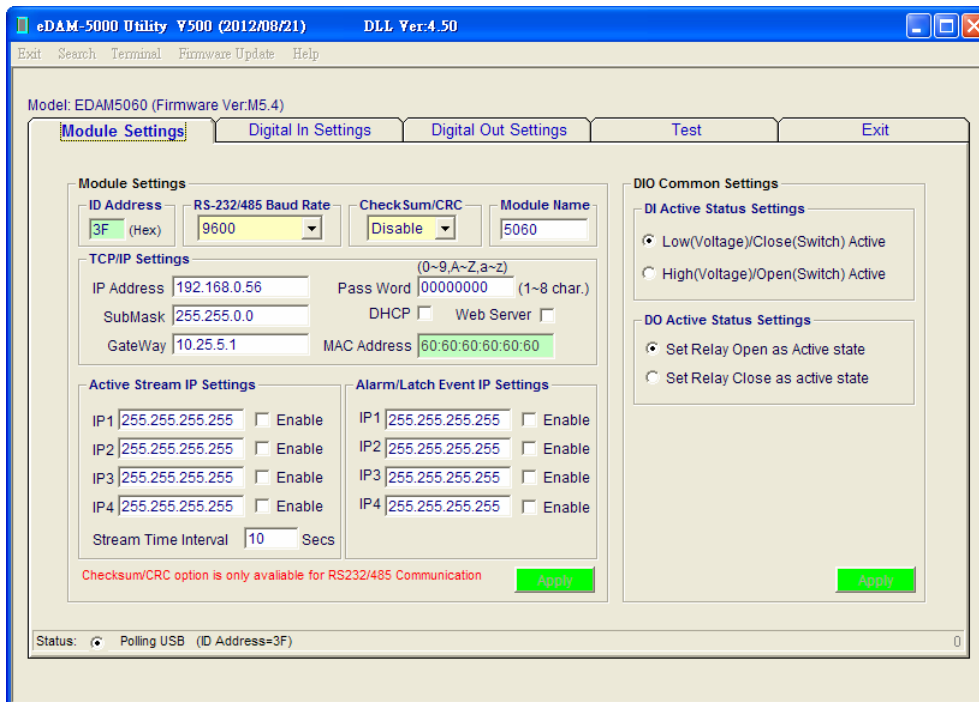

Figure - 9

- **MAC Address:**
The Ethernet address and needs no further configuration.
- **IP Address, Subnet Mask, and Default Gateway:** (default 10.0.0.1, 255.0.0.0 and 0.0.0.0)
The IP address identifies your EDAM-5000 devices on the global network. Each EDAM-5000 has same default IP address **10.0.0.1**. Therefore, *please do not initial many EDAM-5000 at the same time to avoid the Ethernet collision*. If you want to configure the EDAM-5000 in the host PC's dominating network, only the IP address and Subnet Mask will need to set (The host PC and EDAM Ethernet I/O must belong to same subnet Mask).
- **DHCP:** (default Enabled)
Allow you to get IP address from the DHCP servo without setting IP address by manual.
- **Web Server:** (default Enabled)
Allow you monitor and control I/O status on EDAM-9000 modules remotely through web browser.
- **Module ID:** (default 01)
Unique ID number of module can be set by DIP switch on the back side of module (See Help)
- **Password:** (default 00000000)
Allow you to change the password of the module (needed for Ethernet connection only)
- **Stream/Event IP:**
Set Stream /Event data Destination IP
- **Stream/Event Enable Setting:** (default all disabled)
Enable/disable Stream and Event functions
- **Stream time interval:** (default 10 sec)
Set time interval for sending stream data
- **DI active state settings:**
Set DI active state (High input active or low input active)
- **DO active state settings:**
Set DO output active state (High/open output active or low output active)

15.6.2 Digital input settings tab

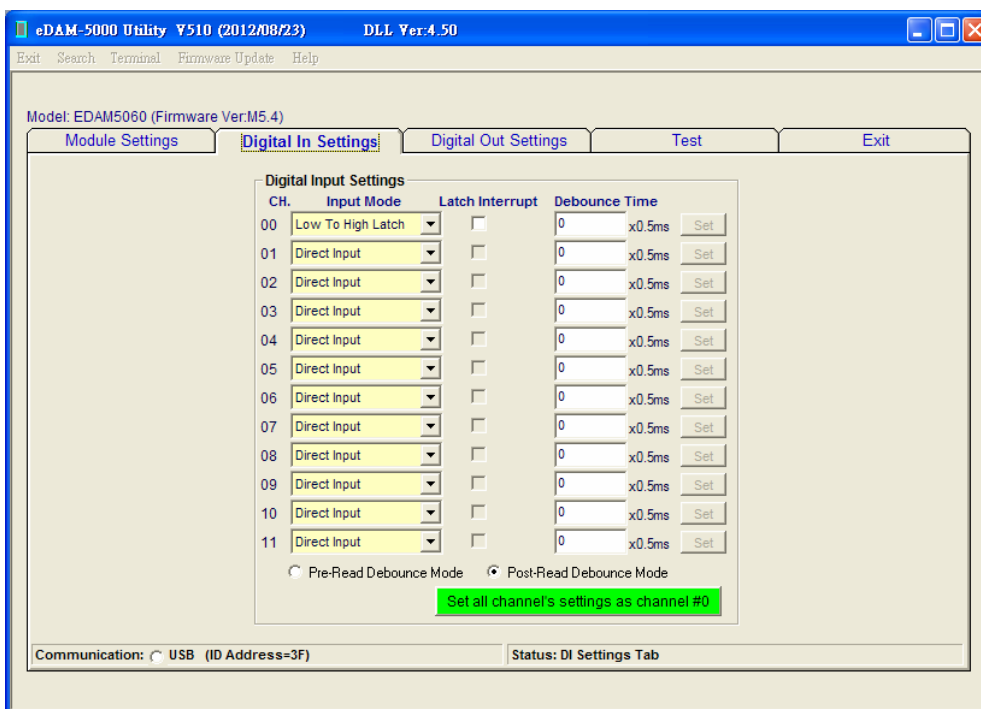

Figure - 10

- **DI channel Input Mode:**
Direct input ,counter, low to high latch, high to low latch, frequency mode
- **Latch Interrupt:**
Enable/Disable DI latch interrupt (USB connection only)
- **Debounce time:**
Set DI input debounce time (0~65535). =0 no debounce
- **Select Pre-read debounce/Post read debounce mode (see Figure - 11)**

Pre-read mode

The device read DI state immediately when DI state-changed and then delay 5000 msec to filter all other states changed in this time interval(A/B/C/D states are all ignored by device)

Post-read mode

The bounce detection is started when DI state-changed and then read final DI state after 5000 msec delay reached

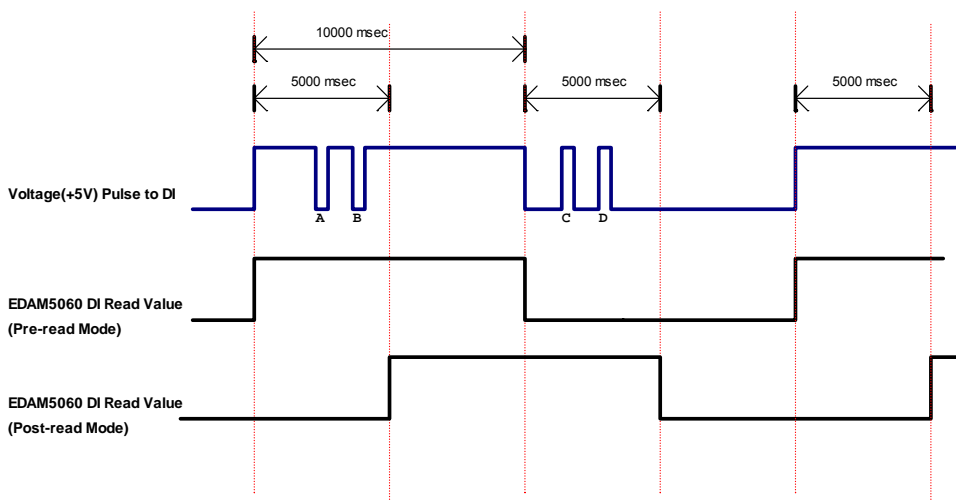

Figure - 11

- **Set all channels settings as channel 0**
Configure all channel settings as channel 0 settings

15.6.3 Digital output settings tab

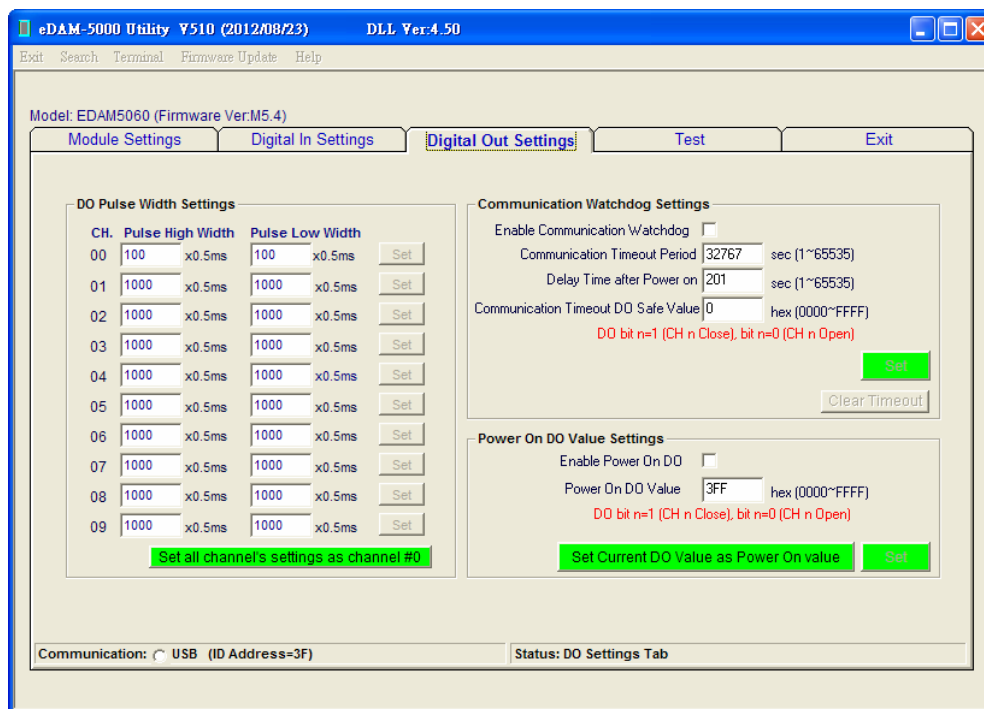

Figure - 12

- **DO pulse width:**
Set high level width and low level width for DO pulse output operation
- **Communication watchdog:**
 - **Enable/disable communication watchdog**
If there are no data received from host When communication timeout is reached, The DO will be set to specified safe value.
 - **Communication timeout period**
Set Communication timeout value
 - **Delay time after power-on**
The delay time to start communication watchdog function after module reboot
 - **Communication timeout DO safe value**
DO value when communication timeout is reached
- **Enable power-on DO:**
DO default value after module reboot
- **Power-on DO value:**
Set Power-on DO value

15.6.4 Test tab

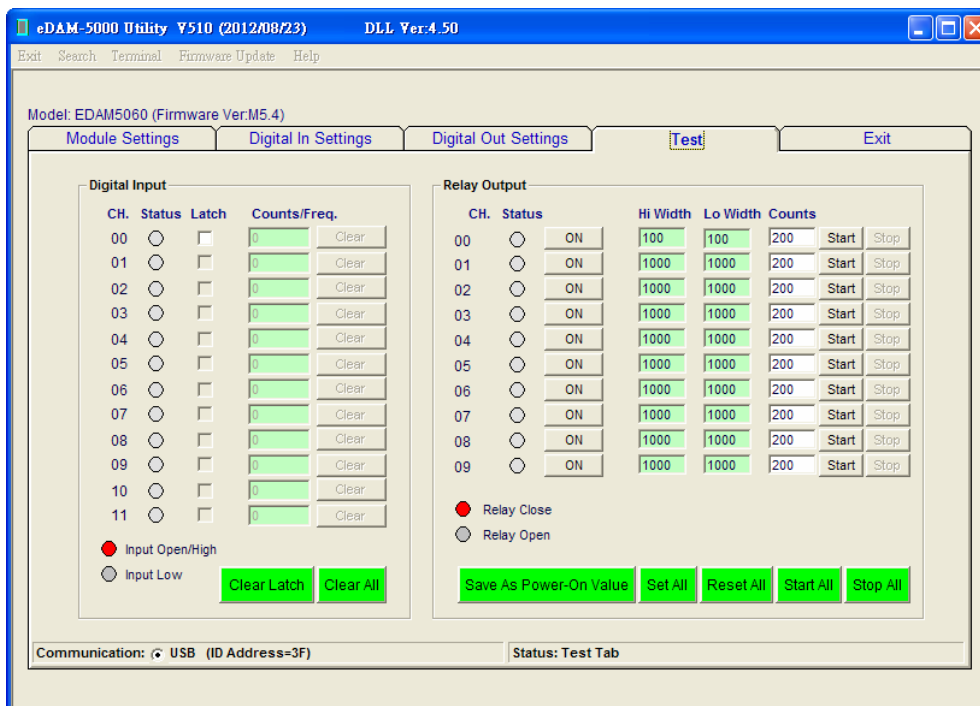

Figure - 13

- **Clear Latch button:**
Clear all DI channels latch flag
- **Clear button**
Clear single DI channel counter to zero
- **Clear All button**
Clear all DI channels counter to zero
- **ON/OFF button**
Toggle single DO channel output value
- **Counts TextBox**
Enter the DO pulse counts
- **Start button:**
Start to Generate DO pulse output
- **Stop button:**
Stop DO pulse output
- **Save as Power-on Value button:**
Set current DO value as power-on value
- **Set all button:**
Set all DO channels to active state
- **Reset all button:**
Set all DO channels to inactive state
- **Start All button:**
Start all channels to generate DO pulse output
- **Stop All button:**
Stop all channels DO pulse output

15.7 EDAM5029 Settings

15.7.1 Module settings tab

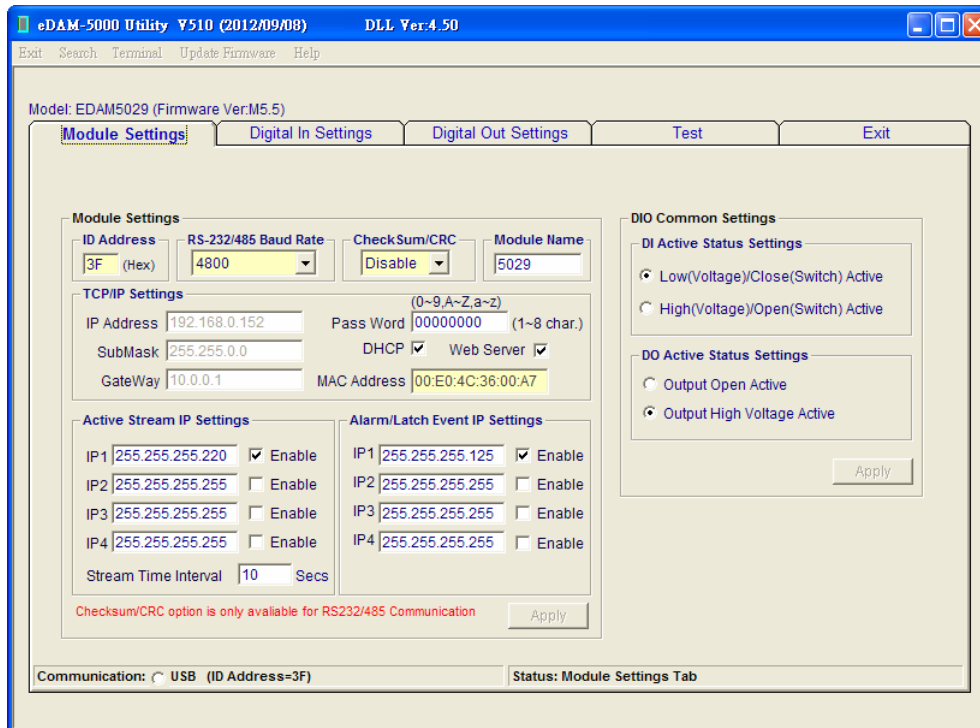

Figure - 14

- **MAC Address:**
The Ethernet address and needs no further configuration.
- **IP Address, Subnet Mask, and Default Gateway:** (default 10.0.0.1, 255.0.0.0 and 0.0.0.0)
The IP address identifies your EDAM-5000 devices on the global network. Each EDAM-5000 has same default IP address **10.0.0.1**. Therefore, *please do not initial many EDAM-5000 at the same time to avoid the Ethernet collision*. If you want to configure the EDAM-5000 in the host PC's dominating network, only the IP address and Subnet Mask will need to set (The host PC and EDAM Ethernet I/O must belong to same subnet Mask).
- **DHCP:** (default Enabled)
Allow you to get IP address from the DHCP servo without setting IP address by manual.
- **Web Server:** (default Enabled)
Allow you monitor and control I/O status on EDAM-9000 modules remotely through web browser.
- **Module ID:** (default 01)
Unique ID number of module can be set by DIP switch on the back side of module (See Help)
- **Password:** (default 00000000)
Allow you to change the password of the module (needed for Ethernet connection only)
- **Stream/Event IP:**
Set Stream /Event data Destination IP
- **Stream/Event Enable Setting:** (default all disabled)
Enable/disable Stream and Event functions
- **Stream time interval:** (default 10 sec)
Set time interval for sending stream data
- **DI active state settings:**
Set DI active state (High input active or low input active)
- **DO active state settings:**
Set DO output active state (High/open output active or low output active)

15.7.2 Digital input settings tab

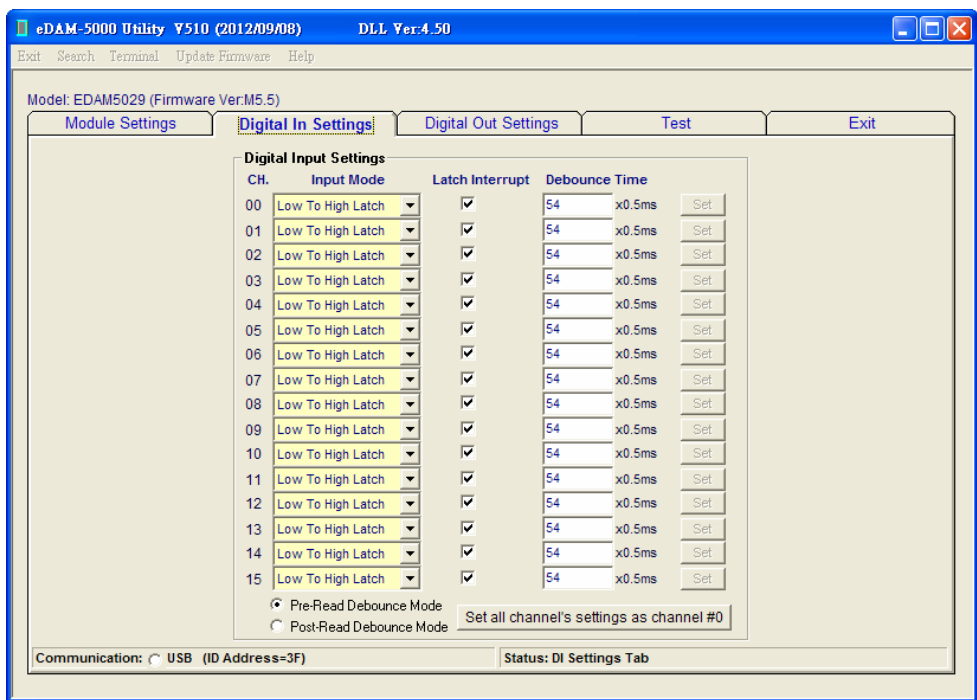

Figure - 15

- **DI channel Input Mode:**
Direct input ,counter, low to high latch, high to low latch, frequency mode
- **Latch Interrupt:**
Enable/Disable DI latch interrupt (USB connection only)
- **Debounce time:**
Set DI input debounce time (0~65535). =0 no debounce
- **Select Pre-read debounce/Post read debounce mode (see Figure - 11)**

Pre-read mode

The device read DI state immediately when DI state-changed and then delay 5000 msec to filter all other states changed in this time interval(A/B/C/D states are all ignored by device)

Post-read mode

The bounce detection is started when DI state-changed and then read final DI state after 5000 msec delay reached

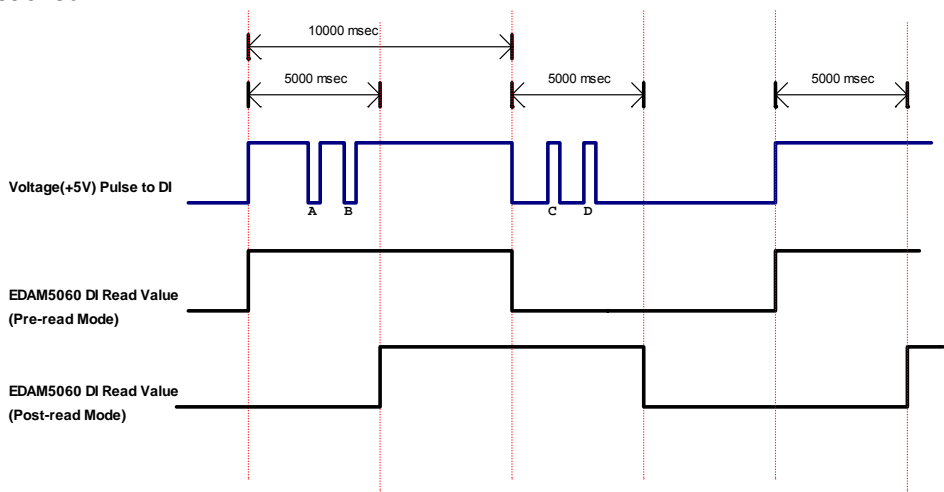

Figure - 16

- **Set all channels settings as channel 0**
Configure all channel settings as channel 0 settings

15.7.3 Digital output settings tab

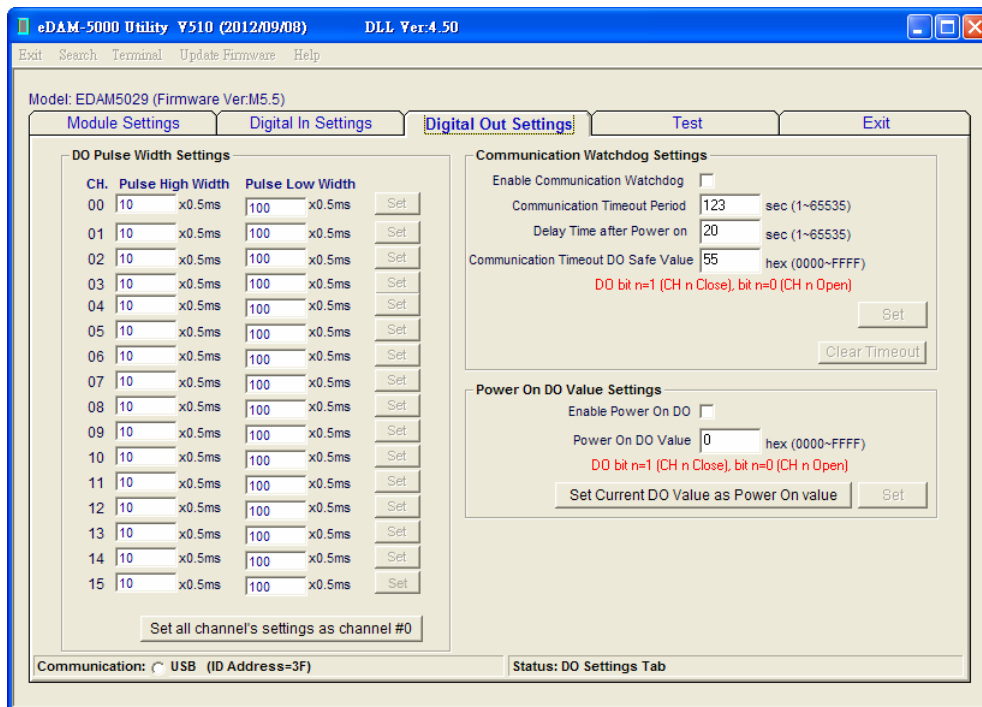

Figure - 17

- **DO pulse width:**
Set high level width and low level width for DO pulse output operation
- **Communication watchdog:**
 - **Enable/disable communication watchdog**
If there are no data received from host When communication timeout is reached, The DO will be set to specified safe value.
 - **Communication timeout period**
Set Communication timeout value
 - **Delay time after power-on**
The delay time to start communication watchdog function after module reboot
 - **Communication timeout DO safe value**
DO value when communication timeout is reached
- **Enable power-on DO:**
DO default value after module reboot
- **Power-on DO value:**
Set Power-on DO value

15.7.4 Test tab

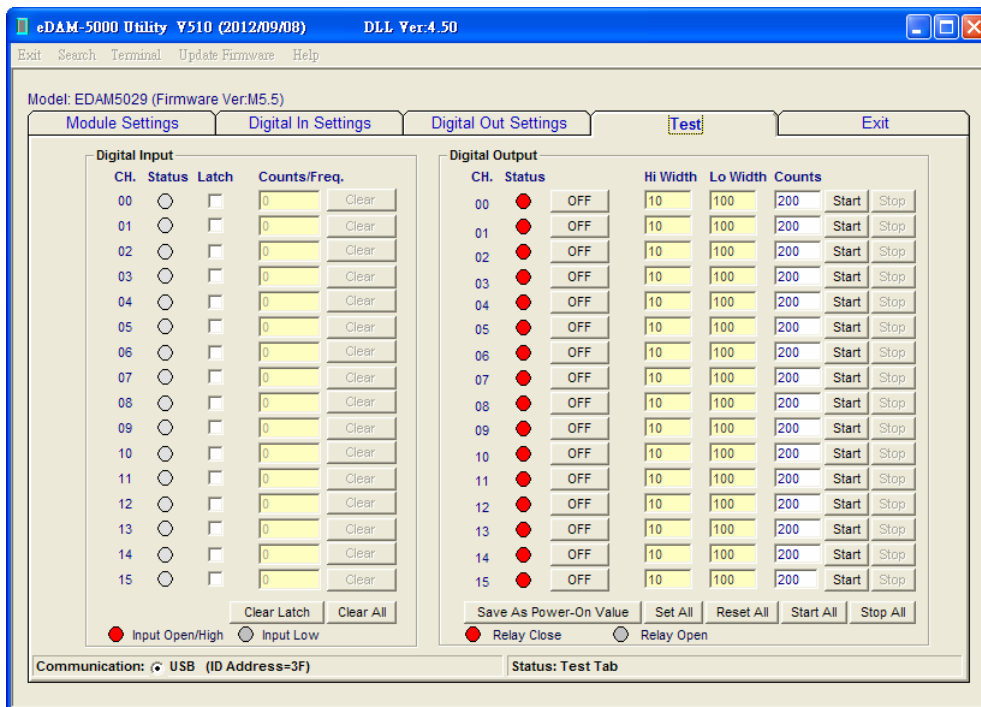

Figure - 18

- **Clear Latch button:**
Clear all DI channels latch flag
- **Clear button**
Clear single DI channel counter to zero
- **Clear All button**
Clear all DI channels counter to zero
- **ON/OFF button**
Toggle single DO channel output value
- **Counts TextBox**
Enter the DO pulse counts
- **Start button:**
Start to Generate DO pulse output
- **Stop button:**
Stop DO pulse output
- **Save as Power-on Value button:**
Set current DO value as power-on value
- **Set all button:**
Set all DO channels to active state
- **Reset all button:**
Set all DO channels to inactive state
- **Start All button:**
Start all channels to generate DO pulse output
- **Stop All button:**
Stop all channels DO pulse output

15.8 EDAM5028 Settings

15.8.1 Module settings tab

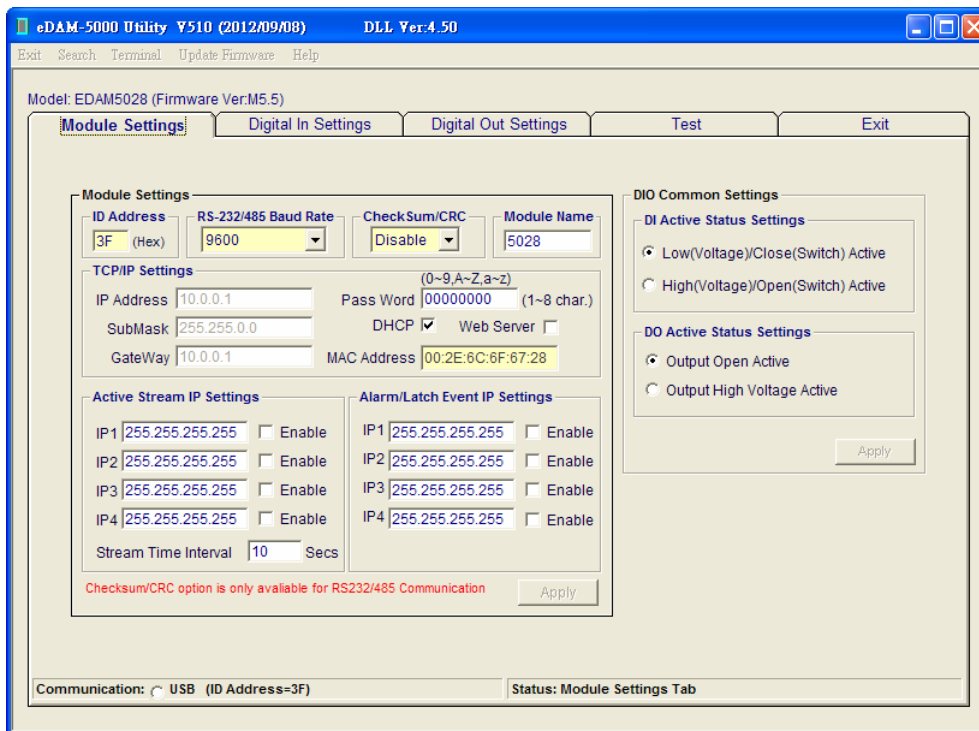

Figure - 19

- **MAC Address:**
The Ethernet address and needs no further configuration.
- **IP Address, Subnet Mask, and Default Gateway:** (default 10.0.0.1, 255.0.0.0 and 0.0.0.0)
The IP address identifies your EDAM-5000 devices on the global network. Each EDAM-5000 has same default IP address **10.0.0.1**. Therefore, *please do not initial many EDAM-5000 at the same time to avoid the Ethernet collision*. If you want to configure the EDAM-5000 in the host PC's dominating network, only the IP address and Subnet Mask will need to set (The host PC and EDAM Ethernet I/O must belong to same subnet Mask).
- **DHCP:** (default Enabled)
Allow you to get IP address from the DHCP servo without setting IP address by manual.
- **Web Server:** (default Enabled)
Allow you monitor and control I/O status on EDAM-9000 modules remotely through web browser.
- **Module ID:** (default 01)
Unique ID number of module can be set by DIP switch on the back side of module (See Help)
- **Password:** (default 00000000)
Allow you to change the password of the module (needed for Ethernet connection only)
- **Stream/Event IP:**
Set Stream /Event data Destination IP
- **Stream/Event Enable Setting:** (default all disabled)
Enable/disable Stream and Event functions
- **Stream time interval:** (default 10 sec)
Set time interval for sending stream data
- **DI active state settings:**
Set DI active state (High input active or low input active)
- **DO active state settings:**
Set DO output active state (High/open output active or low output active)

15.8.2 Digital input settings tab

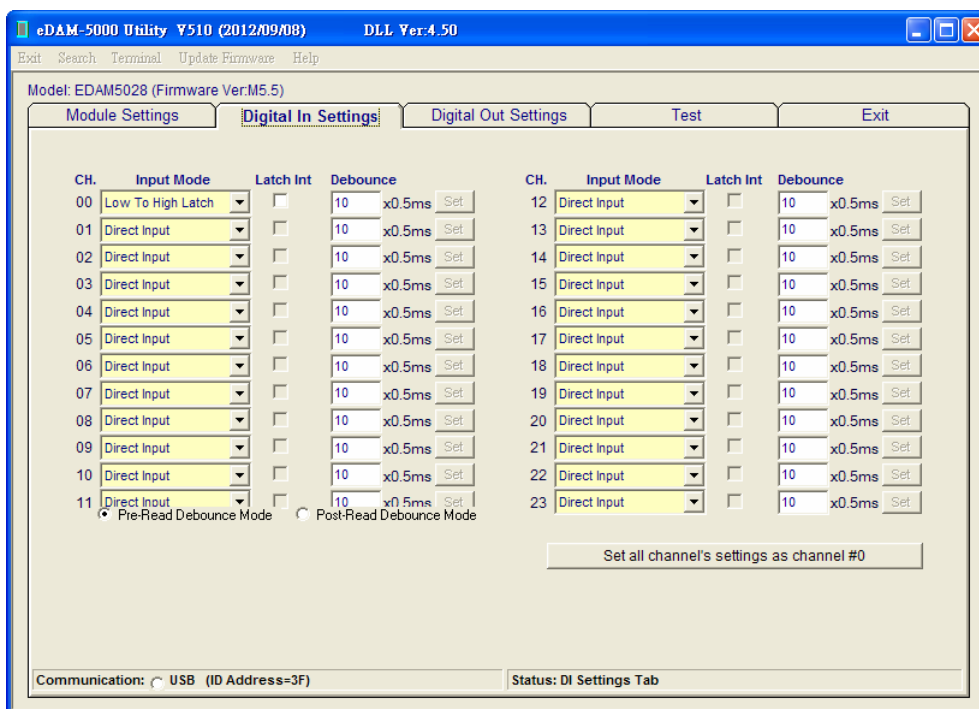

Figure - 20

- **DI channel Input Mode:**
Direct input ,counter, low to high latch, high to low latch, frequency mode
- **Latch Interrupt:**
Enable/Disable DI latch interrupt (USB connection only)
- **Debounce time:**
Set DI input debounce time (0~65535). =0 no debounce
- **Select Pre-read debounce/Post read debounce mode (see Figure - 11)**

Pre-read mode

The device read DI state immediately when DI state-changed and then delay 5000 msec to filter all other states changed in this time interval(A/B/C/D states are all ignored by device)

Post-read mode

The bounce detection is started when DI state-changed and then read final DI state after 5000 msec delay reached

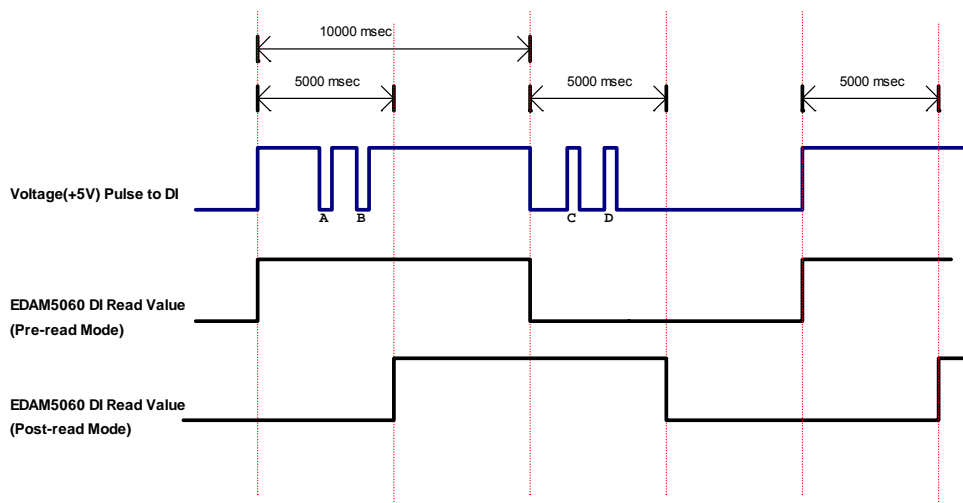

Figure - 21

- **Set all channels settings as channel 0**
Configure all channel settings as channel 0 settings

15.8.3 Digital output settings tab

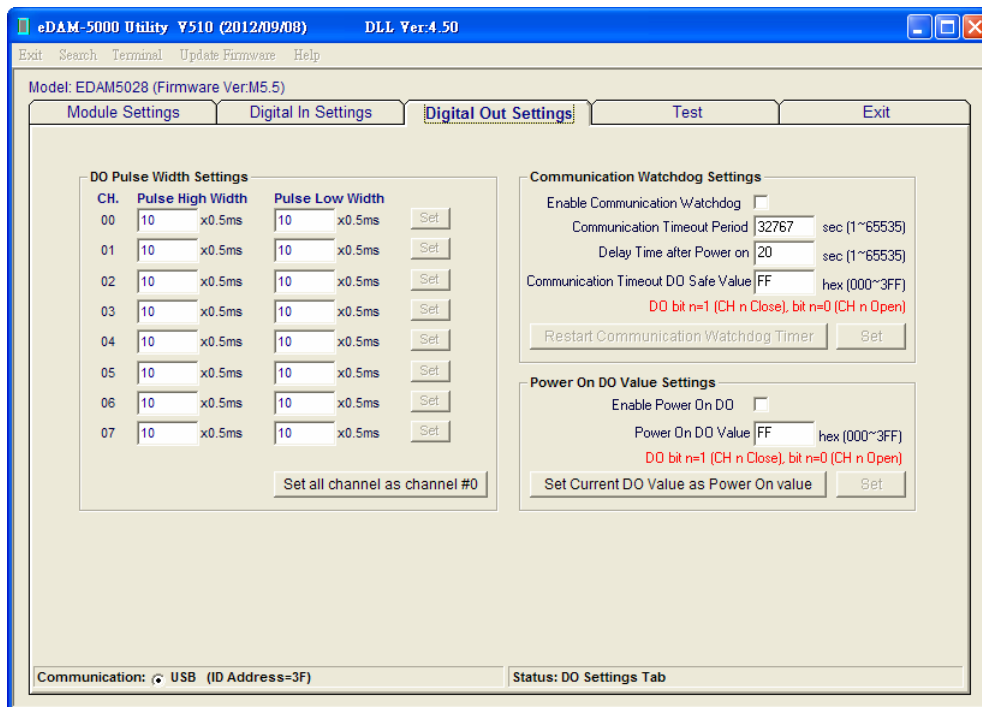

Figure - 22

- **DO pulse width:**
Set high level width and low level width for DO pulse output operation
- **Communication watchdog:**
 - **Enable/disable communication watchdog**
If there are no data received from host When communication timeout is reached, The DO will be set to specified safe value.
 - **Communication timeout period**
Set Communication timeout value
 - **Delay time after power-on**
The delay time to start communication watchdog function after module reboot
 - **Communication timeout DO safe value**
DO value when communication timeout is reached
- **Enable power-on DO:**
DO default value after module reboot
- **Power-on DO value:**
Set Power-on DO value

15.8.4 Test tab

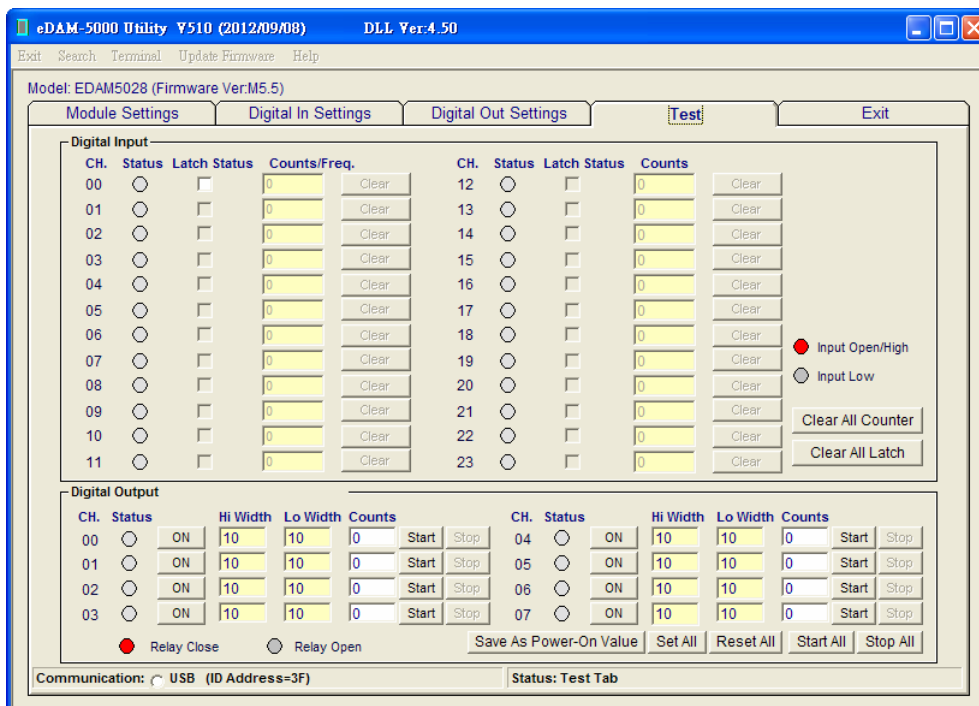

Figure - 23

- **Clear Latch button:**
Clear all DI channels latch flag
- **Clear button**
Clear single DI channel counter to zero
- **Clear All button**
Clear all DI channels counter to zero
- **ON/OFF button**
Toggle single DO channel output value
- **Counts TextBox**
Enter the DO pulse counts
- **Start button:**
Start to Generate DO pulse output
- **Stop button:**
Stop DO pulse output
- **Save as Power-on Value button:**
Set current DO value as power-on value
- **Set all button:**
Set all DO channels to active state
- **Reset all button:**
Set all DO channels to inactive state
- **Start All button:**
Start all channels to generate DO pulse output
- **Stop All button:**
Stop all channels DO pulse output

15.9 EDAM-5019 Configuration

15.9.1 Module settings tab

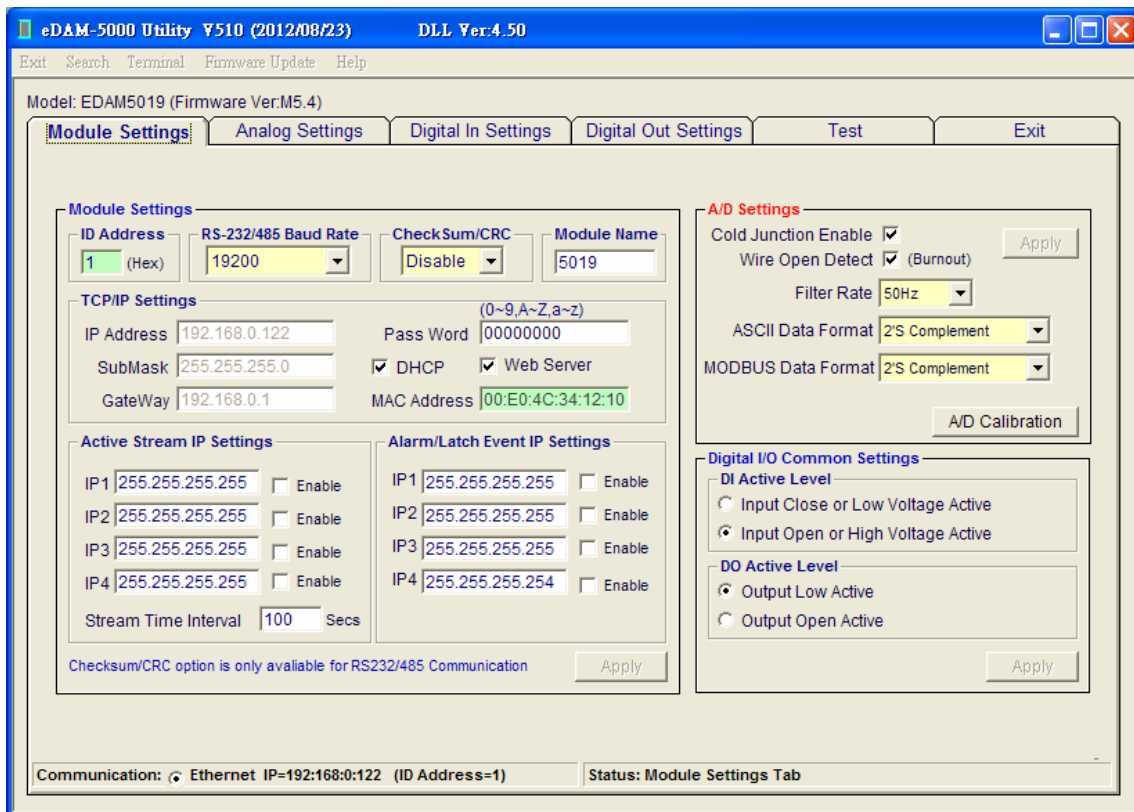

Figure - 24

- **MAC Address:**

The Ethernet address and needs no further configuration.

- **IP Address, Subnet Mask, and Default Gateway:** (default 10.0.0.1, 255.0.0.0 and 0.0.0.0)

The IP address identifies your EDAM-5000 devices on the global network. Each EDAM-5000 has same default IP address **10.0.0.1**. Therefore, *please do not initial many EDAM-5000 at the same time to avoid the Ethernet collision*. If you want to configure the EDAM-5000 in the host PC's dominating network, only the IP address and Subnet Mask will need to set (The host PC and EDAM Ethernet I/O must belong to same subnet Mask).

If you want to configure the EDAM-5000 via Internet or other network domination, you have to ask your network administrator to obtain a specific IP and Gateway addresses, and then configure each EDAM-5000 with the individual setting.

- **DHCP:** (default Enabled)

Allow you to get IP address from the DHCP servo without setting IP address by manual.

- **Web Server:** (default Enabled)

Allow you monitor and control I/O status on EDAM-9000 modules remotely through web browser.

- **Module ID:** (default 01)

Unique ID number of module can be set by DIP switch on the back side of module (See Help)

- **Password:** (default 00000000)

Allow you to change the password of the module (needed for Ethernet connection only)

- **Stream/Event IP:**

Set Stream /Event data Destination IP

- **Stream/Event Enable Setting:** (default all disabled)

Enable/disable Stream and Event functions

- **Stream time interval:** (default 10 sec)
Set time interval for sending stream data
- **DI active state settings:**
Set DI active state (High input active or low input active)
- **DO active state settings:**
Set DO output active state (High/open output active or low output active)
- **Cold junction Enable:**
Enable/disable Cold junction compensation
- **Wire open detect:**
Enable/disable input wire open detection
- **Filter rate:**
Select A/D converter filter frequency
- **ASCII Data Format**
Select ASCII data format (Engineering format or 2's complement format)
- **Modbus Data Format**
Select Modbus data format (Engineering format or 2's complement format)
- **A/D calibration button**
Calibrate EDAM5019 analog channels(Span and zero calibrations)

15.9.2 Analog settings tab

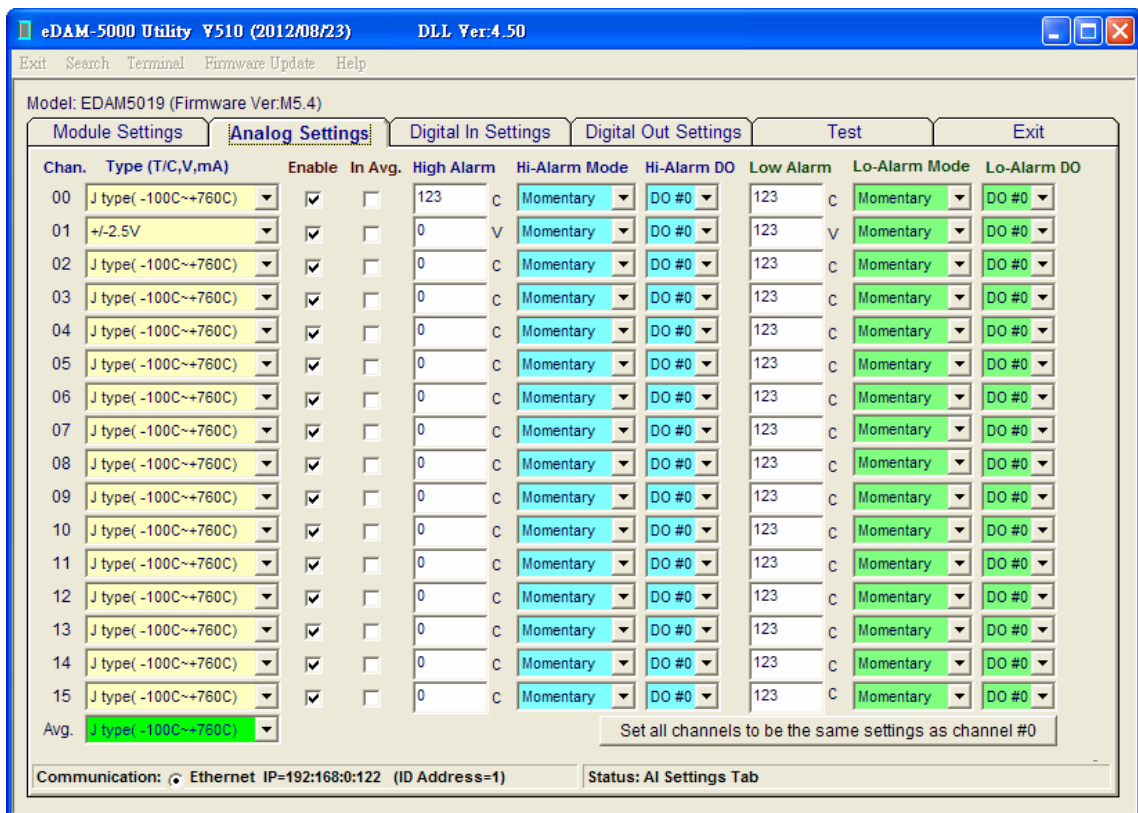

- **Type:**
Select analog input channel type
- **Enable button:**
Enable/disable single channel

- **In Avg. button:**
Enable/disable channel to be in average
- **High Alarm Textbox:**
Set AI channel high alarm value
- **Low Alarm Textbox:**
Set AI channel low alarm value
- **High Alarm mode Combobox:**
Select AI channel high alarm event mode
None =Disable alarm
Momentary =Generate Alarm event only when Channel value is greater than High Alarm value
Latch =Generate Alarm event when Channel value is greater than High Alarm value and latch alarm event until cleared by user)
- **Low Alarm mode Combobox:**
Select AI channel low alarm event mode
None =Disable alarm
Momentary =Generate Alarm event only when Channel value is less than low Alarm value
Latch =Generate Alarm event when Channel value is less than low Alarm value and latch alarm event until cleared by user)
- **Set All channels to be the same settings as channel #0 button:**
Set all AI channels to have the same settings as channel #0

15.9.3 Digital input settings tab

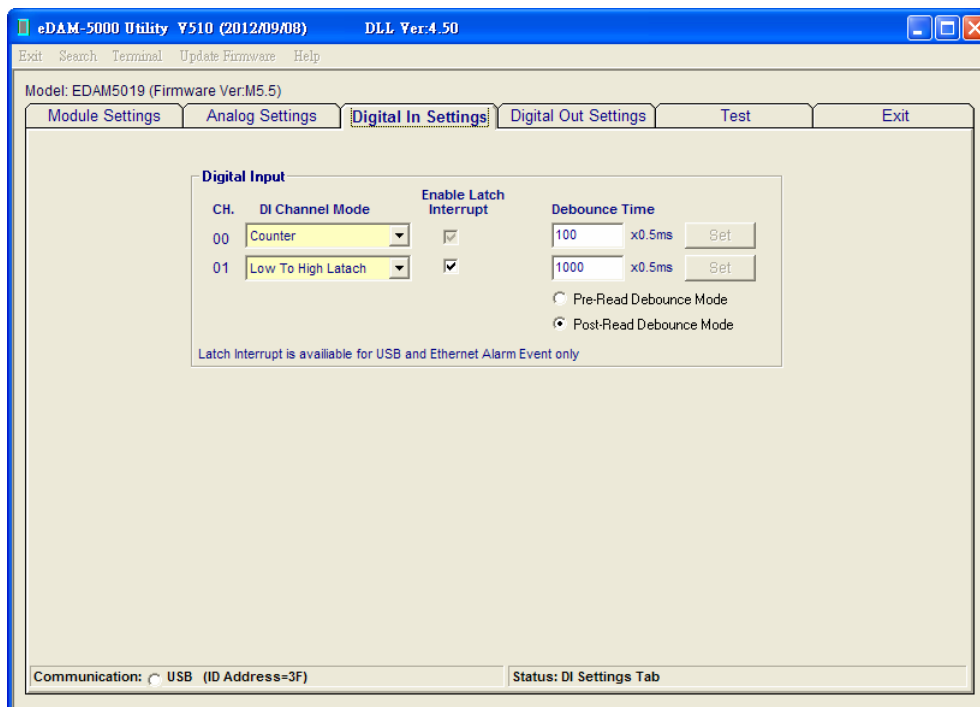

Figure - 25

- **DI channel Input Mode:**
Direct input ,counter, low to high latch, high to low latch, frequency mode
- **Latch Interrupt:**
Enable/Disable DI latch interrupt (USB connection only)
- **Debounce time:**
Set DI input debounce time (0~65535). =0 no debounce

- **Select Pre-read debounce/Post read debounce mode (see Figure - 11)**

Pre-read mode

The device read DI state immediately when DI state-changed and then delay 5000 msec to filter all other states changed in this time interval(A/B/C/D states are all ignored by device)

Post-read mode

The bounce detection is started when DI state-changed and then read final DI state after 5000 msec delay reached

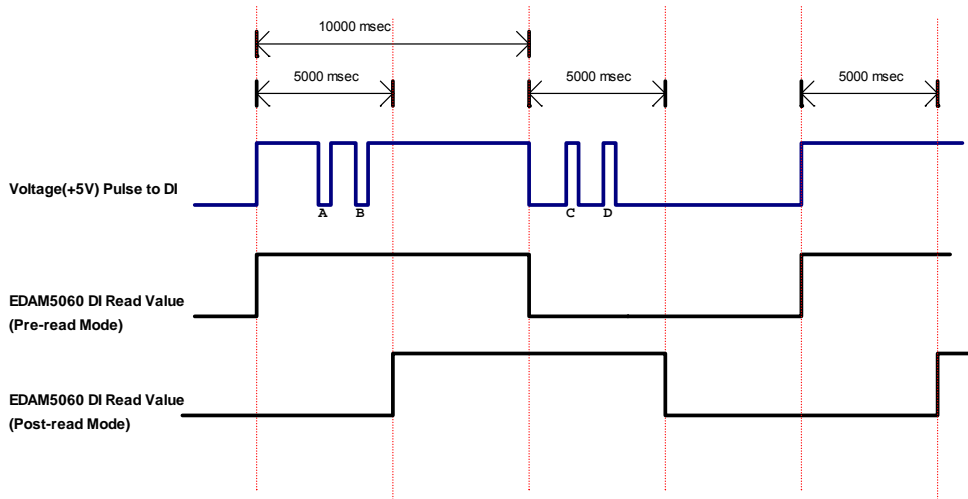

Figure - 26

- **Set all channels settings as channel 0**
Configure all channel settings as channel 0 settings

15.9.4 Digital output settings tab

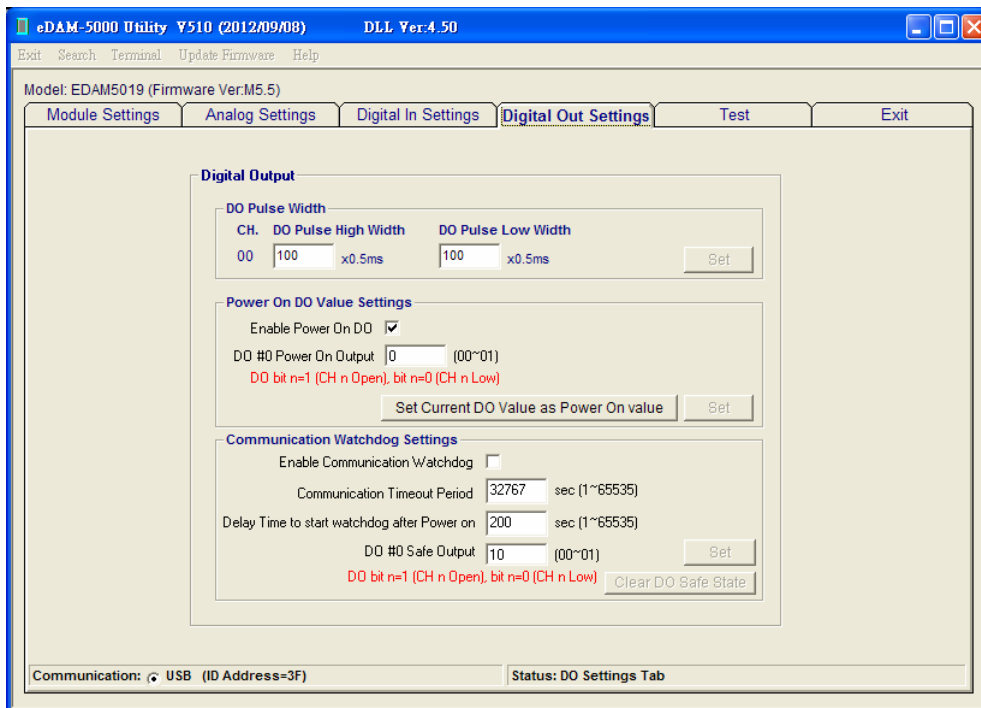

Figure - 27

- **DO pulse width:**
Set high level width and low level width for DO pulse output operation

- **Communication watchdog:**
 - **Enable/disable communication watchdog**
If there are no data received from host When communication timeout is reached, The DO will be set to specified safe value.
 - **Communication timeout period**
Set Communication timeout value
 - **Delay time after power-on**
The delay time to start communication watchdog function after module reboot
 - **Communication timeout DO safe value**
DO value when communication timeout is reached
- **Enable power-on DO:**
DO default value after module reboot
- **Power-on DO value:**
Set Power-on DO value

15.9.5 Test tab

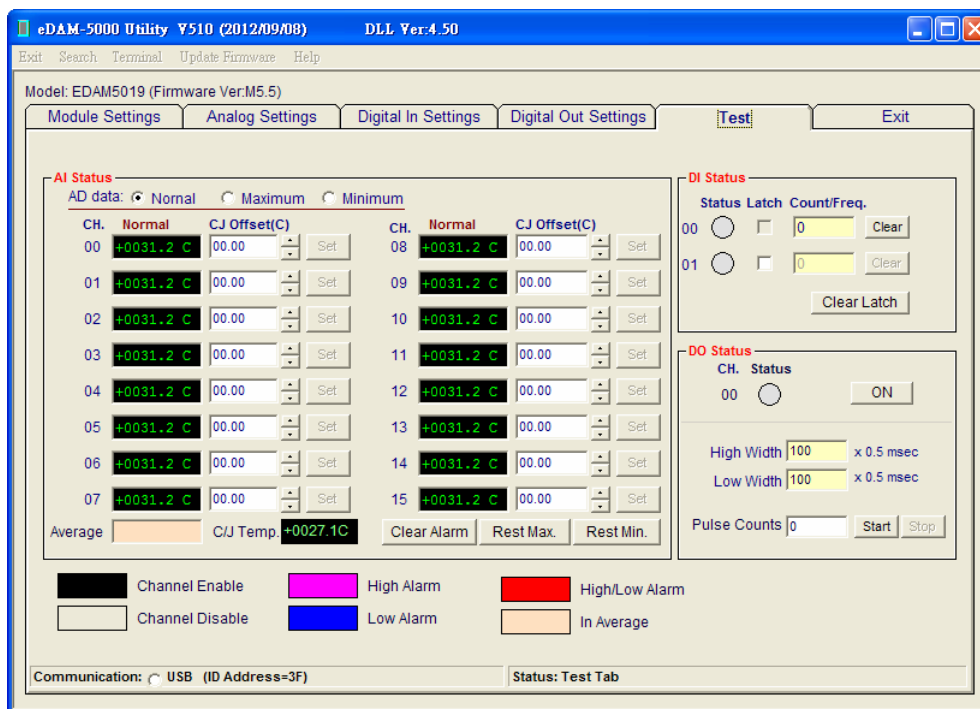

Figure - 28

- **Clear button**
Clear single DI channel counter to zero
- **ON/OFF button**
Toggle single DO channel output value
- **Counts TextBox**
Enter the DO pulse counts
- **Start button:**
Start to Generate DO pulse output
- **Stop button:**
Stop DO pulse output

- **Clear Alarm button:**
Set all analog channel alarm events
- **Reset Max. button:**
Reset all analog Maximum value
- **Reset Min. button:**
Reset all analog Minimum value

15.10 EDAM-5017 Configuration

15.10.1 Module settings tab

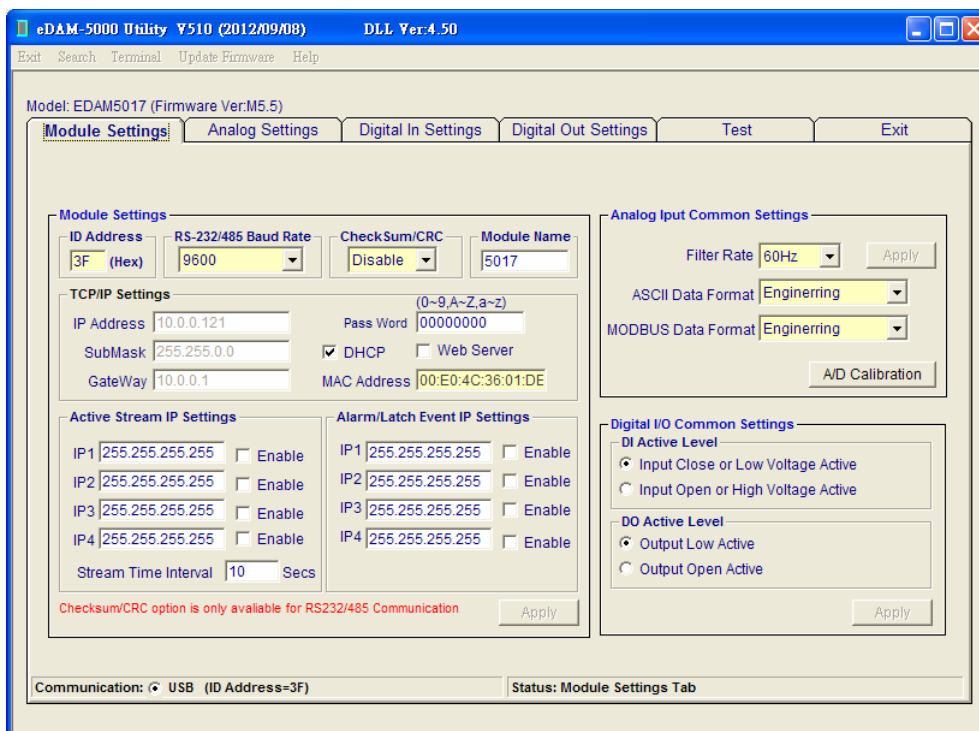

Figure - 29

- **MAC Address:**

The Ethernet address and needs no further configuration.

- **IP Address, Subnet Mask, and Default Gateway:** (default 10.0.0.1, 255.0.0.0 and 0.0.0.0)

The IP address identifies your EDAM-5000 devices on the global network. Each EDAM-5000 has same default IP address **10.0.0.1**. Therefore, *please do not initial many EDAM-5000 at the same time to avoid the Ethernet collision*. If you want to configure the EDAM-5000 in the host PC's dominating network, only the IP address and Subnet Mask will need to set (The host PC and EDAM Ethernet I/O must belong to same subnet Mask).

If you want to configure the EDAM-5000 via Internet or other network domination, you have to ask your network administrator to obtain a specific IP and Gateway addresses, and then configure each EDAM-5000 with the individual setting.

- **DHCP:** (default Enabled)

Allow you to get IP address from the DHCP servo without setting IP address by manual.

- **Web Server:** (default Enabled)

Allow you monitor and control I/O status on EDAM-9000 modules remotely through web browser.

- **Module ID:** (default 01)

Unique ID number of module can be set by DIP switch on the back side of module (See Help)

- **Password:** (default 00000000)

Allow you to change the password of the module (needed for Ethernet connection only)

- **Stream/Event IP:**

Set Stream /Event data Destination IP

- **Stream/Event Enable Setting:** (default all disabled)

Enable/disable Stream and Event functions

- **Stream time interval:** (default 10 sec)
Set time interval for sending stream data
- **DI active state settings:**
Set DI active state (High input active or low input active)
- **DO active state settings:**
Set DO output active state (High/open output active or low output active)
- **Filter rate:**
Select A/D converter filter frequency
- **ASCII Data Format**
Select ASCII data format (Engineering format or 2's complement format)
- **Modbus Data Format**
Select Modbus data format (Engineering format or 2's complement format)
- **A/D calibration button**
Calibrate EDAM5019 analog channels(Span and zero calibrations)

15.10.2 Analog settings tab

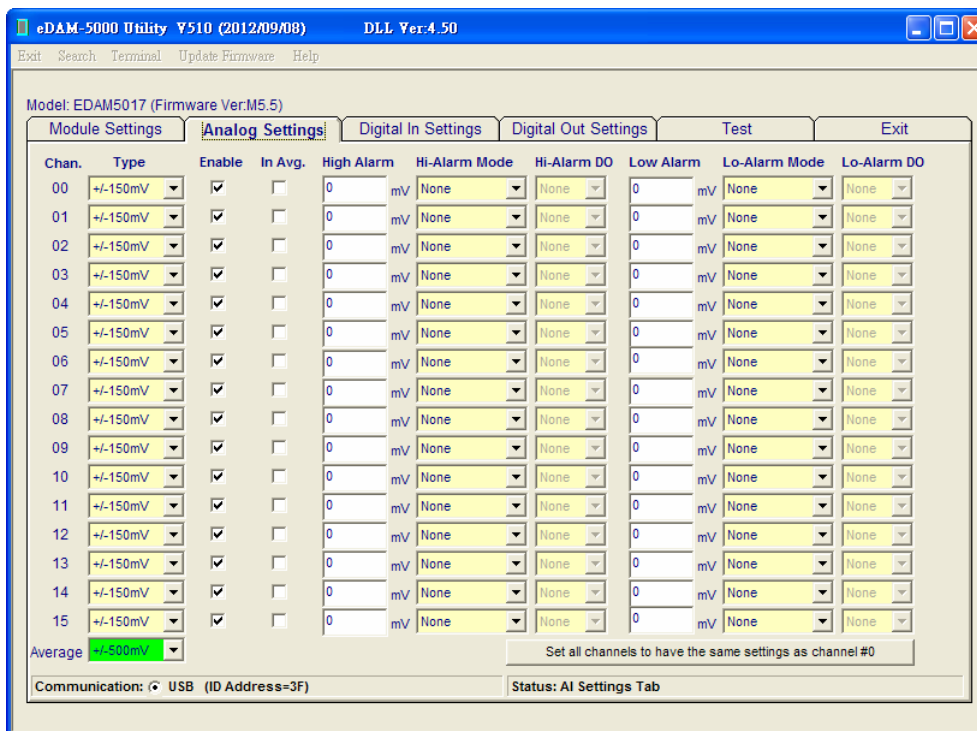

- **Type:**
Select analog input channel type
- **Enable button:**
Enable/disable single channel
- **In Avg. button:**
Enable/disable channel to be in average
- **High Alarm Textbox:**
Set AI channel high alarm value
- **Low Alarm Textbox:**
Set AI channel low alarm value

- High Alarm mode Combobox:
 Select AI channel high alarm event mode
None =Disable alarm
Momentary =Generate Alarm event only when Channel value is greater than High Alarm value
Latch =Generate Alarm event when Channel value is greater than High Alarm value and latch alarm event until cleared by user)
- Low Alarm mode Combobox:
 Select AI channel low alarm event mode
None =Disable alarm
Momentary =Generate Alarm event only when Channel value is less than low Alarm value
Latch =Generate Alarm event when Channel value is less than low Alarm value and latch alarm event until cleared by user)
- High Alarm DO Combobox:
 Select DO output channel when high alarm event occurred
None =No DO output
DO 0 =DO 0 output
- Low Alarm DO Combobox:
 Select DO output channel when low alarm event occurred
None =No DO output
DO 0 =DO 0 output
- **Set All channels to be the same settings as channel #0 button:**
 Set all AI channels to have the same settings as channel #0

15.10.3 Digital input settings tab

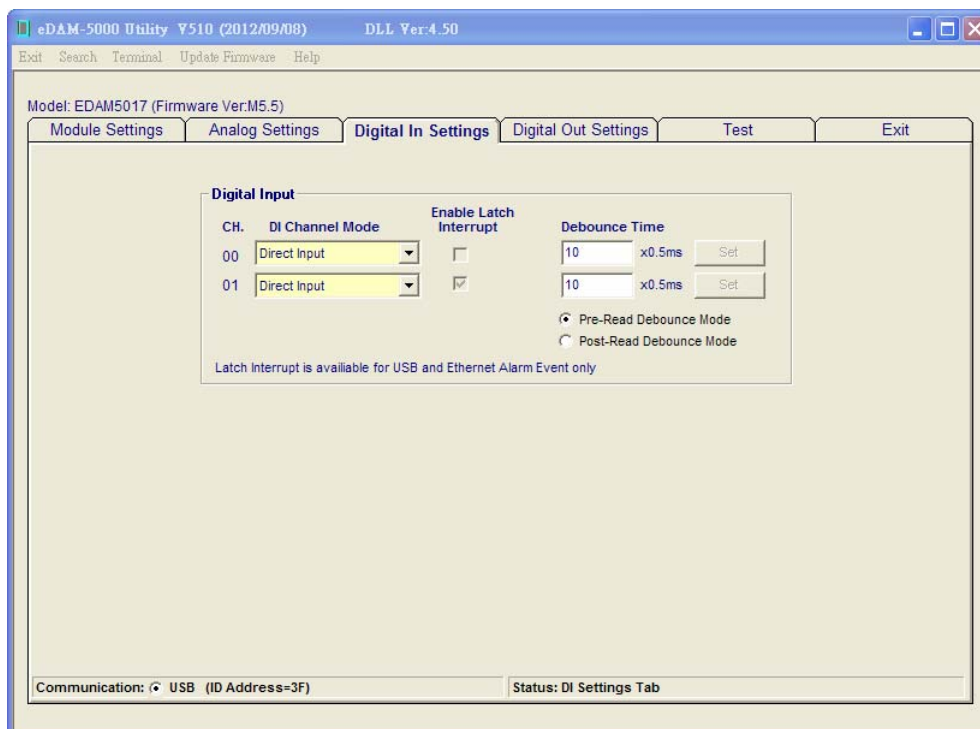

Figure - 30

- **DI channel Input Mode:**
 Direct input ,counter, low to high latch, high to low latch, frequency mode
- **Latch Interrupt:**
 Enable/Disable DI latch interrupt (USB connection only)

- **Debounce time:**
Set DI input debounce time (0~65535). =0 no debounce
- **Select Pre-read debounce/Post read debounce mode (see Figure - 11)**

Pre-read mode

The device read DI state immediately when DI state-changed and then delay 5000 msec to filter all other states changed in this time interval(A/B/C/D states are all ignored by device)

Post-read mode

The bounce detection is started when DI state-changed and then read final DI state after 5000 msec delay reached

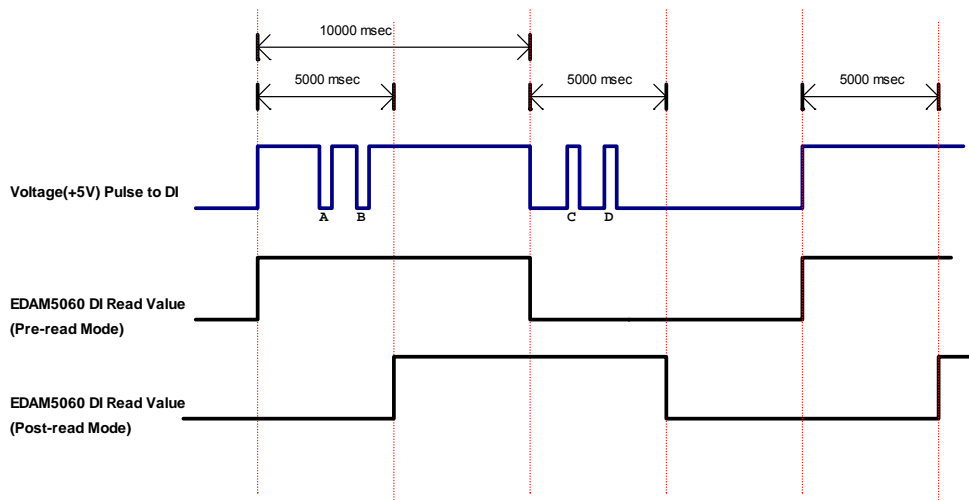

Figure - 31

- **Set all channels settings as channel 0**
Configure all channel settings as channel 0 settings

15.10.4 Digital output settings tab

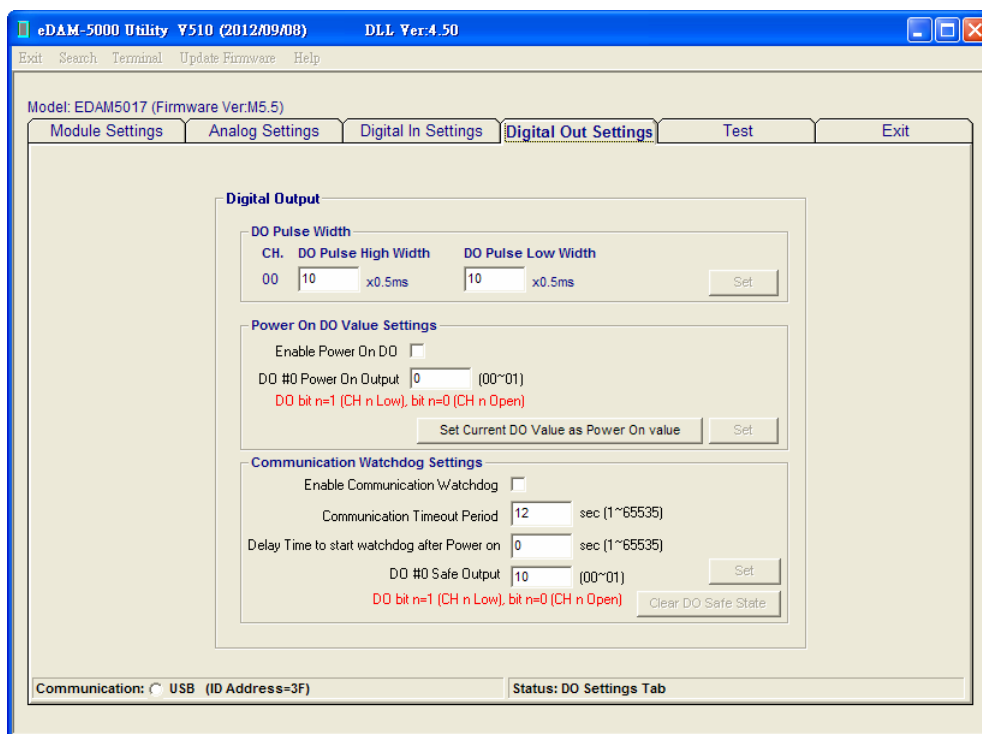

Figure - 32

- **DO pulse width:**
Set high level width and low level width for DO pulse output operation
- **Communication watchdog:**
 - **Enable/disable communication watchdog**
If there are no data received from host When communication timeout is reached, The DO will be set to specified safe value.
 - **Communication timeout period**
Set Communication timeout value
 - **Delay time after power-on**
The delay time to start communication watchdog function after module reboot
 - **Communication timeout DO safe value**
DO value when communication timeout is reached
- **Enable power-on DO:**
DO default value after module reboot
- **Power-on DO value:**
Set Power-on DO value

15.10.5 Test tab

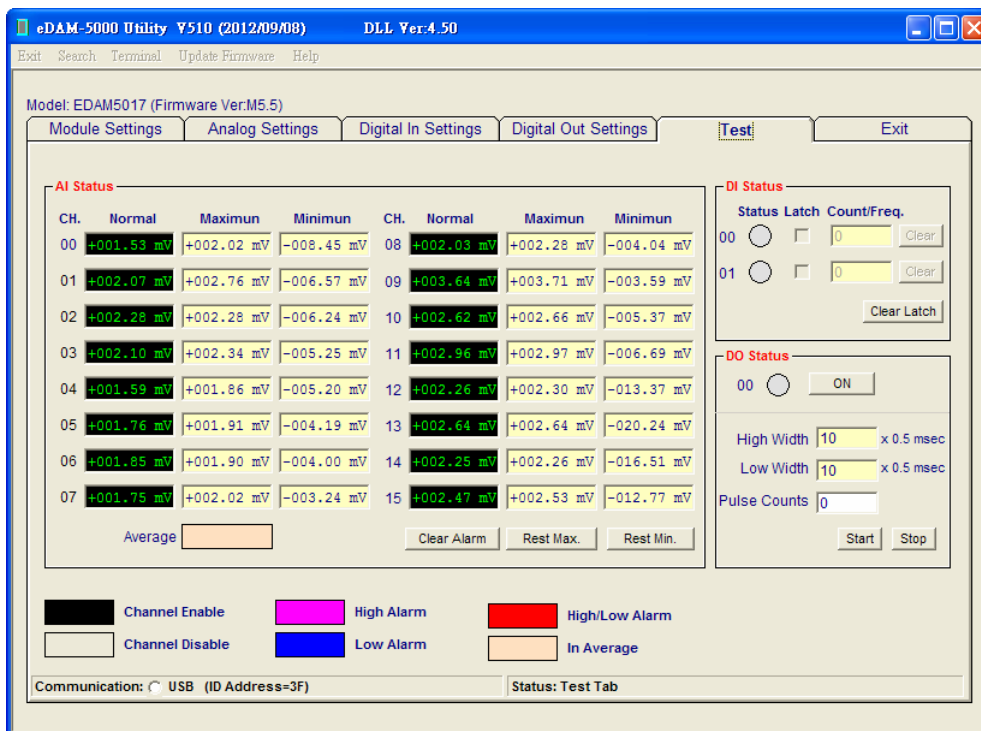

Figure - 33

- **Clear button**
Clear single DI channel counter to zero
- **ON/OFF button**
Toggle single DO channel output value
- **Counts TextBox**
Enter the DO pulse counts
- **Start button:**
Start to Generate DO pulse output

- **Stop button:**
Stop DO pulse output
- **Clear Alarm button:**
Set all analog channel alarm events
- **Reset Max. button:**
Reset all analog Maximum value
- **Reset Min. button:**
Reset all analog Minimum value

15.11 EDAM-5015 Configuration

15.11.1 Module settings tab

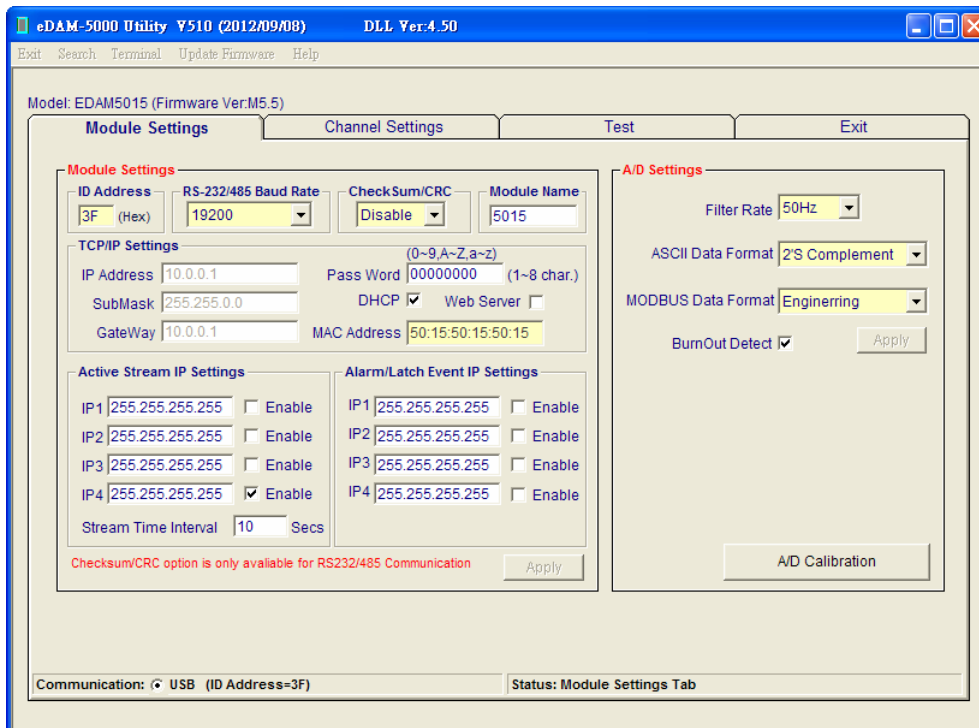
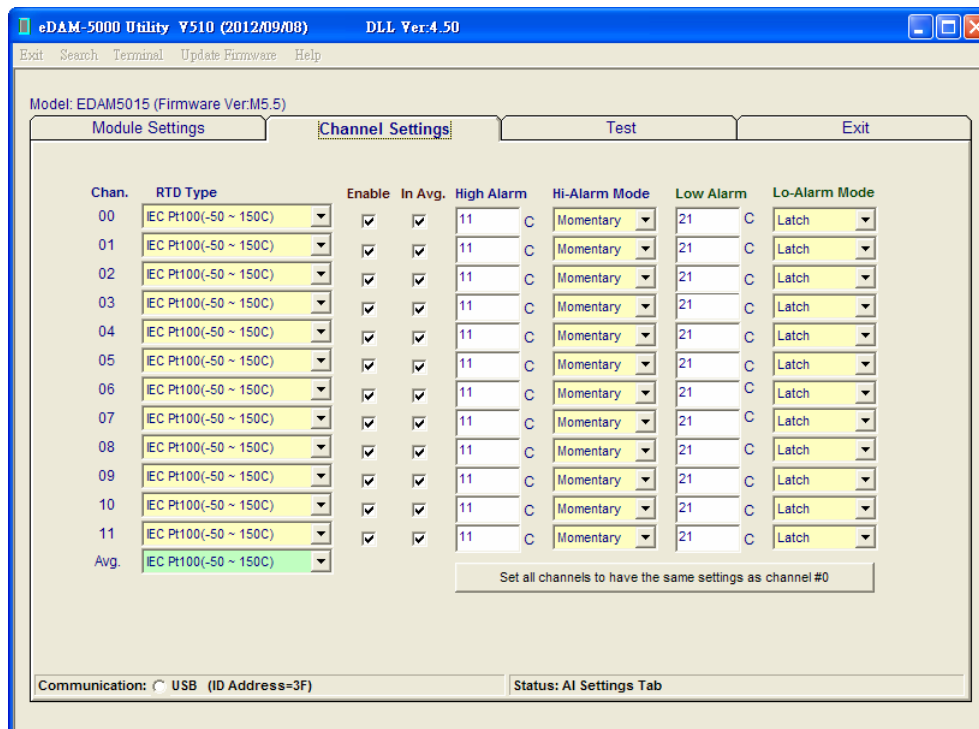

Figure - 34

- **MAC Address:**
The Ethernet address and needs no further configuration.
- **IP Address, Subnet Mask, and Default Gateway:** (default 10.0.0.1, 255.0.0.0 and 0.0.0.0)
The IP address identifies your EDAM-5000 devices on the global network. Each EDAM-5000 has same default IP address **10.0.0.1**. Therefore, *please do not initial many EDAM-5000 at the same time to avoid the Ethernet collision*. If you want to configure the EDAM-5000 in the host PC's dominating network, only the IP address and Subnet Mask will need to set (The host PC and EDAM Ethernet I/O must belong to same subnet Mask).
If you want to configure the EDAM-5000 via Internet or other network domination, you have to ask your network administrator to obtain a specific IP and Gateway addresses, and then configure each EDAM-5000 with the individual setting.
- **DHCP:** (default Enabled)
Allow you to get IP address from the DHCP servo without setting IP address by manual.
- **Web Server:** (default Enabled)
Allow you monitor and control I/O status on EDAM-9000 modules remotely through web browser.
- **Module ID:** (default 01)
Unique ID number of module can be set by DIP switch on the back side of module (See Help)
- **Password:** (default 00000000)
Allow you to change the password of the module (needed for Ethernet connection only)
- **Stream/Event IP:**
Set Stream /Event data Destination IP
- **Stream/Event Enable Setting:** (default all disabled)
Enable/disable Stream and Event functions

- **Stream time interval:** (default 10 sec)
Set time interval for sending stream data
- **DI active state settings:**
Set DI active state (High input active or low input active)
- **DO active state settings:**
Set DO output active state (High/open output active or low output active)
- **Burn out detect:**
Enable/disable input wire open detection
- **Filter rate:**
Select A/D converter filter frequency
- **ASCII Data Format**
Select ASCII data format (Engineering format or 2's complement format)
- **Modbus Data Format**
Select Modbus data format (Engineering format or 2's complement format)
- **A/D calibration button**
Calibrate EDAM5019 analog channels(Span and zero calibrations)

15.11.2 Channel settings tab



- **RTD Type:**
Select analog input channel type
- **Enable button:**
Enable/disable single channel
- **In Avg. button:**
Enable/disable channel to be in average
- **High Alarm Textbox:**
Set AI channel high alarm value

- **Low Alarm Textbox:**
Set AI channel low alarm value
- **High Alarm mode Combobox:**
Select AI channel high alarm event mode
None =Disable alarm
Momentary =Generate Alarm event only when Channel value is greater than High Alarm value
Latch =Generate Alarm event when Channel value is greater than High Alarm value and latch alarm event until cleared by user)
- **Low Alarm mode Combobox:**
Select AI channel high alarm event mode
None =Disable alarm
Momentary =Generate Alarm event only when Channel value is less than low Alarm value
Latch =Generate Alarm event when Channel value is less than low Alarm value and latch alarm event until cleared by user)

15.11.3 Test tab

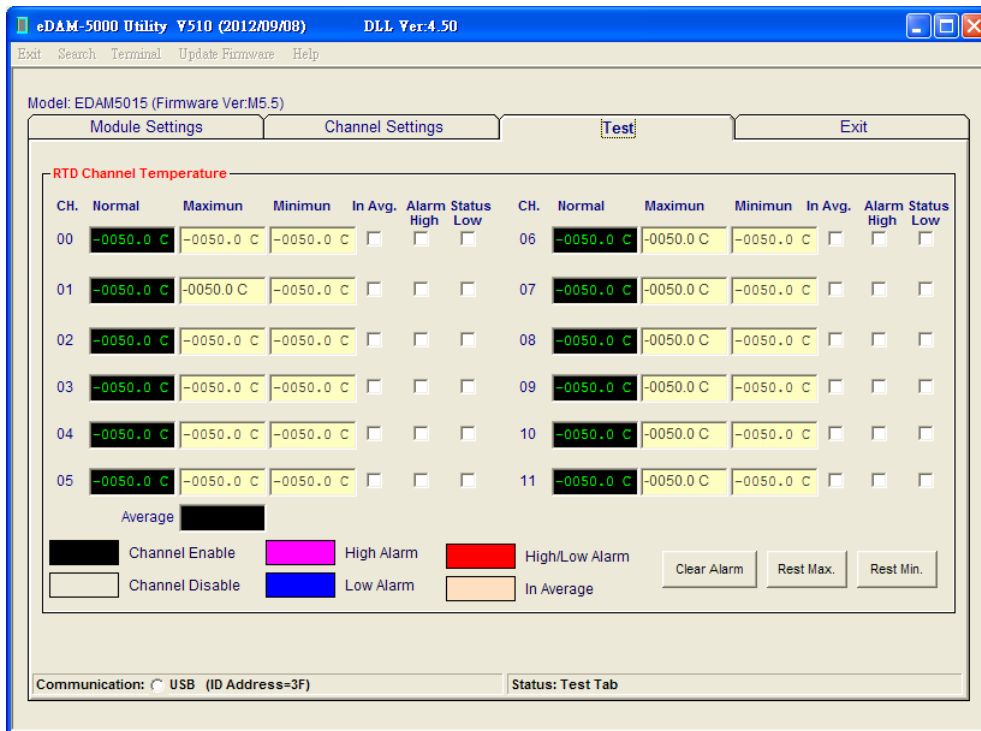

Figure - 35

- **Clear Alarm button:**
Set all analog channel alarm events
- **Reset Max. button:**
Reset all analog Maximum value
- **Reset Min. button:**
Reset all analog Minimum value

Chapter 16 Firmware Update

The EDAM-5000 utility provides on-board firmware update tool that can help you to update firmware through USB interface quickly.

The following steps show you how to update firmware

1. Set Module ID address to 3FH (A0,A1,A2, A3,A4,A5 to "ON" position)

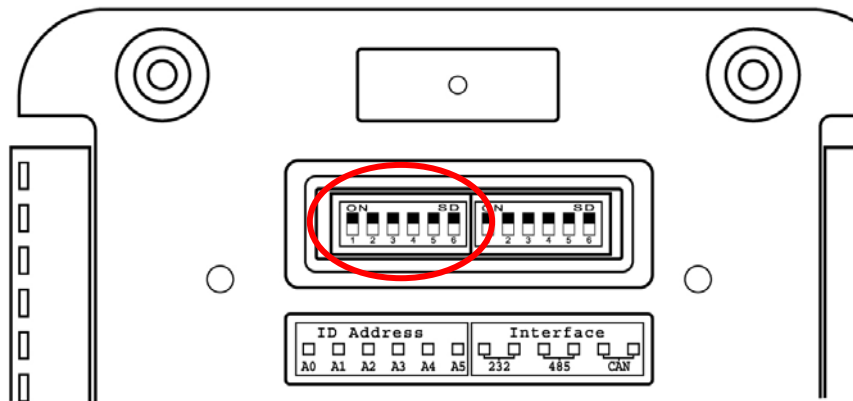

Figure -1

Where

- A0=bit 0 of ID address
- A1=bit 1 of ID address
- A2=bit 2 of ID address
- A3=bit 3 of ID address
- A4=bit 4 of ID address
- A5=bit 5 of ID address

2. Connect EDAM module to USB hub

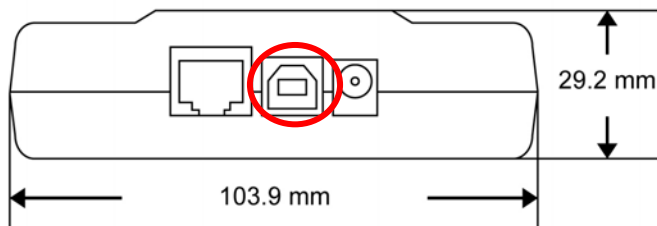

Figure -2

3. Executes provided EDAM-5000 utility called "E5KUtility.exe" (see Figure -3)

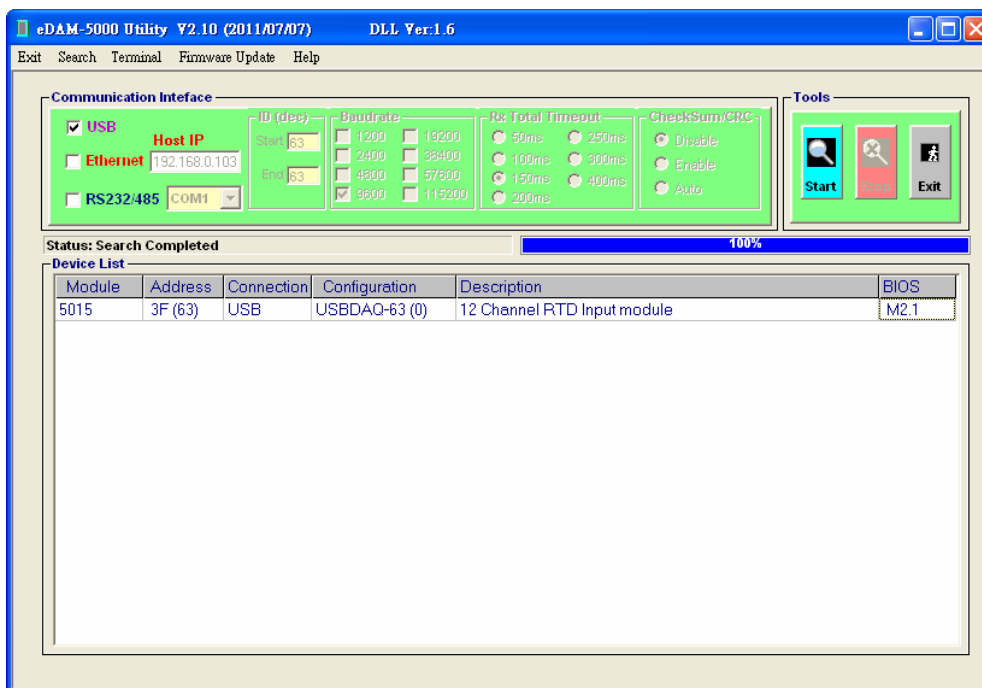

Figure -3

4. Click "Firmware Update" in the menu bar (see Figure -4)

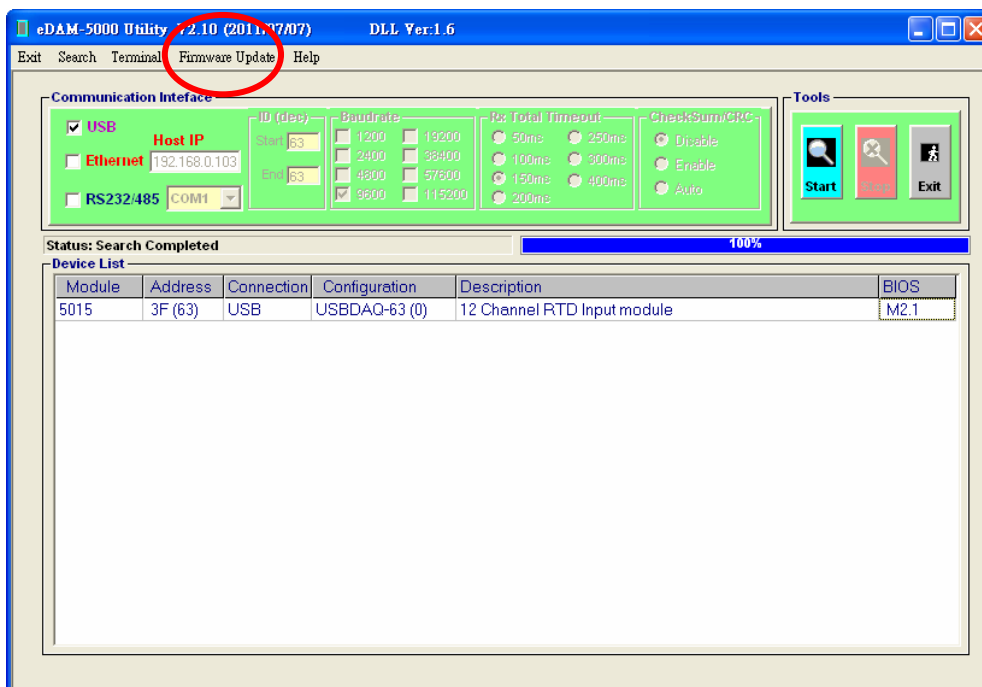

Figure -4

5. Click "Load File" button to load firmware file (see Figure -5)

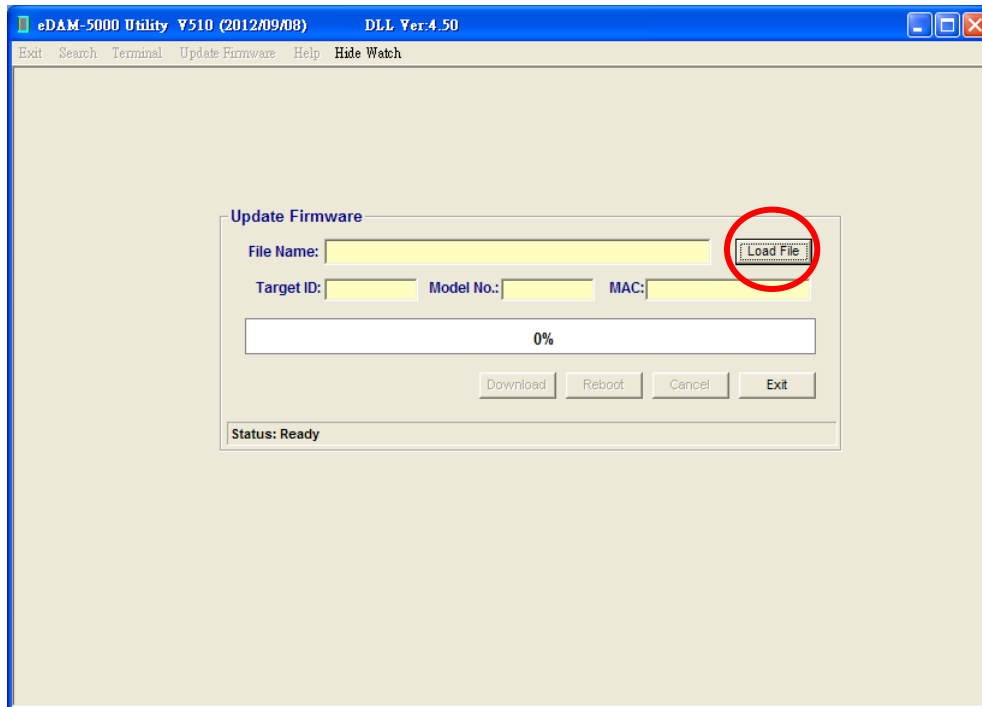

Figure -5

6. Select the firmware file your are going to update (see Figure -6)

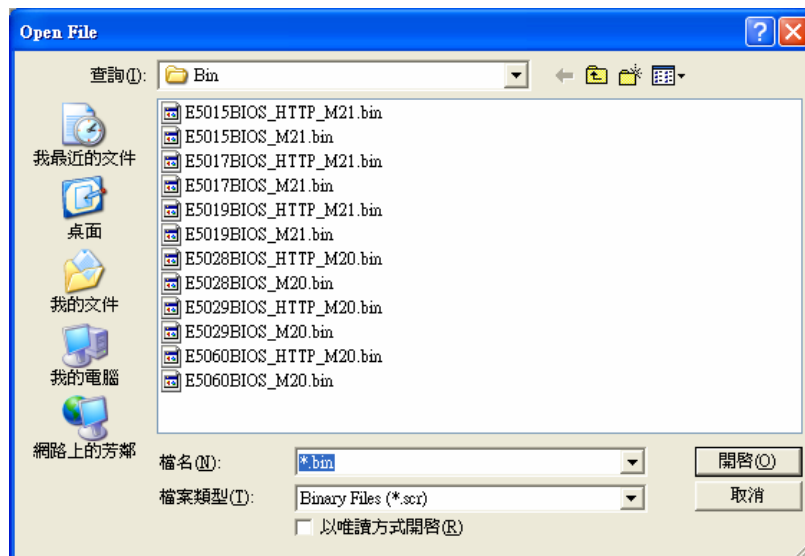

Figure -6

7. Click "Download" button to start to update firmware (see Figure -7)

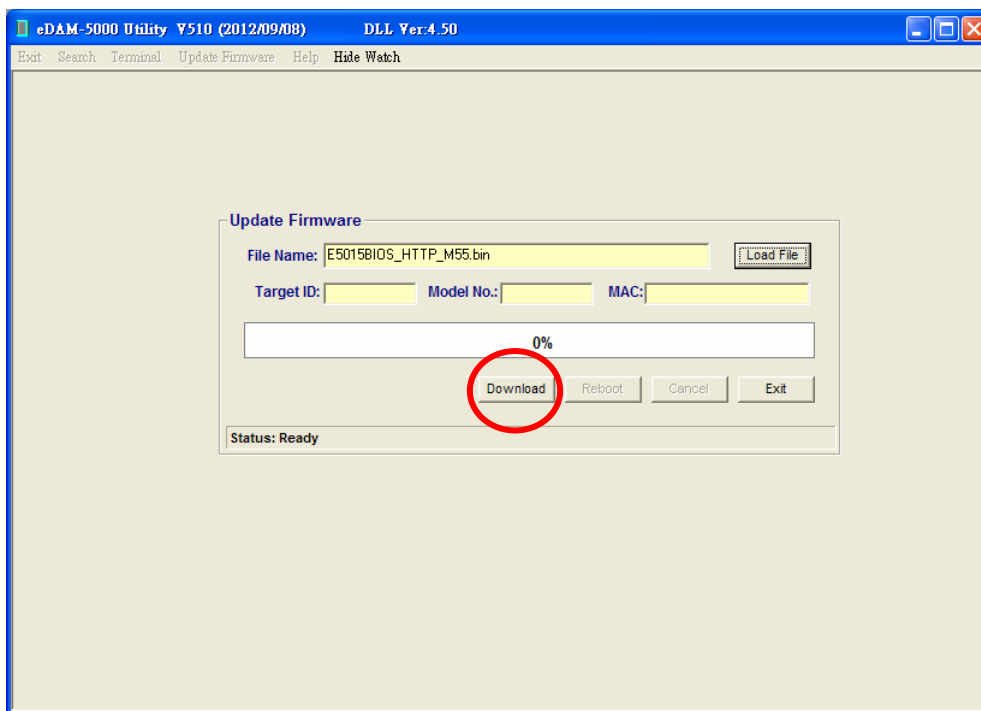

Figure -7

8. The Utility is searching module. Power-off /on the module or press "Reset button" at the down side of the module to **reboot** the module. (see Figure -8)

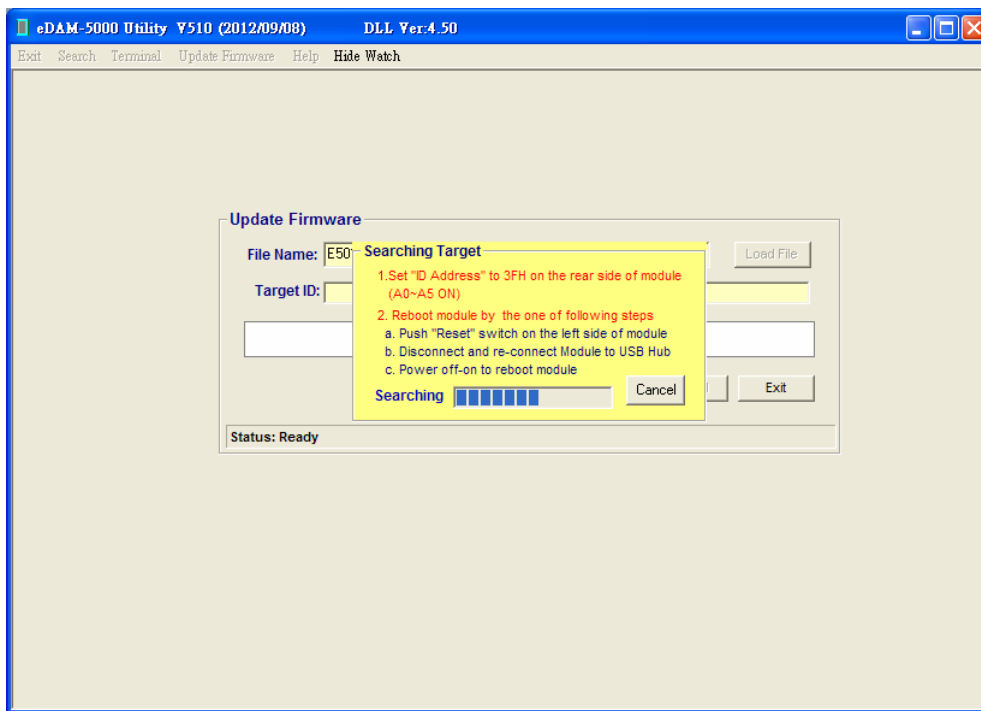

Figure -8

9. If module found. The "Target ready" window pop up (see Figure -9) .Click "OK" button to start

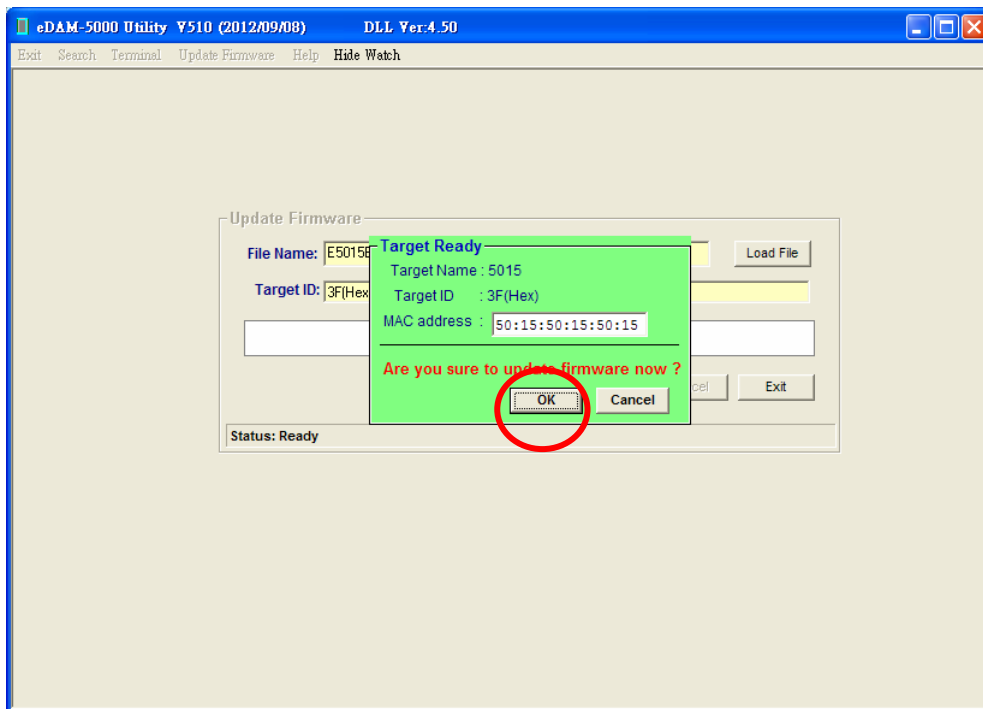

Figure -9

10. The progress bar shows the progress of updating firmware(see Figure -10)

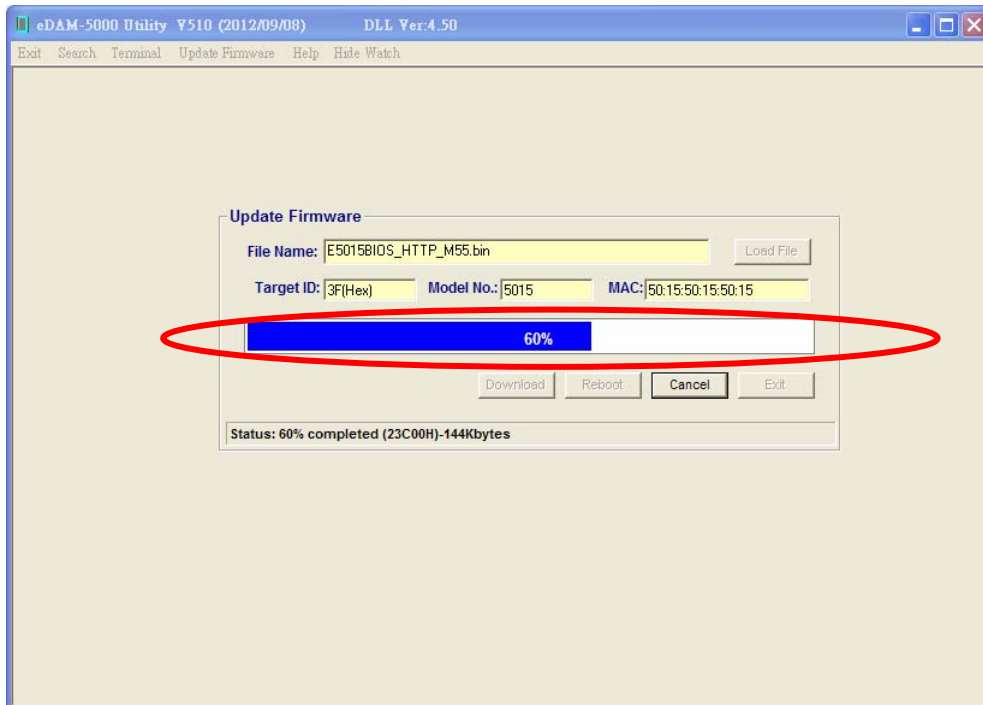
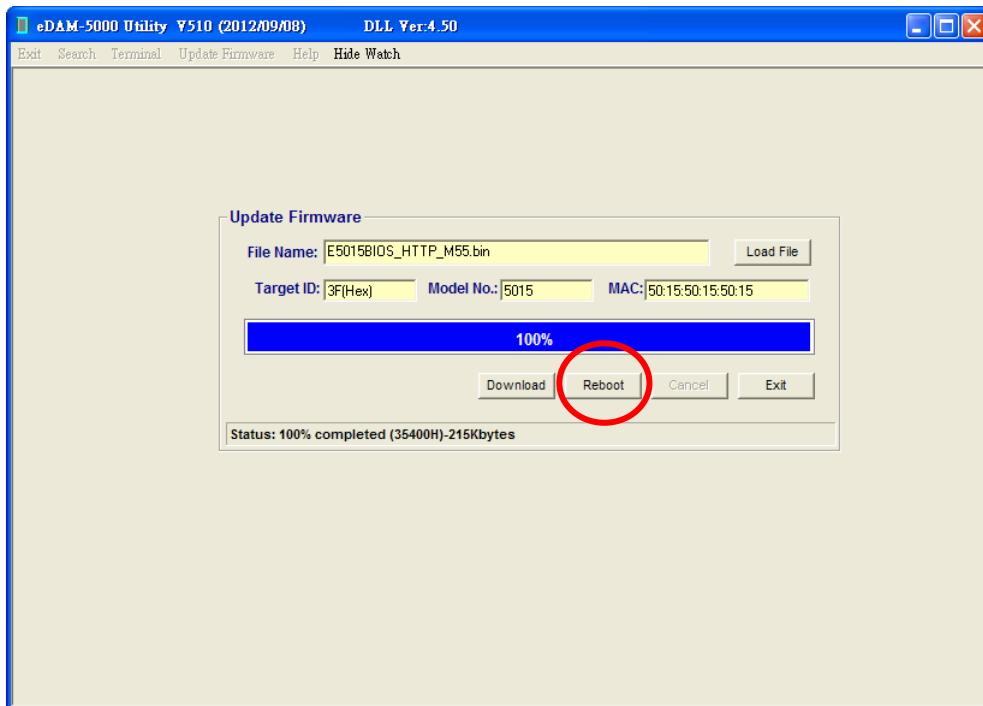

Figure -10

11. Click "Reboot" button to reboot the module



Chapter 17 Reload Default Settings

All EDAM-5xxx modules provide a way to reload the default settings (see 3.7) as shown in Figure -11

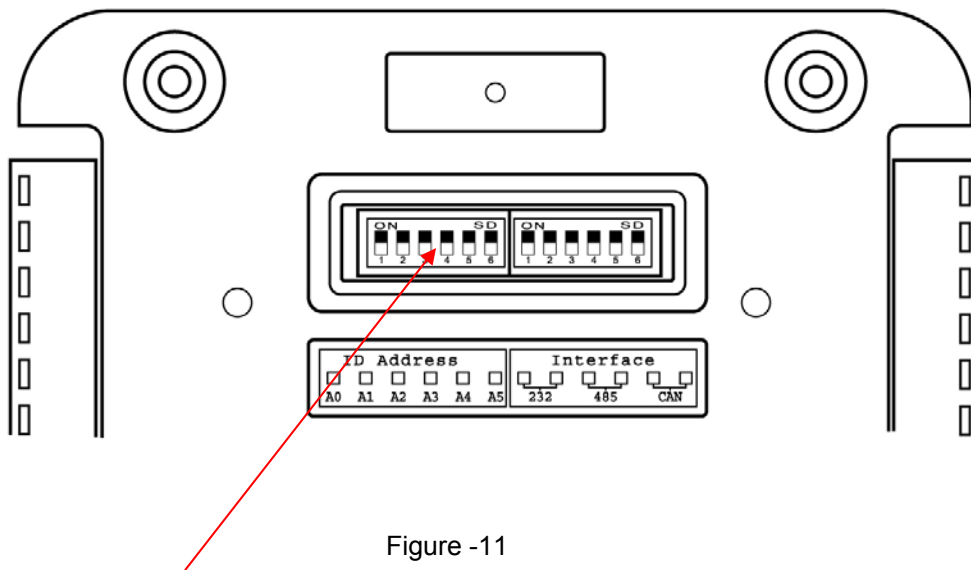

Figure -11

- 1、 Set all Pins of **ID address DIP switch** to off position (ID=00)
- 2、 Power off/on to re-boot the module and wait for a few seconds until USB LED or Ethernet LED turn-on
- 3、 Set the pins of **ID address DIP switch** to the desired position (ID=xx) (**ID=0 is reserved for setting default only**)
- 4、 Power off/on again to use default settings

Chapter 18 Zero/Span Calibration

18.1 EDAM-5015 Calibration

- 1、 Connect EDAM-5015 to USB hub
- 2、 Execute EDAM-5000Utility.
- 3、 Click **“Start”** button to search modules
- 4、 Double click EDAM-5015 listed in device list window

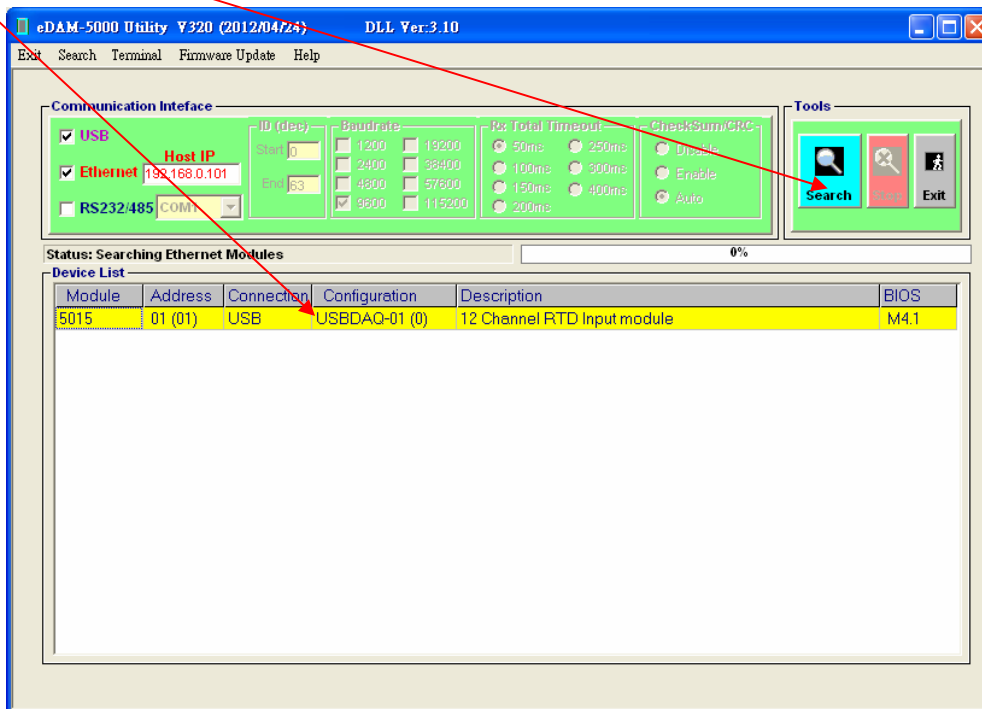
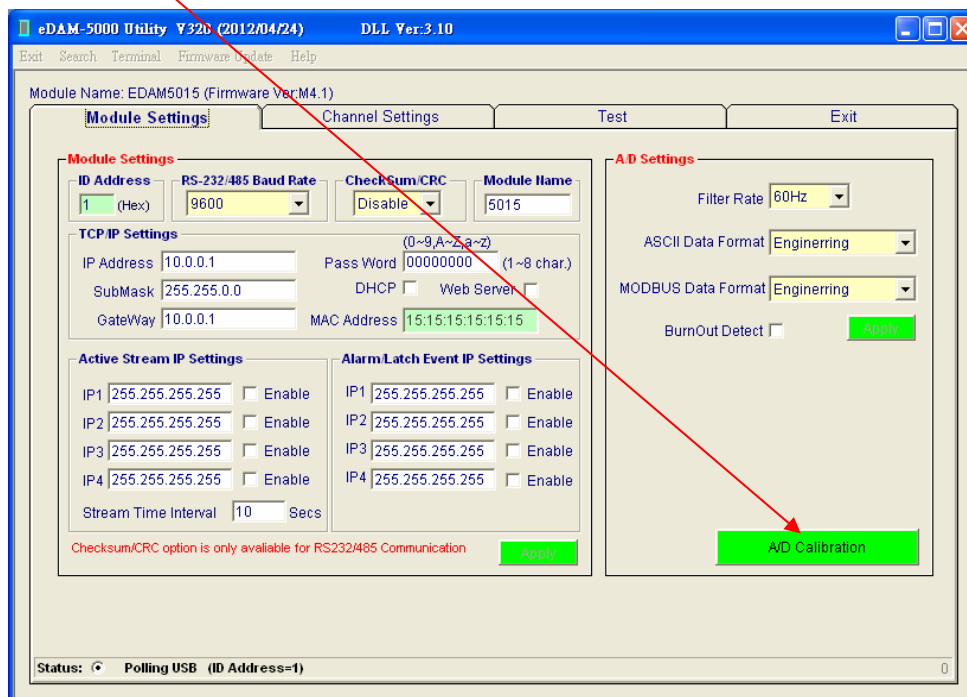

Figure -12

- 5、 Click **“A/D Calibration”** button



- 6、 Connect **0 ohm** resistor to channel #0 (**RTD0+, RTD0-, AGND**) as shown in Figure -13
- 7、 Connect a 120~180 ohms resistor for pt100 calibration ,1200~2000 ohms resistor for pt1000, or 500~650 ohms resistor for Balco500/Ni604 calibration to channel #1 (**RTD1+, RTD1-, AGND**) as shown in Figure -13

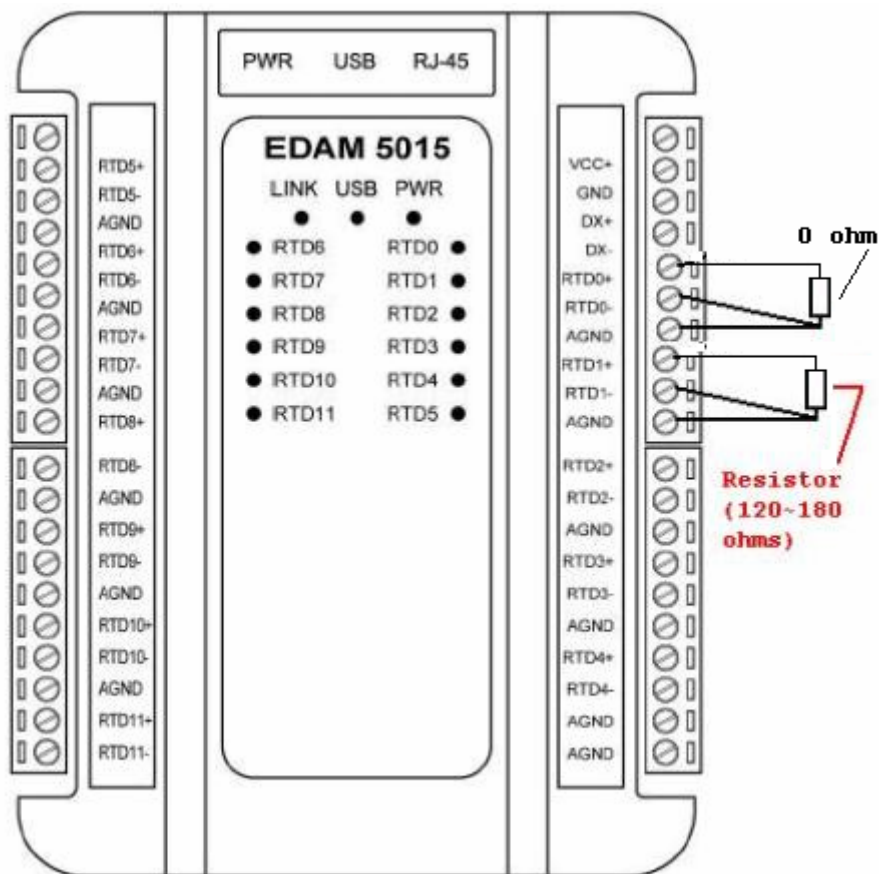
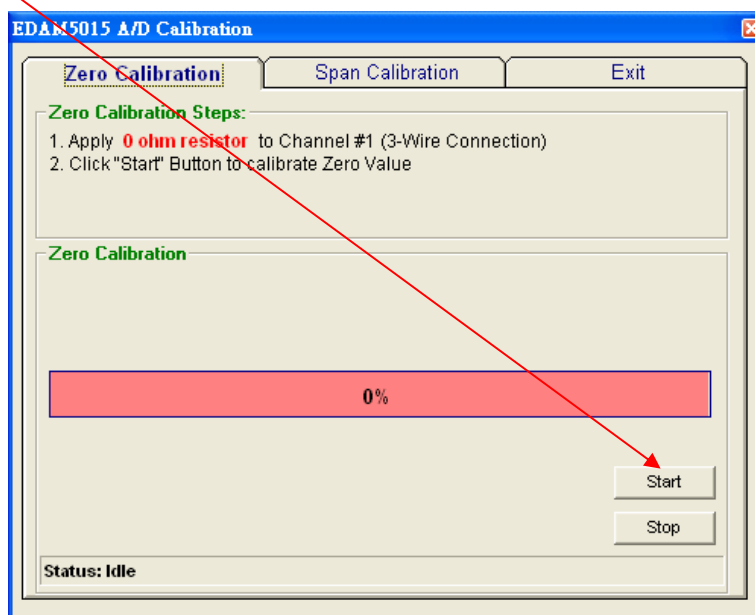
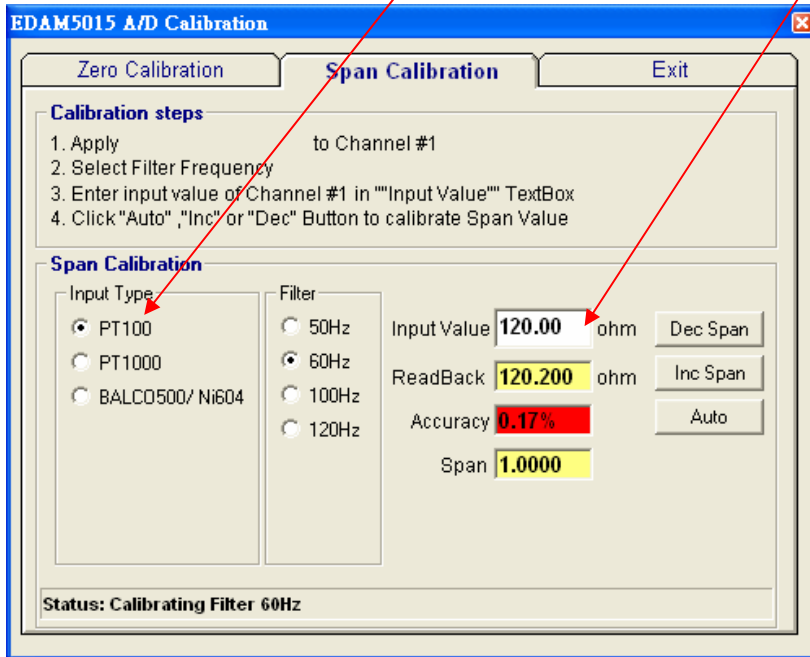

Figure -13

- 8、 Click **Start** button to calibrate Zero offset first



- 9、Click “Span Calibration” tab and Select “Input Type”
- 10、Enter the value of the resistor connected to channel #1 (RTD1+, RTD1-) in the “Input Value” textbox (120~200 ohms for PT100, 1200~2000 ohms for PT1000, or 500~600 ohms for Balco500/Ni604)



- 11、Click “Auto” button to start auto-calibrating
Auto-calibration will calibrate Span value of all Filter rate (50Hz, 60Hz, 100Hz, 120Hz)
- 12、You can also click “Inc Span” or “Dec Span” button to fine adjust the Span value

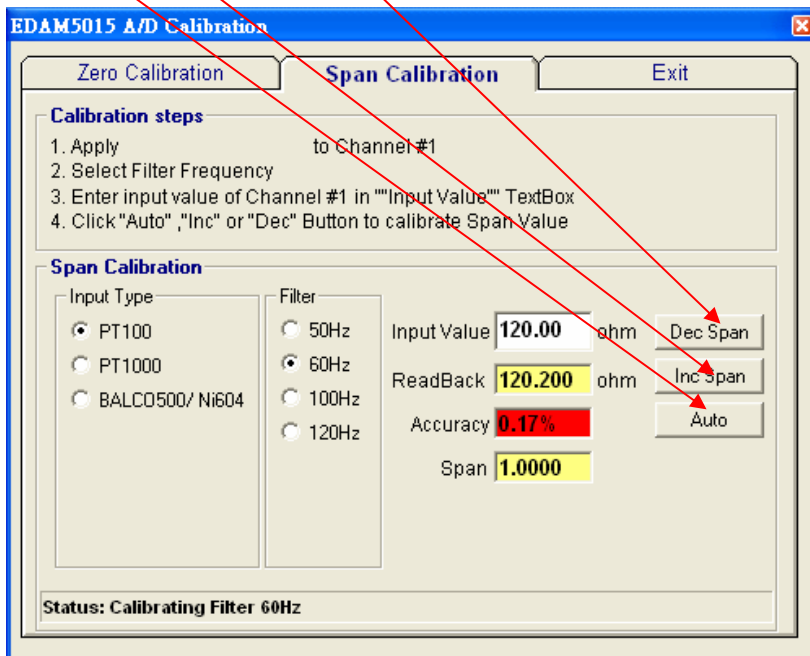

- 13、Click “Exit” button to exit calibration window

18.2 EDAM-5017 Calibration

- 1、 Connect EDAM5019 to USB hub
- 2、 Execute E5000Utility.
- 3、 Click “Start” button to search modules
- 4、 Double click EDAM-5017 listed in device list window

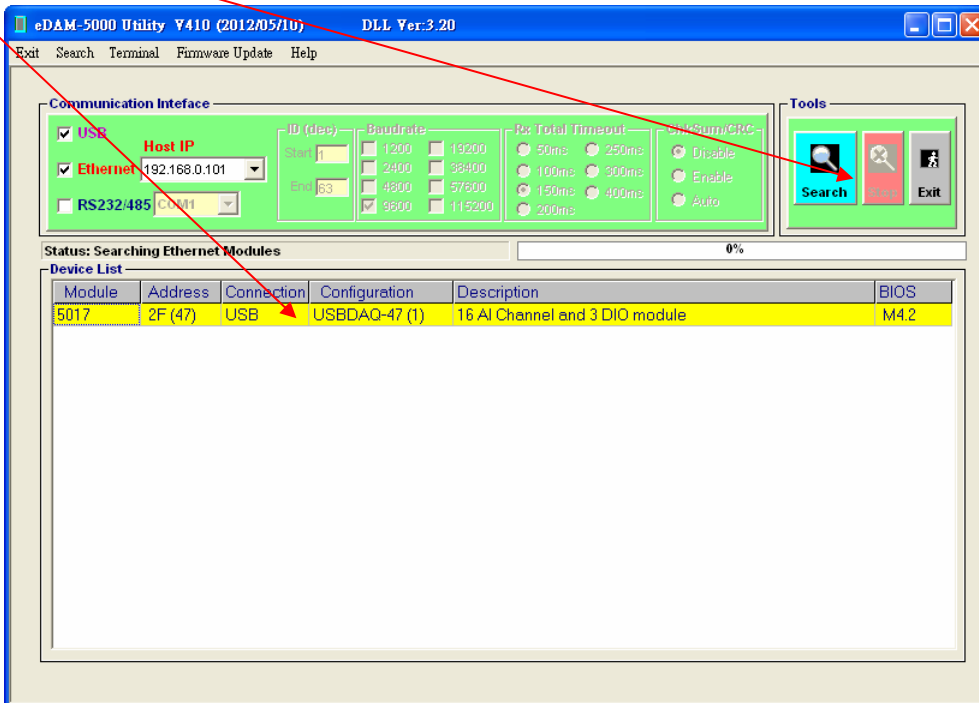

- 5、 Click “A/D Calibration” button

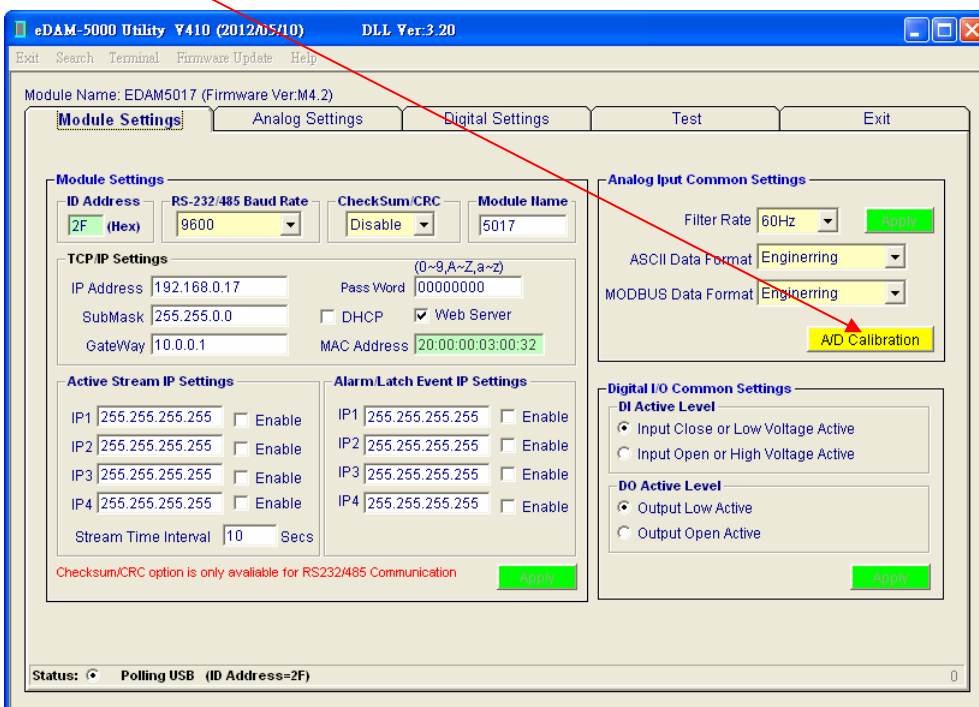

- 6、 Apply **0V** to channel **#0 (AI0+, AI0-)** as shown in Figure -14
- 7、 Apply proper voltage(depend on the type been calibrated) to channel **#1 (AI1+, AI1-)** as shown in Figure -14

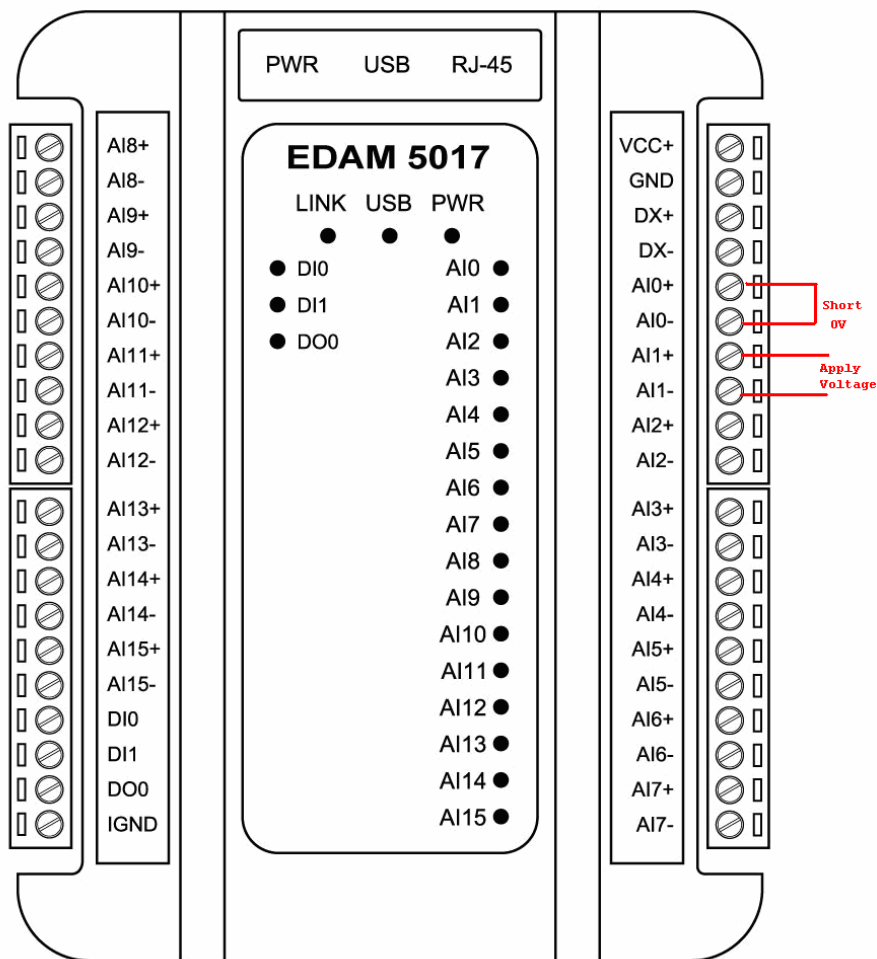
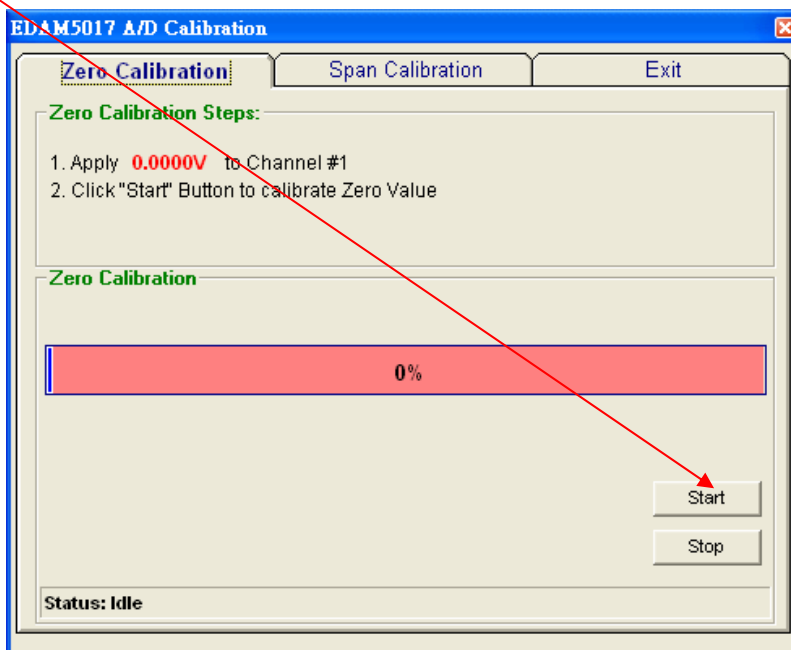

Figure -14

- 8、 Click **Start** button to calibrate Zero offset first



EDAM-5000 User's Manual

- Click **Span Calibration** tab and Select **Input Type**
- Enter the value of voltage(see [input range](#)) applied to channel #1 (**AI1+, AI1-**) in the **Input Value** textbox

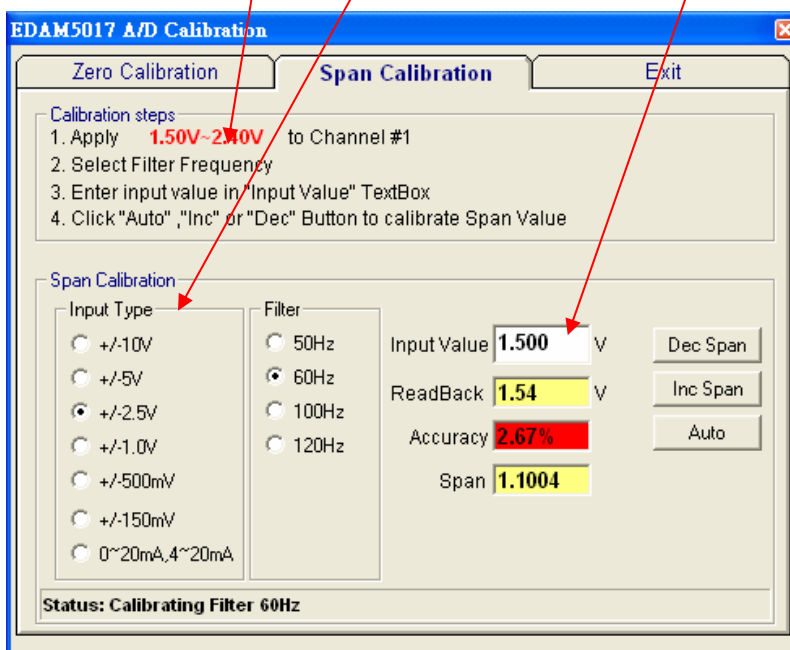

- Click **Auto** button to start auto-calibrating
Auto-calibration will calibrate Span value of all Filter rate (50Hz, 60Hz, 100Hz, 120Hz)
- You can also click **Inc Span** or **Dec Span** button to fine adjust the Span value

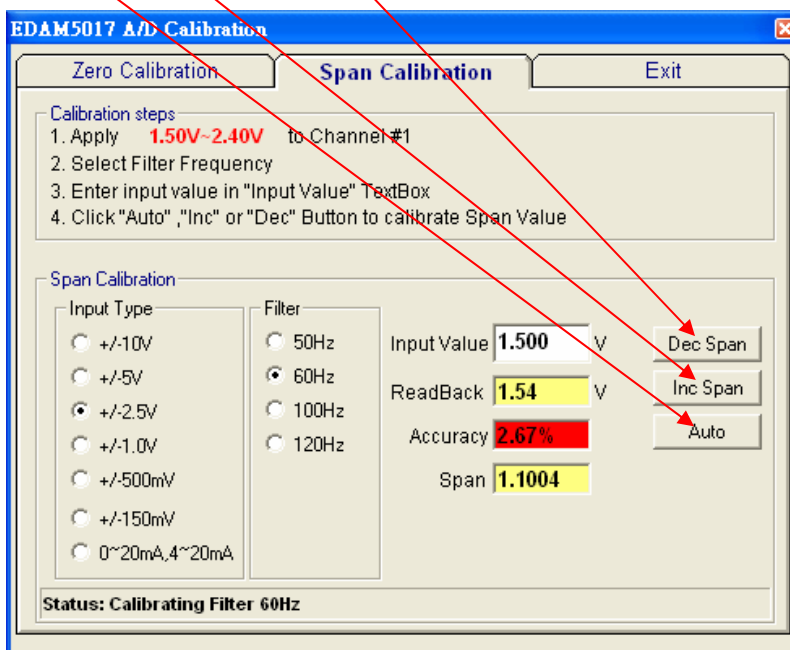

- Click **Exit** button to exit calibration window

18.3 EDAM-5019 Calibration

- 1、 Connect EDAM5019 to USB hub
- 2、 Execute E5000Utility.
- 3、 Click “Start” button to search modules
- 4、 Double click EDAM-5019 listed in device list window

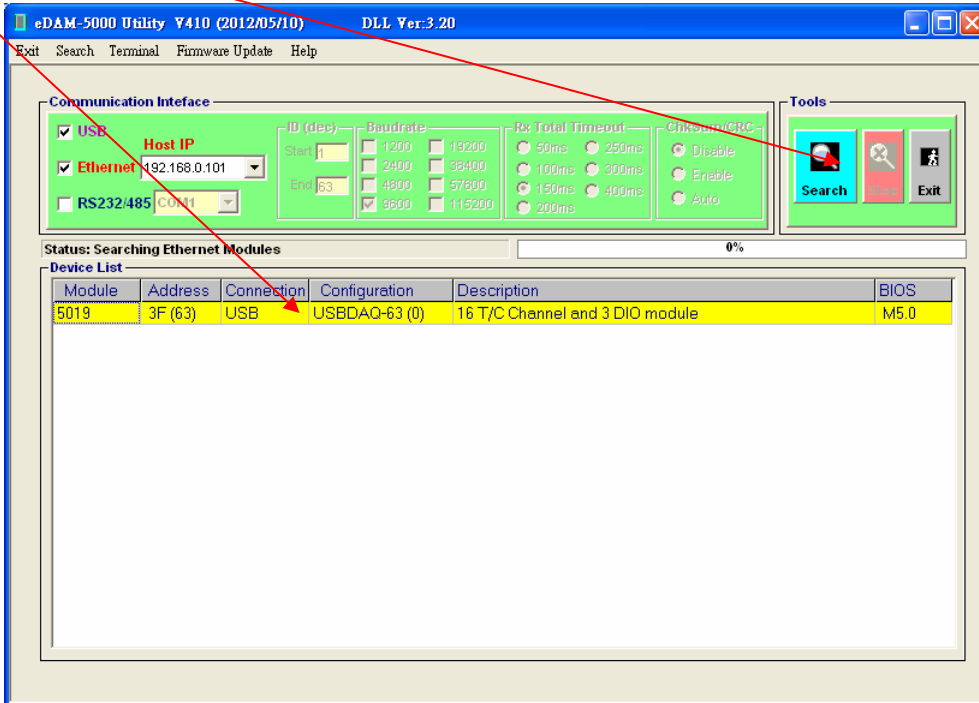

- 5、 Click “A/D Calibration” button

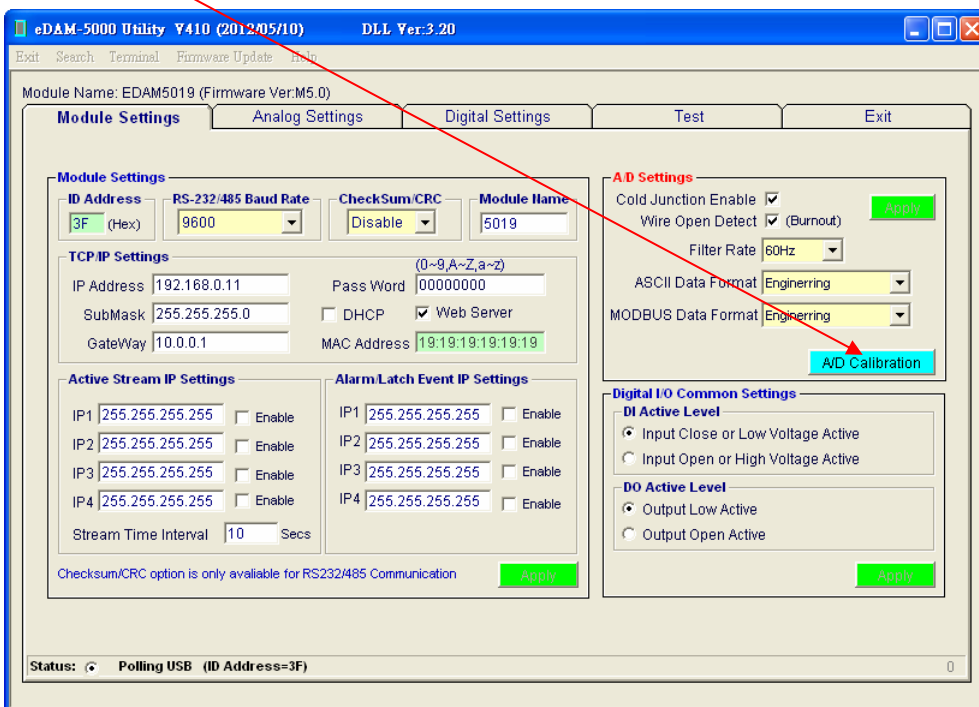

- 6、 Apply 0Vr to channel #0 (AI0+, AI0-) as shown in Figure -15
- 7、 Apply proper voltage(depend on the type been calibrated) to channel #1 (AI1+, AI1-) as shown in Figure -15

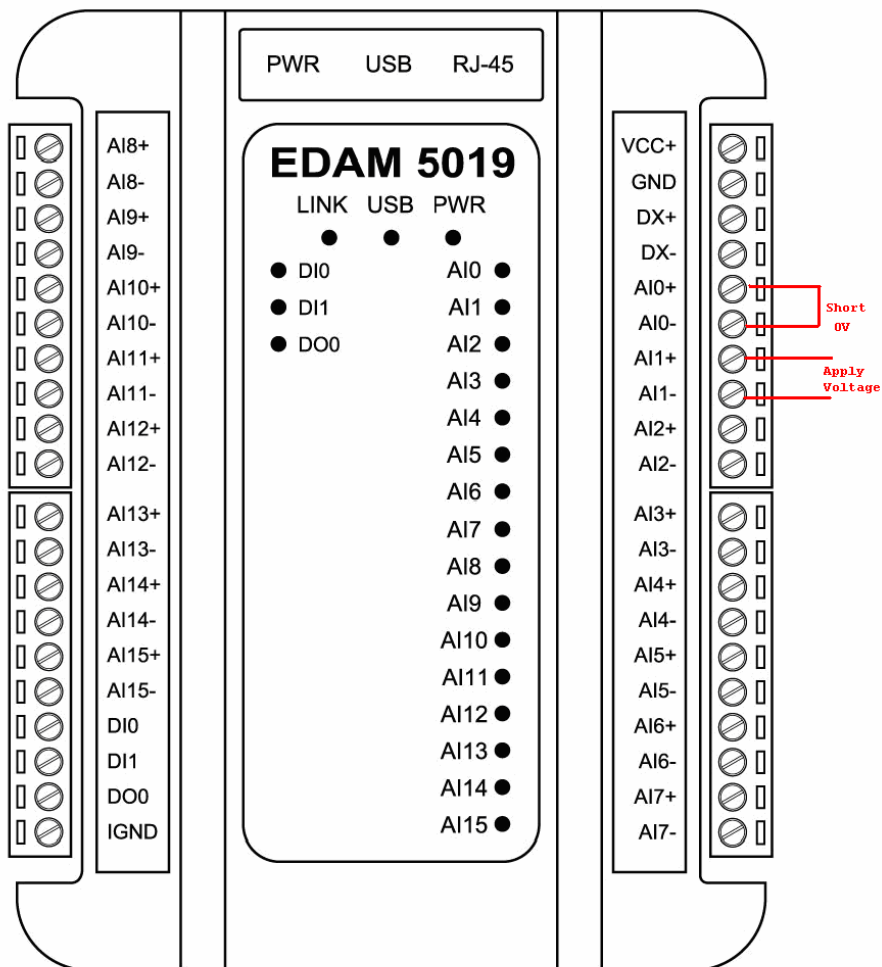
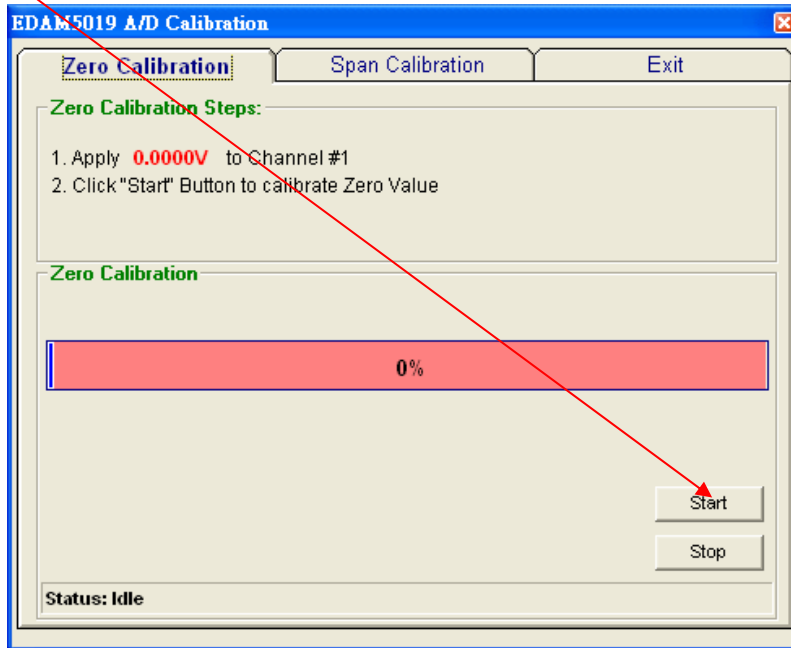
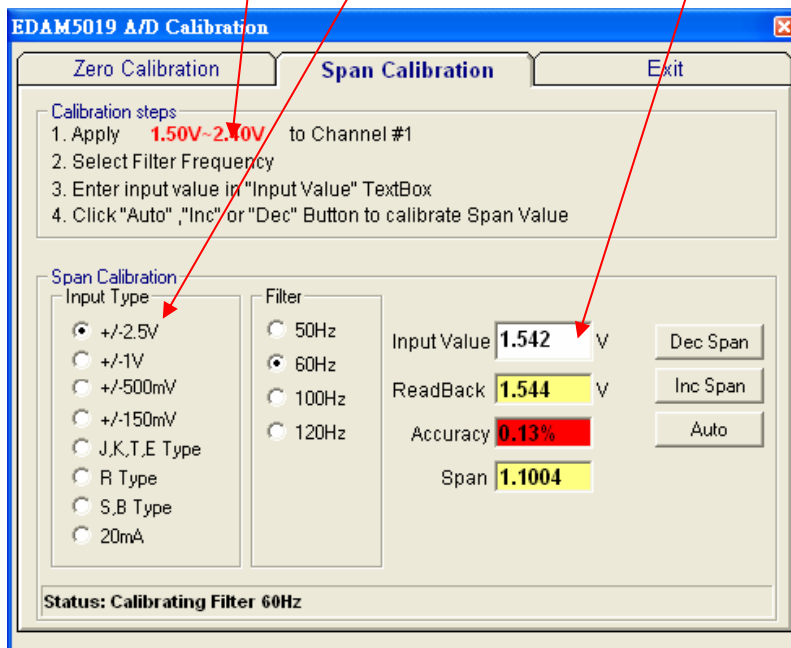

Figure -15

- 8、 Click "Start" button to calibrate Zero offset first



- 9、 Click "Span Calibration" tab and Select "Input Type"
- 10、 Enter the value of voltage(see input range) applied to channel #1 (CH1+, CH1-) in the "Input Value" textbox



- 11、Click **Auto** button to start auto-calibrating
Auto-calibration will calibrate Span value of all Filter rate (50Hz, 60Hz, 100Hz, 120Hz)
- 12、You can also click **Inc Span** or **Dec Span** button to fine adjust the Span value

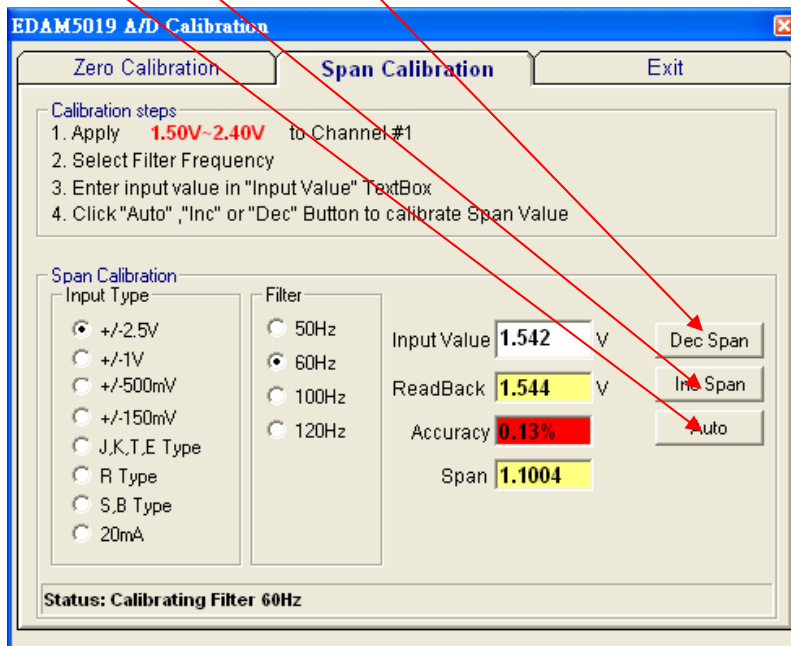

- 13、Click **Exit** button to exit calibration window