



**ADLINK**  
TECHNOLOGY INC.

## **cPCI-3E10 Series**

3U CompactPCI 4/2 Port  
Gigabit Ethernet Card

### **User's Manual**



**Manual Rev.:** 2.00  
**Revision Date:** November 15, 2011  
**Part No:** 50-15073-1000



Recycled Paper

**Advance Technologies; Automate the World.**

# Revision History

Revision	Release Date	Description of Change(s)
2.00	2011/11/15	Initial release

# Preface

## **Copyright 2011 ADLINK Technology Inc.**

This document contains proprietary information protected by copyright. All rights are reserved. No part of this manual may be reproduced by any mechanical, electronic, or other means in any form without prior written permission of the manufacturer.

## **Disclaimer**

The information in this document is subject to change without prior notice in order to improve reliability, design, and function and does not represent a commitment on the part of the manufacturer.

In no event will the manufacturer be liable for direct, indirect, special, incidental, or consequential damages arising out of the use or inability to use the product or documentation, even if advised of the possibility of such damages.

## **Environmental Responsibility**

ADLINK is committed to fulfill its social responsibility to global environmental preservation through compliance with the European Union's Restriction of Hazardous Substances (RoHS) directive and Waste Electrical and Electronic Equipment (WEEE) directive. Environmental protection is a top priority for ADLINK. We have enforced measures to ensure that our products, manufacturing processes, components, and raw materials have as little impact on the environment as possible. When products are at their end of life, our customers are encouraged to dispose of them in accordance with the product disposal and/or recovery programs prescribed by their nation or company.

## **Trademarks**

Product names mentioned herein are used for identification purposes only and may be trademarks and/or registered trademarks of their respective companies.

## Using this Manual

### Audience and Scope

The cPCI-3E10 User's Manual is intended for hardware technicians and systems operators with knowledge of installing, configuring and operating industrial grade single board computers.

### Manual Organization

This manual is organized as follows:

**Chapter 1, Introduction:** Introduces the cPCI-3E10 Series, its features, specifications and block diagrams.

**Chapter 2, Board Interfaces:** Describes the cPCI-3E10 board interfaces, pin definitions, and jumper settings.

**Chapter 3, Driver Installation:** Provides information on how to install the cPCI-3E10 drivers.

**Important Safety Instructions:** Presents safety instructions all users must follow for the proper setup, installation and usage of equipment and/or software.

**Getting Service:** Contact information for ADLINK's worldwide offices.

## Conventions

Take note of the following conventions used throughout this manual to make sure that users perform certain tasks and instructions properly.



NOTE:

Additional information, aids, and tips that help users perform tasks.

---



Information to prevent **minor** physical injury, component damage, data loss, and/or program corruption when trying to complete a task.

---



Information to prevent **serious** physical injury, component damage, data loss, and/or program corruption when trying to complete a specific task.

---

This page intentionally left blank.

# Table of Contents

<b>Revision History</b> .....	<b>ii</b>
<b>Preface</b> .....	<b>iii</b>
<b>List of Figures</b> .....	<b>ix</b>
<b>List of Tables</b> .....	<b>xi</b>
<b>1 Introduction</b> .....	<b>1</b>
1.1 Overview.....	1
1.2 Features.....	1
1.3 Specifications.....	2
1.4 I/O Connectivity Table .....	3
1.5 Block Diagrams.....	3
<b>2 Board Interfaces</b> .....	<b>5</b>
2.1 Board Layout .....	5
2.2 Connectors and Jumpers.....	9
<b>3 Driver Installation</b> .....	<b>13</b>
3.1 cPCI-3E10 Driver.....	13
<b>Important Safety Instructions</b> .....	<b>15</b>
<b>Getting Service</b> .....	<b>17</b>

This page intentionally left blank.



## List of Figures

Figure 1-1: cPCI-3E10 Block Diagram .....	3
Figure 1-2: cPCI-3E12 Block Diagram .....	4
Figure 1-3: cPCI-3E10-SUB Block Diagram .....	4
Figure 2-1: cPCI-3E10 Board Layout.....	5
Figure 2-2: cPCI-3E10 Front Panel.....	5
Figure 2-3: cPCI-3E12 Board Layout.....	6
Figure 2-4: cPCI-3E12 Front Panel.....	6
Figure 2-5: cPCI-3E10-SUB Board Layout .....	7
Figure 2-6: cPCI-3E10-SUB Front Panel .....	7
Figure 2-7: cPCI-R3E10 RTM Board Layout.....	8
Figure 2-8: cPCI-R3E10 RTM Front Panel .....	8

This page intentionally left blank.

## List of Tables

Table 1-1:	cPCI-3E10 Specifications .....	2
Table 2-1:	RJ-45 Pin Definitions .....	9
Table 2-2:	LAN Status LED Definitions.....	9
Table 2-3:	DB-9 LAN1/2 Connector Pin Definition.....	10
Table 2-4:	CompactPCI J1 Connector Pin Definition.....	11
Table 2-5:	CompactPCI J2 Connector Pin Definition.....	12

This page intentionally left blank.

# 1 Introduction

## 1.1 Overview

The cPCI-3E10 Series is 3U CompactPCI Gigabit Ethernet peripheral card equipped with Intel® 82574L PCIe Gigabit Ethernet controllers. The cPCI-3E10 provides four GbE ports on the front panel (RJ-45) with two switchable to the rear transition module, the cPCI-3E12 provides two GbE ports on the front panel (RJ-45), and the cPCI-3E10-SUB provides two Fast Ethernet ports on the front panel (DB-9).

An optional Rear Transition Module (cPCI-R3E10) is available to provide rear access to the GbE ports switched from the cPCI-3E10 front panel.

## 1.2 Features

- ▶ Standard 3U 4HP CompactPCI form factor
- ▶ Up to 64-bit/66MHz CompactPCI Interface
- ▶ Up to four Intel® 82574L Ethernet controllers with fully-integrated GbE MAC & PHY
- ▶ Four or two 10/100/1000BASE-T Gigabit Ethernet ports via RJ-45 connectors
- ▶ Two LAN ports switchable to rear (cPCI-3E10 only)
- ▶ Two Fast Ethernet ports via D-sub 9-pin connectors (cPCI-3E10-SUB only) for harsh environment applications
- ▶ PICMG® 2.0 R3.0 compliant



This product must be protected from static discharge and physical shock. Never remove any of the components except at a static-free workstation. Use the anti-static bag shipped with the product when putting the board on a surface. Wear an anti-static wrist strap properly grounded on one of the system's ESD ground jacks when installing or servicing system components.

---

## 1.3 Specifications

<b>PCI Bus Architecture</b>	<ul style="list-style-type: none"> <li>• Bus Type: PCI</li> <li>• Bus Width: 32- or 64-bit</li> <li>• Bus Speed: 33/66 MHz</li> <li>• PCI Voltage: 3.3V or 5V universal</li> </ul>
<b>Ethernet Controller</b>	<ul style="list-style-type: none"> <li>• Intel 82574L Gigabit Ethernet Controller running at PCIe 1.1 (2.5 GHz) x1</li> <li>• 4x GbE ports on cPCI-3E10, 2x GbE ports on cPCI-3E12</li> <li>• Data rates supported (per port): 10/100/1000 Mbps</li> <li>• IEEE Standard/Network Topology: 10BASE-T, 100BASE-TX, 1000BASE-T</li> <li>• IEEE 802.3ab compliant</li> </ul>
<b>Ethernet Ports</b>	<ul style="list-style-type: none"> <li>• cPCI-3E10/3E12: Four or two RJ-45 connectors</li> <li>• cPCI-3E10-SUB: Two DB-9 10/100 Mbps Fast LAN connectors</li> <li>• cPCI-R3E10: Two RJ-45 connectors</li> <li>• Wiring: Cat-5, 4-pair, Maximum 100 meters cable distance</li> </ul>
<b>Ethernet LEDs</b>	<ul style="list-style-type: none"> <li>• Each RJ-45 port and DB-9 port has two "Link/Active" LEDs</li> </ul>
<b>Boot ROM</b>	<ul style="list-style-type: none"> <li>• LAN Boot ROM: 128KB onboard</li> </ul>
<b>OS Support</b>	<ul style="list-style-type: none"> <li>• Microsoft Windows Server 2003 and 2008</li> <li>• Microsoft Windows XP, Vista, 7</li> <li>• Red Hat Enterprise Linux 5.0 and above (Contact ADLINK for other OS availability)</li> </ul>
<b>Network Management</b>	<ul style="list-style-type: none"> <li>• ACPI Power Management</li> <li>• Supports Intel Preboot Execution Environment (PXE 2.0) for remote boot</li> </ul>
<b>Environment</b>	<ul style="list-style-type: none"> <li>• Operating Temperature: 0°C to 60°C</li> <li>• Storage Temperature: -40°C to 70°C</li> <li>• Humidity: 95% @70°C, non-condensing</li> </ul>
<b>Dimensions</b>	<ul style="list-style-type: none"> <li>• 149 mm x 74 mm x 10 mm (L x W x H)</li> </ul>

**Note:** Specifications are subject to change without prior notice.

**Table 1-1: cPCI-3E10 Specifications**

## 1.4 I/O Connectivity Table

Function	Model	Faceplate
GbE (RJ-45)	cPCI-3E10	Y x4
	cPCI-3E12	Y x2
	cPCI-R3E10	Y x2
Fast Ethernet (DB-9)	cPCI-3E10-SUB	Y x2

## 1.5 Block Diagrams

### cPCI-3E10 Block Diagram

The cPCI-3E10 is based on four Intel® 82574L PCI express Gigabit Ethernet controllers. The Intel® 82574L is a highly integrated chip including Ethernet MAC and PHY. Please refer to the Intel® 82574L datasheet for more information.

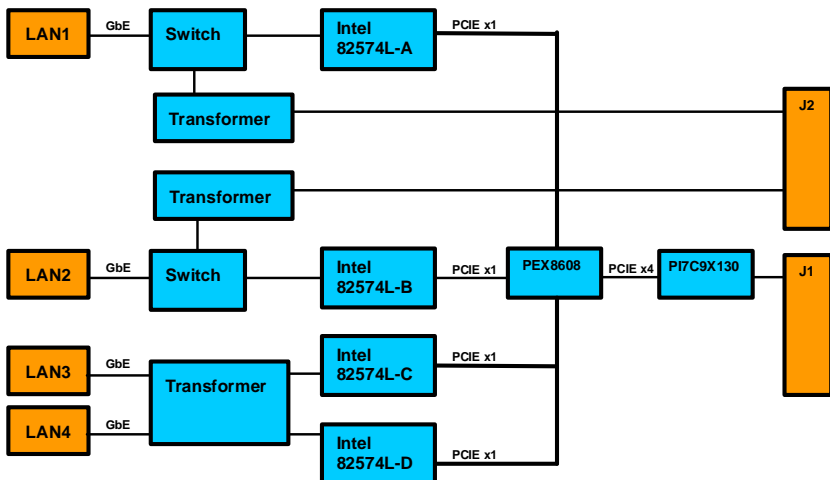

Figure 1-1: cPCI-3E10 Block Diagram

## cPCI-3E12 Block Diagram

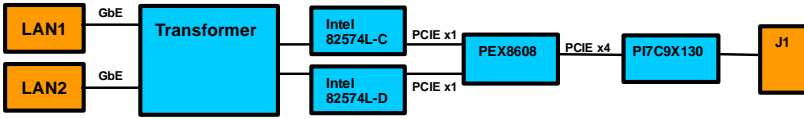

Figure 1-2: cPCI-3E12 Block Diagram

## cPCI-3E10-SUB Block Diagram

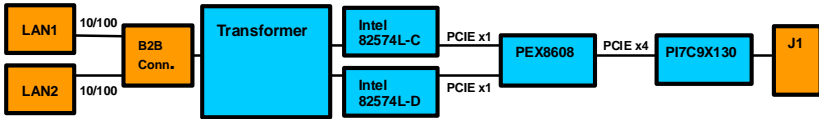

Figure 1-3: cPCI-3E10-SUB Block Diagram



## 2 Board Interfaces

This chapter illustrates the board layout, connector pin assignments, and jumper settings of the cPCI-3E10 Series.

### 2.1 Board Layout

#### cPCI-3E10 Board Layout

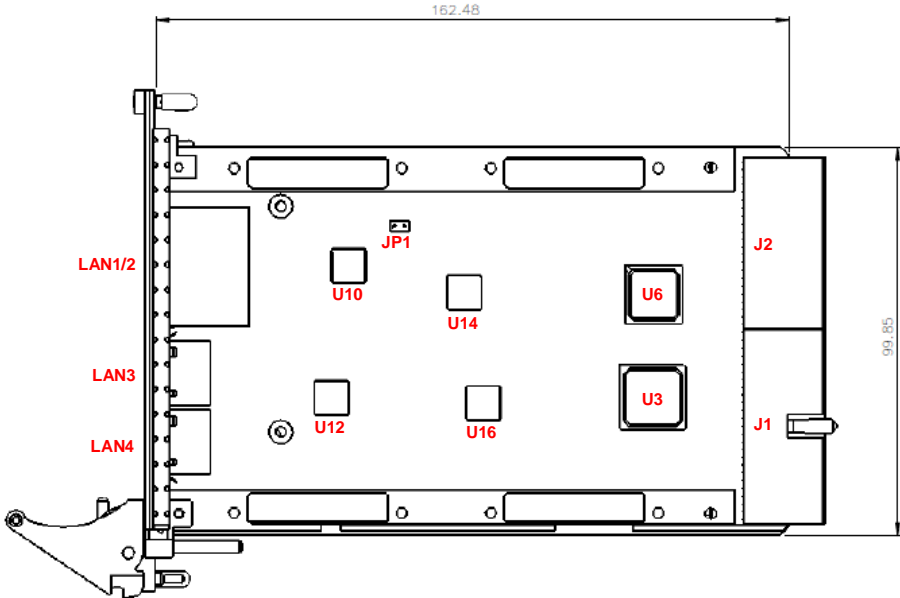

<b>JP1</b>	LAN routing jumper	<b>U3</b>	PCIe-to-PCI Bridge PI7C9X130
<b>J1/2</b>	CompactPCI connectors	<b>U6</b>	PCIe Switch PEX8608
<b>LAN1/2</b>	GbE ports (RJ-45 w/ transformer)	<b>U10/12/ 14/16</b>	Intel 82574L GbE controllers
<b>LAN3/4</b>	GbE ports (RJ-45)		

Figure 2-1: cPCI-3E10 Board Layout



Figure 2-2: cPCI-3E10 Front Panel

## cPCI-3E12 Board Layout

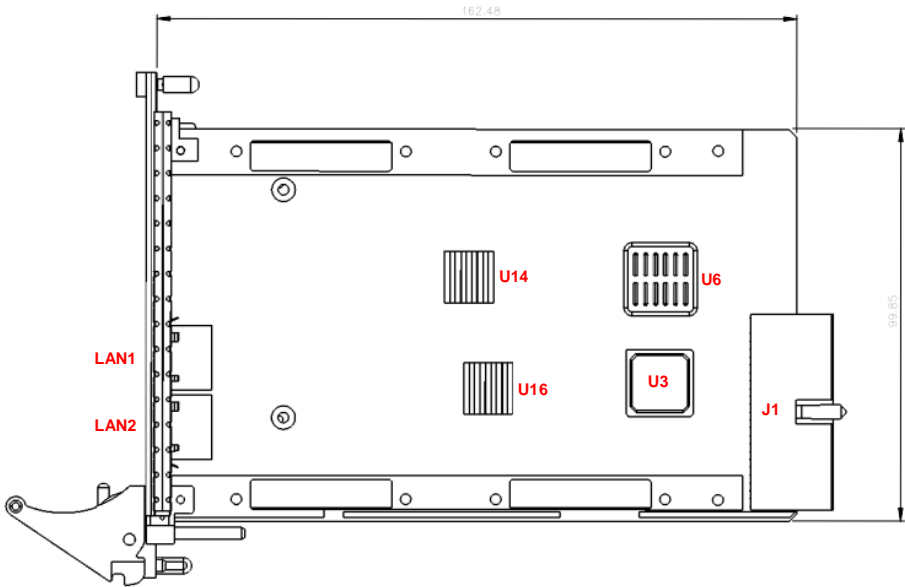

<b>U3</b>	PCIe-to-PCI Bridge PI7C9X130	<b>U6</b>	PCIe Switch PEX8608
<b>U14/16</b>	Intel 82574L GbE controllers	<b>LAN1/2</b>	GbE ports (RJ-45)
<b>J1</b>	CompactPCI connector		

**Figure 2-3: cPCI-3E12 Board Layout**

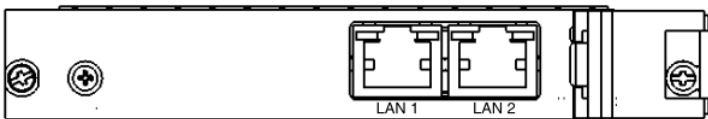

**Figure 2-4: cPCI-3E12 Front Panel**

## cPCI-3E10-SUB Board Layout

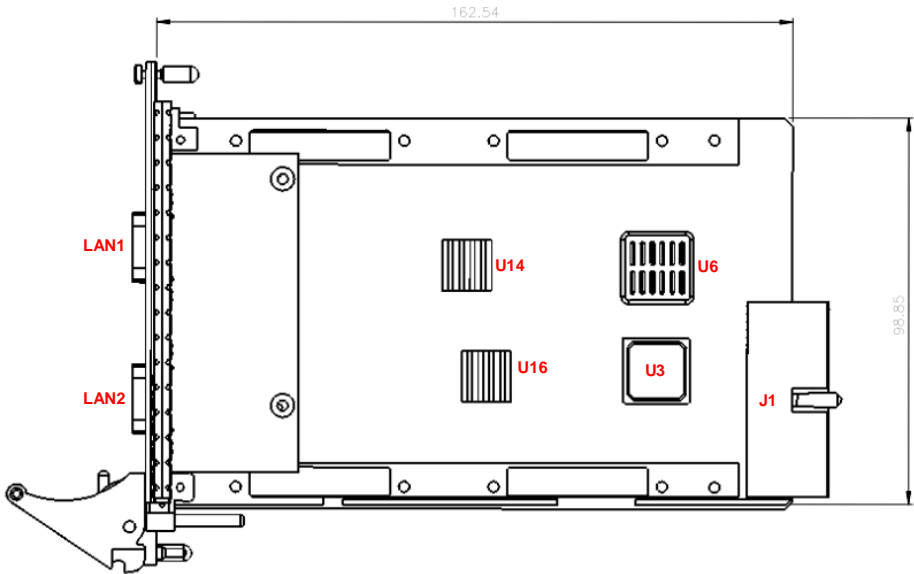

<b>U3</b>	PCIleto PCI Bridge PI7C9X130	<b>U6</b>	PCIe Switch PEX8608
<b>U14/16</b>	Intel 82574L GbE controllers	<b>LAN1/2</b>	Fast Ethernet (DB-9)
<b>J1</b>	CompactPCI connector		

**Figure 2-5: cPCI-3E10-SUB Board Layout**

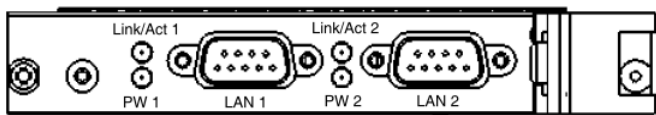

**Figure 2-6: cPCI-3E10-SUB Front Panel**

## cPCI-R3E10 RTM Board Layout

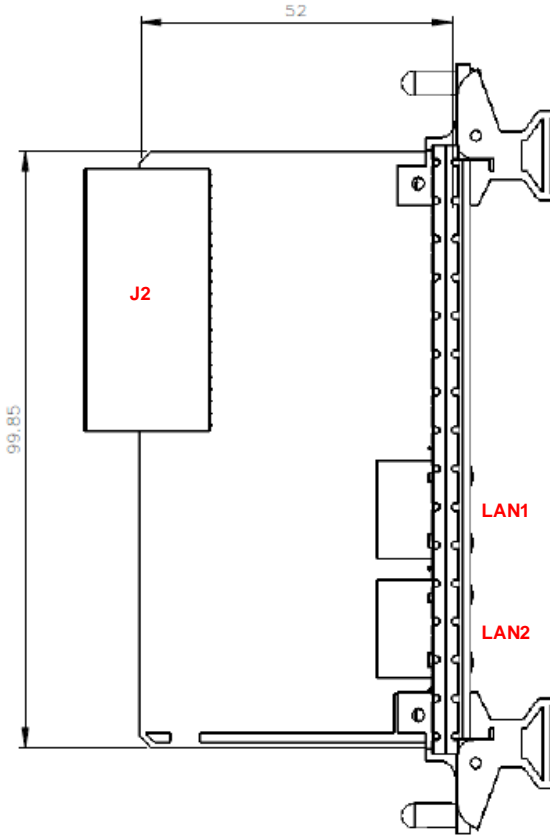

<b>J2</b>	CompactPCI connector	<b>LAN1/2</b>	GbE ports (RJ-45)
-----------	----------------------	---------------	-------------------

**Figure 2-7: cPCI-R3E10 RTM Board Layout**

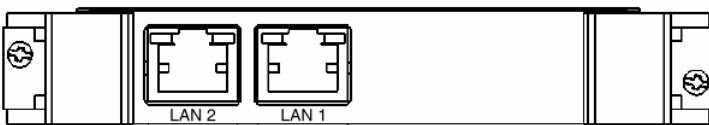

**Figure 2-8: cPCI-R3E10 RTM Front Panel**

## 2.2 Connectors and Jumpers

### RJ-45 Ethernet Connectors

On the cPCI-3E10, LAN1/2 correspond to "A/B", and LAN3/4 correspond to "C/D". On the cPCI-3E12, LAN1/2 correspond to "C/D". On the cPCI-R3E10 RTM, LAN1/2 correspond to "A/B".

Pin #	10BASE-T/ 100BASE-TX	1000BASE-T
1	TX+	TRANS_ A/B/C/D_MDIP0
2	TX-	TRANS_ A/B/C/D_MDIN0
3	RX+	TRANS_ A/B/C/D_MDIP1
4	—	TRANS_ A/B/C/D_MDIP2
5	—	TRANS_ A/B/C/D_MDIN2
6	RX-	TRANS_ A/B/C/D_MDIN1
7	—	TRANS_ A/B/C/D_MDIP3
8	—	TRANS_ A/B/C/D_MDIN3

Table 2-1: RJ-45 Pin Definitions

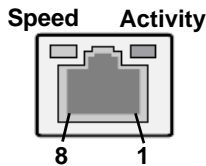

Status		Speed LED (Green/Orange)	Activity LED (Yellow)
Network link is not established or system powered off		OFF	OFF
10 Mbps	Link	OFF	ON
	Active	OFF	Blinking
100 Mbps	Link	Green	ON
	Active	Green	Blinking
1000 Mbps	Link	Orange	ON
	Active	Orange	Blinking

Table 2-2: LAN Status LED Definitions

## LAN Routing Jumper (JP1)

The cPCI-3E10 is equipped with a jumper JP1 to transfer LAN1/2 (82574L-A and 82574L-B) to J2 (RTM). See “cPCI-3E10 Board Layout” on page 5 for the location of JP1.

Short pins 1 and 2 on JP1 to route LAN1/2 to the front RJ-45 connectors (default). To route LAN1/2 to J2, remove the shunt shorting pins 1 and 2 (it can be placed on either pin for storage).

## LAN1/2 DB-9 Connector on cPCI-3E10-SUB

On the cPCI-3E10-SUB, LAN1/2 correspond to "C/D".

Pin #	Signal	Function
1	TRANS_C/D_MDIP0	TX+
2	GND	ground
3	GND	ground
4	GND	ground
5	TRANS_C/D_MDIP1	RX+
6	TRANS_C/D_MDIN0	TX-
7	GND	ground
8	GND	ground
9	TRANS_C/D_MDIN1	RX-

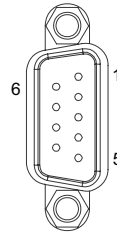

**Table 2-3: DB-9 LAN1/2 Connector Pin Definition**

## CompactPCI J1 Connector

Pin	Z	A	B	C	D	E	F
25	GND	P5V	CPCI_REQ64-L	CPCI_ENUM-L	P3V3	P5V	GND
24	GND	CPCI_AD1	P5V	NC	CPCI_AD0	CPCI_ACK64-L	GND
23	GND	P3V3	CPCI_AD4	CPCI_AD3	P5V	CPCI_AD2	GND
22	GND	CPCI_AD7	GND	P3V3	CPCI_AD6	CPCI_AD5	GND
21	GND	P3V3	CPCI_AD9	CPCI_AD8	PCI_M66EN	CPCI_CBE-L0	GND
20	GND	CPCI_AD12	GND	NC	CPCI_AD11	CPCI_AD10	GND
19	GND	P3V3	CPCI_AD15	CPCI_AD14	GND	CPCI_AD13	GND
18	GND	CPCI_SERR-L	GND	P3V3	CPCI_PAR	CPCI_CBE-L1	GND
17	GND	P3V3	IPMB_CLK	IPMB_DAT	GND	CPCI_PERR-L	GND
16	GND	CPCI_DEVSEL-L	GND	NC	CPCI_STOP-L	CPCI_LOCK-L	GND
15	GND	P3V3	CPCI_FRAME-L	CPCI_IRDY-L	GND	CPCI_TRDY-L	GND
12-14	Key						
11	GND	CPCI_AD18	CPCI_AD17	CPCI_AD16	GND	CPCI_CBE-L2	GND
10	GND	CPCI_AD21	GND	P3V3	CPCI_AD20	CPCI_AD19	GND
9	GND	CPCI_CBE-L3	CPCI_IDSEL	CPCI_AD23	GND	CPCI_AD22	GND
8	GND	CPCI_AD26	GND	NC	CPCI_AD25	CPCI_AD24	GND
7	GND	CPCI_AD30	CPCI_AD29	CPCI_AD28	GND	CPCI_AD27	GND
6	GND	CPCI_REQ-L0	GND	P3V3	CPCI_CLK	CPCI_AD31	GND
5	GND	NC	NC	CPCI_RST-L	GND	CPCI_GNT-L0	GND
4	GND	NC	NC	NC	NC	NC	GND
3	GND	CPCI_INTA-L	CPCI_INTB-L	CPCI_INTC-L	P5V	CPCI_INTD-L	GND
2	GND	CPCI_TCK	P5V	CPCI_TMS	NC	CPCI_TDI	GND
1	GND	P5V	NC	CPCI_TRST-L	NC	P5V	GND

**Table 2-4: CompactPCI J1 Connector Pin Definition**

## CompactPCI J2 Connector

Pin	Z	A	B	C	D	E	F
22	GND	N28342162	N28355309	N28355465	N28355622	N28346930	GND
21	GND	NC	GND	NC	NC	NC	GND
20	GND	NC	GND	NC	GND	NC	GND
19	GND	GND	GND	NC	NC	NC	GND
18	GND	NC	NC	NC	GND	NC	GND
17	GND	NC	GND	NC	NC	NC	GND
16	GND	NC	NC	NC	GND	NC	GND
15	GND	NC	GND	NC	NC	NC	GND
14	GND	NC	NC	NC	GND	NC	GND
13	GND	P1V8_LANB	GND	NC	NC	P1V8_LANA	GND
12	GND	LANB_LED _100-L	LANB_LED _1000-L	LANB_LED _ACT-L	GND	LANA_LED _ACT-L	GND
11	GND	NC	N28043456	NC	P3V3	P5V	GND
10	GND	NC	NC	NC	N28028706	NC	GND
9	GND	GND	GND	LANA_LED _100-L	LANA_LED _1000-L	NC	GND
8	GND	TRANS_J2_B _MDIP2	TRANS_J2_B _MDIN2	GND	GND	GND	GND
7	GND	GND	GND	GND	TRANS_J2_A _MDIP2	TRANS_J2_A _MDIN2	GND
6	GND	TRANS_J2_B _MDIP3	TRANS_J2_B _MDIN3	GND	GND	GND	GND
5	GND	GND	GND	GND	TRANS_J2_A _MDIP3	TRANS_J2_A _MDIN3	GND
4	GND	TRANS_J2_B _MDIP0	TRANS_J2_B _MDIN0	GND	GND	GND	GND
3	GND	GND	GND	GND	TRANS_J2_A _MDIP0	TRANS_J2_A _MDIN0	GND
2	GND	TRANS_J2_B _MDIP1	TRANS_J2_B _MDIN1	GND	GND	GND	GND
1	GND	GND	GND	GND	TRANS_J2_A _MDIP1	TRANS_J2_A _MDIN1	GND

**Table 2-5: CompactPCI J2 Connector Pin Definition**



## 3 Driver Installation

The cPCI-3E10 drivers are available from the ADLINK All-In-One DVD at **X:\cPCI\cPCI-3E10\**, or from the ADLINK website (<http://www.adlinktech.com>). ADLINK provides validated drivers for Windows XP and Windows Server 2003/2008. We recommend using these drivers to ensure compatibility. Driver installation is not required for Windows Vista/7 and Red Hat Enterprise Linux.

The validated Windows driver installation files are as follows:

<b>Windows XP, Server 2003</b>	Intel_Network_Adapter_WinXP2K332_x14.5.exe
<b>Windows Server 2008</b>	Intel_Network_Adapter_Win2K832.exe

### 3.1 cPCI-3E10 Driver

The following describes the cPCI-3E10 driver installation procedure.

1. Install the Windows operating system before installing any driver. Most standard I/O device drivers are installed during Windows installation.
2. Select the correct file for your operating system and run the program to install the driver.
3. Follow the on screen instructions and reboot the system if requested to do so.

This page intentionally left blank.

# Important Safety Instructions

For user safety, please read and follow all **instructions**, **WARNINGS**, **CAUTIONS**, and **NOTES** marked in this manual and on the associated equipment before handling/operating the equipment.

- ▶ Read these safety instructions carefully.
- ▶ Keep this user's manual for future reference.
- ▶ Read the specifications section of this manual for detailed information on the operating environment of this equipment.
- ▶ When installing/mounting or uninstalling/removing equipment:
  - ▷ Turn off power and unplug any power cords/cables.
- ▶ To avoid electrical shock and/or damage to equipment:
  - ▷ Keep equipment away from water or liquid sources;
  - ▷ Keep equipment away from high heat or high humidity;
  - ▷ Keep equipment properly ventilated (do not block or cover ventilation openings);
  - ▷ Make sure to use recommended voltage and power source settings;
  - ▷ Always install and operate equipment near an easily accessible electrical socket-outlet;
  - ▷ Secure the power cord (do not place any object on/over the power cord);
  - ▷ Only install/attach and operate equipment on stable surfaces and/or recommended mountings; and,
  - ▷ If the equipment will not be used for long periods of time, turn off and unplug the equipment from its power source.

- ▶ Never attempt to fix the equipment. Equipment should only be serviced by qualified personnel.

A Lithium-type battery may be provided for uninterrupted, backup or emergency power.

---



Risk of explosion if battery is replaced with one of an incorrect type. Dispose of used batteries appropriately.

---

- ▶ Equipment must be serviced by authorized technicians when:
  - ▷ The power cord or plug is damaged;
  - ▷ Liquid has penetrated the equipment;
  - ▷ It has been exposed to high humidity/moisture;
  - ▷ It is not functioning or does not function according to the user's manual;
  - ▷ It has been dropped and/or damaged; and/or,
  - ▷ It has an obvious sign of breakage.

# Getting Service

Contact us should you require any service or assistance.

## **ADLINK Technology, Inc.**

Address: 9F, No.166 Jian Yi Road, Zhonghe District  
New Taipei City 235, Taiwan  
新北市中和區建一路 166 號 9 樓

Tel: +886-2-8226-5877  
Fax: +886-2-8226-5717  
Email: [service@adlinktech.com](mailto:service@adlinktech.com)

## **Ampro ADLINK Technology, Inc.**

Address: 5215 Hellyer Avenue, #110, San Jose, CA 95138, USA  
Tel: +1-408-360-0200  
Toll Free: +1-800-966-5200 (USA only)  
Fax: +1-408-360-0222  
Email: [info@adlinktech.com](mailto:info@adlinktech.com)

## **ADLINK Technology (China) Co., Ltd.**

Address: 上海市浦东新区张江高科技园区芳春路 300 号 (201203)  
300 Fang Chun Rd., Zhangjiang Hi-Tech Park,  
Pudong New Area, Shanghai, 201203 China

Tel: +86-21-5132-8988  
Fax: +86-21-5132-3588  
Email: [market@adlinktech.com](mailto:market@adlinktech.com)

## **ADLINK Technology Beijing**

Address: 北京市海淀区上地东路 1 号盈创动力大厦 E 座 801 室(100085)  
Rm. 801, Power Creative E, No. 1, B/D  
Shang Di East Rd., Beijing, 100085 China

Tel: +86-10-5885-8666  
Fax: +86-10-5885-8625  
Email: [market@adlinktech.com](mailto:market@adlinktech.com)

## **ADLINK Technology Shenzhen**

Address: 深圳市南山区科技园南区高新南七道 数字技术园  
A1 栋 2 楼 C 区 (518057)  
2F, C Block, Bldg. A1, Cyber-Tech Zone, Gao Xin Ave. Sec. 7,  
High-Tech Industrial Park S., Shenzhen, 518054 China

Tel: +86-755-2643-4858  
Fax: +86-755-2664-6353  
Email: [market@adlinktech.com](mailto:market@adlinktech.com)

**ADLINK Technology (Europe) GmbH**

Address: Nord Carree 3, 40477 Duesseldorf, Germany  
Tel: +49-211-495-5552  
Fax: +49-211-495-5557  
Email: [emea@adlinktech.com](mailto:emea@adlinktech.com)

**ADLINK Technology, Inc. (French Liaison Office)**

Address: 15 rue Emile Baudot, 91300 Massy CEDEX, France  
Tel: +33 (0) 1 60 12 35 66  
Fax: +33 (0) 1 60 12 35 66  
Email: [france@adlinktech.com](mailto:france@adlinktech.com)

**ADLINK Technology Japan Corporation**

Address: 〒101-0045 東京都千代田区神田鍛冶町 3-7-4  
神田 374 ビル 4F  
KANDA374 Bldg. 4F, 3-7-4 Kanda Kajicho,  
Chiyoda-ku, Tokyo 101-0045, Japan  
Tel: +81-3-4455-3722  
Fax: +81-3-5209-6013  
Email: [japan@adlinktech.com](mailto:japan@adlinktech.com)

**ADLINK Technology, Inc. (Korean Liaison Office)**

Address: 서울시 서초구 서초동 1675-12 모인터빌딩 8층  
8F Mointer B/D,1675-12, Seocho-Dong, Seocho-Gu,  
Seoul 137-070, Korea  
Tel: +82-2-2057-0565  
Fax: +82-2-2057-0563  
Email: [korea@adlinktech.com](mailto:korea@adlinktech.com)

**ADLINK Technology Singapore Pte. Ltd.**

Address: 84 Genting Lane #07-02A, Cityneon Design Centre,  
Singapore 349584  
Tel: +65-6844-2261  
Fax: +65-6844-2263  
Email: [singapore@adlinktech.com](mailto:singapore@adlinktech.com)

**ADLINK Technology Singapore Pte. Ltd. (Indian Liaison Office)**

Address: No. 1357, "Anupama", Sri Aurobindo Marg, 9th Cross,  
JP Nagar Phase I, Bangalore - 560078, India  
Tel: +91-80-65605817  
Fax: +91-80-22443548  
Email: [india@adlinktech.com](mailto:india@adlinktech.com)