

cPCI-3938

cPCI-6968/6969

Intelligent Multi-port Controller Module
8 Port Expansion Communication Module

@Copyright 1998~2000 ADLink Technology Inc.
All Rights Reserved.

Manual Rev 1.00: November 05, 1999

The information in this document is subject to change without prior notice in order to improve reliability, design and function and does not represent a commitment on the part of the manufacturer.

In no event will the manufacturer be liable for direct, indirect, special, incidental, or consequential damages arising out of the use or inability to use the product or documentation, even if advised of the possibility of such damages.

This document contains proprietary information protected by copyright. All rights are reserved. No part of this manual may be reproduced by any mechanical, electronic, or other means in any form without prior written permission of the manufacturer.

Trademarks

cPCI-3938, cPCI-6968 and cPCI-6969 are registered trademarks of ADLink Technology Inc., MS-DOS, Windows 95, Windows NT are registered trademark of Microsoft Corporation. Intel is a registered trademark of Intel Corporation. Other product names mentioned herein are used for identification purposes only and may be trademarks and/or registered trademarks of their respective companies.

Getting service from ADLink

- ◆ **Customer Satisfaction is always the most important thing for ADLink Tech Inc. If you need any help or service, please contact us and get it.**

ADLink Technology Inc.			
Web Site	http://www.adlink.com.tw		
Sales & Service	service@adlink.com.tw		
Technical	NuDAQ	nudaq@adlink.com.tw	
Support	NuDAM	nudam@adlink.com.tw	
	NuIPC	nuipc@adlink.com.tw	
	NuPRO	nupro@adlink.com.tw	
	Software	sw@adlink.com.tw	
	AMB	amb@adlink.com.tw	
TEL	+886-2-82265877	FAX	+886-2-82265717
Address	9F, No. 166, Jian Yi Road, Chunggho City, Taipei, 235 Taiwan, R.O.C.		

- ◆ **Please inform or FAX us of your detailed information for a prompt, satisfactory and constant service.**

Detailed Company Information			
Company/Organization			
Contact Person			
E-mail Address			
Address			
Country			
TEL		FAX	
Web Site			
Questions			
Product Model			
Environment to Use	<input type="checkbox"/> OS : _____ <input type="checkbox"/> Computer Brand : _____ <input type="checkbox"/> M/B : _____ <input type="checkbox"/> CPU : _____ <input type="checkbox"/> Chipset : _____ <input type="checkbox"/> Bios : _____ <input type="checkbox"/> Video Card : _____ <input type="checkbox"/> Network Interface Card : _____ <input type="checkbox"/> Other : _____		
Challenge Description			
Suggestions for ADLink			

CONTENTS

CONTENTS	1
CHAPTER 1 INTRODUCTION	1
1.1 ABOUT THE SERIAL COMMUNICATION MODULES	1
1.2 OVERVIEW OF cPCI-3938	2
1.2.1 What is cPCI-3938?.....	2
1.2.2 Feature of cPCI-3938.....	2
1.2.3 Specification of cPCI-3938.....	2
1.2.4 Connector Pin Assignment of cPCI-3938.....	3
1.2.5 LED Indicator of cPCI-3938.....	4
CHAPTER 2 INSTALLATION	5
2.1 WHAT YOU HAVE.....	5
2.2 UNPACKING.....	5
2.3 INSTALLATION PROCEDURE.....	6
2.4 HARDWARE CONFIGURATION.....	7
2.5 SOFTWARE INSTALLATION.....	7
2.5.1 Windows NT Installation	7
2.5.2 UNIX/XENIX Installation.....	8
CHAPTER 3 EXPANSION/ISOLATION MODULE USER GUIDE	15
3.1 INTRODUCTION.....	15
3.2 PIN DEFINITION / DIP SWITCH SETTING	19
PRODUCT WARRANTY/SERVICE	29

Introduction

1.1 About the Serial Communication Modules

The serial communication modules are intelligent serial input/output multi-port controller cards, which are with the new generation of PC platform CompactPCI. The modules can reduce the interval for serial communication controller to interrupt main CPU on the mainboard to improve the whole system performance.

Traditionally, the serial communication controller will interrupt the MPU character by character. This action will waste MPU processing time and drop the system computing power. If the MPU is processing some non-interrupted task, then the serial controller will overrun and data lost.

The serial communication interface series can support buffer capability or local processor and dual port RAM in each port's transmit and receive channel simultaneously. This capability will reduce the number of interrupt and increase the non-interrupt task's interval.

The serial communication interface series used ASIC PCI controller to interface the module to Compact PCI bus. The ASIC fully implement the PCI local bus specification Rev. 2.1. All bus relative configurations, such as base memory address and interrupt assignment, are automatically controlled by BIOS software. It does not need any user interaction and pre-study for the configurations. This removes the burden of searching for a conflict-free configuration.

1.2 Overview of cPCI-3938

1.21 What is cPCI-3938?

The cPCI-3938 is an intelligent serial port controller module used for Compact PCI platform. It includes a local high performance processor to manage the data flow between main CPU and external interface. It also includes dual port RAM, through the dual port RAM, the local processor can communicate with main CPU.

The LED indicators in the front are for self-diagnosis and network status, and it use rear IO to connect external I/O ports, all the I/O interface control circuitry and connector are built in one expansion module. There are different modules for different interface and control function requirement.

1.2.2 Feature of cPCI-3938

- 32-bit CompactPCI form factor
- PCI Rev.2.1 Plug and Play
- IRQ and IO address automatically assigned by PCI plug-n-play
- Built-in Intel i960 RISC local processor, a faster and powerful workstation grade 32-bit processor
- Suitable for modems, data display, data collection, telecommunication
- Modular structure, easy to setup and expand ports
- Expand from 8 serial ports to 64 serial ports in just 5 second
- Supports up to 2 cards/128 ports per system
- Supports Windows NT & UNIX/XENIX operation system

1.2.3 Specification of cPCI-3938

- Compliant with PCI Spec.2.1
- System Processor:
 - Intel 80960KA
 - 20 MHz
- 128K byte dual port RAM
- A system includes one controller module and at least one expansion module
- At most 8 expansion modules in one system
- System IO mapping:
 - Assigned by PCI BIOS
 - Shared IRQ

- Port Capability:
- 8 independent RS-232C compatible ports for cPCI-6969 expansion module
- 8 independent isolated RS-232/422/485 compatible ports for cPCI-6968 expansion module
- Operation System Compatibility: Windows NT, UNIX/XENIX
- Connector: Rear IO connector
- Operating temperature: 0 ~ 60 °C
- Storage temperature: -10 ~ 70 °C
- Humidity: 5% ~ 90%, non-condensing
- Power consumption: +5V @ 1400mA typical

1.2.4 Connector Pin Assignment of cPCI-3938

J2 connector pin assignment for cPCI-3938

22	GND	GA4	GA3	GA2	GA1	GA0	GND	P2 / J2 CONNECTOR
21	GND	LAD0	SG	LAD1	SG	LAD2	GND	
20	GND	LAD3	SG	LAD4	SG	LAD5	GND	
19	GND	LAD6	SG	LAD7	SG	LA0	GND	
18	GND	LA1	SG	LA2	SG	LA3	GND	
17	GND	LA4	SG	LA5	SG	LA6	GND	
16	GND	LA7	SG	LA8	SG	LCE#	GND	
15	GND	LWR#	SG	LRD#	SG	LRST	GND	
14	GND	LINT1	SG	LINT2	SG	LINT3	GND	
13	GND	LINT4	5V	5V	+12V	-12V	GND	
12	GND	5V	5V	5V	+12V	-12V	GND	
11	GND						GND	
10	GND						GND	
9	GND						GND	
8	GND						GND	
7	GND						GND	
6	GND						GND	
5	GND						GND	
4	GND						GND	
3	GND						GND	
2	GND						GND	
1	GND						GND	
Pin	Z	A	B	C	D	E	F	

1.2.5 LED Indicator of cPCI-3938

There are 4 LED on the cPCI-3938, Power(Green), Reset(Red), Fail(Red) and Active(Red).

	ON	OFF
Power	Power is applied on the module	No power
Reset	The module is in reset mode	The module is in operation mode
Fail	The module fail to pass the self-diagnostic	The module pass the self-diagnostic function
Active	At least one expansion module connect and can be active by the controller module	There is not expansion module connect with the controller module

2

Installation

This chapter describes the configurations of the serial communication modules. At first, the contents in the package and unpacking information that you should care about are described. The serial communication cards are plug-and-play and very easy to install into any cPCI system.

2.1 What You Have

In addition to this *User's Manual*, the package includes the following items:

- cPCI-3938 Serial Communication Controller Module
- Software Utility CD or Disks
- cPCI-6968/cPCI-6969 Expansion Module

If any of these items is missing or damaged, contact the dealer from whom you purchased the product. Save the shipping materials and carton in case you want to ship or store the product in the future.

2.2 Unpacking

Your serial communication module contains sensitive electronic components that can be easily damaged by static electricity.

The module should be done on a grounded anti-static mat. The operator should be wearing an anti-static wristband, grounded at the same point as the anti-static mat.

Inspect the module carton for obvious damage. Shipping and handling may cause damage to your module. Be sure there are no shipping and handling damages on the module before processing.

After opening the module carton, extract the system module and place it only on a grounded anti-static surface component side up.

Again inspect the module for damage. Press down on all the socket IC's to make sure that they are properly seated. Do this only with the module place on a firm flat surface.

Note: DO NOT APPLY POWER TO THE CARD IF IT HAS BEEN DAMAGED.

You are now ready to install your cPCI module.

2.3 Installation Procedure

1. Turn off your computer
2. Turn off all accessories (printer, modem, monitor, etc.) connected to computer.
3. Select a cPCI expansion slot.
4. Before handling the serial communication module, discharge any static buildup on your body by touching the metal case of the computer. Hold the edge and do not touch the components.
5. Position the board into the cPCI slot you selected.
6. Secure the card in place of the system.

2.4 Hardware Configuration

The serial communication module has plug and play component, the card can requests memory usage (I/O port locations) of the card which is assigned by system BIOS. The address assignment is done on a board-by-board basis for all serial communication cards in the system. The jumper JP1 for the serial communication card is used for the system to recognize the first or second card of the same model in the system if there are two cards of the same on board.

2.5 Software Installation

2.5.1 Windows NT Installation

Once Windows NT system has been started, login using an account with administrative right.

1. Start the [Control Panel] applet by double clicking the icon in the [Program Managers] main group
2. In the [Control Panel] applet, double click [Network] icon to bring up the Network Control Panel Applet (NCPA).
3. Within the NCPA, select the [Add Adaptor] button, a list of possible adaptors should be displayed. Go to the end of this list and select <Other> requires disk from manufacturer.
4. When prompted for the path, specify the drive and directory where the NCPA can find the new driver for the card you install.

We may specify as follow:

A: \Nt4

5. Now, you can follow the configuration dialog boxes to install the driver.
6. In the default condition, the TTY port is given name from "COM3". User can specify the start "COM" port number in installation procedure.
7. We can install up to two same type serial communication cards in one NT system.

8. When you need to install two same type serial communication cards in one NT system, you must confirm to let one card' s jumper JP1 is ON while the other card' s jumper JP1 is OFF.
9. The card with jumper ON will have low COM port number. The card with jumper OFF will have higher COM port number follow the card with jumper ON.
10. If you install two same type serial communication cards with jumper ON or OFF simultaneously, we can not confirm that both cards will active properly.
11. If you install multiple cards in one NT system simultaneously, please confirm that the COM port number assigned do not overlap for different card. Or you may have improperly operation in your system.
12. For easy to maintain NT system' s COM port number, we suggest that you must set the jumper ON for the first card to be installed in NT system.
13. After you install the driver, you need to reboot your PC, then you can have more COM port available.
14. If you had installed our NT driver in your system before, you might remove this driver firstly, then you can install our new version driver. Or you might have some problem in your system.

2.5.2 UNIX/XENIX Installation

Under the UNIX/XENIX operation system, the serial communication card is an extra peripheral device. A device driver should be linked with the kernel to build a new kernel system. The serial communication system will work after the new kernel system is restarted.

The installation environment could be

1. IBM PC/AT X86 or other compatible machine.
2. UNIX system V release 3 releases 4 or SCO XENIX system V.
3. Under the above environment, all the link kit packages should be installed completely.

Files in the installation diskette have

1. /etc/PCIIOP/README
2. /etc/PCIIOP/build
3. /etc/PCIIOP/d1
4. /etc/PCIIOP/OBJ/P960F.O (For different card, replace P960F to

- relative name)
5. /etc/PCIIOP/DRIVER/Driver.x
 6. /etc/PCIIOP/DRIVER/Driver.u
 7. /etc/PCIIOP/DRIVER/Driver.u1
 8. /etc/PCIIOP/DRIVER/Driver.s
 9. /etc/PCIIOP/DRIVER/Driver.e
 - 10./etc/PCIIOP/DRIVER/Driver.e2
 - 11./etc/PCIIOP/DRIVER/Driver.e6
 - 12./etc/PCIIOP/etty
 - 13./etc/PCIIOP/om (This is the utility file for interface card operation condition monitor.)

What may be happened while installing:

1. Link kit packages have not been installed completely. (Install like kit completely.)
2. Can not boot the system due to low voltage. (Use a higher wattage power supply.)

Installation Procedures:

1. Login as a super user.
Login: root
Password:
/etc/custom
2. Choose the "Add a Supported Product" item, and then select "Install one or more packages" item.
How many cards can be installed?
Enter 1-2 or enter q to quit:
3. Please strike the numeric key 1 to 2 to continue the installation procedure.
Updating system configuration.
Making terminal device 100%.
Editing terminal definitions 100%.
Installing serial communication card driver.
You must create a new kernel to effect the driver change to your specified.
Do you wish to create a new kernel now? (y/n)
4. Now strike "n" key if you want to quit this procedure, or "y" key to continue the procedure.

5. From this procedure, the screen message and installation procedure will be different for XENIX and UNIX system.

In XENIX system:

Re-linking the kernel.

Kernel with driver modifications is in /usr/sys/conf/xenix

Do you want this kernel to reboot by default? (y/n) y

The new kernel is installed in /xenix.

Reboot your system to activate it.

#

In UNIX system:

The UNIX operating system will now be rebuild.

This will take a few minutes. Please wait.

The UNIX Kernel has been rebuilt

6. At sight of the above message, you can assure that you have finished your installation. At this moment, please shutdown the operating system and reboot it.

When there is no “custom” command in system, you can use the “tar” command.

1. Login as a super user.

Login: root

Password:

cd/

2. Extract all the files on the diskette by “tar” command.

```
tar xvf /dev/fd0135ds18
```

3. # cd /etc/PCIOP

4. # ./build

5. System will display following main menu on the screen:

Global View Intelligent Input/Output Processor

Installation:

1. Install PCIOP Driver

2. Remove PCIOP Driver

Select an option or enter q to quit: 1

6. Choose the "Add a Supported Product" item, and then select "Install one or more packages" item.
How many cards can be installed?
Enter 1-2 or enter q to quit:
7. Please strike the numeric key 1 to 2 to continue the installation procedure.
Updating system configuration.
Making terminal device 100%.
Editing terminal definitions 100%.
Installing serial communication card driver.
You must create a new kernel to effect the driver change to your specified.
Do you wish to create a new kernel now? (y/n)
8. Now strike "n" key if you want to quit this procedure, or "y" key to continue the procedure.
9. From this procedure, the screen message and installation procedure will be different for XENIX and UNIX system.

In XENIX system:

Re-linking the kernel.

Kernel with driver modifications is in /usr/sys/conf/xenix

Do you want this kernel to reboot by default? (y/n) y

The new kernel is installed in /xenix.

Reboot your system to activate it.

#

In UNIX system:

The UNIX operating system will now be rebuilt.

This will take a few minutes. Please wait.

The UNIX Kernel has been rebuilt

10. At sight of the above message, you can assure that you have finished your installation. At this moment, please shutdown the operating system and reboot it.

After restarting the new kernel, the IO processor will indicate as follows:

```
PCIOP: unit = 0 type = P960F bus = 0 dev = 0 fun = 0 map = 0xF4000000 :  
8KB
```

```
Downloading PCIOP card(s) .....
```

PCIIOp: unit = 0 type = P960F dram = 0MB ports = 8 (F641)

Here:

“unit =” denotes the installation card number in the system.

“type =” denotes the PCIIOp interface card type.

“map =” denotes the mapping address and memory space of dual port RAM, should be assigned by PCI bus.

“dram =” denotes the PCIIOp interface card’ s built-in memory space.

“ports =” denotes the number of ports, which should be octal of the number of expansion boxes.

When the above message appears and the active LED in cPCI-6968/cPCI-6969 expansion module light on, it means the communication interface controller has been installed successfully.

If the message of “map =” or “ports =” is not correct (including no message) or any of the LED in cPCI-6968/cPCI-6969 module is not on, you should proceed error detecting and correcting procedure as follows:

1. Shutdown the operating system, turn off the power.
2. If you can not boot the system successfully, please check the voltage level. If the voltage level is too low to boot the system, check the number of controller module and cPCI-6968/cPCI-6969 module.
3. Insure the controller interface module has been inserted correctly at system expansion slot. Insure the rear connector has been connected correctly between controller module and cPCI-6968/cPCI-6969 module.
4. Check the memory mapping setting and insure that it does not conflict with other device’ s memory mapping.
5. Turn on the power and reboot the operating system. If you can insure the device driver is well installed, it is not necessary to re-execute the software installation procedure. Otherwise you may need to re-execute the software installation procedure.
6. If the message does not indicate correctly, please repeat previous procedure or contact your supplier.

Definitions of serial port device:

Card No.	Device Name
1	tty6??
2	tty7??

Card number 1 is the card with JP1 jumper on.

cPCI-6968/cPCI-6969 No.	Device Name
1	tty?1?
2	tty?2?
3	tty?3?
4	tty?4?
5	tty?5?
6	tty?6?
7	tty?7?
8	tty?8?

Port No.	Device Name (non Modem)	Device Name (Modem)
1	tty??a	tty??A
2	tty??b	tty??B
3	tty??c	tty??C
4	tty??d	tty??D
5	tty??e	tty??E
6	tty??f	tty??F
7	tty??g	tty??G
8	tty??h	tty??H

3

Expansion/Isolation Module User Guide

3.1 Introduction

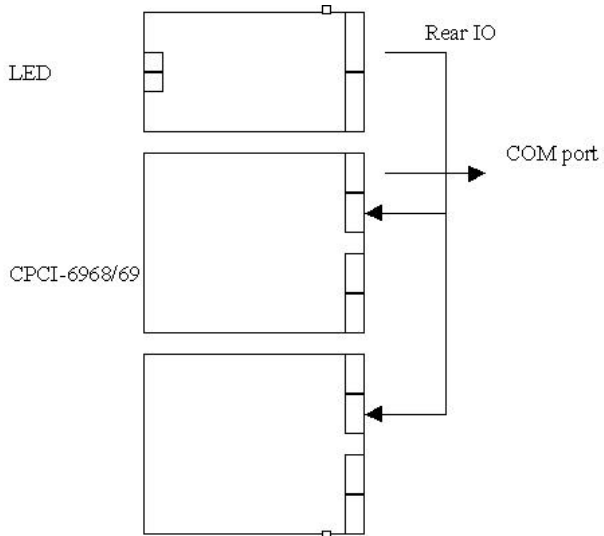

A serial interface controller has the configuration shown as above block diagram. An APU is the kernel of a serial communication controller system. It can manage up to 8 pieces of cPCI-6968/cPCI-6969 module. The APU communicates with the MPU via dual port RAM and processes the data transfer between MPU and I/O devices.

cPCI-6969 module:

Features

- 6U CompactPCI form factor
- Modular structure, easy to setup and expand ports
- Expand from 8 to 64 serial ports in just 5 second
- REAR IO connector for port extension and communication
- LED indicator for self-diagnosis and network status

Specification

- 6U CompactPCI form factor
- 8 ports RS-232
- Max. 8 modules for one cPCI-3938 controller module
- Controller: FIFO type ST16C554
- Baud Rate: Each port can be configured to 110 ~ 230,400 bps
- Connector: REAR IO connector, REAR IO connector for port extension
- Operating temperature: 0 ~ 60 °C
- Storage temperature: -10 ~ 70 °C
- Humidity: 5% ~ 95%, non-condensing
- Power consumption: +5V @ 1200mA typical 6U CompactPCI form factor

cPCI-6968 module:

Features

- 6U CompactPCI form factor
- Modular structure, easy to setup and expand ports
- Expand from 8 to 64 serial ports in just 5 second
- REAR IO connector for port extension and communication
- LED indicator for self-diagnosis and network status

Specification

- 6U CompactPCI form factor
- 8 ports RS-232/422/485 selectable
- Isolation Voltage: 500 VDC
- Max. 8 modules 64 ports for one cPCI-3938 controller module
- Controller: FIFO type ST16C554
- Baud Rate: Each port can be configured to 110 ~ 230,400 bps
- Connector: REAR IO connector, REAR IO connector for port extension
- Operating temperature: 0 ~ 60 °C
- Storage temperature: -10 ~ 70 °C
- Humidity: 5% ~ 95%, non-condensing
- Power consumption: +5V @ 1400mA typical

For cPCI-6968, each port has two bits DIP switch to set for RS-232, RS-422 or RS-485 interface. In RS-485 mode, we had auto data direction function to maintain no local echo condition, but user may still need to maintain just only one port to output data, so RS-485 mode must be used in half-duplex transmission environment. For full-duplex transmission environment, user may need to use RS-422 mode.

RS-422 interface application note:

RS-422 interface is used for point to point connection or multi-drop application. We can use RTS & CTS signal to have hardware handshake between two devices. But user may need to keep in mind that we can only let one driver output signal to be active in one time, or you may let the driver IC be burnt.

Even though we had put one 120 ohm terminator resistor in each input signal pair, user may need to remove this terminator resistor for proper operation.

Due to proper operation, user may not let one cable left in unconnected condition. Because the crosstalk problem may let one transmit data signal to be coupled to receive data input. This may lead wrong process in some application environment.

Because RS-422 interface do not use DTR/DSR/DCD signal, user may not use DTR/DSR handshake and DCD signal checking function in its application, these signals are in inactive condition for RS-422 interface.

RS-485 interface application note:

RS-485 interface is used for multi-drop half-duplex application. Because we had put auto-direction capability in the box, user may not use RTS signal to control the data direction. So it is no use for RTS/CTS signal in RS-485 interface. Because we had put one 120 ohm terminator resistor in RXD input signal pair, user may need to remove this terminator resistor for proper operation.

Due to proper operation, user may not let one cable left in unconnected condition. Because the crosstalk problem may let one transmit data signal to be coupled to receive data input. This may lead wrong process in some application environment.

Because RS-485 interface do not use RTS/CTS/DTR/DSR/DCD signal, user may not use RTS/CTS or DTR/DSR handshake and DCD signal checking function in its application, these signals are in inactive condition for RS-422 interface.

3.2 Pin Definition / DIP Switch Setting

The pin definition for cPCI-6968 J4 connector.

25	GND						GND	P4 / J4 CONNECTOR	
24	GND	LAD0	SG	LAD1	SG	LAD2	GND		
23	GND	LAD3	SG	LAD4	SG	LAD5	GND		
22	GND	LAD6	SG	LAD7	SG	LA0	GND		
21	GND	LA1	SG	LA2	SG	LA3	GND		
20	GND	LA4	SG	LA5	SG	LA6	GND		
19	GND	LA7	SG	LA8	SG	LCE#	GND		
18	GND	LWR#	SG	LRD#	SG	LRESET	GND		
17	GND	LINT1	SG	LINT2	SG	LINT3	GND		
16	GND	LINT4	5V	5V	+12V	-12V	GND		
15	GND	5V	5V	5V	+12V	-12V	GND		
12-14	GND	KEY AREA							GND
11	GND						GND		
10	GND	CD0	SG	CD1	SG	CD2	GND		
9	GND	CD3	SG	CD4	SG	CD5	GND		
8	GND	CD6	SG	CD7	SG	CA0	GND		
7	GND	CA1	SG	CA2	SG	CA3	GND		
6	GND	CA4	SG	CA5	SG	CA6	GND		
5	GND	CA7	SG	CA8	SG	CCE#	GND		
4	GND	CWR#	SG	CRD#	SG	CRESET	GND		
3	GND	CINT1	SG	CINT2	SG	CINT3	GND		
2	GND	CINT4	5V	5V	+12V	-12V	GND		
1	GND	5V	5V	5V	+12V	-12V	GND		
Pin	Z	A	B	C	D	E	F		

The pin definition for cPCI-6968 J5 connector.

22	GND	GA4	GA3	GA2	GA1	GA0	GND	P5 / J5 C O N N E C T O R
21	GND						GND	
20	GND	RXD+ 8	RXD- 8	SG	TXD+ 8	TXD- 8	GND	
19	GND	TX 8	RX 8	SG	N+ 8	N- 8	GND	
18	GND	RXD+ 7	RXD- 7	SG	TXD+ 7	TXD- 7	GND	
17	GND	TX 7	RX 7	SG	N+ 7	N- 7	GND	
16	GND						GND	
15	GND	RXD+ 6	RXD- 6	SG	TXD+ 6	TXD- 6	GND	
14	GND	TX 6	RX 6	SG	N+ 6	N- 6	GND	
13	GND	RXD+ 5	RXD- 5	SG	TXD+ 5	TXD- 5	GND	
12	GND	TX 5	RX 5	SG	N+ 5	N- 5	GND	
11	GND						GND	
10	GND	RXD+ 4	RXD- 4	SG	TXD+ 4	TXD- 4	GND	
9	GND	TX 4	RX 4	SG	N+ 4	N- 4	GND	
8	GND	RXD+ 3	RXD- 3	SG	TXD+ 3	TXD- 3	GND	
7	GND	TX 3	RX 3	SG	N+ 3	N- 3	GND	
6	GND						GND	
5	GND	RXD+ 2	RXD- 2	SG	TXD+ 2	TXD- 2	GND	
4	GND	TX 2	RX 2	SG	N+ 2	N- 2	GND	
3	GND	RXD+ 1	RXD- 1	SG	TXD+ 1	TXD- 1	GND	
2	GND	TX 1	RX 1	SG	N+ 1	N- 1	GND	
1	GND						GND	
Pin	Z	A	B	C	D	E	F	

RS-232

TX: Transmit Data

RX: Receive Data

RS-422

TXD+: Transmit Data Positive

TXD-: Transmit Data Negative

RXD+: Receive Data Positive

RXD-: Receive Data

Negative

RS-485

N+: Data Signal Positive

N-: Data Signal Negative

Switch Setting

Port	A	B	C	D	E	F	G	H
Switch	SW2	SW2	SW2	SW2	SW1	SW1	SW1	SW1
Bit	1,2	3,4	5,6	7,8	1,2	3,4	5,6	7,8

Mode switch setting

DIP Switch Bit 1,3,5,7	DIP Switch Bit 2,4,6,8	Interface Mode
ON	ON	RS-232
ON	OFF	RS-232
OFF	ON	RS-422
OFF	OFF	RS-485

		SW2				SW1			
RS232	ON	1	3	5	7	1	3	5	7
422/485	OFF	A	B	C	D	E	F	G	H

		SW2				SW1			
RS422	ON	2	4	6	8	2	4	6	8
RS485	OFF	A	B	C	D	E	F	G	H

Asynchronous Communication Backplane C6869B Connector Assignment
for cPCI-6968

Module No.	Port No.	Connector
1	A-D (1-4)	CON1
1	E-H (5-8)	CON2
2	A-D (1-4)	CON3
2	E-H (5-8)	CON4
3	A-D (1-4)	CON5
3	E-H (5-8)	CON6
4	A-D (1-4)	CON7
4	E-H (5-8)	CON8
5	A-D (1-4)	CON9
5	E-H (5-8)	CON10
6	A-D (1-4)	CON11
6	E-H (5-8)	CON12
7	A-D (1-4)	CON13
7	E-H (5-8)	CON14

Pin Assignment of 40 Pin Pin-header for cPCI-6968

Pin No.	Signal Name	Pin No.	Signal Name
1	TX ^① / TX ^⑤	2	RX ^① / RX ^⑤
3	SG ^① / SG ^⑤	4	N+ ^① / N+ ^⑤
5	N- ^① / N- ^⑤	6	RXD+ ^① / RXD+ ^⑤
7	RXD- ^① / RXD- ^⑤	8	SG ^① / SG ^⑤
9	TXD+ ^① / TXD+ ^⑤	10	TXD- ^① / TXD- ^⑤
11	TX ^② / TX ^⑥	12	RX ^② / RX ^⑥
13	SG ^② / SG ^⑥	14	N+ ^② / N+ ^⑥
15	N- ^② / N- ^⑥	16	RXD+ ^② / RXD+ ^⑥
17	RXD- ^② / RXD- ^⑥	18	SG ^② / SG ^⑥
19	TXD+ ^② / TXD+ ^⑥	20	TXD- ^② / TXD- ^⑥
21	TX ^③ / TX ^⑦	22	RX ^③ / RX ^⑦
23	SG ^③ / SG ^⑦	24	N+ ^③ / N+ ^⑦
25	N- ^③ / N- ^⑦	26	RXD+ ^③ / RXD+ ^⑦
27	RXD- ^③ / RXD- ^⑦	28	SG ^③ / SG ^⑦
29	TXD+ ^③ / TXD+ ^⑦	30	TXD- ^③ / TXD- ^⑦
31	TX ^④ / TX ^⑧	32	RX ^④ / RX ^⑧
33	SG ^④ / SG ^⑧	34	N+ ^④ / N+ ^⑧
35	N- ^④ / N- ^⑧	36	RXD+ ^④ / RXD+ ^⑧
37	RXD- ^④ / RXD- ^⑧	38	SG ^④ / SG ^⑧
39	TXD+ ^④ / TXD+ ^⑧	40	TXD- ^④ / TXD- ^⑧

The pin definition cPCI-6969 J4 connector.

25	GND						GND	P4 / J4 CONNECTOR	
24	GND	LAD0	SG	LAD1	SG	LAD2	GND		
23	GND	LAD3	SG	LAD4	SG	LAD5	GND		
22	GND	LAD6	SG	LAD7	SG	LA0	GND		
21	GND	LA1	SG	LA2	SG	LA3	GND		
20	GND	LA4	SG	LA5	SG	LA6	GND		
19	GND	LA7	SG	LA8	SG	LCE#	GND		
18	GND	LWR#	SG	LRD#	SG	LRESET	GND		
17	GND	LINT1	SG	LINT2	SG	LINT3	GND		
16	GND	LINT4	5V	5V	+12V	-12V	GND		
15	GND	5V	5V	5V	+12V	-12V	GND		
12-14	GND	KEY AREA							GND
11	GND						GND		
10	GND	CD0	SG	CD1	SG	CD2	GND		
9	GND	CD3	SG	CD4	SG	CD5	GND		
8	GND	CD6	SG	CD7	SG	CA0	GND		
7	GND	CA1	SG	CA2	SG	CA3	GND		
6	GND	CA4	SG	CA5	SG	CA6	GND		
5	GND	CA7	SG	CA8	SG	CCE#	GND		
4	GND	CWR#	SG	CRD#	SG	CRESET	GND		
3	GND	CINT1	SG	CINT2	SG	CINT3	GND		
2	GND	CINT4	5V	5V	+12V	-12V	GND		
1	GND	5V	5V	5V	+12V	-12V	GND		
Pin	Z	A	B	C	D	E	F		

The pin definition for cPCI-6969 J5 connector.

22	GND	GA4	GA3	GA2	GA1	GA0	GND	P5 / J5 CONNECTOR
21	GND						GND	
20	GND	DSR ^③	DCD ^③	DTR ^③	RTS ^③	CTS ^③	GND	
19	GND	FG ^③	TX ^③	RX ^③	SG ^③		GND	
18	GND	FG ^⑦	TX ^⑦	RX ^⑦	SG ^⑦		GND	
17	GND	DSR ^⑦	DCD ^⑦	DTR ^⑦	RTS ^⑦	CTS ^⑦	GND	
16	GND						GND	
15	GND	DSR ^⑥	DCD ^⑥	DTR ^⑥	RTS ^⑥	CTS ^⑥	GND	
14	GND	FG ^⑥	TX ^⑥	RX ^⑥	SG ^⑥		GND	
13	GND	FG ^⑤	TX ^⑤	RX ^⑤	SG ^⑤		GND	
12	GND	DSR ^⑤	DCD ^⑤	DTR ^⑤	RTS ^⑤	CTS ^⑤	GND	
11	GND						GND	
10	GND	DSR ^④	DCD ^④	DTR ^④	RTS ^④	CTS ^④	GND	
9	GND	FG ^④	TX ^④	RX ^④	SG ^④		GND	
8	GND	FG ^③	TX ^③	RX ^③	SG ^③		GND	
7	GND	DSR ^③	DCD ^③	DTR ^③	RTS ^③	CTS ^③	GND	
6	GND						GND	
5	GND	DSR ^②	DCD ^②	DTR ^②	RTS ^②	CTS ^②	GND	
4	GND	FG ^②	TX ^②	RX ^②	SG ^②		GND	
3	GND	FG ^①	TX ^①	RX ^①	SG ^①		GND	
2	GND	DSR ^①	DCD ^①	DTR ^①	RTS ^①	CTS ^①	GND	
1	GND						GND	
Pin	Z	A	B	C	D	E	F	

RS-232

FG: Frame Ground
Data

RTS:Request to Send
Ready

SG: Signal Ground
Terminal Ready

TX: Transmit Data

CTS:Clear to Send

DCD:Data Carrier Detect

RX: Receive

DSR:Data Set

DTR:Data

Asynchronous Communication Backplane C6869B Connector Assignment
for cPCI-6969

Module No.	Port No.	Connector
1	A-D (1-4)	CON1
1	E-H (5-8)	CON2
2	A-D (1-4)	CON3
2	E-H (5-8)	CON4
3	A-D (1-4)	CON5
3	E-H (5-8)	CON6
4	A-D (1-4)	CON7
4	E-H (5-8)	CON8
5	A-D (1-4)	CON9
5	E-H (5-8)	CON10
6	A-D (1-4)	CON11
6	E-H (5-8)	CON12
7	A-D (1-4)	CON13
7	E-H (5-8)	CON14

Pin Assignment of 40 Pin Pin-header for cPCI-6969

Pin No.	Signal Name	Pin No.	Signal Name
1	DSR ¹ / DSR ⁵	2	DCD ¹ / DCD ⁵
3	DTR ¹ / DTR ⁵	4	RTS ¹ / RTS ⁵
5	CTS ¹ / CTS ⁵	6	FG ¹ / FG ⁵
7	TX ¹ / TX ⁵	8	RX ¹ / RX ⁵
9	SG ¹ / SG ⁵	10	--
11	FG ² / FG ⁶	12	TX ² / TX ⁶
13	RX ² / RX ⁶	14	SG ² / SG ⁶
15	--	16	DSR ² / DSR ⁶
17	DCD ² / DCD ⁶	18	DTR ² / DTR ⁶
19	RTS ² / RTS ⁶	20	CTS ² / CTS ⁶
21	DSR ³ / DSR ⁷	22	DCD ³ / DCD ⁷
23	DTR ³ / DTR ⁷	24	RTS ³ / RTS ⁷
25	CTS ³ / CTS ⁷	26	FG ³ / FG ⁷
27	TX ³ / TX ⁷	28	RX ³ / RX ⁷
29	SG ³ / SG ⁷	30	--
31	FG ⁴ / FG ⁸	32	TX ⁴ / TX ⁸
33	RX ⁴ / RX ⁸	34	SG ⁴ / SG ⁸
35	--	36	DSR ⁴ / DSR ⁸
37	DCD ⁴ / DCD ⁸	38	DTR ⁴ / DTR ⁸
39	RTS ⁴ / RTS ⁸	40	CTS ⁴ / CTS ⁸

LED indicator for cPCI-6969/68

	OFF	Red ON	Green ON
Active	No Power or Controller module	Receive	Transmit
A	No Operation	Receive	Transmit
B	No Operation	Receive	Transmit
C	No Operation	Receive	Transmit
D	No Operation	Receive	Transmit
E	No Operation	Receive	Transmit
F	No Operation	Receive	Transmit
G	No Operation	Receive	Transmit
H	No Operation	Receive	Transmit

Notice: If the DIP is set to RS-422 or RS-485 mode for cPCI-6968 while there is no loading connected, while power is on, there might be an uncertain state on the bus which maybe recognize as receive mode and the RED LED will turn on. The module will filter this condition and there is no really receive operation.

Product Warranty/Service

Seller warrants that equipment furnished will be free from defects in material and workmanship for a period of one year from the confirmed date of purchase of the original buyer and that upon written notice of any such defect, Seller will, at its option, repair or replace the defective item under the terms of this warranty, subject to the provisions and specific exclusions listed herein.

This warranty shall not apply to equipment that has been previously repaired or altered outside our plant in any way as to, in the judgment of the manufacturer, affect its reliability. Nor will it apply if the equipment has been used in a manner exceeding its specifications or if the serial number has been removed.

Seller does not assume any liability for consequential damages as a result from our product uses, and in any event our liability shall not exceed the original selling price of the equipment.

The equipment warranty shall constitute the sole and exclusive remedy of any Buyer of Seller equipment and the sole and exclusive liability of the Seller, its successors or assigns, in connection with equipment purchased and in lieu of all other warranties expressed implied or statutory, including, but not limited to, any implied warranty of merchant ability or fitness and all other obligations or liabilities of seller, its successors or assigns.

The equipment must be returned postage-prepaid. Package it securely and insure it. You will be charged for parts and labor if you lack proof of date of purchase, or if the warranty period is expired.