

**NuIPC**  
**cPCI-3700A series**  
3U CompactPCI All-in-one  
Pentium-III/Celeron CPU Module  
**User's Guide**



Recycled Paper



© Copyright 2001 ADLINK Technology Inc.

All Rights Reserved.

Manual Rev. 1.00: May 16, 2001

Part No. 50-11212-100

The information in this document is subject to change without prior notice in order to improve reliability, design and function and does not represent a commitment on the part of the manufacturer.

In no event will the manufacturer be liable for direct, indirect, special, incidental, or consequential damages arising out of the use or inability to use the product or documentation, even if advised of the possibility of such damages.

This document contains proprietary information protected by copyright. All rights are reserved. No part of this manual may be reproduced by any mechanical, electronic, or other means in any form without prior written permission of the manufacturer.

### **Trademarks**

NuIPC is a registered trademark of ADLINK Technology Inc.

Other product names mentioned herein are used for identification purposes only and may be trademarks and/or registered trademarks of their respective companies.

# Getting service from ADLINK

?Customer Satisfaction is always the most important thing for ADLINK Technology Inc. If you need any help or service, please contact us and get it.

<b>ADLINK Technology Inc.</b>			
Web Site	http://www.adlink.comtw http://www.adlinktechnology.com		
Sales & Service	service@adlink.comtw		
Technical Support	NuDAQ	nudaq@adlink.comtw	
	NuDAM	nudam@adlink.comtw	
	NuIPC	nuipc@adlink.comtw	
	NuPRO	nupro@adlink.comtw	
TEL	+886-2-82265877	FAX	+886-2-82265717
Address	9F, No. 166, Jian Yi Road, Chunggho City, Taipei, 235 Taiwan, R.O.C.		

?Please inform or FAX us of your detailed information for a prompt, satisfactory and constant service.

<b>Detailed Company Information</b>			
Company/Organization			
Contact Person			
E-mail Address			
Address			
Country			
TEL		FAX	
Web Site			
<b>Questions</b>			
Product Model			
Environment to Use	<input type="checkbox"/> OS _____		
	<input type="checkbox"/> Compute _____		
	<input type="checkbox"/> M/B :		<input type="checkbox"/> CPU :
	<input type="checkbox"/> Chipset :		<input type="checkbox"/> BIOS :
	<input type="checkbox"/> Video Card :		
	<input type="checkbox"/> Network Interface Card :		
	<input type="checkbox"/> Other :		
Challenge Description			
Suggestions to ADLINK			

# Table of Contents

<b>Chapter 1 Introduction</b> .....	<b>1</b>
1.1 Checklist.....	1
1.2 Description.....	2
1.3 Features.....	3
1.4 Specifications of the module.....	4
<b>Chapter 2 Hardware Installation</b> .....	<b>8</b>
2.1 Jumpers on the cPCI-3700A.....	9
2.2 Connectors on the cPCI-3700A.....	12
2.2.1 <i>The cPCI-3700A Module</i> .....	13
2.2.2 <i>The cPCI-R3700A Rear I/O Transition Module</i> .....	14
2.2.3 <i>VGA Connector</i> .....	15
2.2.4 <i>USB Connectors</i> .....	15
2.2.5 <i>Ethernet (RJ-45) Connector</i> .....	15
2.2.6 <i>Mini D-Sub Parallel Port Connector</i> .....	15
2.2.7 <i>Parallel Port Connector (Via Transition Cable)</i> .....	16
2.2.8 <i>PS/2 Mouse Connector</i> .....	16
2.2.9 <i>PS/2 Keyboard Connector</i> .....	16
2.2.10 <i>CPU Fan Power Connector</i> .....	16
2.2.11 <i>COM1 Serial Ports (RS-232 Only)</i> .....	17
2.2.12 <i>CompactPCI Connectors</i> .....	17
2.2.13 <i>LCD Pin Assignments on cPCI-R3700A</i> .....	19
2.2.14 <i>COM2 Serial Ports (RS-232/422/485, DB-9)</i> .....	20
2.2.15 <i>COM2 Serial Ports (RS-232/422/485, Pin Headers)</i> .....	20
2.3 CPU Installation.....	21
2.4 Memory Installation.....	21
2.5 FDD Removal and Installation.....	22
2.6 HDD Removal and Installation.....	23
<b>Chapter 3 Getting Start</b> .....	<b>24</b>
3.1 Using SCSI CD-ROM with cPCI SCSI interface.....	24
<b>Chapter 4 Driver Installation</b> .....	<b>26</b>
4.1 VGA Drivers Installation.....	28
4.1.1 <i>Driver Installation on Windows 2000</i> .....	28

4.1.2	<i>Driver Installation on Windows 98</i> .....	29
4.1.3	<i>Driver Installation on Windows NT</i> .....	30
4.2	LAN Drivers Installation.....	31
4.2.1	<i>Software and Drivers Support</i> .....	31
4.2.2	<i>Driver Installation on Windows 2000</i> .....	31
4.2.3	<i>Driver Installation on Windows 98</i> .....	33
4.2.4	<i>Driver Installation on Windows NT</i> .....	34
<b>Chapter 5 Watchdog and Utilities .....</b>		<b>35</b>
5.1	Watchdog Timer Configuration.....	35
5.1.1	<i>WDT Programming</i> .....	36
5.1.2	<i>How to Test the WDT?</i> .....	36
5.2	Hardware Doctor Utility .....	37
5.3	Intel Preboot Execution Environment (PXE).....	38
<b>Product Warranty/Service.....</b>		<b>39</b>

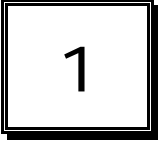

# Introduction

This manual is designed to give you information on the cPCI-3700A CPU module. The topics covered in this chapter are as follows:

- Checklist
- Descriptions
- Features
- Specifications

---

## 1.1 Checklist

There are several standard configurations available for cPCI-3700A series module. Please check your configurations with your dealer and check that your package is complete and contains the items below. If you discover damaged or missing items, please contact with your dealer.

- The cPCI-3700A module (May be equipped with different speed or capacity of CPU, RAM, HDD. Those items may vary according to the different configuration request)
- The cPCI-R3700A rear I/O transition module for cPCI-3700A
- The mini D-Sub to DB25 female parallel port transition cable
- This User's Manual
- ADLINK CD

---

**Note:** The package of cPCI-3700A OEM version (non-standard configuration, functionality or package) may vary according to the different configuration request.

---

---

## 1.2 Description

The cPCI-3700A series are Pentium-III/Celeron processor module for 3U CompactPCI form factor. The module is based on the Intel 440BX chipset and is fully designed for harsh industrial environment.

The cPCI-3700A is with 3U CompactPCI form factor, we provide two versions of cPCI-3700A:

- cPCI-3700A: The standard cPCI-3700A with 3-slot (12TE/HP) width, shipped with hard disk drive and separable floppy disk drive
- cPCI-3700A-2S: The cPCI-3700A with 2-slot (8TE/HP) width, shipped with hard disk drive (but without floppy disk drive)



---

## 1.3 Features

- PICMG 2.0 CompactPCI Specification R2.1 Compliant
- Standard 3U form factor
- Design for Socket-370 Pentium-III/Celeron CPU
- Supports up to FC-PGA Pentium-III CPU at 850MHz or Celeron CPU at 733MHz
- One 144-pin SO-DIMM socket supports up to 256MB RAM with optional ECC support
- Build-in housing for 2.5" low profile HDD
- Separable slim type floppy drive module
- Two on-board EIDE 44-pin connector
- Build-in two USB ports, two serial ports, one parallel port
- Separate PS/2 type keyboard and mouse connectors
- Supports 7 bus-master PCI devices on CompactPCI bus peripheral slots
- On-board high performance AGP 2x VGA/LCD display output by SMI SM721 controller
- VGA resolution up to 1600x1200 (driver dependent)
- LCD resolution up to 1024x768 for 24-bit RGB-TFT LCD
- Supports dual-display and simultaneous display for both VGA and LCD output
- On-board 10/100Mb Ethernet port by Intel 82559 controller
- Supports Intel pre-boot execution environment (PXE) for remote boot
- One DOC socket supports up to 144MB DiskOnChip
- 3 or 2 slots width configurations are available for customized applications

---

## 1.4 Specifications of the module

### General CompactPCI Features

- PCI Rev.2.1 compliant
- PICMG 2.0 CompactPCI Rev. 2.1 compliant.

### CPU/Cache

- Intel Socket-370 FC-PGA Pentium III with 256KB on-die L2 cache @ full-core speed & 100MHz FSB
- Intel Socket-370 FC-PGA Celeron with 128KB on-die L2 cache @ full-core speed & 66MHz FSB
- Front side bus (FSB) frequency: 66/100MHz

### Chipset

- Intel 440BX AGPset
- Intel 82443BX and 82371EB(PIIX4E)

### BIOS

- Award PnP BIOS with 2Mb Flash ROM
- BIOS write protection, provide anti-virus capability
- Customized power-on screen (for OEM project)
- DMI BIOS Support: Desktop Management Interface (DMI) allows users to download system hardware-level information such as CPU type, CPU speed, internal/external frequencies and memory size.
- Green Function: Power management via BIOS, activated through mouse/keyboard movement

### Host Memory

- One 144-pin SO-DIMM socket, Max. 256MB un-buffered SDRAM module
- Optional ECC capability support (available for big quantity OEM project)

### IDE Ports

- Bus Master IDE controller, two 44-pin EIDE interfaces support up to four IDE devices
- Support PIO Mode 3/4 or Ultra DMA/33 IDE devices

## **USB Interface**

- Two USB ports on front faceplate.
- USB Specification Rev. 1.1. compliant
- Individual over-current protection

## **On Board Supper I/O**

- Winbond W83977EF
- One high-speed bi-directional SPP/EPP/ECP parallel port with ESD protection to 4KV and downstream device protection to 30V
- One floppy interface, support slim type floppy drive
- Two 16C550 UARTs compatible RS-232 COM ports with ESD protection to 2KV, COM1 on front faceplate, selectable RS-232/422/485 COM2 port on rear I/O transition module

## **Watchdog Timer**

- Programmable I/O port 3F0h and 3F1h to configure watchdog timer, programmable timer 1~255 seconds or 1~255 minutes
- Bundled easy-programming library for DOS, Windows 95, 98, NT

## **Hardware Monitoring**

- Winbond W83782D, monitoring CPU temperature, CPU fan, system temperature and DC Voltages

## **On-board VGA/LCD Display**

- AGP 2x VGA/LCD controller SMI Lynx3DM SM721, with build-in 4M VRAM (8M VRAM available for big quantity OEM project)
- VGA display on front faceplate, 24-bit RGB-TFT LCD connector on rear I/O transition module
- High performance, 128-bit, single clock cycle 2D drawing engine
- High performance, power managed 3D acceleration engine
- AGP 2x, ACPI, VESA DPMS and VESA DDC 2b compliant
- Supports up to 1280x1024 VGA display resolution with 24-bit true color, non-interlaced
- Supports up to 1600x1200 VGA display resolution with 16-bit high color, non-interlaced under WindowsNT
- Dual display and simultaneous display for VGA and LCD
- RAMDAC Latch-up protection
- Driver supporting: Windows95/98/ME/NT/2000, Linux, OS/2

### **On-board Ethernet**

- Intel 82559 high performance Ethernet controller
- IEEE 802.3 10Base-T/100Base-TX compatible
- IEEE 802.3u auto-negotiation support
- IEEE 802.3x 100Base-TX flow control support
- Supports Intel pre-boot execution environment (PXE) for remote boot of WindowsNT/2000
- Driver supporting: DOS, Novell, Windows95/98/ME/NT/2000, Linux, SCO Unix, Sun Solaris, QNX

### **PCI Bus Mastering Support**

- Supports up to 7 PCI bus mastering devices on CompactPCI bus peripheral slots

### **Flash Disk Supporting**

- Support Flash2000™ flash disk (from 8MB to 1GB) on build-in housing of 2.5" low profile HDD via 44-pin EIDE port
- One DOC socket supports up to 144MB DiskOnChip

### **Form Factor**

- Standard 3U CompactPCI
- 12TE/HP wide, incl. separable slim type floppy or 8TE/HP wide without floppy module

### **Front Panel LEDs and Switch**

- Power status (green)
- IDE activity (green)
- Ethernet port: 10/100Mb (amber), link/activity (green)
- Flush tact switch for system reset

### **Environment**

- Operating temperature: 0 to 60°C
- Storage temperature: -20 to 80°C
- Humidity: 5% to 95% non-condensed
- Shock: 15G peak-to-peak, 11ms duration, non-operation
- Vibration:
  - ✓ Non-operation: 1.88Grms, 5-500Hz, each axis
  - ✓ Operation: 0.5Grms, 5-500Hz, each axis, with 2.5" HDD

## Safety Certificate and Test

- CE, FCC
- HALT (temperature and vibration stress)

## Power Consumption

Configurations	+5V	+3.3V	+12V	-12V
Pentium III 600 MHz 64MB	4.0A	3.0A	150mA	0A
Pentium III 850 MHz 256MB	5.7A	3.6A	150mA	0A

---

**Note:** The above values are the measured power consumption for SBC with CPU, CPU cooler and RAM only; the CPU is running under 100% loading. The powers for all the other peripheral devices such as keyboard, mouse, add-on cards, HDD, or CD-ROM are not included.

---

## Peripheral Connectivity

I/O	Front		Rear	
	Faceplate	Board	Faceplate	Board
Serial Port (COM1)	Y (DB-9)	---	---	---
Serial Port (COM2, RS-232/422/485)	---	---	Y (J2, DB-9)	Y (10-pin)
Parallel Port (Mini D-Sub 26-pin)	Y	---	---	---
PS/2 Keyboard	Y	---	---	---
PS/2 Mouse	Y	---	---	---
Floppy	---	Y (FL-26)	---	---
Ultra DMA 33 IDE 1	---	Y (44-pin)	---	---
Ultra DMA 33 IDE 2	---	Y (44-pin)	---	---
USB A/B	Y	---	---	---
10/100Mb Ethernet Port	Y (RJ-45)	---	---	---
VGA	Y (DB-15)	---	---	---
24-bit TFT LCD	---	---	---	Y (J2, 44-pin)
LEDs	Y	---	---	---
Reset button	Y	---	---	---

# 2

## Hardware Installation

This chapter provides information on how to use the jumpers and connectors on the cPCI-3700A in order to set up a workable system. We also describe how to add on components such as memory, CPU, HDD and FDD on to the modules. The topics covered are:

- Jumpers on the cPCI-3700A
- Connectors on the cPCI-3700A
- CPU Installation
- Memory Installation
- FDD Remove and Installation
- HDD Remove and Installation

---

## 2.1 Jumpers on the cPCI-3700A

The jumpers on the cPCI-3700A allow you to configure your CPU module according to the needs of your applications. If you have doubts about the best jumper configuration for your needs, contact your dealer or sales representative. The cPCI-3700A module is constructed from the main board (which has CPU Socket on it) and the daughter board (which brings out serial port and parallel port). There are jumpers on both main board and daughter boards. The following table lists the jumper connectors on cPCI-3700A and their respective functions.

Board	Connector	Description
Main board	JP2	Flat Panel Voltage Selection
Daughter board	JP1	Clear CMOS content
Daughter board	JP2, JP3, JP4	Select COM2 Type

---

**Note 1:** There is no jumper for DiskOnChip BIOS expansion address selection. The default expansion address for DOC is located from D8000h to DFFFFh.

**Note 2:** There is no jumper for front side bus (FSB) and CPU speed selection. The FSB and CPU speed are set by auto-detection.

---

Jumpers and connectors map of cPCI-3700A main board (PCB name: cPCI-3700A).

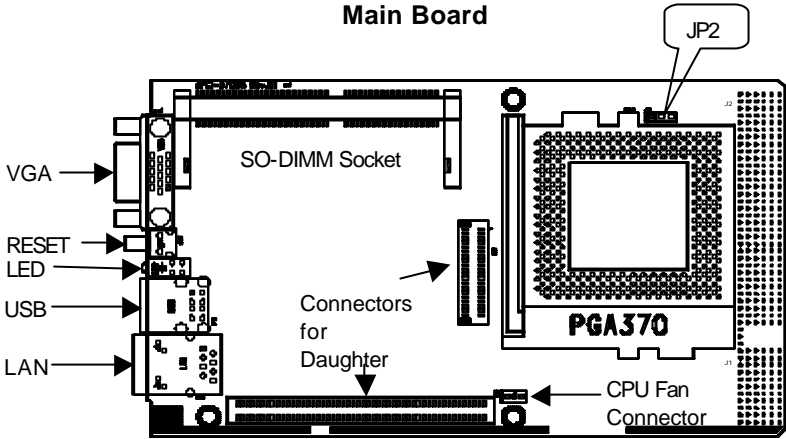

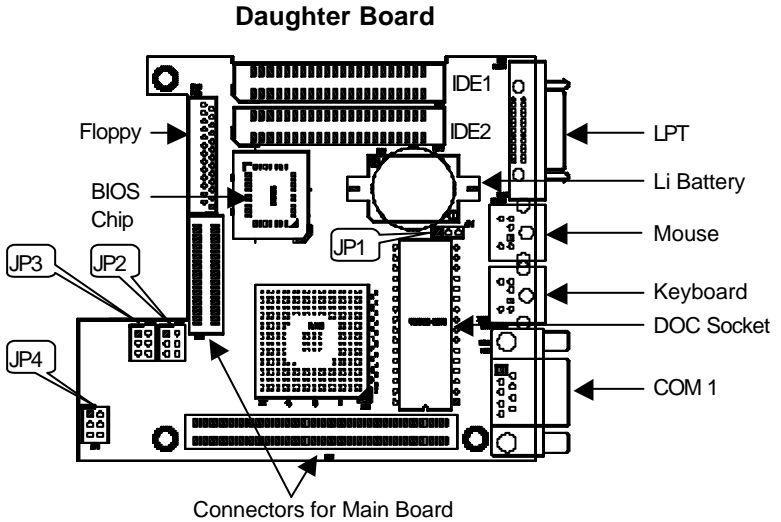

Jumpers and connectors map of cPCI-3700A daughter board (PCB name: cPCI-3700X).







### JP2 on Main Board: Flat Panel Voltage Selection

JP2 (main board)	Setting	Function
	Pin 1-2 Short/Closed	Flat Panel VDD = +3.3V
	Pin 2-3 Short/Closed	Flat Panel VDD = +5V

### JP1 on Daughter Board: Clear CMOS Content

JP1 (daughter board)	Setting	Function
	Pin 1-2 Short/Closed	Clear CMOS Content
	Pin 2-3 Short/Closed	Normal Operation

### JP2~4 on Daughter Board: Select COM2 Type

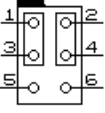
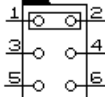
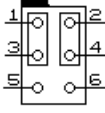
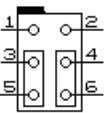
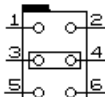
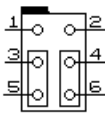
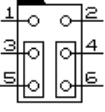
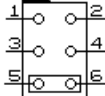
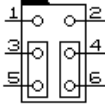
Type	JP2	JP3	JP4
<b>RS-232</b>	 1-3 2-4	 1-2	 1-3 2-4
<b>RS-422</b>	 3-5 4-6	 3-4	 3-5 4-6
<b>RS-485</b>	 3-5 4-6	 5-6	 3-5 4-6

---

## 2.2 Connectors on the cPCI-3700A

The connectors on the cPCI-3700A allows you to connect devices such as keyboard, mouse, printer and internal floppy disk drives, hard disk drives, etc. The following table lists the connectors on cPCI-3700A and their respective functions.

2.2.1	<i>The cPCI-3700A Module</i> .....	13
2.2.2	<i>The cPCI-R3700A Rear I/O Transition Module</i> .....	14
2.2.3	<i>VGA Connector</i> .....	15
2.2.4	<i>USB Connectors</i> .....	15
2.2.5	<i>Ethernet (RJ-45) Connector</i> .....	15
2.2.6	<i>Mini D-Sub Parallel Port Connector</i> .....	15
2.2.7	<i>Parallel Port Connector (Via Transition Cable)</i> .....	16
2.2.8	<i>PS/2 Mouse Connector</i> .....	16
2.2.9	<i>PS/2 Keyboard Connector</i> .....	16
2.2.10	<i>CPU Fan Power Connector</i> .....	16
2.2.11	<i>COM1 Serial Ports (RS-232 Only)</i> .....	17
2.2.12	<i>CompactPCI Connectors</i> .....	17
2.2.13	<i>LCD Pin Assignments on cPCI-R3700A</i> .....	19
2.2.14	<i>COM2 Serial Ports (RS-232/422/485, DB-9)</i> .....	20
2.2.15	<i>COM2 Serial Ports (RS-232/422/485, Pin Headers)</i> .....	20

### 2.2.1 The cPCI-3700A Module

The following picture shows the cPCI-3700A module. The front panel connectors are VGA, USB, Ethernet, parallel port (mini D-Sub), mouse, keyboard and COM1 port.

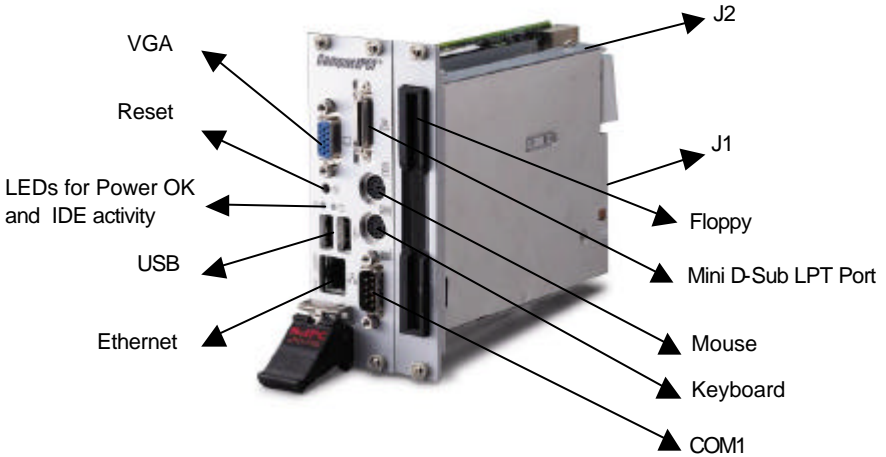

## 2.2.2 The cPCI-R3700A Rear I/O Transition Module

The following picture shows the cPCI-R3700A rear I/O transition module. The rear faceplate DB-9 connector is COM2 port. LCD pin-headers connector and COM2 pin-headers connector are available on the board.

---

**Note:** Do NOT connect devices to the COM2 pin-headers on board and DB-9 on rear faceplate at the same time. This may cause system damages.

---

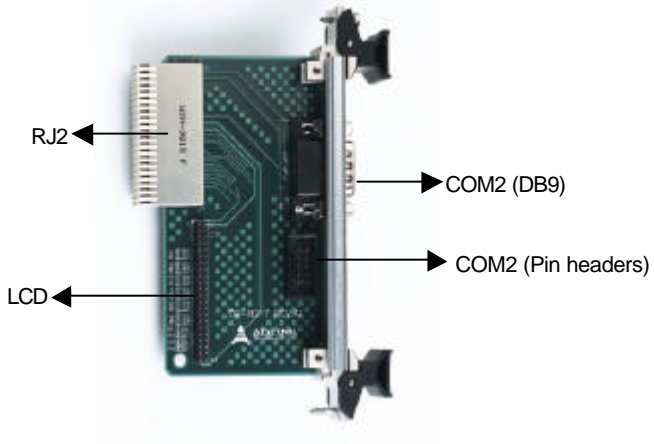

### 2.2.3 VGA Connector

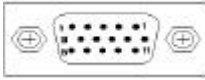

Signal Name	Pin	Pin	Signal Name
Red	1	2	Green
Blue	3	4	N.C.
GND	5	6	GND
GND	7	8	GND
N.C.	9	10	GND
N.C.	11	12	N.C.
HSYNC	13	14	VSYNC
NC	15		

### 2.2.4 USB Connectors

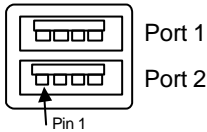

Pin #	Signal Name
1	Vcc
2	USB-
3	USB+
4	Ground

### 2.2.5 Ethernet (RJ-45) Connector

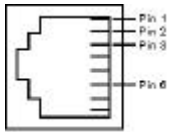

Pin #	Signal Name
1	TD+
2	TD-
3	RD+
6	RD-

### 2.2.6 Mini D-Sub Parallel Port Connector

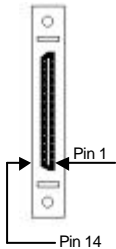

Signal Name	Pin #	Pin #	Signal Name
Line printer strobe	1	14	AutoFeed
PD0, parallel data 0	2	15	Error
PD1, parallel data 1	3	16	Initialize
PD2, parallel data 2	4	17	Select
PD3, parallel data 3	5	18	Ground
PD4, parallel data 4	6	19	Ground
PD5, parallel data 5	7	20	Ground
PD6, parallel data 6	8	21	Ground
PD7, parallel data 7	9	22	Ground
ACK, acknowledge	10	23	Ground
Busy	11	24	Ground
Paper empty	12	25	Ground
Select	13	26	N/C

## 2.2.7 Parallel Port Connector (Via Transition Cable)

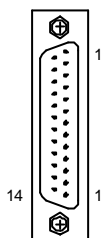

Signal Name	Pin #	Pin #	Signal Name
Line printer strobe	1	14	AutoFeed
PD0, parallel data 0	2	15	Error
PD1, parallel data 1	3	16	Initialize
PD2, parallel data 2	4	17	Select
PD3, parallel data 3	5	18	Ground
PD4, parallel data 4	6	19	Ground
PD5, parallel data 5	7	20	Ground
PD6, parallel data 6	8	21	Ground
PD7, parallel data 7	9	22	Ground
ACK, acknowledge	10	23	Ground
Busy	11	24	Ground
Paper empty	12	25	Ground
Select	13	N/A	N/A

## 2.2.8 PS/2 Mouse Connector

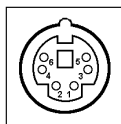

Pin #	Signal Name
1	Mouse data
2	N.C.
3	GND
4	5V
5	Mouse Clock
6	N.C.

## 2.2.9 PS/2 Keyboard Connector

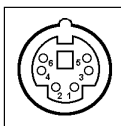

Pin #	Signal Name
1	Keyboard data
2	N.C.
3	GND
4	5V
5	Keyboard clock
6	N.C.

## 2.2.10 CPU Fan Power Connector



Pin #	Signal Name
1	Ground
2	+12V
3	Rotation

### 2.2.11 COM1 Serial Ports (RS-232 Only)

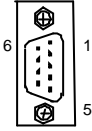

Pin #	Signal Name
1	DCD, Data carrier detect
2	RXD, Receive data
3	TXD, Transmit data
4	DTR, Data terminal ready
5	GND, ground
6	DSR, Data set ready
7	RTS, Request to send
8	CTS, Clear to send
9	RI, Ring indicator

### 2.2.12 CompactPCI Connectors

- J1 Pin Assignments of cPCI-3700A (support 32-bit system slot)

Pin	Z	A	B	C	D	E	F
25	GND	+5V	REQ64#	ENUM#	+3.3V	+5V	GND
24	GND	AD[1]	+5V	NC	AD[0]	ACK64#	GND
23	GND	+3.3V	AD[4]	AD[3]	+5V	AD[2]	GND
22	GND	AD[7]	GND	+3.3V	AD[6]	AD[5]	GND
21	GND	+3.3V	AD[9]	AD[8]	GND	C/BE[0]#	GND
20	GND	AD[12]	GND	NC	AD[11]	AD[10]	GND
19	GND	+3.3V	AD[15]	AD[14]	GND	AD[13]	GND
18	GND	SERR#	GND	+3.3V	PAR	C/BE[1]#	GND
17	GND	+3.3V	SMSCL	SMSDA	GND	PERR#	GND
16	GND	DEVSEL#	GND	NC	STOP#	LOCK#	GND
15	GND	+3.3V	FRAME#	IRDY#	GND	TRDY#	GND
12-14	KEY						
11	GND	AD[18]	AD[17]	AD[16]	GND	C/BE[2]#	GND
10	GND	AD[21]	GND	+3.3V	AD[20]	AD[19]	GND
9	GND	C/BE[3]#	GND	AD[23]	GND	AD[22]	GND
8	GND	AD[26]	GND	NC	AD[25]	AD[24]	GND
7	GND	AD[30]	AD[29]	AD[28]	GND	AD[27]	GND
6	GND	REQ7#	GND	+3.3V	CLK7	AD[31]	GND
5	GND	NC	NC	PCIRST#	GND	GNT7#	GND
4	GND	NC	NC	NC	NC	SIRQ	GND
3	GND	INTA#	INTB#	INTC#	+5V	INTD#	GND
2	GND	TCK	+5V	TMS	TDO	TDI	GND
1	GND	+5V	-12V	TRST#	+12V	+5V	GND
Pin	Z	A	B	C	D	E	F

- J2 Pin Assignments of cPCI-3700A and cPCI-R3700A (support 32-bit system slot)

Pin	Z	A	B	C	D	E	F
22	GND	NC	NC	NC	NC	NC	GND
21	GND	CLK6	GND	RTS#	CTS2#	RXD2#	GND
20	GND	CLK5	GND	RI2#	GND	TXD2#	GND
19	GND	GND	GND	NC	NC	NC	GND
18	GND	NC	NC	NC	GND	NC	GND
17	GND	NC	GND	PRST#	REQ6#	GNT6#	GND
16	GND	NC	NC	DEG#	GND	NC	GND
15	GND	NC	GND	FAL#	REQ5#	GNT5#	GND
14	GND	FPVDD	FPSCCLK	ENFPVDD	GND	DSR2#	GND
13	GND	FPVDD	GND	NC	DTR2#	DCD2#	GND
12	GND	+12VFP	N/C	FP/FVSYNC	GND	M/DE	GND
11	GND	LP	GND	NC	FPD17	VBIASEN	GND
10	GND	FPD11	FPD13	FPD15	GND	ENBKL	GND
9	GND	FPD9	GND	NC	FPD10	FPD23	GND
8	GND	FPD7	FPD14	FPD20	GND	FPD21	GND
7	GND	FPD4	GND	NC	FPD8	FPD19	GND
6	GND	FPD2	FPD16	FPD22	GND	FPD5	GND
5	GND	FPD0	FPD12	NC	FPD6	FPD3	GND
4	GND	NC	NC	FPD18	GND	FPD1	GND
3	GND	CLK4	GND	GNT3#	REQ4#	GNT4#	GND
2	GND	CLK2	CLK3	SYSEN#	GNT2#	REQ3#	GND
1	GND	CLK1	GND	REQ1#	GNT1#	REQ2#	GND
Pin	Z	A	B	C	D	E	F



### 2.2.13 LCD Pin Assignments on cPCI-R3700A

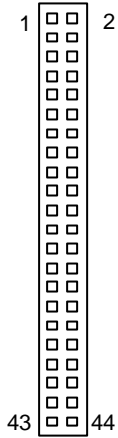

Signal Name	Pin #	Pin #	Signal Name
+12VFP	1	2	+12VFP
GND	3	4	GND
FPVDD	5	6	FPVDD
ENFPVEE	7	8	GND
FPD0	9	10	FPD1
FPD2	11	12	FPD3
FPD4	13	14	FPD5
FPD6	15	16	FPD7
FPD8	17	18	FPD9
FPD10	19	20	FPD11
FPD12	21	22	FPD13
FPD14	23	24	FPD15
FPD16	25	26	FPD17
FPD18	27	28	FPD19
FPD20	29	30	FPD21
FPD22	31	32	FPD23
GND	33	34	GND
SHFCLK	35	36	FLM
MDE	37	38	LP
GND	39	40	ENBKL
GND	41	42	NC
ENFPVDD	43	44	FPVDD

---

**Note 1:** The +12V power sources, which are designed to provide power to back light inverter, is protected by 1.1A resetable fuse.

**Note 2:** LCD VEE is the power source for LCD logic circuit. The power of 3.3V or 5V voltage is selectable by JP2 on main board. The power ON/OFF is controlled by ENFPVEE signal. The power is with over-current protection by resetable fuse.

**Note 3:** LCD VDD power source, which is controlled by the ENFPVDD signal, comes from +3.3V. The power is with over-current protection by resetable fuse. This power is for providing the LCD bias voltage.

---

### 2.2.14 COM2 Serial Ports (RS-232/422/485, DB-9)

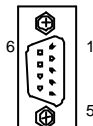

Pin #	RS-232	RS-422	RS-485
1	DCD, Data carrier detect	TX-	DATA-
2	RXD, Receive data	TX+	DATA+
3	TXD, Transmit data	RX+	NC
4	DTR, Data terminal ready	RX-	NC
5	GND, ground	GND	GND
6	DSR, Data set ready	NC	NC
7	RTS, Request to send	NC	NC
8	CTS, Clear to send	NC	NC
9	RI, Ring indicator	NC	NC

### 2.2.15 COM2 Serial Ports (RS-232/422/485, Pin Headers)

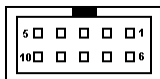

Pin #	RS-232	RS-422	RS-485
1	DCD, Data carrier detect	TX-	DATA-
2	RXD, Receive data	TX+	DATA+
3	TXD, Transmit data	RX+	NC
4	DTR, Data terminal ready	RX-	NC
5	GND, ground	GND	GND
6	DSR, Data set ready	NC	NC
7	RTS, Request to send	NC	NC
8	CTS, Clear to send	NC	NC
9	RI, Ring indicator	NC	NC
10	NC	NC	NC

---

## 2.3 CPU Installation

The cPCI-3700A CPU module supports Intel Socket 370 FC-PGA Pentium-III processors of 100 MHz front side bus (FSB) or FC-PGA Celeron processors of 66 MHz FSB. Users need to install high efficient CPU cooler to guarantee the system stability. The modules with standard configurations are equipped with CPU and cooler, and the type or speed is upon request. For OEM customers, please follow up the following note to install the CPU.

The Socket 370 connector uses a standard FC-PGA socket connector. To install the CPU, insert it to the socket by aligning the notch of the Socket 370 CPU with the one of the FC-PGA socket.

---

**Note:** Ensure that the CPU heat sink and the CPU top surface are in tightly contact to avoid CPU overheating problem that would cause your system to hang or be unstable. The CPU heat sink and fan should be installed tightly too. The FAN with speed sensor is recommend.

---

---

## 2.4 Memory Installation

The cPCI-3700A CPU module supports one SO-DIMM socket for a maximum total memory of 256MB with optional ECC support. The memory type must be SDRAM. The modules with standard configurations are equipped with memory, and the size is upon request. The memory module can come with size of 32MB, 64MB, 128MB or 256 MB (chip size should be 16Mx8) SDRAM.

---

## 2.5 FDD Removal and Installation

In cPCI-3700A user can install one 3.5 inches slim type FDD. Three slots version of cPCI-3700A module comes with FDD module installed.

### ***FDD Removal***

To remove the FDD module, please follow this procedure

- Disconnect the flex cable connector of the FDD
- Remove the 4 screws on two side of FDD
- Remove the FDD carefully
- Remove the FDD housing frame
- Remove the flex cable from the connector on daughter board

### ***FDD Installation***

To install the FDD, please follow this procedure

- Connect the flex cable one end with the connector on daughter board. Leave the other end floating at the moment
- Install the FDD housing frame
- Install the FDD on the FDD housing frame with the screw holes align with those on the housing
- Screw the FDD with 4 screws
- Connect the flex cable to FDD

---

## 2.6 HDD Removal and Installation

In cPCI-3700A, user can install one 2.5 inches HDD or flash disk. The modules with standard configurations are equipped with 2.5 inches HDD, and the capacity of the HDD is upon request.

### ***HDD Removal for cPCI-3700A***

To remove the HDD, please follow this procedure

- Remove the FDD
- Remove whole FDD drive bay and the 3<sup>rd</sup>-slot front panel by removing 3 or 4 screws
- Remove the 4 copper stand-off between FDD drive bay and HDD drive holder plate
- Dis-connect the HDD cable (44-pin)
- Remove the 3 screws on the top of HDD drive holder plate, remove the 2 screws on the front panel, then you can remove the whole HDD with the drive holder plate
- Remove the 4 screws which lock the HDD on the drive holder plate. Then the HDD is de-attached

### ***HDD Installation for cPCI-3700A***

- Lock the HDD on the drive holder plate. Please note the orientation of the HDD. The HDD's pin #1 must match the location of IDE connector pin #1
- Install the HDD with the drive holder plate on the module. Lock the 2 screws on the front panel, and 3 screws on the drive holder plate.
- Connect the 44-pin HDD cable (44-pin), check if pin #1 of the IDE connector, cable and the HDD are matched
- Screw 4 copper stand-off on HDD drive holder plate
- Put FDD drive bay with the 3<sup>rd</sup>-slot front panel, screw the FDD drive bay with the copper stand-off on HDD drive holder plate
- Put FDD on drive bay and screw the four screws

# 3

## Getting Start

This chapter describe how to get start to install the OS into the 3U CompactPCI platform for the cPCI-3700A CPU module. Due to most of the current OS must be installed from the CD-ROM drive, user will encounter a challenge to connect the IDE port on the CPU module to the external CD-ROM. We provide the following method to help you to connect the cPCI-3700A to the CD-ROM.

---

### 3.1 Using SCSI CD-ROM with cPCI SCSI interface

If you have bootable SCSI CD-ROM drive and 3U CompactPCI SCSI interface (e.g. cPCI-8212, the SCSI interface module from ADLink), you can easily install desired OS or application programs. If you want to boot-up system from a bootable SCSI CD-ROM, please follow the instruction below (assume your SCSI CD-ROM drive is external):

1. Power-off the system.
2. Insert 3U CompactPCI SCSI interface into one available slot. Please make sure the SCSI interface support CD-ROM boot-up.
3. Use the proper cable to connect the CD-ROM drive and SCSI interface module firmly. Check the termination of the SCSI bus is set or installed properly. Please also make sure the CD-ROM drive supports boot-up function.
4. Check the SCSI ID of the CD-ROM drive is unique on the SCSI bus.
5. Connect the power cord to the CD-ROM drive.

6. Power-on the external CD-ROM drive and put the bootable CD that contains the desired OS into drive.
7. Power-on the system and press <DEL> key to enter the BIOS setup utility. Then, set the boot sequence beginning from SCSI in BIOS features setup. Save and exit the BIOS setup utility.
8. After power-on-self-test (POST), go into SCSI adaptor utility (usually press Ctrl-C or F2, please refer to the user's manual of SCSI interface module.) Then, check the SCSI adaptor is bootable. Save and exit the SCSI adaptor utility.
9. The system will boot from the SCSI CD-ROM.

# 4

## Driver Installation

To install the drivers and utility for the cPCI-3700A, please refer the detail installation information from this Chapter. We provide the basic information in this manual, however, for more detail installation information, such as non-Windows OS installation, please refer the extensive explanation inside the ADLINK CD. We put the chip drivers in the following directories:

Chipset driver	\\CHIPDR\\Chipset\\440BX
VGA/AGP relative driver	\\CHIPDR\\VVGAS\\M721
LAN relative driver	\\CHIPDR\\VLAN\\100PDISK
Watchdog relative library	\\CHIPDR\\VWDT
Hardware Doctor Utility	\\Utility\\HWD\\Doctor\\I2C

In this users manual, the Bus-mastering IDE driver installation is not described because most of the Windows based OS will install those drivers automatically.

Due to the Windows NT is a none plug-and-play OS, we remind you some tips for installing the Windows NT here:

1. We suggest installing the LAN driver before installing any service pack.
2. We suggest installing the VGA/AGP driver after installing the service pack. Please make sure your service pack do support AGP, service pack 6 or higher is recommend.
3. Once your NT booting procedure is with warning, please check the Event Viewer to make sure what is the really problem. Once the



Windows NT is with strange phenomenal which can not be solved, we suggest to re-install the Windows NT service pack, then install the driver in different sequence again.

---

## 4.1 VGA Drivers Installation

This chapter describes VGA driver installation for the onboard VGA/LCD controller **SM721**. The relative drivers are in the following ADLINK CD directory: **X:\CHIPDRV\VGA\SM721**, where X: is the location of the CD-ROM drive. The VGA drivers for Windows 98/95, Windows NT and Windows 2000 are included.

### 4.1.1 Driver Installation on Windows 2000

The Windows 2000 may install the standard VGA driver. We recommend you to manually installed the most updated driver, which shipped with ADLINK CD to guarantee the compatibility. After installing the Windows 2000, please update the new drivers by the following procedures.

1. Boot Windows 2000, Click **Start**. Select **Settings** then double-click the **Control Panel**.
2. Double-click on the **System** icon, click **Hardware** tab, click **Device Manager** button.
3. Double-click either on the *Display Adapters* or *Other Devices* entry, Double-click the *Video Controller* or Silicon Motion Lynx3DM entry.
4. Click on the **Driver** tab, then click **Update Driver...** button.
5. An Upgrade Device Driver Wizard windows, click **NEXT>**.
6. Select *Display a list of ...* and click **NEXT**.
7. The next window may show a list of hardware type, then select **Display Adapters**, then click **OK**.
8. This window may show a list of VGA model numbers.
9. Insert ADLINK CD and click **Have Disk**.
10. **Browse** the SM721 driver in the following path: **X:\CHIPDRV\VGA\SM721\WIN2K**, highlight **smisetup.inf**, click **OPEN**, then click **NEXT>**.
11. Highlight the model: **Silicon Motion Lynx3DM**, then click **NEXT>**.

12. Click **NEXT>** button, The Windows 2000 may report Digital Signature Not Found, then click **Yes** to continue.
13. Click **Finish** button, then click **CLOSE** button.

#### 4.1.2 Driver Installation on Windows 98

The Windows 98 may install the standard VGA driver. We recommend you to manually installed the most updated driver, which shipped with ADLINK CD to guarantee the compatibility. After installing Windows 98, please update the new drivers by the following procedures.

1. Boot Windows 98, Click **Start**. Select **Settings** then double-click the **Control Panel**.
2. Double-click **System** icon, click on the **Device Manager** tab.
3. Double-click **Display Adapters** entry, select the **Standard PCI Graphics Adapter (VGA)** entry. Click the **Properties** button.
4. Click on the **Driver** button, then click **Update Driver...** button.
5. An Upgrade Device Driver Wizard windows, click **NEXT>**.
6. Select **Display a list of ...** and click **NEXT>**. The next window allows the user to specify a specific path. Insert the ADLINK CD and click **Have Disk**.
7. **Browse** the SM721 driver in the following path: **X:\CHIPDRV\VGA\SM721\WIN9X**, highlight **smi.inf**, click **OPEN**. Click **OK**.
8. Click **NEXT>** button, then the Wizard summary window appears.
9. Click **Finish** button, then restart the computer to active the new driver.

### 4.1.3 Driver Installation on Windows NT

The Windows NT may install the standard VGA driver while. We recommend you to manually installed the most updated driver, which shipped with ADLINK CD to guarantee the compatibility. After installing Windows NT, please update the new drivers by the following procedures.

1. From the **Control Panel**, double-click the **Display** icon.
2. Click the **Settings** tab, click **Display Type...**, click **Change...** button.
3. Insert ADLINK CD and click **Have Disk**.
4. **Browse** the SM721 driver in the following path: **X:\CHIPDRV\VGA\SM721WT40**, highlight **smisetup.inf**, click **OPEN**. Click **OK**.
5. A windows shows the **Display** is **Silicon Motion Lynx Family**, click **OK**, then click **Yes** to continue.
6. An **Installing Driver** window shows successful installing, click **OK** to continue.
7. Click **Close** button.
8. Click **Close** button, then restart the computer to active the new driver.

---

**Note:** After installing the VGA/AGP drivers, you may find the driver does not work. This may due to you do not install the NT service pack in advance. We suggest installing the NT service pack 4 or higher version to enable APG capability.

---

---

## 4.2 LAN Drivers Installation

This chapter describes LAN driver installation for the onboard Ethernet controller **Intel 82559**. The relative drivers are under the following ADLINK CD directory: **X:\CHIPDRV\LAN\100PDISK**, where X: is the location of the CD-ROM drive.

### 4.2.1 Software and Drivers Support

The 82559 drivers support the following OS or platforms:

- Windows 98, Windows 95, Windows 2000, Windows NT
- Novell Netware, DOS Setup for Novell NetWare DOS
- UNIX, OS2, Linux

All the above drivers are included in the ADLINK CD. In the following section, we will describe the driver installation for Windows 98, Windows 2000, and Windows NT. For the driver installation of the other OS, please refer the readme file inside the CD.

### 4.2.2 Driver Installation on Windows 2000

The Windows 2000 may install the LAN driver. We recommend you to manually installed the most updated LAN driver, which shipped with ADLINK CD to guarantee the compatibility. After installing the Windows 2000, please update the new drivers by the following procedures.

1. Boot Windows 2000, Click **Start**. Select **Settings** then double-click the **Control Panel**.
2. Double-click **System** icon, click **Hardware** tab, click **Device Manager** button.
3. Double-click Network Adapters entry, Double-click the Intel 8255x-based PCI Ethernet Adapter (10/100) entry.
4. Click **Driver** tab, then click **Update Driver...** button.
5. An Upgrade Device Driver Wizard windows, click **Next>**.
6. Select **Display a list of ...** and click **Next>**. The next window may show a list of hardware models.

7. Insert the CD and click **Have Disk**.
8. Browse the Intel 82559 driver in the following path: **X:\CHIPDRV\LAN\100PDISK**, highlight **oemsetup.inf**, click **Open**, then click **OK**.
9. Highlight the model: **Intel 8255x- based PCI Ethernet Adapter (10/100)**, then click **NEXT>**. An Update Driver Warning window may pop up, click **Yes** to continue.
10. Click **NEXT>** button, then the Wizard summary window appears.
11. Click **Finish** button, then click **CLOSE** button.

### 4.2.3 Driver Installation on Windows 98

The Windows 98 will install the LAN driver automatically. We recommend you to manually updated the LAN, which on the ADLINK CD to guarantee the compatibility. After installing Windows 98, please update the new drivers by the following procedures.

1. Boot Windows 98, Click **Start**. Select **Settings** then double-click the **Control Panel**.
2. Double-click on the **System** icon, click on the **Device Manager** tab.
3. Either Double-click on the **Network Adapters** entry, select the **Intel 8255x-based PCI Ethernet Adapter (10/100)** entry. Click the **Properties** button.
4. Click on the **Driver** button, then click **Update Driver...** button.
5. **Update Device Driver Wizard** starts, click **NEXT**.
6. Select **Display a list of ...** and click **NEXT**. The next window allows the user to specify a specific path. Insert the CD and click **Have Disk**.
7. Browse the Intel 82559 driver in the following path: **X:\CHIPDRV\LAN\100DISK**, highlight **net82557.inf**, click **OK**. The Update Wizard displays the message that it has found the driver. Click OK again to update the driver. Note: Windows 98 may ask you to insert the original Windows 98 CD to install the LAN protocols.
8. Click **NEXT** button, then the Wizard summary window appears.
9. Click **Finish** button, then restart the computer to active the new driver.

#### 4.2.4 Driver Installation on Windows NT

Before install the LAN driver on Windows NT, please copy the LAN driver in the CD to a floppy diskette. You have to put a new disk into drive A, then type the following batch command under DOS environment to copy the relative NT drivers.

**X:\CHIPDRV\LAN\100PDISK\Makedisk\Makedisk NT**

where X is the CD-ROM drive.

Windows NT may ask to install a LAN driver from its own library of drivers. We recommend you to manually update the LAN, which on the ADLINK CD to guarantee the compatibility. After installing Windows 98, please update the new drivers by the following procedures.

1. From the **Control Panel**, double-click the **Netwrok** icon, a Network Configuration window pop up, click **Yes**.
2. In Netwrok Setup Wizard, click **Next>**, click **Select From List...** button.
3. Insert LAN driver floppy diskette into A drive and click **Have Disk**.
4. In the dialog box of Insert Disk window, type in **A:**, Click **OK**.
5. A Select OEM Option window pop up, click **OK**, then click **Next>**.
6. Select necessary Network Protocols, click **Next>**.
7. Select necessary Network Services, click **Next>**.
8. Click **Next>** until Window NT Setup dialog box pop up. Type in **D:\V386** in the dialog box, then insert the original Windows NT CD, click **Continue**.
9. Then click **OK** until the setup completed.
10. Restart the computer to reboot.



# Watchdog and Utilities

---

## 5.1 Watchdog Timer Configuration

The Watch Dog Timer (WDT) can monitor the system's status. Once you give a value to WDT, the timer will begin to count down. To re-program a new value to WDT, or move keyboard can restart the WDT. If the system is idle or hang, it will reboot when the timer timeout.

The function of the watchdog timer is to reset the system automatically. It contains a one-second (or one-minute) resolution down counter (in CRF4 of logical device 8 of super I/O chip) and two Watchdog control registers (CRF2 and CRF3 of logical device 8).

We provides the WDT function call for easy use under DOS, Windows 95/98/2000, and Windows NT, please refer the information under ***X:CHIPDRV\WDT.***

### 5.1.1 WDT Programming

In order to simplify the programming code, we provide a sub function for the programmers to implement their software. For DOS, Windows 95 or 98 and Window NT, the sub function format is as follow:

```
out_port (int IOport_number, int Counter_value)
        IOport_number:0x3F0 -->W83977EF's configuration port.

        0x2E -->W83627HF's configuration port.
        Counter_value: 0 ~ 15300 (255 minutes)
```

(write a zero to disable the timer)

#### ***Under DOS, Windows 95 or 98***

Make a project program with `wdt.cpp` under Turbo C/C++.

#### ***Under Windows NT***

The library installation procedure:

- (1) run the setup program under NT environment.
- (2) reboot the system.

You can also write your own DLL by referring the DOS source we provide.

### 5.1.2 How to Test the WDT?

#### ***Under DOS, Windows 95 or 98***

Open a DOS command prompt and execute the following utility on the CD.

```
X: NuPRO\NuPRO800\WDT\test <n>

/* n = second value. This program can auto detect which Super
I/O chip you use. */
```

#### ***Under Windows NT***

Before you executing the program under NT, you must run the setup program under Windows NT in advance. Open a DOS command prompt window and execute the following command.

```
test977 <n> : n = second value. For W83977EF
```

---

## 5.2 Hardware Doctor Utility

This chapter introduces Hardware Doctor Utility that comes with the CPU board in conjunction with the onboard hardware monitoring function. The section describes the functions of the utility.

Hardware Doctor is a self-diagnostic system for PC and must be used with Winbond's W83781D/W83782D or W83627HF IC series products. It will protect PC Hardware by monitoring several critical items including Power Supply Voltage, CPU Fan speed, and CPU & System temperature. These items are important to the operation of system; errors may result in permanent hurt of PC. Once any item is out of its normal range, an obvious warning message will pop up and remind user to make a proper treatment.

The Hardware Doctor utility supports the Windows 98 and Windows NT. The software is stored on the ADLINK CD under the following directory: **X:\Utility\HWDoctor\2C\WIN98** and **X:\Utility\HWDoctor\2C\WNT4**. Please install the Hardware Doctor by executing the HI2C-98.exe or HI2C-NT.exe respectively under Windows 98 or Windows NT.

For detail user's manual, please refer the HWDoctor.PDF under the **X:\Utility\HWDoctor\WIN98\W8378X\**

---

## 5.3 Intel Preboot Execution Environment (PXE)

cPCI-3700A series support Intel Preboot Execution Environment (PXE) which provides the capability of boot-up from Ethernet even executing OS installation from Ethernet. There should be a DHCP server in the network with one or more servers running PXE service and MTFTP service. It could be a Windows NT or Windows 2000 server running DHCP, PXE and MTFTP service or a dedicated DHCP server with one or more additional server running PXE and MTFTP service. The section describes the major items for building up a network environment with PXE support.

1. Setup a DHCP server with PXE tag configuration.
2. Install the PXE and MTFTP services
3. Make boot image file on PXE server (that is the boot server).
4. Enable the PXE boot function on the client computer.

For more detailed information, please refer to pdkrel30.pdf under the directory ***X:\Utility\PXE\_PDK***.

## Product Warranty/Service

ADLINK warrants that equipment furnished will be free from defects in material and workmanship for a period of one year from the date of shipment. During the warranty period, we shall, at our option, either repair or replace any product that proves to be defective under normal operation.

This warranty shall not apply to equipment that has been previously repaired or altered outside our plant in any way as to, in the judgment of the manufacturer, affect its reliability. Nor will it apply if the equipment has been used in a manner exceeding its specifications or if the serial number has been removed.

ADLINK does not assume any liability for consequential damages as a result from our product uses, and in any event our liability shall not exceed the original selling price of the equipment. The remedies provided herein are the customer's sole and exclusive remedies. In no event shall ADLINK be liable for direct, indirect, special or consequential damages whether based on contract or any other legal theory.

The equipment must be returned postage-prepaid. Package it securely and insure it. You will be charged for parts and labor if the warranty period is expired or the product is proven to be misuse, abuse or unauthorized repair or modification.