

PC-HELPER

4ch 32Bit Up/Down
High-Speed Counter Card for CardBus

CNT32-4MT(CB)

User's Guide

CONTEC CO.,LTD.

Check Your Package

Thank you for purchasing the CONTEC product.

The product consists of the items listed below.

Check, with the following list, that your package is complete. If you discover damaged or missing items, contact your retailer.

Product Configuration List

- PC Card [CNT32-4MT(CB)] ...1
- First step guide ...1
- CD-ROM *1 [API-PAC(W32)] ...1

*1 The CD-ROM contains the driver software and User's Guide (this guide)

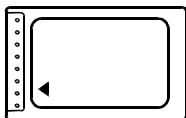

PC Card



First step guide



CD-ROM
[API-PAC(W32)]

Copyright

Copyright 2004 CONTEC CO., LTD. ALL RIGHTS RESERVED

No part of this document may be copied or reproduced in any form by any means without prior written consent of CONTEC CO., LTD.

CONTEC CO., LTD. makes no commitment to update or keep current the information contained in this document. The information in this document is subject to change without notice.

All relevant issues have been considered in the preparation of this document. Should you notice an omission or any questionable item in this document, please feel free to notify CONTEC CO., LTD.

Regardless of the foregoing statement, CONTEC assumes no responsibility for any errors that may appear in this document or for results obtained by the user as a result of using this product.

Trademarks

MS, Microsoft, Windows and Windows NT are trademarks of Microsoft Corporation. Other brand and product names are trademarks of their respective holder.

Table of Contents

Check Your Package	i
Copyright	ii
Trademarks	ii
Table of Contents	iii

1. BEFORE USING THE PRODUCT	1
------------------------------------	----------

About the PC Card	1
Features.....	1
Support Software.....	2
Cable & Connector (Option).....	2
Accessories (Option).....	2
Customer Support.....	3
Web Site	3
Limited Three-Years Warranty.....	3
How to Obtain Service.....	3
Liability	3
Safety Precautions	4
Safety Information	4
Handling Precautions.....	5
Environment	6
Inspection	6
Storage.....	6
Disposal	6

2. SETUP	7
-----------------	----------

What is Setup?.....	7
Using the PC Card under Windows Using the Driver Library API-PAC(W32)	7
Using the PC Card under Windows Using Software Other than the Driver Library API-PAC(W32).....	7
Using the PC Card under an OS Other than Windows	8
Step 1 Installing the Software.....	9
Starting the Install Program	9
Select the counter driver	10
Executing the Installation	11
Step 2 Setting the Hardware	12
Connecting the connection cable to the PC Card.....	12
Plugging the PC Card.....	13
Notes on use of two or more PC Cards[CNT32-4MT(CB)].....	14

Step 3 Installing the Hardware.....	15
Turning on the PC	15
Setting the Add New Hardware Wizard.....	15
Step 4 Initializing the Software.....	18
Invoking API-TOOL Configuration	18
Updating the Settings	18
Step 5 Checking Operations with the Diagnosis Program.....	19
What is the Diagnosis Program?.....	19
Check method 1: Checking the PC Card single-handedly (without external connection).....	19
Check method 2: Checking the PC Card single-handedly (with external connection).....	20
Check method 3: Checking the PC Card using an external device	21
Using the Diagnosis Program.....	22
Setup Troubleshooting.....	28
Symptoms and Actions.....	28
If your problem cannot be resolved	28

3.	EXTERNAL CONNECTION	29
-----------	----------------------------	-----------

Using the On-PC Card Connectors	29
Connecting a PC Card to a Connector	29
Connector Pin Assignment.....	30
How to Connect the Counter Input Signal.....	32
Example Connection for Counter Input Circuit	32
Example Connection with a Rotary Encoder	34
Example Connection with a Linear Scale.....	34
Connecting the control signal input/output.....	35
Connection of a control input.....	35
Control input circuit and its sample connection	35
Connection of a control output.....	38
Control output circuit and its sample connection.....	38

4.	FUNCTIONS	39
-----------	------------------	-----------

Types and Operations of Pulse Signals.....	39
Types of pulse signals	39
2-phase Input	39
Single-phase Input.....	40
Single-phase Input with Gate Control Attached.....	40
Multiplication of Count Input	41
Synchronous Clear.....	41
Asynchronous Clear	42
Phase-Z/CLR Input.....	42

Control of a counter	43
Counter start/Counter stop.....	43
Preset	44
Zero-clear	45
Register.....	45
Obtaining the count value	46
Obtaining the count value	46
Counter mode.....	46
Sampling mode.....	47
Totalizing/line receiver counter.....	48
Sampling function	49
Sampling function	49
Bus mastering.....	49
Interrupt (During bus mastering).....	49
Status, Count	50
Control of a sampling.....	51
Hardware event.....	52
Types of hardware events	52
Control input signal.....	53
Control output signal.....	54
Count match	55
Counter error	57
Sampling output signal	59
Status input	60
Pulse signal input states	60
Control input signal states	60
Error.....	60
Carry/Borrow	60
Count match	60
Other functions	61
Digital filter.....	61
Timer	61

5.	ABOUT SOFTWARE	63
-----------	-----------------------	-----------

Accessing the Help File	64
Using Sample Programs.....	65
Uninstalling the API Function Libraries	67
CD-ROM Directory Structure	68

6.	ABOUT HARDWARE	69
-----------	-----------------------	-----------

Hardware specification	69
Block Diagram.....	71



1. Before Using the Product

This chapter provides information you should know before using the product.

About the PC Card

The CNT32-4MT(CB) is a PC Card Standard -compliant CardBus TYPE II size PC Card that inputs and counts pulse signals from an external device.

The PC Card has four channels of 32-bit up/down counters, allowing external devices such as a rotary encoder and a linear scale to be connected. Given below are examples of using the PC Card for “detecting a position of the table of a machine tool” and “detecting a change in weight”.

The pulse signal inputting interface is unisolated LVTTTL-level input that can input pulse signals at high speed.

The application for this PC Card can transfer data between the PC Card and the PC at high speed using PCI bus mastering.

<Example >

- Detecting a position of the table of a machine tool

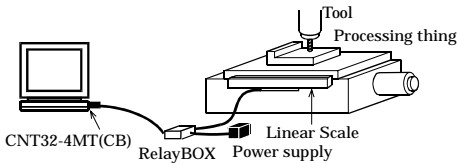

- Detecting a change in weight

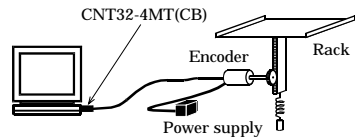

Features

- Can input two-phase and single-phase signals.
- Can input pulse signals up to 10MHz and can resolve phase differences as short as 25nsec.
- Can be converted to a differential input interface using the differential unit (CTP-4D) and connection cable (CNT-68M/50M) which are sold separately.
- One control signal input pin per channel.
- Can count values sampling at a maximum sampling rate of 20 MHz.
- Supporting bus mastering, enabling high-speed data transfer between the PC Card and the PC without intervention from the CPU.
- Can generate an interrupt, issuing an external signal, or presetting/zero-clearing the count value when it matches an arbitrary predefined value.

Support Software

You should use CONTEC support software according to your purpose and development environment.

Driver Library **API-PAC(W32)** (Bundled)

API-PAC(W32) is the library software that provides the commands for CONTEC hardware products in the form of Windows standard Win32 API functions (DLL). It makes it easy to create high-speed application software taking advantage of the CONTEC hardware using various programming languages that support Win32 API functions, such as Visual Basic and Visual C/C++.

It can also be used by the installed diagnosis program to check hardware operations.
CONTEC provides download services to supply the updated drivers and differential files.
For details, read Help on the bundled CD-ROM or visit the CONTEC's Web site.

< Operating environment >

OS	Windows XP, 2000, Me, 98, etc..
Adaptation language	Visual C/C++, Visual Basic, Delphi, Builder, etc..
Others	Each piece of library software requires 50 MB of free hard disk space.

Cable & Connector (Option)

Shielded cable for CardBus counter input card
: CNT-68M/50M (0.5m)

Cable with 68-Pin D-sub Connector at either Ends (Mold Type)
: PCB68PS-0.5P (0.5m)
: PCB68PS-1.5P (1.5m)

Shielded cable with single connector for 68-pin 0.8mm pitch connector
: PCA68PS-0.5P (0.5m)
: PCA68PS-1.5P (1.5m)

Accessories (Option)

Termination Panel with Differential Receivers for Counter Input	: CTP-4D *1
Screw Terminal (M3 x 50P)	: EPD-50A *1
Screw Terminal (M3 x 68)	: EPD-68A *2

*1 CNT-68M/50M optional cable is required separately.

*2 PCB68PS-0.5P or PCB68PS-1.5P optional cable is required separately.

* Check the CONTEC's Web site for more information on these options.

Customer Support

CONTEC provides the following support services for you to use CONTEC products more efficiently and comfortably.

Web Site

Japanese <http://www.contec.co.jp/>
English <http://www.contec.com/>
Chinese <http://www.contec.com.cn/>

Latest product information

CONTEC provides up-to-date information on products.

CONTEC also provides product manuals and various technical documents in the PDF.

Free download

You can download updated driver software and differential files as well as sample programs available in several languages.

Note! For product information

Contact your retailer if you have any technical question about a CONTEC product or need its price, delivery time, or estimate information.

Limited Three-Years Warranty

CONTEC Interface products are warranted by CONTEC CO., LTD. to be free from defects in material and workmanship for up to three years from the date of purchase by the original purchaser.

Repair will be free of charge only when this device is returned freight prepaid with a copy of the original invoice and a Return Merchandise Authorization to the distributor or the CONTEC group office, from which it was purchased.

This warranty is not applicable for scratches or normal wear, but only for the electronic circuitry and original products. The warranty is not applicable if the device has been tampered with or damaged through abuse, mistreatment, neglect, or unreasonable use, or if the original invoice is not included, in which case repairs will be considered beyond the warranty policy.

How to Obtain Service

For replacement or repair, return the device freight prepaid, with a copy of the original invoice. Please obtain a Return Merchandise Authorization number (RMA) from the CONTEC group office where you purchased before returning any product.

* No product will be accepted by CONTEC group without the RMA number.

Liability

The obligation of the warrantor is solely to repair or replace the product. In no event will the warrantor be liable for any incidental or consequential damages due to such defect or consequences that arise from inexperienced usage, misuse, or malfunction of this device.

Safety Precautions

Understand the following definitions and precautions to use the product safely.

Safety Information

This document provides safety information using the following symbols to prevent accidents resulting in injury or death and the destruction of equipment and resources. Understand the meanings of these labels to operate the equipment safely.

⚠ DANGER	DANGER indicates an imminently hazardous situation which, if not avoided, will result in death or serious injury.
⚠ WARNING	WARNING indicates a potentially hazardous situation which, if not avoided, could result in death or serious injury.
⚠ CAUTION	CAUTION indicates a potentially hazardous situation which, if not avoided, may result in minor or moderate injury or in property damage.

Handling Precautions

DANGER

Do not use the product where it is exposed to flammable or corrosive gas. Doing so may result in an explosion, fire, electric shock, or failure.

CAUTION

- Mount the PC Card in a PC Card Standard CardBus compatible PC Card slot.
 - Do not strike or bend the PC Card.
Otherwise, the PC Card may malfunction, overheat, cause a failure or breakage.
 - Do not plug or unplug any PC Card into or from the expansion slot with the PC powered.
Otherwise, the PC Card may malfunction, overheat, cause a failure.
Be sure to turn off the PC.
 - The specifications of this product are subject to change without notice for enhancement and quality improvement.
Even when using the product continuously, be sure to read the manual and understand the contents.
 - Do not modify the product. CONTEC will bear no responsibility for any problems, etc., resulting from modifying this product.
 - Regardless of the foregoing statements, CONTEC is not liable for any damages whatsoever (including damages for loss of business profits) arising out of the use or inability to use this CONTEC product or the information contained herein.
 - Power saving mode (standby mode) is not supported. Setup the PC so that the power is always turned on.
-

Environment

Use this product in the following environment. If used in an unauthorized environment, the PC card may overheat, malfunction, or cause a failure.

Operating temperature

0 to 50°C

Operating humidity

10 to 90%RH (No condensation)

Corrosive gases

None

Floating dust particles

Not to be excessive

Inspection

Inspect the product periodically as follows to use it safely.

- Check for any dirt or corrosion on the metal-plated terminals in the connector.

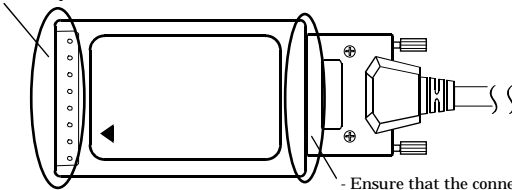

- Ensure that the connector and cable are securely connected.

Storage

When storing this product, keep it in its original packing form.

- (1) Put the PC card in the storage bag.
- (2) Wrap it in the packing material, then put it in the box.
- (3) Store the package at room temperature at a place free from direct sunlight, moisture, shock, vibration, magnetism, and static electricity.

Disposal

When disposing of the product, follow the disposal procedures stipulated under the relevant laws and municipal ordinances.

2. Setup

This chapter explains how to set up the PC Card.

What is Setup?

Setup means a series of steps to take before the product can be used.

Different steps are required for software and hardware.

The setup procedure varies with the OS and software used.

Using the PC Card under Windows

Using the Driver Library API-PAC(W32)

This section describes the setup procedure to be performed before you can start developing application programs for the PC Card using the bundled CD-ROM “Driver Library API-PAC(W32)”.

Taking the following steps sets up the software and hardware. You can use the diagnosis program later to check whether the software and hardware function normally.

Step 1 Installing the Software

Step 2 Setting the Hardware

Step 3 Installing the Hardware

Step 4 Initializing the Software

Step 5 Checking Operations with the Diagnosis Program

If Setup fails to be performed normally, see the “Setup Troubleshooting” section at the end of this chapter.

Using the PC Card under Windows

Using Software Other than the Driver Library

API-PAC(W32)

For setting up software other than API-PAC(W32), refer to the user’s guide for that software. See also the following parts of this user’s guide as required.

This chapter Step 2 Setting the Hardware

This chapter Step 3 Installing the Hardware

Chapter 3 External Connection

Chapter 6 About Hardware

Using the PC Card under an OS Other than Windows

For using the PC Card under an OS other than Windows, see the following parts of this user's guide.

This chapter Step 2 Setting the Hardware

Chapter 3 External Connection

Chapter 6 About Hardware

Step 1 Installing the Software

This section describes how to install the Driver libraries.

Before installing the hardware on your PC, install the Driver libraries from the bundled API-PAC(W32) CD-ROM.

The following description assumes the operating system as Windows XP. Although some user interfaces are different depending on the OS used, the basic procedure is the same.

Starting the Install Program

- (1) Load the CD-ROM [API-PAC(W32)] on your PC.
- (2) The API-PAC(W32) Installer window appears automatically.
If the panel does not appear, run (CD-ROM drive letter):\AUTORUN.exe.
- (3) Click on the [Install the drivers] button.

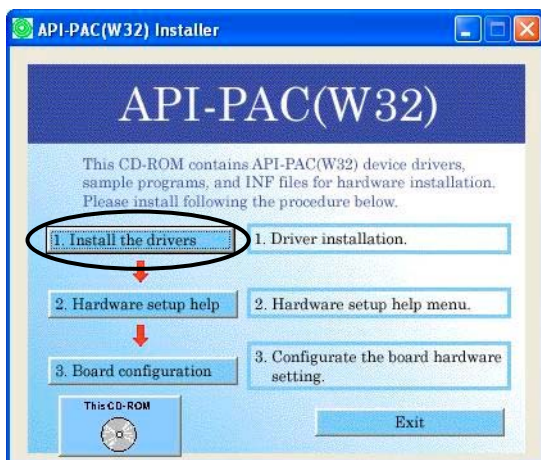

CAUTION

Before installing the software in Windows XP and 2000, log in as a user with administrator privileges.

Select the counter driver

- (1) The following dialog box appears to select “Driver Type” and “Install Type”.
- (2) Select “Counter API-CNT(98/PC)W95”.
- (3) Select “Driver, Help, etc..(Full Install)”.
- (4) Click on the [Install] button.

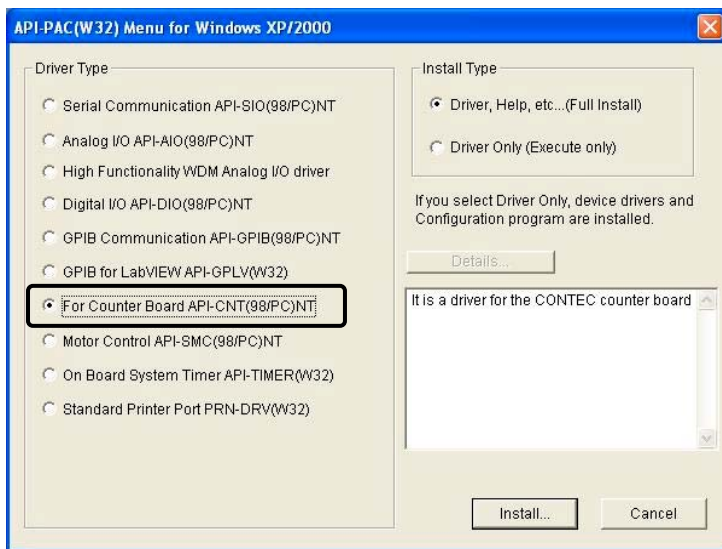

Executing the Installation

- (1) **Follow the on-screen instructions to proceed to install.**
- (2) When the required files have been copied, the “Perform a hardware setup now(API-TOOL Configuration)” and “Show readme file” check boxes are displayed.

When you are installing the software or hardware for the first time:

1) Uncheck “Perform a hardware setup now”.

2) Click on the [Finish] button.

Go to Step 2 to set and plug the hardware.

* When the hardware has already been installed:

Check “Perform a hardware setup now(API-TOOL Configuration)”, then go to Step 4 “Initializing the Software”.



You have now finished installing the software.

Step 2 Setting the Hardware

This section describes how to set the PC Card and plug it on your PC.

Connecting the connection cable to the PC Card

Connect the PC Card connector at one end of the connection optional cable [CNT-68M/50M or PCA68PS-**P] to the PC Card [CNT32-4MT(CB)]. Connect them together with the connector's flat side and PC Card's front surface face up as shown in Figure 2.1 below.

CAUTION

When connecting the connection cable with the PC Card, align their mating connectors and plug them straight into each other. Applying excessive force to the cable-side connector of the PC Card may break or make it loose.

Do not plug or unplug them with the PC powered.

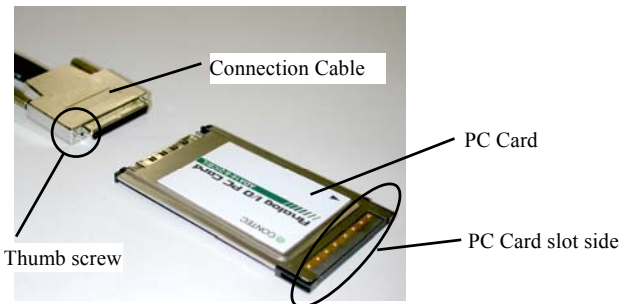

Figure 2.1. Connecting the connection cable to the PC Card

Plugging the PC Card

Make sure that the PC is off, then plug the PC Card into the PC Card slot in the PC.

Check the direction of the arrow mark ▼ on the PC Card and fit it well into the PC Card slot as shown in Figure 2.2.

Although the PC Card has an accidental insertion preventive groove, inserting the PC Card forcibly can break the slot and the Card. Note also that the PC Card slot on some PCs requires that the PC Card be inserted with the front side face down. Make sure before inserting the PC Card.

For notes on unplugging the PC Card, refer to the manual for your PC.

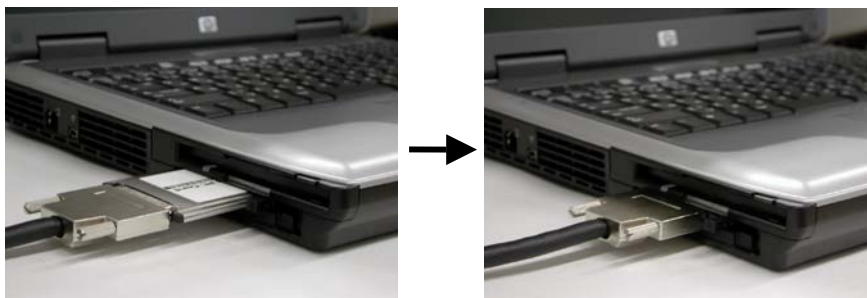

Figure 2.2. Plugging the PC Card



CAUTION

Take the following precautions not to break the PC Card or not to cause its connector to break or come loose.

- Do not insert the PC Card in reverse or by a procedure other than specified.
- Do not insert the PC Card while holding the connection cable or its connector.
- Do not move the PC with the connection cable connector plugged.
- Do not apply excessive force to the connector of the PC Card, for example, by forcing the connection cable connector off the PC Card.
- Do not place anything on the connection cable connector.

Notes on use of two or more PC Cards[CNT32-4MT(CB)]

If your PC has a stack of two TYPE II PC Card slots, two [CNT32-4MT(CB)] PC Cards cannot be used simultaneously in both slots. This is due to the shape of the cable connector.

The PC Card [CNT32-4MT(CB)] can be used along with another PC Card which does not use any external connector, such as a memory card.

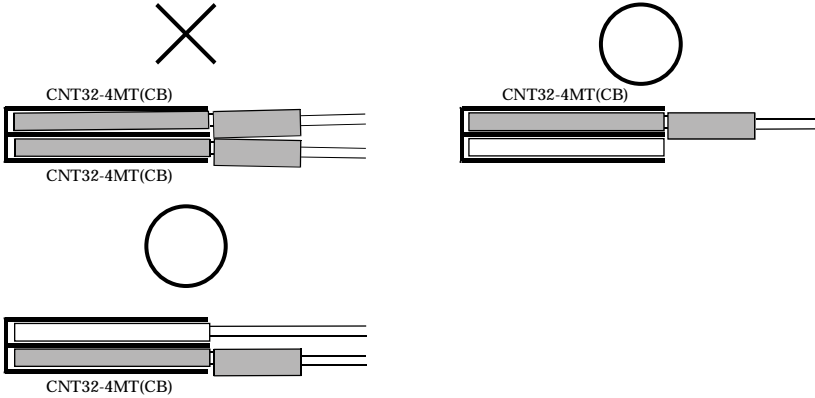

Figure 2.3. Notes on use of two or more PC Cards[CNT32-4MT(CB)]

CAUTION

The use of more than one PC Cards may be restricted depending on the number of PC Card slots, their locations, and/or on the specifications of the driver. For the driver specifications, refer to the help file for the driver.

Step 3 Installing the Hardware

For using an expansion board under Windows, you have to let the OS detect the I/O addresses and IRQ to be used by the PC Card. The process is referred to as installing the hardware.

In the case of using two or more PC Cards, make sure you install one by one with the Add New Hardware Wizard.

Turning on the PC

Turn on the power to your PC.



CAUTION

The PC Card cannot be properly installed unless the resources (I/O addresses and interrupt level) for the PC Card can be allocated. Before attempting to install the PC Card, first determine what PC resources are free to use.

Setting the Add New Hardware Wizard

- (1) The “Found New Hardware Wizard” will be started.
Select “Install from a list or specific location (Advanced)”, then click on the [Next] button.



- (2) Specify that folder on the CD-ROM which contains the setup information (INF) file to register the PC Card.



Source folder

The setup information (INF) file is contained in the following folder on the bundled CD-ROM.

- Windows XP, 2000 \INF\Win2000\Cnt\PCCard
- Windows Me, 98 \INF\Win95\Cnt\PCCard

Example of specifying the folder for use the CNT32-4MT(CB) under Windows XP

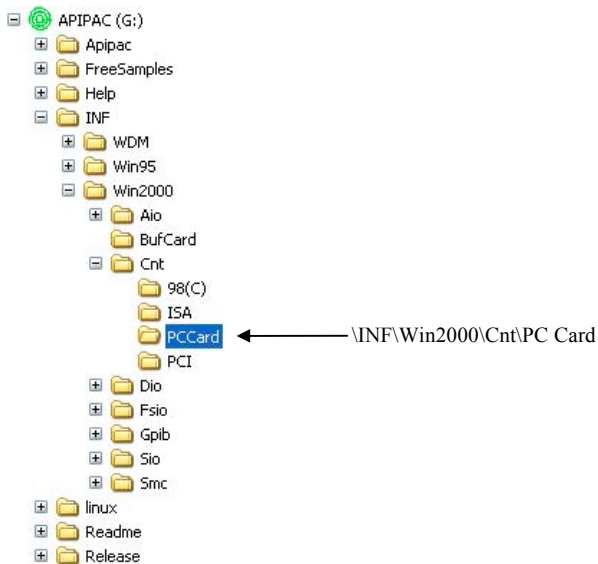

⚠ CAUTION

In Windows XP, the Hardware Wizard displays the following alert dialog box when you have located the INF file. This dialog box appears, only indicating that the relevant driver has not passed Windows Logo testing, and it can be ignored without developing any problem with the operation of the PC Card.

In this case, click on the [Continue Anyway] button.



You have now finished installing the hardware.

Step 4 Initializing the Software

The driver library requires the initial setting to recognize the execution environment. It is called the initialization of the driver library.

Invoking API-TOOL Configuration

- (1) Open the Start Menu, then select “Programs” – “CONTEC API-PAC(W32)” – “API-TOOL Configuration”.

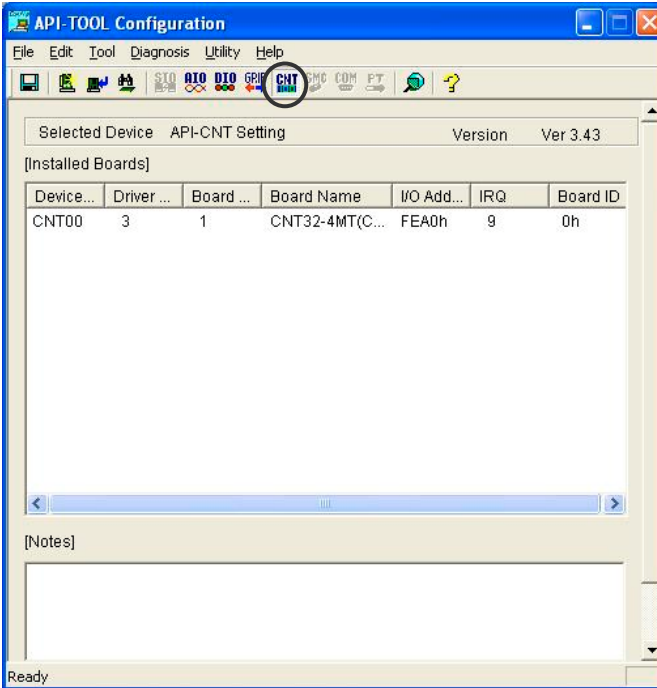

- (2) Click on the [CNT] icon.
API-TOOL Configuration detects PC Cards automatically.
The detected PC Cards are listed.

Updating the Settings

- (1) Select “Save setting to registry...” from the “File” menu.

You have now finished installing the initial setting of Software.

Step 5 Checking Operations with the Diagnosis Program

Use the diagnosis program to check that the PC Card and driver software work normally, thereby you can confirm that they have been set up correctly.

What is the Diagnosis Program?

The diagnosis program diagnoses the states of the PC Card and driver software.

The program has the following diagnosis methods for checking the PC Card as a single unit using its internal test pulses and the method for checking the PC Card actually connected to an external device.

- Checking the PC Card as a single unit (without external connection)
- Checking the PC Card as a single unit (with external connection)
- Checking the PC Card with an external device

To make sure that the hardware and software have been set up correctly, execute the program for “Checking the PC Card as a single unit (without external connection)”.

You can use the methods for “Checking the PC Card as a single unit (with external connection)” or “Checking the PC Card with an external device” to simply check the PC Card for wiring or for connection to an actually connected external device.

The program has the “diagnosis report” feature to report the driver settings, I/O status, interrupt status, and the presence or absence of the PC Card.

Check method 1: Checking the PC Card single-handedly (without external connection)

The diagnosis program checks whether the PC Card works normally as a single unit along with the driver using the on-board test pulse outputs. With the test pulse outputs set to internal, the PC Card can count pulse signals without external connection as if the PC Card were connected to an external device.

Set the PC Card to the factory defaults before using this method.

What is a test pulse output?

The PC Card has one test pulse output for phase-A and another for phase-B to check whether the counter inputs work normally. The output pulses are LVTTL level outputs fixed at 100 kHz.

The PC Card can also internally output test pulses to each counter channel without supplying them to the outside. In that case, the PC Card outputs two-phase pulses to all channels at the same time.

Check method 2: Checking the PC Card single-handedly (with external connection)

When the test pulse outputs are set to external outputs, the PC Card outputs LVTTTL level output pulses at 100 kHz from the output pins (TPOA and TPOB). Using the test pulse outputs for external connection, the diagnosis program can check whether the input circuit of the PC Card normally works as a single unit along with the driver. Using the test pulse outputs allows the PC Card to count pulse signals as if it were actually connected to an external device. See the following section for the connection.

If the PC Card fails to perform counting normally by check method 2, its input circuit may be defective.

Test pulse output circuit and its sample connection (TPOA and TPOB)

CNT32-4MT(CB) has one test pulse output for phase-A and another for phase-B for self-diagnosis purposes. The output pulses are LVTTTL level output at fixed 100 kHz.

To check the PC Card in single-phase input mode, connect either the phase-A or phase-B test pulse output only. The PC Card performs up-counting (incremental counting) or down-counting (decremental counting) with only the phase-A or phase-B test pulse output connected, respectively.

Connect the pull up pin to the 3.3V output pin.

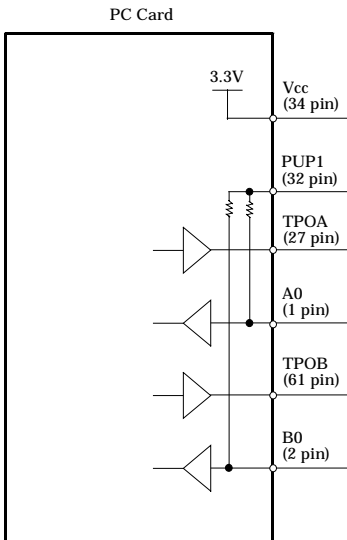

Pin numbers in the diagram shows those of connector on the PC Card.

Figure 2.4. Sample connection to counter input circuit (ch0)

Check method 3: Checking the PC Card using an external device

The diagnosis program tests the PC Card actually connected to an external device to check whether count values are displayed correctly and whether signals are successfully turned on/off. See the following section about how they are connected.

If the PC Card fails to perform counting normally by check method 3, the PC Card may be connected incorrectly or the connected device may not be compliant with the specifications.

Connection diagram

Use the following connection to connect to CH0 via PCA68PS-**P cable and a rotary encoder with a TTL level output/open-collector output. For connection to another channel and for the details on signal position, see Chapter 3 "External Connection".

< Sample connection to rotary encoder (channel 0) >

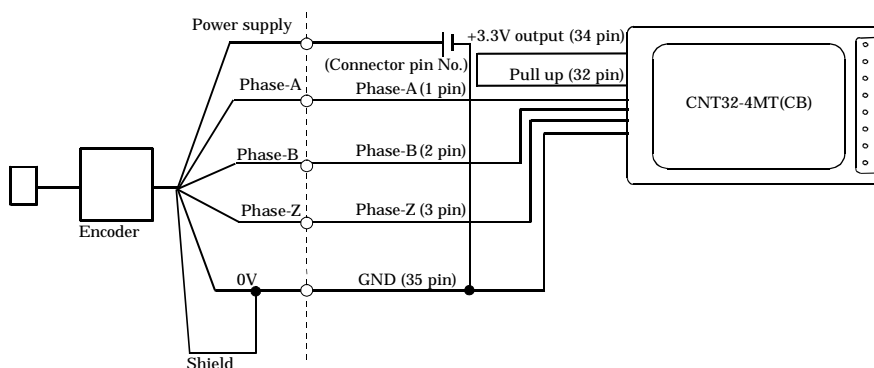

Pin numbers in the diagram shows those of connector on the PC Card.

Figure 2.5. Connection diagram

Using the Diagnosis Program

Starting the Diagnosis Program

Select the PC Card in the API-TOOL Configuration windows, then run the Diagnosis Program. Please operate in accordance with the instruction of following screen.

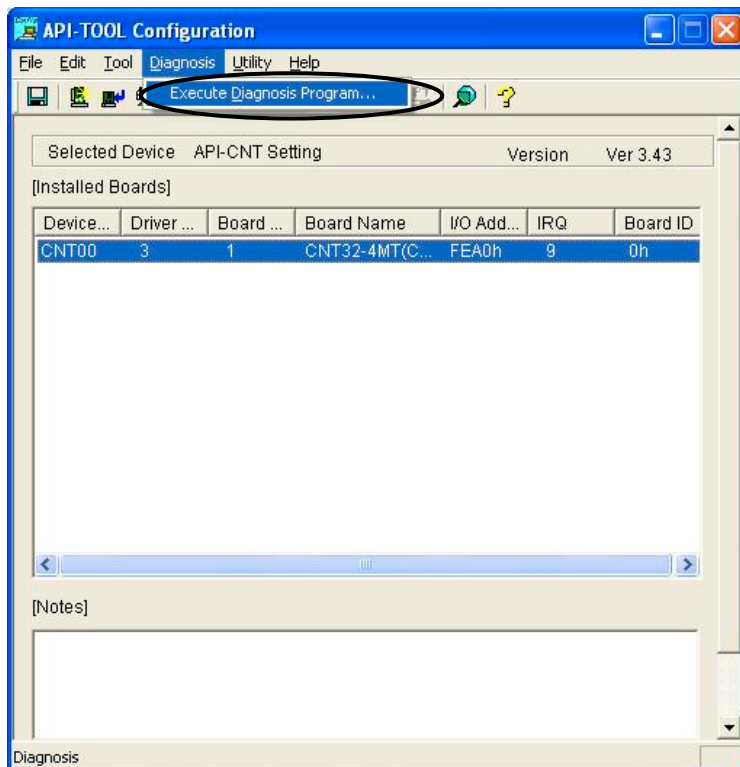

Setting counter operation conditions

- (1) Change counter mode settings. Click on [Counter Mode...].

The Counter Mode setting dialog box appears.

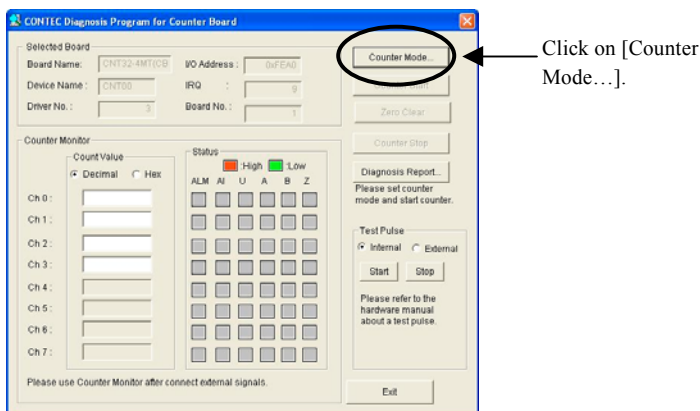

- (2) Set the counter mode for channel 0. Leave the other settings at factory defaults. Click on [Use Same Mode]

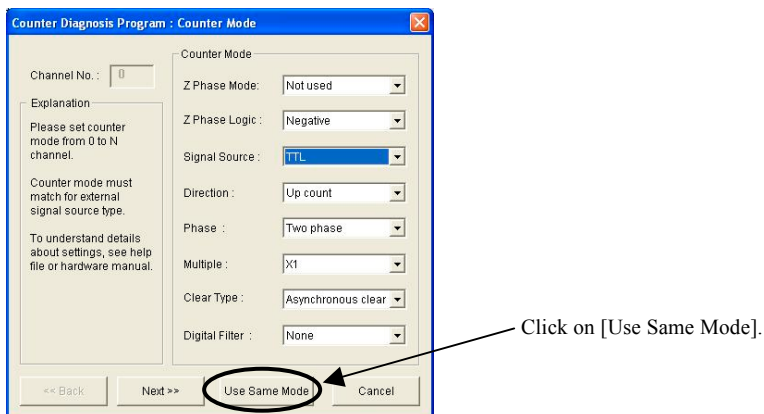

(3) Click on [End].

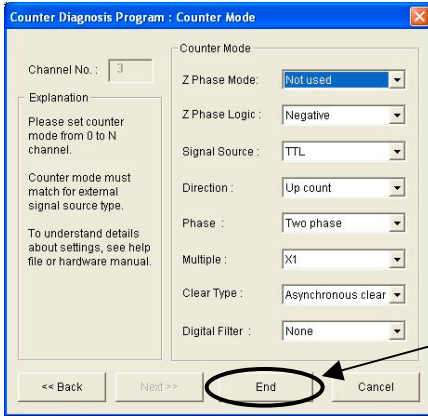

Click on [End].

Checking counter operations

The following commands can be used to check the basic operations of the counter.

- [Counter Start] : Starts the counter.
 [Zero Clear] : Clears the counter to zero.
 [Counter Stop] : Stops the counter.

- (1) Click on [Counter Start].

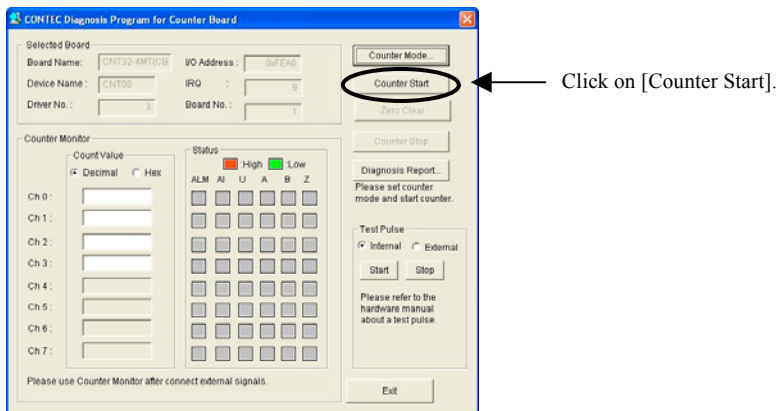

- (2) The counter value of each channel is displayed along with its status (ALM, AI, U, A, B, Z).

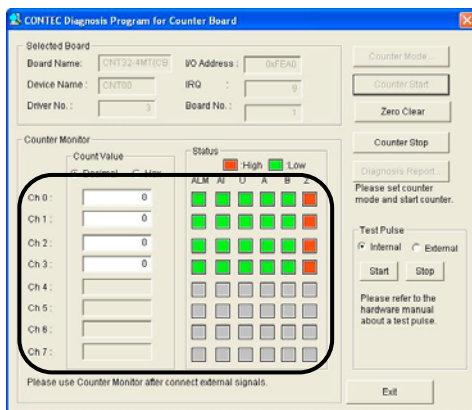

- (3) Clicking on [Start] with “Test Pulse” set to “Internal” outputs two-phase line receiver signals to all channels, allowing you to check their count value and status.

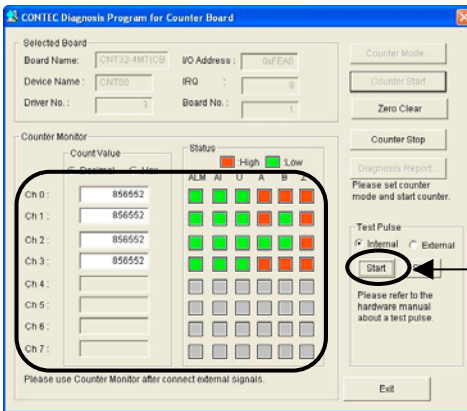

Click on [Start].

Diagnosis Report

- (1) Clicking on [Diagnosis Report...] displays detailed data such as PC Card and channel settings and the diagnosis results as saved in text format.

The saved results are displayed as a text file (CntRep.txt) in the install folder (Program Files\CONTEC\API-PAC(W32)).

The diagnosis program performed includes "PC Card presence/absence check", "interrupt test", "driver file test", "PC Card setting test".

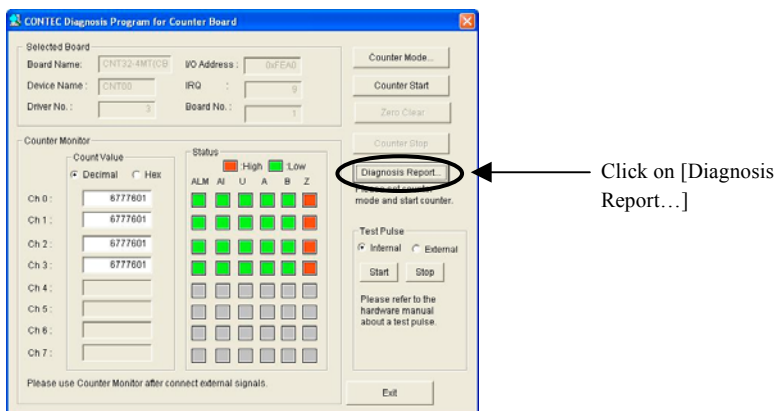

- (2) A diagnosis report is displayed as shown below.

```

CNTREP.TXT - Notepad
File Edit Format View Help
CONTEC Counter Diagnosis Report.
Diagnosis Program : Ver1.20
Date : 2004/12/06 14:01:13

OS :Microsoft windows XP 5.1.0 Service Pack 1
-----
1. Files
  Driver files:Files are installed.
  Configuration files:Files are installed.
2. Configuration settings
-----
Device Name :CNT00
Driver No :3
Group No :0
Board No :1
Board Name :CNT32-4MT(CB)
I/O address :FEA0h
IRQ :9
Board ID :0

Details : Counter Mode :
-----
Channel : 0
  ZMODE = Not used
  ZLOGIC = Negative
  SIGTYPE = TTL
  DIR = Up count
  PHASE = Two phase
  MUL = x1
  CLRAR = Asynchronous clear
  FILTER = None
-----
Channel : 1
  
```

Setup Troubleshooting

Symptoms and Actions

No count value can be read.

The counter mode setting may be inappropriate.

The PC Card won't work successfully unless the counter mode is set according to the input signal format. Refer to the function description in API-CNT HELP or the user's guide for the PC Card to configure the appropriate counter mode.

The PC Card works with the Diagnosis Program but not with an application.

The Diagnosis Program is coded with API-TOOL functions. As long as the PC Card operates with the Diagnosis Program, it is to operate with other applications as well. In such cases, review your program while paying attention to the following points:

- Check the arguments to functions and their return values.
- Check whether the counter mode is appropriate for the incoming signal format.

The OS won't normally get started or detect the PC Card. [Windows XP, 2000]

Turn off the power to your PC, then unplug the PC Card. Restart the OS and delete the PC Card settings of API-TOOL Configuration. Turn off the PC again, plug the PC Card, and restart the OS. Let the OS detect the PC Card and use API-TOOL Configuration to register PC Card settings.

If your problem cannot be resolved

Contact your retailer.

3. External Connection

This chapter describes the interface connectors on the PC Card and the external I/O circuits. Check the information available here when connecting an external device.

Using the On-PC Card Connectors

Connecting a PC Card to a Connector

Use the optional connection cable (CNT-68M/50M or PCA68PS-**P, PCB68PS-**P) to connect the PC Card to an external device. Use the cable together with a terminal block for the wiring between the PC Card and external device.

< CNT-68M/50M >

- Cable
- 68-conductor shielded cable
- Cable length : 500mm
- Conductor size : AWG#30

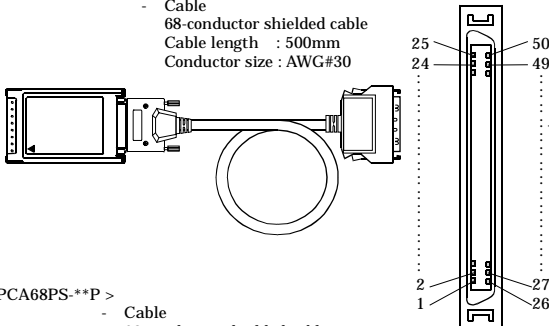

- Connector used
50 pin mini ribbon connector
10250-52AJL [3M] or equivalent to it

< PCA68PS-**P >

- Cable
- 68-conductor shielded cable
- Cable length : PCA68PS-0.5 500mm
- PCA68PS-1.5 1500mm
- Conductor size : AWG#30

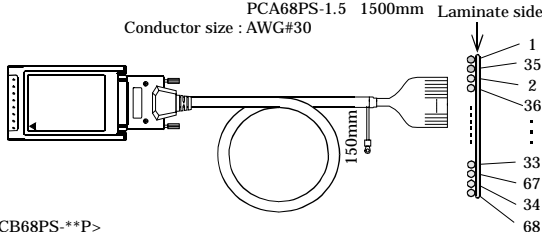

<PCB68PS-**P>

- Cable
- 68conductor Shield cable
- Cable length : PCB68PS-0.5P 500mm
- PCB68PS-1.5P 1500mm
- Conductor size : AWG#30

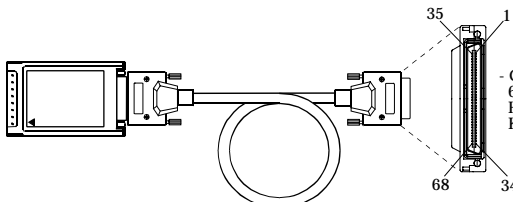

- Connector used
68-pin 0.8mm-pitch connector
HDRA-E68M41[HONDA TSUSHIN
KOGYO CO., LTD.] or equivalent

Figure 3.1. Interface connector and used connector

Connector Pin Assignment

CNT32-4MT(CB) Interface Connector Pin Assignment

CH0 phase-A input	A0	1	35	- GND	Ground
CH0 Phase-B input	B0	2	36	- GND	Ground
CH0 Phase-Z input	Z0	3	37	- GND	Ground
CH0 control input *1	D0	4	38	- GND	Ground
Unconnection	N.C.	5	39	- N.C.	Unconnection
CH1 Phase-A input	A1	6	40	- GND	Ground
CH1 Phase-B input	B1	7	41	- GND	Ground
CH1 Phase-Z input	Z1	8	42	- GND	Ground
CH1 control input *1	D1	9	43	- GND	Ground
Unconnection	N.C.	10	44	- N.C.	Unconnection
CH2 Phase-A input	A2	11	45	- GND	Ground
CH2 Phase-B input	B2	12	46	- GND	Ground
CH2 Phase-Z input	Z2	13	47	- GND	Ground
CH2 control input *1	D2	14	48	- GND	Ground
Unconnection	N.C.	15	49	- N.C.	Unconnection
CH3 Phase-A input	A3	16	50	- GND	Ground
CH3 Phase-B input	B3	17	51	- GND	Ground
CH3 Phase-Z input	Z3	18	52	- GND	Ground
CH3 control input *1	D3	19	53	- GND	Ground
Unconnection	N.C.	20	54	- N.C.	Unconnection
Sampling clock input	CLKIN	21	55	- GND	Ground
Sampling stop input	STOPIN	22	56	- STARTIN	Sampling start input
Unconnection	N.C.	23	57	- N.C.	Unconnection
Sampling clock output	CLKOUT	24	58	- GND	Ground
Sampling stop output	STOPOUT	25	59	- STARTOUT	Sampling start output
Unconnection	N.C.	26	60	- N.C.	Unconnection
Test pulse Phase-A output	TPOA	27	61	- TPOB	Test pulse Phase-B output
Unconnection	N.C.	28	62	- N.C.	Unconnection
CH0 control output *2	DO0	29	63	- DO1	CH1 control output *2
CH2 control output *2	DO2	30	64	- DO3	CH3 control output *2
Unconnection	N.C.	31	65	- N.C.	Unconnection
Counter input signal pull up	PUP1	32	66	- PUP2	Control input signal pull up
Unconnection	N.C.	33	67	- N.C.	Unconnection
+3.3V output *3	Vcc	34	68	- Vcc	+3.3V output *3

*1 The control input can serve as the general-input, counter start/stop, preset, and zero-clear.

*2 The control output can serve as the general-output, count match, abnormal input error and digital filter error.

*3 Supply-capable current is 500mA (Max.).

Figure 3.2. Pin Assignment of an interface connector(CN1)(PC Card side)

CNT-68M/50M Pin Assignment

+3.3V Output *3	N.C.	25	50	- Vcc	+3.3V Output *3
Counter Input signal pull-up	AGND	24	49	- PUP2	Counter Input signal pull-up
CH2 control output *2	N.C.	23	48	- DO3	CH3 control output *2
CH0 control output *2	AGND	22	47	- DO1	CH1 control output *2
Test pulse Phase-A output	AI 04	21	46	- TPOB	Test pulse Phase-B output
Sampling Stop Output	N.C.	20	45	- STARTOUT	Sampling Start Output
Sampling Clock Output	AI 05	19	44	- GND	Ground
Sampling Stop Input	N.C.	18	43	- STARTIN	Sampling Start Input
Sampling Clock Input	AGND	17	42	- GND	Ground
CH3 Control Input *1	AGND	16	41	- GND	Ground
CH3 Phase-Z input	AI 06	15	40	- GND	Ground
CH3 Phase-B input	N.C.	14	39	- GND	Ground
CH3 Phase-A input	AI 07	13	38	- GND	Ground
CH2 Control Input *1	N.C.	12	37	- GND	Ground
CH2 Phase-Z input	AO START	11	36	- GND	Ground
CH2 Phase-B input	AO STOP	10	35	- GND	Ground
CH2 Phase-A input	AO EXCLK	9	34	- GND	Ground
CH1 Control Input *1	DGND	8	33	- GND	Ground
CH1 Phase-Z input	DO 00	7	32	- GND	Ground
CH1 Phase-B input	DO 01	6	31	- GND	Ground
CH1 Phase-A input	DO 02	5	30	- GND	Ground
CH0 Control Input *1	DO 03	4	29	- GND	Ground
CH0 Phase-Z input	DGND	3	28	- GND	Ground
CH0 Phase-B input	CNT UPCLK	2	27	- GND	Ground
CH0 Phase-A input	Reserved	1	26	- GND	Ground

*1 The control input can serve as the general-input, counter start/stop, preset, and zero-clear.

*2 The control output can serve as the general-output, count match, abnormal input error and digital filter error.

*3 Supply-capable current is 500mA (Max.).

Figure 3.3. Pin Assignment of CNT-68M/50M

How to Connect the Counter Input Signal

You can connect to a rotary encoder or linear scale with a TTL level output circuit, or to an open-collector output circuit. The signal must be an LVTTTL level input and can be up to 10MHz.

As pull-up resistors are provided on the PC Card, connect the pull-up voltage (3.3V to 5.5V max.) to the pull-up pins if connecting to an open collector output circuit/TTL level output circuit. (If using 3.3V, connect to the VCC pin on the PC Card.) Not connecting the pull-up voltage may affect the counter input channel left unconnected.

For a two-phase input, connect both phase A and phase B. For a single phase input, connect to either phase A or phase B. If not using the Z phase, this does not need to be connected.

Remarks

The pull-up pins are PUP1 (pin 32 *1) for the counter input signal and PUP2 (pin 66 *1) for the control input signal.

PUP1 (pin 32): Pull-up for A, B, and Z phase input signal
(A0, B0, Z0, A1, B1, Z1, A2, B2, Z2, A3, B3, Z3).

PUP2 (pin 66): Pull-up for the control input signals and for the sampling input signals
(DI0, DI1, DI2, DI3, CLKIN, STARTIN, STOPIN).

*1: Connector pin number on the PC Card.

Example Connection for Counter Input Circuit

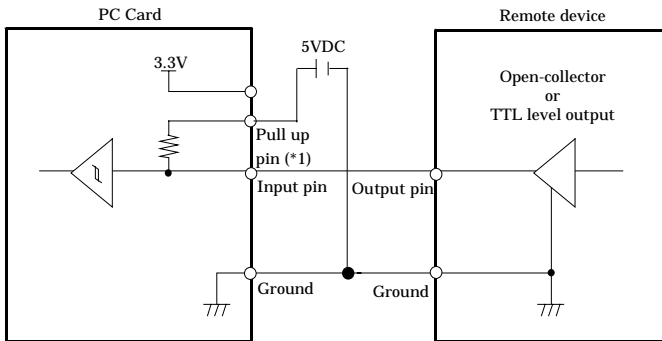

*1: The pull-up pins are PUP1 for the counter input signal and PUP2 for the control input signal.

Figure 3.4. Connection pulled up with external 5-V power (Counter Input)

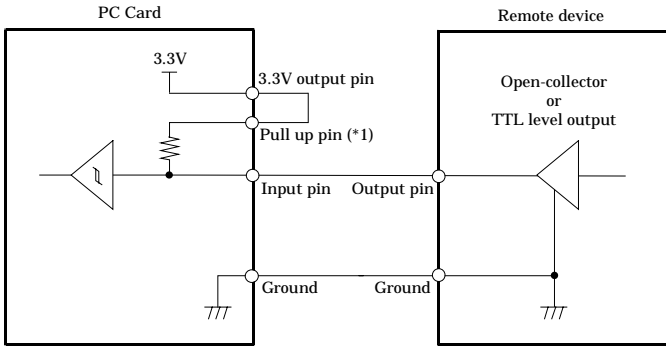

*1: The pull-up pins are PUP1 for the counter input signal and PUP2 for the control input signal.

Figure 3.5. Connection pulled up with internal 3.3-V output power (Counter Input)

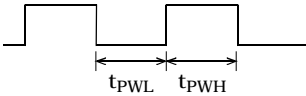

t_{PWH} : High-level count input pulse width 50nsec (Min.)

t_{PWL} : Low-level count input pulse width 50nsec (Min.)

Figure 3.6. Input signal



CAUTION

- The connection cable length should be within 1.5 m.
- To prevent noise from causing a malfunction, arrange the connection cable as away from any other signal conductor or noise source as possible.

Example Connection with a Rotary Encoder

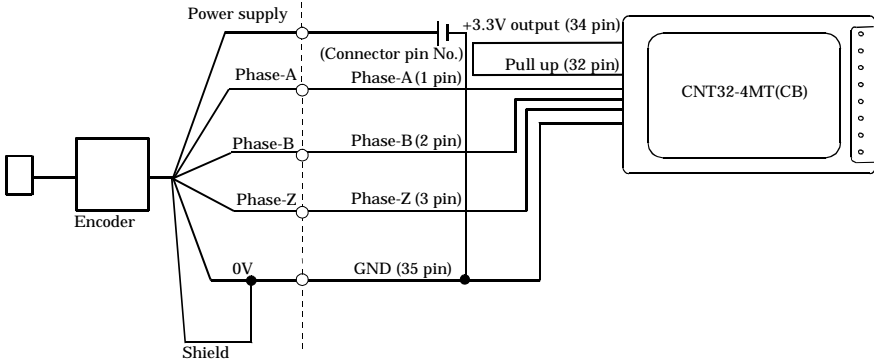

Pin numbers in the diagram shows those of connector on the PC Card.

Figure 3.7. Sample connection to rotary encoder (Channel 0)

Example Connection with a Linear Scale

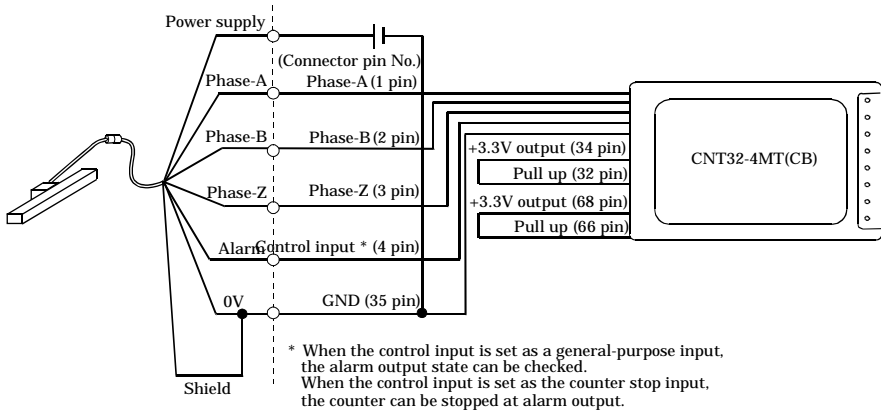

Pin numbers in the diagram shows those of connector on the PC Card.

Figure 3.8. Example Connection with a Linear Scale (channel 0)

Connecting the control signal input/output

Connection of a control input

The control input signals consist of one pin per channel that can be selected as the channel's counter start/stop or preset, and one pin per PC Card that can be used as the start, stop, and clock for sampling. The signals are LVTTTL-level inputs.

As pull-up resistors (10K Ω) are provided on the PC Card, connect the pull-up voltage (3.0V to 5.5V max.) to the pull-up pins if connecting to an open collector output circuit/TTL level output circuit. (If using 3.3V, connect to the VCC pin on the PC Card.) Not connecting the pull-up voltage may affect the control input pin left unconnected.

Remarks

The pull-up pins are PUP1 (pin 32 *1) for the counter input signal and PUP2 (pin 66 *1) for the control input signal.

PUP1 (pin 32): Pull-up for A, B, and Z phase input signal

(A0, B0, Z0, A1, B1, Z1, A2, B2, Z2, A3, B3, Z3).

PUP2 (pin 66): Pull-up for the control input signals and for the sampling input signals (DI0, DI1, DI2, DI3, CLKIN, STARTIN, STOPIN).

*1: Connector pin number on the PC Card.

Control input circuit and its sample connection

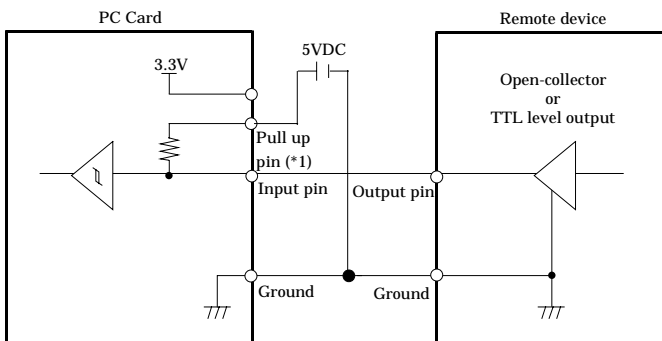

*1: The pull-up pins are PUP1 for the counter input signal and PUP2 for the control input signal.

Figure 3.9. Connection pulled up with external 5-V power
(Control input DI0, DI1, DI2, DI3, CLKIN, STARTIN, STOPIN)

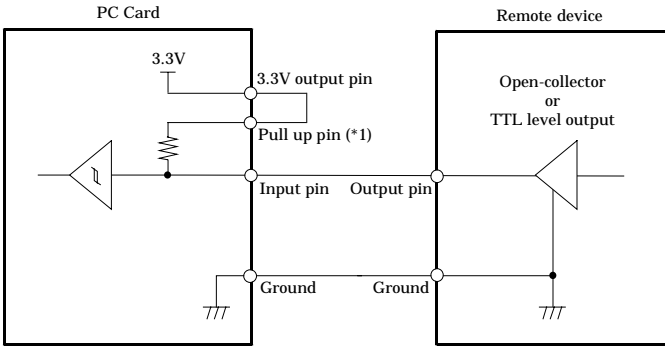

*1: The pull-up pins are PUP1 for the counter input signal and PUP2 for the control input signal.

**Figure 3.10. Connection pulled up with internal 3.3-V output power
(Control input DI0, DI1, DI2, DI3, CLKIN, STARTIN, STOPIN)**

⚠ CAUTION

- The connection cable length should be within 1.5 m.
 - To prevent noise from causing a malfunction, arrange the connection cable as away from any other signal conductor or noise source as possible.
-

External sampling clock signal (EXTCLK)

Pin used to input the external pacer clock. The maximum frequency is 10MHz.

If the external clock input is selected as the sampling clock, sampling occurs on the falling edge of the signal.

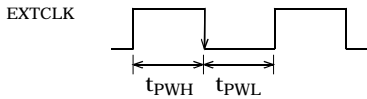

t_{PWH} : High-level clock pulse width 50nsec (Min.)

t_{PWL} : Low-level clock pulse width 50nsec (Min.)

Figure 3.11. External sampling clock signal

Other control input signals (DI0 to DI3, EXTSTART, EXTSTOP)

These signals are TTL level compatible and the trigger edge is software-programmable at either the rising or falling edge. High- and low-level hold times of at least 50 nsec are required to detect an edge of the signal.

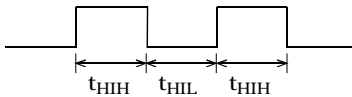

t_{H1H} : High-level hold time 50nsec (Min.)

t_{H1L} : Low-level hold time 50nsec (Min.)

Figure 3.12. Control input signals

Connection of a control output

This outputs a general-purpose output signal (level output) or a one-shot pulse output to indicate a hardware event such as a count match. The signal is an LVTTTL level output and can be set to positive or negative logic by software.

Control output circuit and its sample connection

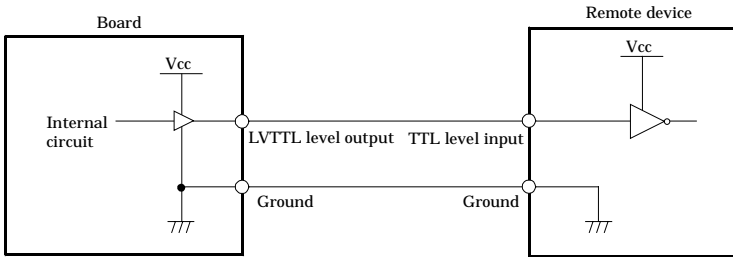

Figure 3.13. Sample connection to control output circuit (DO0 to DO3, CLKOUT, STARTOUT, STOPOUT)

4. Functions

This chapter describes the functions of the CNT32-4MT(CB).

Types and Operations of Pulse Signals

Types of pulse signals

The following types of pulse signals (operation modes) can be set.

- 2-phase Input, Synchronous Clear, Multiply by 1
- 2-phase Input, Synchronous Clear, Multiply by 2
- 2-phase Input, Synchronous Clear, Multiply by 4
- 2-phase Input, Asynchronous Clear, Multiply by 1
- 2-phase Input, Asynchronous Clear, Multiply by 2
- 2-phase Input, Asynchronous Clear, Multiply by 4
- Single-phase Input, Asynchronous Clear, Multiply by 1
- Single-phase Input, Asynchronous Clear, Multiply by 2
- Single-phase Input with Gate Control Attached, Asynchronous Clear, Multiply by 1
- Single-phase Input with Gate Control Attached, Asynchronous Clear, Multiply by 2

2-phase Input

A two-phase pulse input consists of two pulse inputs phase A (advanced signal) and phase B (delayed signal) with a phase difference of 90°C.

If the Z phase (reference position signal) is used, the two-phase pulse input can clear the count value to zero.

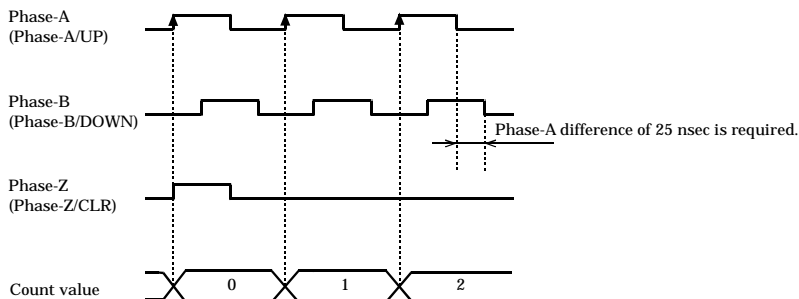

- * Count operation for incremental counting in the CW direction. When decremental counting in the CW direction is set, the PC Card performs decremental counting at the rising edge of the phase-A signal.
- * The minimum phase difference between phases-A and B is 25 nsec. Counting is not performed normally if the phase difference is less than 25 nsec.

Figure 4.1. Example counting during 2-phase input

Single-phase Input

For a single-phase input, the count increments when an UP pulse is input and decremented when a DOWN pulse is input. The count remains unchanged if UP and DOWN pulses are input simultaneously.

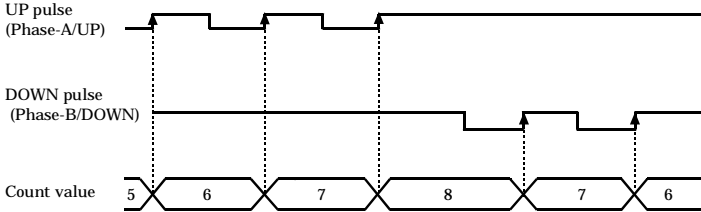

* Count operation for incremental counting in the CW direction. When decremental counting in the CW direction is set, the PC Card performs decremental counting at the rising edges of positive pulse and incremental counting at the rising edges of negative pulses.

Figure 4.2. Example counting during single-phase input

Single-phase Input with Gate Control Attached

The counter can be started and stopped using a gate control signal input along with the single-phase pulse stream.

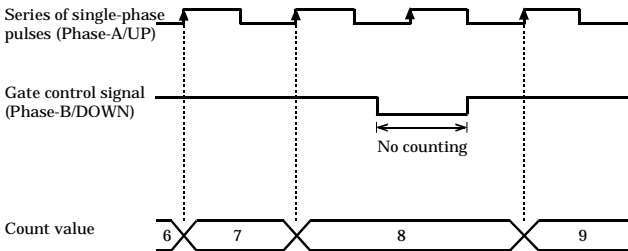

* Count operation for incremental counting in the CW direction. When decremental counting in the CW direction is set, the PC Card performs decremental counting at the rising edges of the single-phase pulse train (phase-A/UP) while the gate control signal (phase-B/DOWN) goes high and stops counting while the gate control signal goes low.

Figure 4.3. Example counting during single-phase input with gate control attached

Multiplication of Count Input

Setting the count input multiplication setting to two or four times enables you to fine-tune controlling.

During 2-phase input

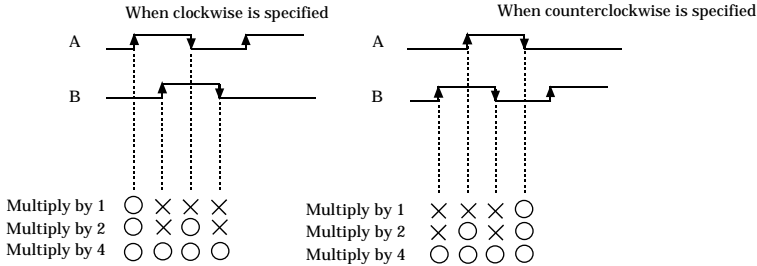

Single-phase input

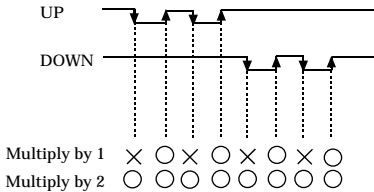

Single-phase input with gate control attached

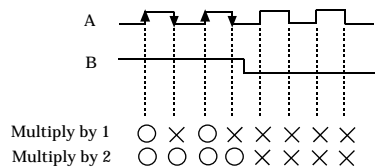
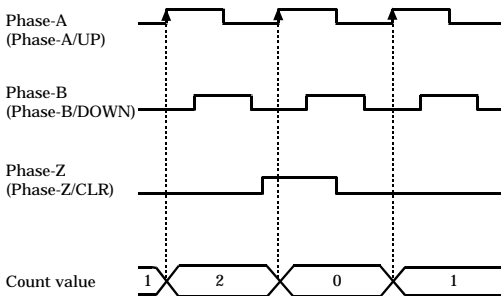

Figure 4.4. Example counting when count input multiplication is set

Synchronous Clear

When incremental counting in the CW (clockwise) direction is set with phase-Z positive logic, the PC Card clears the counter at the rising edge of the phase-A signal while the phase-Z input goes high and starts counting at the rising edge of the phase-A signal after the phase-Z input goes low.



* When decremental counting in the CW direction is set, the PC Card performs decremental counting at the rising edge of the phase-A signal while the phase-B input remains low.

Figure 4.5. Example counting during synchronous clear

Asynchronous Clear

When incremental counting in the CW (clockwise) direction is set with phase-Z positive logic, the PC Card clears the counter when the phase-Z input goes high while phases A and B are in the input state. The PC Card starts counting at the rising edge of the phase-A signal while phase-Z in the input state.

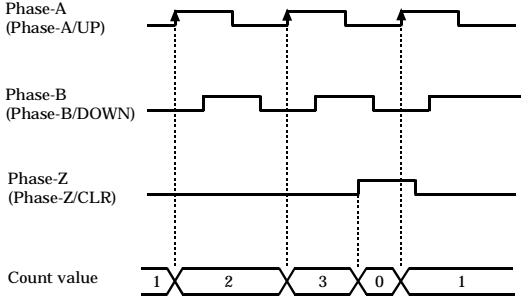

* When incremental counting in the CW direction is set with phase-Z positive logic, the PC Card performs decremental counting at the rising edge of the phase-A signal while the phase-B input remains low. When phase-Z negative logic is used, the signal is enabled while the phase-Z input remains low.

Figure 4.6. Example counting during asynchronous clear

Phase-Z/CLR Input

Phase-Z is the signal to clear the counter to zero. The number of phase-Z inputs can be specified by software.

Disable phase-Z input

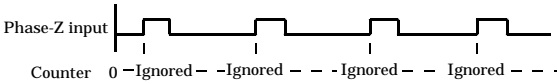

Enable the next phase-Z input only once

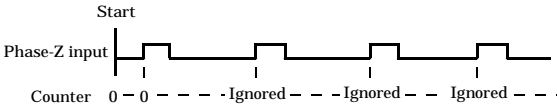

Enable every phase-Z input

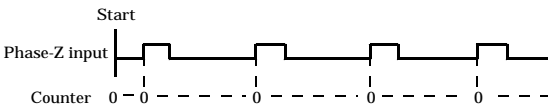

Figure 4.7. Phase-Z enable frequency(Positive logic)

⚠ CAUTION

- The initial setting is “only the next phase-Z input is enabled once”.
- Phase-Z (negative logic) is enabled while the phase-Z input goes low.
- When the phase-Z/CLR input is not used, be sure to disable the phase-Z input.

Control of a counter

Counter start/Counter stop

The counters on the PC Card can be started and stopped individually for each channel or globally for all channels. The table below lists the counter start and stop triggers. Which triggers to use can be selected by software.

Table 4.1. Counter operation

Item	Factor	Description	Note
Counter start trigger	Software command (for all/each of channels)	Possible to start the counter for all or each of the channels.	
	Rise of control input signal	The counter is started at a level change (low-to-high transition).	Available only when the control input signal has been selected for counter start/stop.
	Fall of control input signal	The counter is started at a level change (high-to-low transition).	Available only when the control input signal has been selected for counter start/stop.
	Sampling start	Sampling start = counter start	
Counter stop trigger	Software command (for all/each of channels)	Possible to stop the counter for all or each of the channels.	
	Rise of control input signal	The counter is ended at a level change (low-to-high transition).	Available only when the control input signal has been selected for counter start/stop.
	Fall of control input signal	The counter is ended at a level change (high-to-low transition).	Available only when the control input signal has been selected for counter start/stop.
	Sampling stop	Sampling stop = counter stop	0

Software

The counter is started or stopped by software either for each channel or for all channels.

Rise/fall of an external input signal

The counter is started or stopped by an external input signal supplied through the control input pin.

The rising or falling edge of the signal can be selected for starting or stopping the counter. If the “low-to-high” transition is set for both starting and stopping the counter, the counter is started or stopped if it is inactive or active, respectively, when the level changes from low to high.

* When the control input pin is used for the counter start/stop signal, it cannot be used for the preset, zero-clear, or general-purpose input.

Sampling start/stop

When the counter start trigger is used for starting sampling, the PC Card starts counting and sampling synchronously. When the counter stop trigger is used for stopping sampling, the PC Card stops counting and sampling synchronously in the same way.

Preset

Presetting means setting the counter to an arbitrary value.

The value in the preset register is loaded into the counter. Preset methods are listed in the table below, which are software-selectable.

Table 4.2. Preset

Item	Factor	Description	Note
Preset method	Software command	Possible to preset for all channels	Always available
	Control input signal (rise)	Control input level change (Low to High)	Available only when the control input signal has been selected for presetting.
	Control input signal (fall)	Control input level change (High to Low)	Available only when the control input signal has been selected for presetting.
	Count match(Register0)	Count value = Comparison register 0	
	Count match(Register1)	Count value = Comparison register 1	

Software

The counter is presetting by software either for each channel or for all channels.

Rise/fall of an external input signal

The counter is presetting by an external input signal supplied through the control input pin. The control input pin is used for preset signal input. The rising or falling edge of the signal can be selected.

- * When the control input pin is used for presetting, it cannot be used for the counter start/stop, zero-clear, or general-purpose input.

Count match

The counter is preset when the count value matches the value in comparison register 0 or 1.

Zero-clear

The counter is cleared to zero. Zero-clear methods are listed in the table below. The zero-clear method is software-selectable.

Table 4.3. Zero-clear

Item	Factor	Description	Note
Zero-clear method	Software command	Possible to preset for all channels	Always available
	Phase-Z input	Phase-Z input level change	Always available
	Control input signal (rise)	Level change	Available only when the control input signal has been selected for Zero-clearing.
	Control input signal (fall)	Level change	Available only when the control input signal has been selected for Zero-clearing.
	Count match(Register0)	Count value = Comparison register 0	
	Count match(Register1)	Count value = Comparison register 1	

Software

The counter is zero-cleared by software either for each channel or for all channels.

Phase-Z Input

The counter is zero-cleared by the external phase-Z input signal. Software is used to select positive or negative logic and to enable or disable zero-clearing.

Rise/fall of an external input signal

The counter is zero-cleared by an external input signal supplied through the control input pin. The control input pin is used for preset signal input. The rising or falling edge of the signal can be selected.

* When the control input pin is used for zero-clearing, it cannot be used for the counter start/stop, preset, or general-purpose input.

Count match

The counter is zero-cleared when the count value matches the value in comparison register 0 or 1.

Register

The PC Card has a preset register and comparison registers.

Preset Register

The preset register is a 32-bit register to load the value in the preset register to the counter when presetting occurs.

Comparison register 0, Comparison register 1

These are 32-bit registers. A variety of events can occur when the counter value matches the value in comparison register 0 or 1.

Obtaining the count value

Obtaining the count value

There are two modes for obtaining the count value. One is the counter mode to directly read the count value without using bus mastering and the other is the sampling mode to sample the count value periodically using bus mastering.

This PC Card is capable of bus mastering, enabling periodical sampling of the count value using the internal or external clock signal.

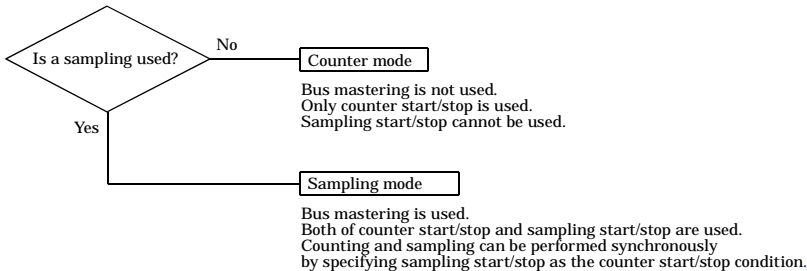

Figure 4.8. Counter mode and sampling mode

Counter mode

In the counter mode, the PC Card starts the counter after setting counter operation conditions and performs counter operations such as reading the count value and status.

In addition, this mode allows the PC Card to preset, zero-clear, start/stop the counter at the rising or falling edge of the control input signal. A one-shot pulse can be output to the control input signal at an occurrence of a count match or error.

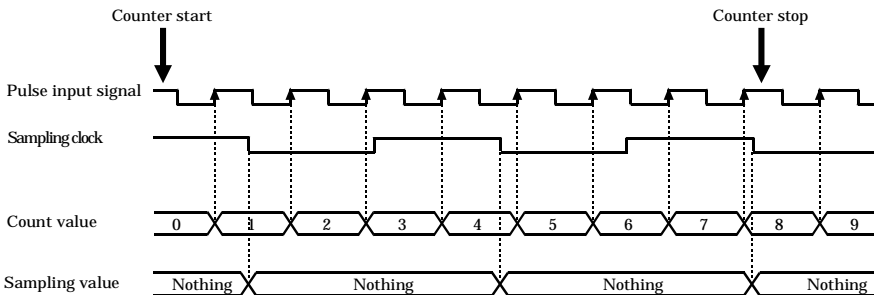

Figure 4.9. Timing chart (Counter mode)

Sampling mode

In the sampling mode, the PC Card samples the count value periodically to load it into memory on the PC according to the specified internal or external clock. The area of memory to store sampling data is a maximum of 64 MB (16777216 data items), which is restricted depending on the OS used. In particular, Windows XP, 2000 allows less memory to be allocated relative to the total amount of physical memory. For use under such an OS, therefore, the area of memory that can be allocated should be checked with a sample program.

For the sampling mode, sampling operation conditions must be set as well as counter operation conditions. For details about sampling, see “Sampling function” described later in this chapter. The counter start can be synchronized with the sampling start.

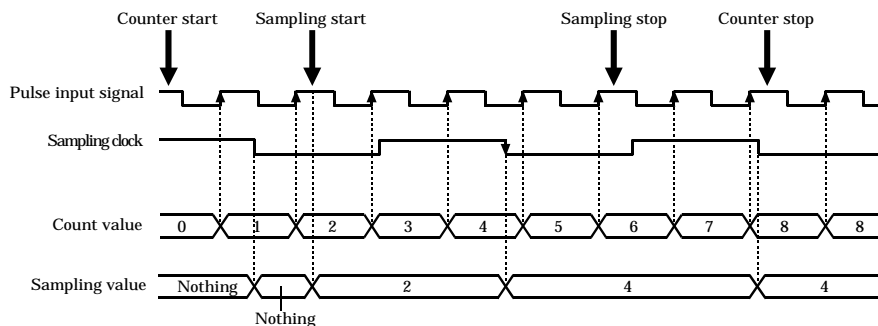

Figure 4.10. Timing chart (Counter-asynchronous sampling mode)

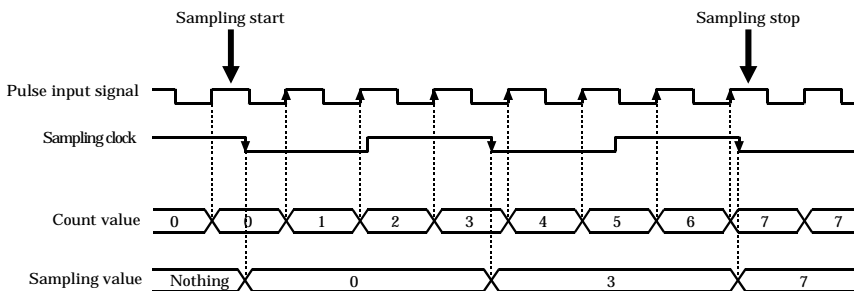
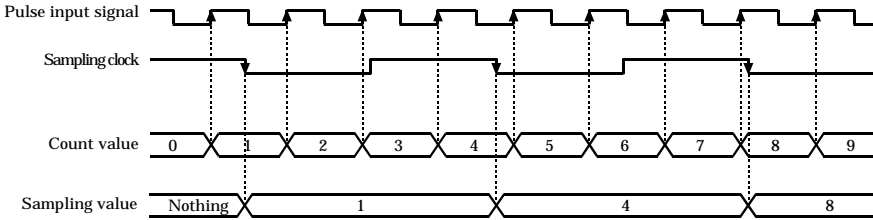

Figure 4.11. Timing chart (Counter-synchronous sampling mode)

Totalizing/line receiver counter

When using sampling mode, the counter can be used as a differential counter. In totalizing counter mode, the value is sampled at fixed time intervals as in normal up/down counter operation. In differential counter mode, the difference with the count at the previous sampling time is sampled. A totalizing counter or differential counter can be setup for each channel.

Totalizing counter mode



Line receiver counter mode

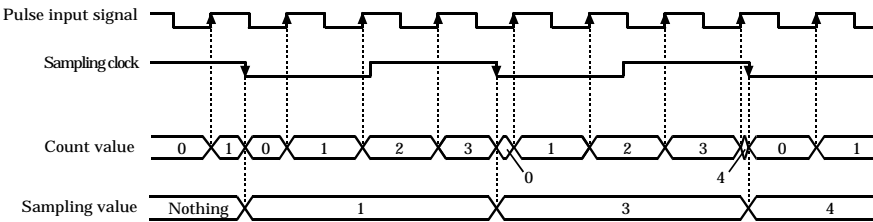

Figure 4.12. Totalizing/line receiver counter

Sampling function

Sampling function

The sampling function obtains count data periodically using the internal or external clock.

The sampling data is transferred to the PC's memory using bus master transfer. The sampling speed can be up to 20MHz using the internal clock (for 1ch). As bus master transfer is used, an error occurs and transfer halts if the CNT32-4MT(CB) cannot obtain bus access in time for a transfer. Note that whether or not continuous transfer at 20MHz is possible depends on factors such as what other applications are running on the PC.

The CNT32-4MT(CB) can perform sampling at various different timings based on the start condition, clock condition, and stop condition combination. See the "Sampling Control" section later in this manual for details of how to setup the sampling conditions.

Bus mastering

The bus master transfer function on the CNT32-4MT(CB) performs DMA transfer between the PC Card and the application's memory space by utilizing times when the bus is idle. Use a standard variable declaration in your program to define a static area to use as the application's memory space. As application memory space is defined by a logical address in operating systems such as Windows, the area may not be continuous in the physical address space. However, the CNT32-4MT(CB) can still perform continuous data transfer to such discontinuous physical address spaces. Bus master transfer can transfer data to physical address spaces up to 64Mbytes. When setting up the transfer area in your application, note that the actual available memory size depends on the operating system you are using and on the size of memory installed on the PC.

The bus master transfer function can transfer data to memory as a one-time transfer or as a ring (cyclic) transfer. For a one-time transfer, the transfer halts when the end of the specified memory area is reached. For ring transfer, transfer starts again from the start of the specified memory area when the end of the memory area is reached. The transfer continues until the stop condition is detected or the transfer is halted by software.

Interrupt (During bus mastering)

The following interrupt features are available during bus mastering:

- Generating an interrupt upon completion of transfer of the specified number of data items
- Generating an interrupt upon completion of transfer

These interrupts can be passed to the application using the "API-CNT(98/PC)" routines in API-PAC(W32).

If transfer halts due to an error such as not being able to obtain bus access in time to perform a transfer, the CNT32-4MT(CB) halts the transfer and generates the transfer completion interrupt. Whether or not an error has occurred can be determined by checking the status.

Status, Count

The following types of status (error) are available concerning bus mastering.

Table 4.4. Status about bus master (Error)

Status	Description
BUS MASTER STOP	Indicates that bus mastering transfer has completed.
CNT START	Indicates that counter sampling has been started.
CNT STOP	Indicates that counter sampling has been stoped.
TRIGGER IN	Indicates that the external start signal has been received.
OVER RUN	Indicates that the external start signal has been received at least twice. Transfer continues normally.

Error	Description
FIFO FULL	Indicates that FIFO memory has been full. This is mainly because a heavy load on the system prevented bus mastering from being executed in time. Take appropriate action, for example, lower the transfer rate or system load.
S/G OVER IN	Indicates a buffer overflow. The number of data items to be transferred exceeds the buffer size. Increase the buffer size.
TRG ERROR	Indicates that the external start and stop signals have been received. Transfer is not performed when this status is set. Check how the external start and stop signals are input.
CLOCK ERROR	Indicates that, during data input/output at an external clock pulse, the next clock pulse was received. If this status is set, consider lowering the external clock frequency.

These status can be obtained by using the relevant API-CNT(98/PC) function in API-PAC(W32).

The 32-bit or 64-bit transfer count can be obtained by using the relevant API-CNT(98/PC) function in API-PAC(W32). The transfer count is obtained as the number of data items (per channel) which have been transferred to the memory area for the user application.

Control of a sampling

The CNT32-4MT(CB) can use a sampling clock to collect sampling data at fixed time intervals. The sampling clocks, sampling start triggers, and sampling stop triggers are listed below.

Table 4.5. Sampling clock / start / stop

Item	Factor	Description	Note
Sampling clock	Not used	Sampling is not used.	Set for counter mode.
	Internal clock	Internal clock(50nsec to 107sec) 25nsec unit	
	External clock	Fall of external sampling clock input (EXTCLK) (Maximum frequency response of 10 MHz)	
Sampling start trigger	Not used	Sampling is not used.	Set for counter mode.
	Software	Software command	
	Rise of an external signal	Rise of external sampling start signal (EXTSTART)	
	Fall of an external signal	Fall of external sampling start signal (EXTSTART)	
	Count match	When the count value for channel 0 to 3 matches the value in comparison register 0 or 1	
Sampling stop trigger	Not used	Sampling is not used.	Set for counter mode.
	Software	Software command	
	Rise of an external signal	Rise of external sampling stop signal (EXTSTOP)	
	Fall of an external signal	Fall of external sampling stop signal (EXTSTOP)	
	Count match	When the count value for channel 0 to 3 matches the value in comparison register 0 or 1	
	Specified number of times	Terminated after sampling for the specified number of times	
	Bus master error	When FIFO memory has become full	

- Sampling can be controlled by one clock, start, and stop trigger per PC Card. One sampling start trigger per PC Card and one sampling stop trigger per PC Card are available. Triggering on the rising or falling edge can be selected.
- The first sampling data is collected when a sampling start trigger is input (not synchronized with the sampling clock). Collection of the second and subsequent sampling data is synchronized with the sampling clock. Note that this means that the time between the first and second samples may be less than the specified sampling clock period.
- Sampling halts immediately when the sampling stop trigger is input. No sampling data is collected at or after the time when sampling stops.
- Although the sampling clock can be set as fast as 50nsec, this is for sampling of one channel only. If the number of sampled channels is greater, the minimum sampling clock period becomes the number of sampling channels x 50nsec.
Example: Minimum sampling clock for 4-channel sampling = 4 x 50 nsec = 200 nsec

Hardware event

Types of hardware events

The PC Card includes functions that can operate automatically in response to a change in a control input signal, control output signal, or counter match. These are called hardware events.

One control input signal line and one control output signal line are provided for each channel.

Table 4.6. Hardware event

Item	Purpose	Condition
Control input signal *1	Preset	Rise(Low → High)
		Fall(High → Low)
	Zero-clear	Rise(Low → High)
		Fall(High → Low)
	Counter start/stop	Rise(Low → High)
		Fall(High → Low)
Control output signal *2	Count match(Register 0)	Count value = Comparison register 0
	Count match(Register 1)	Count value = Comparison register 1
	Abnormal input error	When phases-A and B are changed at the same time
	Digital filter error	When a pulse faster than the digital filter setting is input
Count match	Preset	Count value = Comparison register 0
		Count value = Comparison register 1
	Zero clear	Count value = Comparison register 0
		Count value = Comparison register 1

*1: When the control input signal is used as a general-purpose input, hardware events cannot be set as above.

*2: When the above control output signals are set as hardware events, the output consists of a one-shot pulse output. The pulse width can be set by software to 10μsec, 1msec, 10msec, or 100msec. When using the control output signal as a general-purpose output, the output becomes a level output and the above hardware events cannot be assigned. The logic polarity of the output signal can be set by software.

Control input signal

One control input signal is provided for each channel. The control input signal can serve for one of the following applications. The application is software-selectable.

Table 4.7. Control input signal

Item	Purpose	Condition
Control input signal	General-purpose input	Software status(positive logic)
	Preset	Rise(Low → High)
		Fall(High → Low)
	Zero-clear	Rise(Low → High)
		Fall(High → Low)
	Counter start/stop	Rise(Low → High)
Fall(High → Low)		

General-purpose input

When not used for a hardware event, the control input pin can be used as the general-purpose input signal pin. The input logic is fixed as positive logic.

Preset

When the control input signal is set to presetting, the control input pin serves as the external trigger input pin for presetting. The rising or falling edge of the signal can be selected.

Zero-clear

When the control input signal is set to zero-clearing, the control input pin serves as the external trigger input pin for zero-clearing. The rising or falling edge of the signal can be selected.

A counter start/stop

When the control input signal is set to counter start/stop, the control input pin serves as the external trigger input pin for counter start/stop. The rising or falling edge of the signal can be selected for each of the counter start and counter stop.

Control output signal

One control output signal is provided for each channel. Each output signal can be used as a general-purpose output (level output) or as a one-shot pulse output for sending notification of hardware events to an external device.

Although all hardware events can be set to trigger a one-shot pulse output, in this case there is no way to determine which event caused the one-shot pulse to be output and therefore the status needs to be checked or similar.

The output polarity is set by software.

Table 4.8. Control output signal

Item	Purpose	Condition	Note
Control output signal	General-purpose output	Software command	Level output (Positive logic/Negative logic)
	Count match(Register 0)	Count value = Comparison register 0	A one shot pulse is outputted. (Positive logic/Negative logic) *
	Count match(Register 1)	Count value = Comparison register 1	
	Abnormal input error	When phases-A and B are changed at the same time	
	Digital filter error	When a pulse faster than the digital filter setting is input	

* The one-shot pulse width is set by software to 10 μ sec, 100 μ sec, 1 msec, 10 msec, or 100 msec.

General-purpose output

When not used as a hardware event, the control output pin can be used as a general-purpose output. In this case, the output becomes a level output rather than a one-shot pulse output. The logic polarity can be switched between positive and negative.

Count match (Register 0)

A one-shot pulse is output to indicate a count match (register 0) output when the count matches the value set in compare register 0. The logic polarity can be switched between positive and negative.

Count match (Register 1)

A one-shot pulse is output to indicate a count match (register 1) output when the count matches the value set in compare register 1. The logic polarity can be switched between positive and negative.

Abnormal input error

A one-shot pulse is output to indicate an abnormal input error when the A and B phases change simultaneously. The logic polarity can be switched between positive and negative.

Digital filter error

A one-shot pulse is output to indicate a digital filter error if a pulse faster than the digital filter time setting is input. The logic polarity can be switched between positive and negative.

Count match

Functions are provided to generate an interrupt, externally output a one-shot pulse, preset the counter value, or clear the counter to zero when the count matches the value in compare register 0 or compare register 1.

The PC Card has two compare registers for each channel used to compare the count value. If two or more registers are required, use software to update the register values. Having two compare registers available allows upper and lower limits to be set.

Table 4.9. Count match

Item	Factor	Function
Count match	Count value = Comparison register 0 or Count value = Comparison register 1	Interrupt
		One-shot pulse output
		Preset
		Zero-clear

Given below are application examples using the count match feature.

<Example 1> Move count values 100 to 200 in both ways. When the count value falls below 90 or exceeds 210, a one-shot pulse is output to an external device.

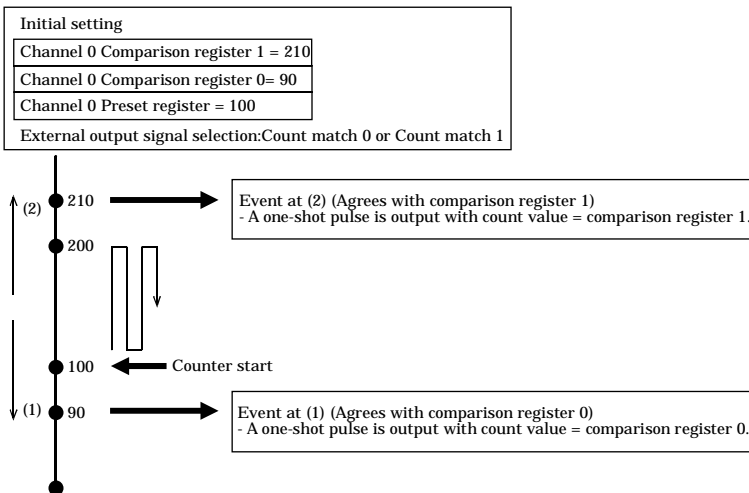

Figure 4.13. Example 1

<Example 2> Start sampling with a count value of 500 and stop it with a count value of 1000.

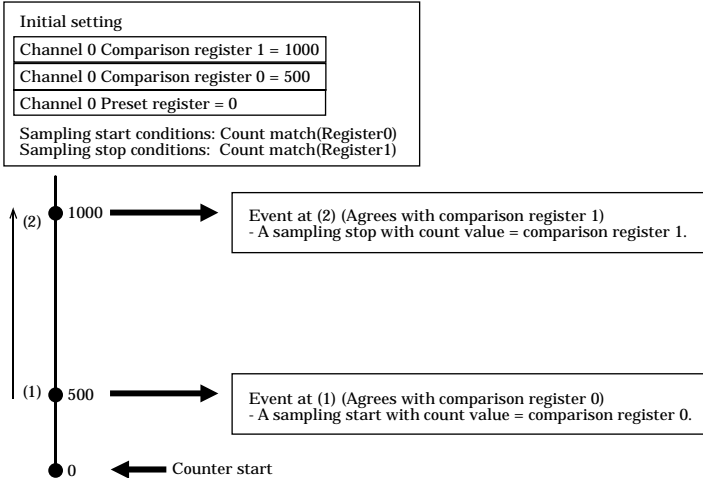

Figure 4.14. Example 2

<Example 3> Set comparison values of 100, 200, 300, 400, 500, ... and generate interrupts in sequence.

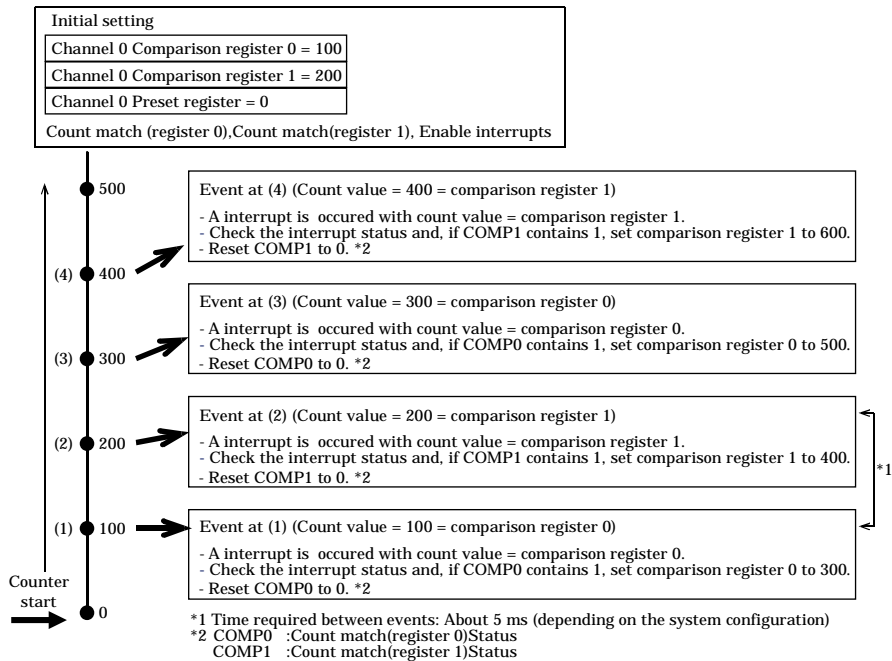

Figure 4.15. Example 3

Counter error

Counter errors are classified into two types: digital filter error and abnormal input error.

Digital filter error

A digital filter error occurs when a signal faster than the digital filter setting is input to phase A or phase B. Notification of the error is via a status (latch/clear), interrupt, or external output (one-shot pulse).

The card monitors the input signal level for digital filter errors using the filter source clock which has a period of 1/2 the setting value. The digital filter error is detected when the same level cannot be detected for two or more consecutive times.

However, a filter error does not occur if the frequency of the input clock is equal to or close to an integer multiple of the filter source clock.

The following are possible causes for a digital filter error.

- When a signal faster than the digital filter setting is input
- Noise is generated.

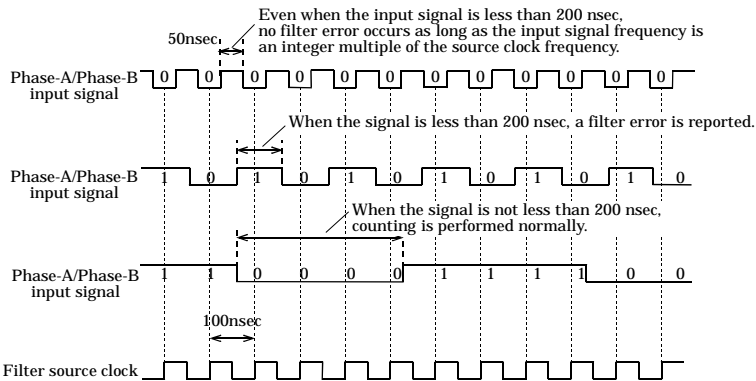

Figure 4.16. Filter error (Set to 0.2 μ sec)

Abnormal input error

An abnormal input error occurs when the counter input signal changes on the A and B phases simultaneously. Notification of the error is via a status (latch/clear), interrupt, or external output (one-shot pulse). If the digital filter is enabled, an abnormal input error occurs when both the A and B phases change during one period of the digital filter source clock. When the filter is disabled, an abnormal input error occurs when both the A and B phases change during one period of the PC Card's 40MHz (25nsec) reference clock.

A possible cause of the abnormal input error is as follows.

- When the phase difference between phases-A and B is shorter than one digital filter source clock cycle (25 nsec with no filter set)
- Noise is generated.

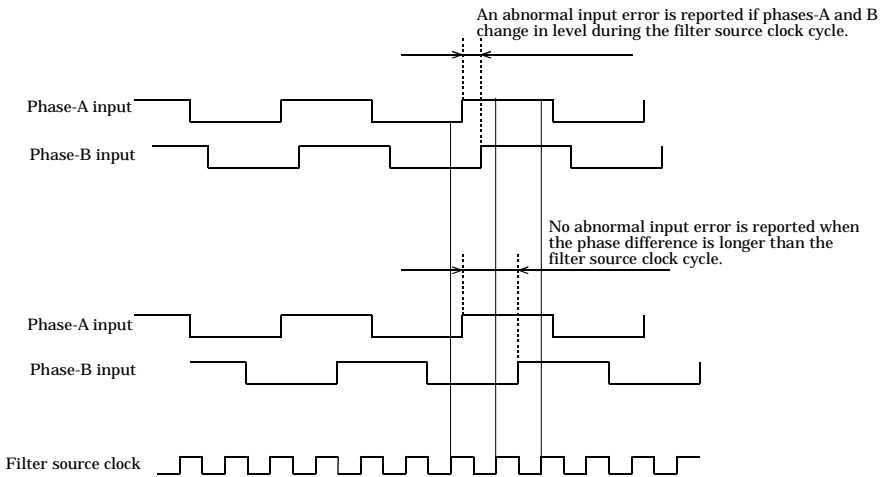

Figure 4.17. Abnormal input error

Sampling output signal

The start, stop, or clock signals used to control sampling on the CNT32-4MT(CB) can be output from the interface connector.

Sampling start output signal

This outputs the sampling start trigger as a one-shot pulse signal (100nsec) with negative logic polarity. The logic polarity and pulse width cannot be modified.

Sampling stop output signal

This outputs the sampling stop trigger as a one-shot pulse signal (100nsec) with negative logic polarity. The logic polarity and pulse width cannot be modified.

Sampling clock output signal

This outputs the sampling clock trigger as a one-shot pulse signal (100nsec) with negative logic polarity. The logic polarity and pulse width cannot be modified.

Status input

The CNT32-4MT(CB) has the following status.

Pulse signal input states

The phase-A, phase-B, and phase-Z input states and count directions can be checked by their status.

Control input signal states

The control input signal states can be checked by the status.

Error

Abnormal input error

An abnormal input error occurs when the counter input signal changes on the A and B phases simultaneously. A status is latched to indicate that this error has occurred and can be cleared by software.

Digital filter error

When a signal faster than the digital filter setting is input to phase-A or B, it is reported as a digital filter error. The status is latched and cleared by software.

Carry/Borrow

Carry

The 32-bit counter is set to [1] when incremented from its maximum value FFFFFFFFh to 0h.

Borrow

The counter is set to [1] when decremented from 0H to FFFFFFFFh.

Count match

A count match (to register 0), count match (to register 1), incremental count match, or decremental count match for each channel can be checked by the status.

Other functions

Digital filter

The digital filter is provided so that the counter works normally even when the pulse input to the counter, phase-A/B/Z signal, or control input signal has noise. When the digital filter detects the High (or Low) level maintained for the digital filter setting time, it outputs “High” (or “Low”) to the counter circuit. The setting range is set by software to “unused” or 0.1 μ sec to 1.6384 msec.

Note that, since all of these digital signals are input to the internal counter through the digital filter, a delay of the set time is required for them to be input when the digital filter is used.

Initially, the delay owing to the digital filter does not occur as it is not used by default.

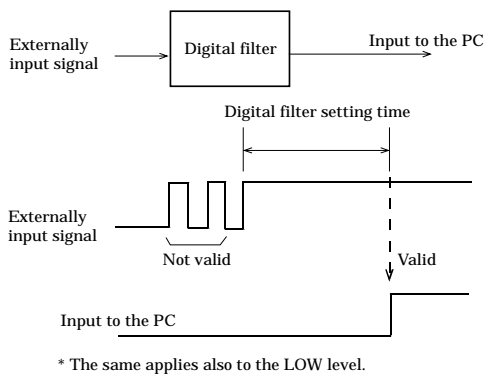

Figure 4.18. Digital filter



CAUTION

- The digital filter is initially disabled. (It remains disabled when left untouched.)
- The delay may be longer than the set time depending on the noise included.
- If the level changes at a frequency shorter than the set time, the level change is ignored and the input is not counted correctly.

Timer

The timer can generate an interrupt at software-set intervals. The setting range is 1 to 6553 msec (in 1 ms increments).

5. About Software

The bundled CD-ROM “Driver library API-PAC(W32)” contains the functions that provide the following features:

- Function to read the current count value of a specified channel
- Function to read the current status register for a specified channel
- Function to prevent chattering based on a digital filter using hardware capabilities
- Function to preset or zero-clear the counter at the rising or falling edge of the control input signal
- Function to output a one-shot pulse to the control output signal upon detection of a count match or error
- Function to sample count values using bus mastering in sync with the specified external clock or internal clock

For details, refer to the help file. The help file provides various items of information such as “Function Reference”, “Sample Programs”, and “FAQs”. Use them for program development and troubleshooting.

Accessing the Help File

- (1) Click on the [Start] button on the Windows taskbar.
- (2) From the Start Menu, select “Programs” – “CONTEC API-PAC(W32)” – “CNT” – “API-CNT HELP” to display help information.

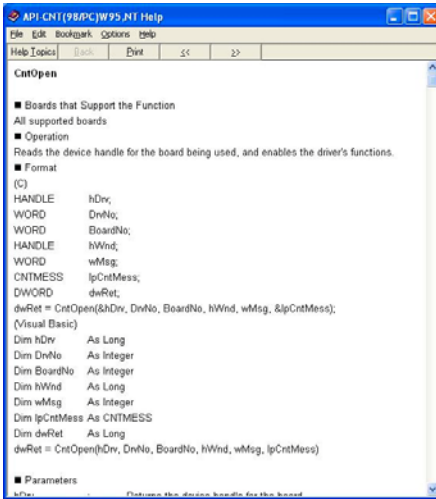
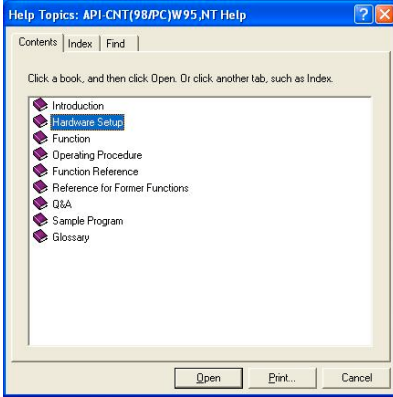

Using Sample Programs

Sample programs have been prepared for specific basic applications.

To use each sample program, enter its device name set by API-TOOL Configuration.

Use these sample programs as references for program development and operation check.

The sample programs are stored in \Program Files\CONTEC\API-PAC(W32)\Cnt\Samples or \Program Files\CONTEC\API-PAC(W32)\Cnt\Samples\CntMaster(Sample program for CNT32-8M(PCI)/CNT32-4MT(CB)).

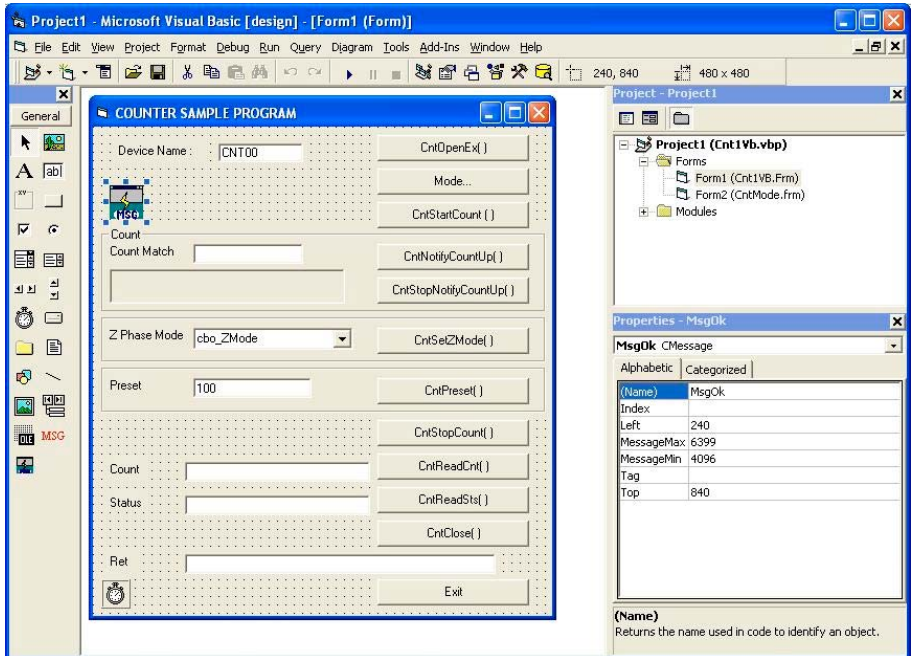

Sample Programs - Examples

- Counter Sample : Execute basic operations such as input signal count processing and hardware event handling for four channels.
- Sampling Sample : Samples pulse signals at four channels, saves the resulting data to a text file, and displays it along with the sampling status.

[Counter Sample]

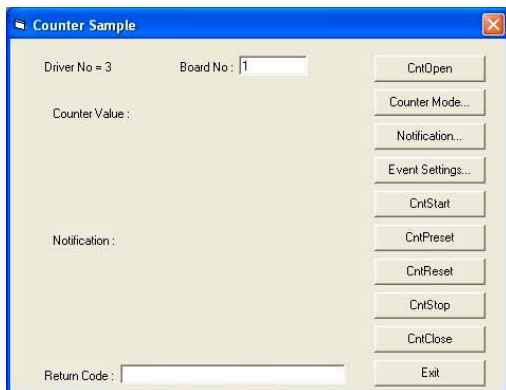

Uninstalling the API Function Libraries

To uninstall API-PAC(W32), follow the procedure below.

- (1) Click on the [Start] button on the Windows taskbar. From the Start Menu, select “Settings” – “Control Panel”.
- (2) Double-click on “Add/Remove Programs” in the Control Panel.
- (3) Select “CONTEC API-CNT(98/PC)xx” and then click on [Add/Remove] button. Follow the on-screen instructions to uninstall the function libraries.

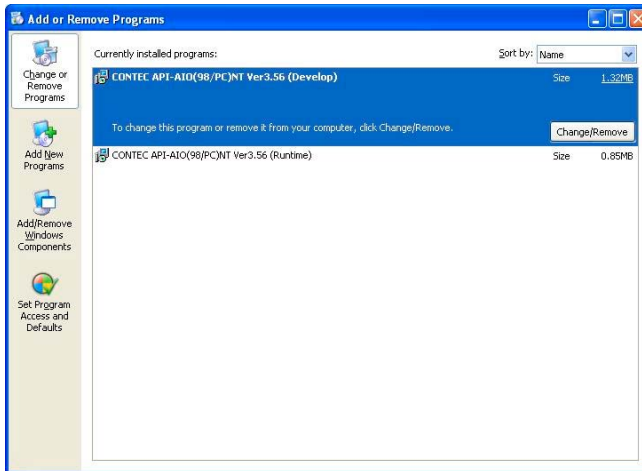

CD-ROM Directory Structure

```
\
| Autorun.exe           Installer Main Window
| Readmej.htm          Version information on each API-TOOL(Japanese)
| Readmeu.htm          Version information on each API-TOOL(English)
| - APIPAC
| | - AIOWDM
| | | - Disk 1
| | | - Disk 2
| | | - .....
| | | - Disk N
| | - CNT
| | - .....
| - FreeSamples        Sample programs in Delphi and Builder
| | - Builder 1.0
| | - .....
| - HELP              HELP file
| | - Aio
| | - Cnt
| | - .....
| - INF               OS-specific INF file folder(Windows 9X, 2000)
| | - WDM
| | - Win2000
| | - Win95
| - Linux             Linux file driver
| - Readme            Driver readme file folder
| - Release           Driver file(For creation of a user-specific install program)
| | - API_NT
| | - API_W95
```

6. About Hardware

This chapter provides hardware specifications and hardware-related supplementary information.

Hardware specification

Tables 6.1 list the hardware specifications of the PC Card.

Table 6.1. CNT32-4MT(CB) < 1 / 2 >

Item	Specification
Input	
Counter	
Channel count	4 channels
Count system	Up/down counting (2-phase/Single-phase/Single-phase Input with Gate Control Attached)
Max. count	FFFFFFFFh(binary data, 32Bit)
Input type	Unisolated LVTTTL level input
Input signal	Phase-A/UP 1 x 4 channels Phase-B/DOWN 1 x 4 channels Phase-Z/CLR 1 x 4 channels
Response frequency	10MHz 50% duty
Digital filter	0.1μsec to 1.6384msec or not used (can be independently set for each channel.)
Timer	1msec to 6553msec 1msec unit
Counter start trigger	Software/External start input/Sampling start trigger
Counter stop trigger	Software/External stop input/Sampling stop trigger
Sampling	
Sampling start trigger	Software/External start input/Count match
Sampling stop trigger	Software/External stop input/Specification number/Bus master transfer error/Count match
Sampling clock	Sampling timer/External clock input
Sampling timer	50nsec to 107sec 25nsec unit(can not be independently set for each channel.)
External sampling start signal	Unisolated LVTTTL level input (Select Rise or Fall)
External sampling stop signal	Unisolated LVTTTL level input (Select Rise or Fall)
External sampling clock signal	Unisolated LVTTTL level input (Fall)
Response frequency	10MHz 50% duty
Control	
Control input signal type	Unisolated LVTTTL level input
Control input channel	1 x 4 channels
Control input signal	- Preset(Select Rise or Fall) - Zero-clear(Select Rise or Fall) - Counter start/stop(Select Rise or Fall) - General-purpose input(positive logic) Software-selected from among the above four options
Response time	100nsec (Max.)
Interrupt event	Count match(8 points), Counter error(2 points), Sampling factor(6 points), Carry/Borrow(1 points), Timer(1 points)

Table 6.1. CNT32-4MT(CB) < 2 / 2 >

Item	Specification
Output	
Control	
Control output signal type	Unisolated LVTTTL level output
Control output channel	1 x 4 channels
Control output signal	- Count match 0 output(one-shot pulse output) - Count match 1 output(one-shot pulse output) - Digital filter error output(one-shot pulse output) - Abnormal input error output(one-shot pulse output) - General-purpose output(Level output) Software-selected from among the above five options (Positive/negative logic is selected with the software.)
One shot output signal amplitude	Selected between 10 μ sec, 100 μ sec, 1msec, 10msec and 100 msec (Can be set for each channel, within precision + 1 μ sec)
Response time	100nsec (Max.)
Rated output current	I _{OL} =8mA(Max.) I _{OH} =-8mA(Max.)
Test pulse	
Test pulse output signal type	Unisolated LVTTTL level output
Test pulse output point	One for each of phases-A and B
Output frequency	100kHz fixed
Sampling	
Sampling output signal type	Unisolated LVTTTL level output
Output point	Sampling start trigger, sampling stop trigger, Sampling clock trigger 1 point each
One-shot output signal width	Negative logic 100nsec (fixed)
Response speed	100nsec (Max.)
Rated output current	I _{OL} = 8mA(Max.) I _{OH} = -8mA(Max.)
Bus master	
DMA channel	1 channel
Transfer bus width	32-Bit width
Transfer data length	8 PCI Words length(Max.)
Transfer rate	80MB/sec(Max.133MB/sec)
FIFO	1K-DWord
Scatter/Gather function	64MB
Interrupt event	Bus master event(7 points)
Common	
I/O address	Occupies 2 locations, any 32-bytets and 64-byte boundary
Power consumption	3.3VDC, 300mA (Max.)
Operating condition	0 to 50°C, 10 to 90%RH (No condensation)
Supported PC Card slot	PC Card Standard CardBus
Dimension (mm)	85.6(W) x 54.0(D) x 5.0(H) TYPE II *1
Weight	50g

*1 If a PC has two TYPE II size PC card slots arranged vertically, you cannot mount CNT32-4MT(CB) cards in both slots at once. This is due to the shape of the cable connectors.

Block Diagram

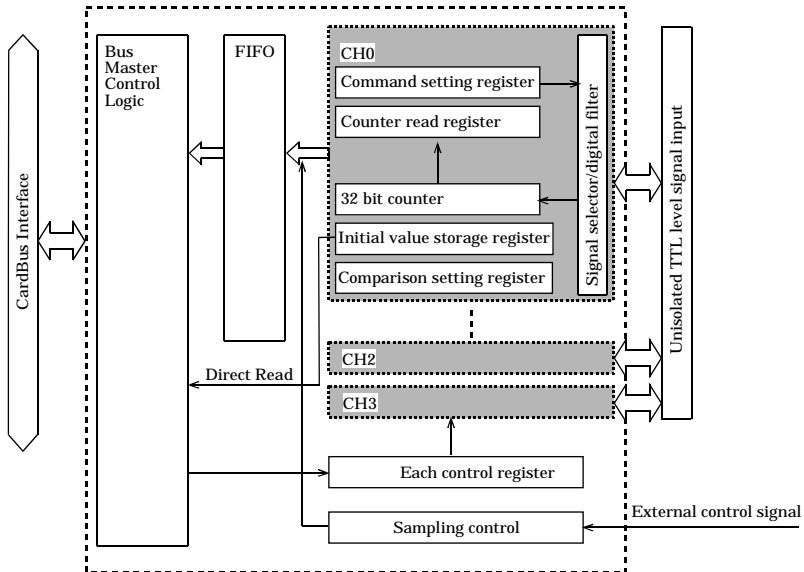

Figure 6.1. Block Diagram

CNT32-4MT(CB)

User's Guide

CONTEC CO., LTD.

June 2007 Edition

3-9-31, Himesato, Nishiyodogawa-ku, Osaka 555-0025, Japan

Japanese <http://www.contec.co.jp/>

English <http://www.contec.com/>

Chinese <http://www.contec.com.cn/>

No part of this document may be copied or reproduced in any form by any means without prior written consent of CONTEC CO., LTD. [06132007]

[12092004]

Management No. A-46-951

[06132007_rev2]

Parts No. LYEH572