

Digital Output Board with Opto-Isolation for PCI  
**PO-64L(PCI)H**



\* Specifications, color and design of the products are subject to change without notice.

**Features**

**Opto-coupler isolated open-collector output (current sink type)**  
 PO-64L(PCI)H has the 64ch of opto-coupler isolated open-collector output (current sink type) whose response speed is 200µsec. Common terminal provided per 16channels, capable of supporting a different external power supply. Supporting driver voltages of 12 - 24 VDC for I/O.

**Opto-coupler bus isolation**  
 As the PC is isolated from the input and output interfaces by opto-couplers, this product has excellent noise performance.

**Windows/Linux compatible driver libraries are attached.**  
 Using the attached driver library API-PAC(W32) makes it possible to create applications of Windows/Linux. In addition, a diagnostic program by which the operations of hardware can be checked is provided.

**The output circuit, has a built-in Zener diode and the overcurrent protection circuit of the surge voltage protection.**  
 Zener diodes are connected to the output circuits to protect against surge voltages. In addition, the output circuit, it attaches the overcurrent protection circuit at the output 8-channel unit. The output rating is max. 35VDC, 100mA per channel.

**LabVIEW is supported by a plug-in of dedicated library.**  
 Using the dedicated library makes it possible to make a LabVIEW application.

**Packing List**

- Product [PO-64L(PCI)H] ...1
- First step guide ... 1
- Disk \*1 [API-PAC(W32)] ...1
- Warranty Certificate ...1
- Serial number Label ...1

\*1 The bundled disk contains the driver software and User's Guide

This product is a PCI bus-compliant interface board used to provide a digital signal output function on a PC.  
 This product can input and output digital signals at 12 - 24VDC.

PO-64L(PCI)H features 64 opto-coupler isolated open-collector outputs. In addition, output transistor protection circuit (surge voltage protection and overcurrent protection).

Windows/Linux driver is bundled with this product.

Possible to be used as a data recording device for LabVIEW, with dedicated libraries.

- \*The contents in this document are subject to change without notice.
- \*Visit the CONTEC website to check the latest details in the document.
- \*The information in the data sheets is as of May, 2018.

**Hardware specifications**

Item	Specifications	
<b>Output</b>		
Output format	Opto-coupler isolated open-collector output (current sink type)(Negative logic *1)	
Number of output signal channels	64 channels(One common power supply per 16 channels)	
Output rating	Output voltage	35VDC (Max.)
	Output current	100mA (par channel) (Max. )
Residual voltage with output on	0.5V or less (Output current≤50mA), 1.0V or less (Output current≤100mA)	
Surge protector	Zener diode RD47FM(NEC) or equivalent	
Response time	200µsec within	
<b>Common</b>		
I/O address	Any 32-byte boundary	
Interruption level	Not used	
Max. board count for connection	16 boards including the master board	
Dielectric strength	500Vrms	
External circuit power supply	12 - 24VDC (±10%)	
Power consumption	5VDC 250mA (Max)	
Operating condition	0 - 50°C, 10 - 90%RH(No condensation)	
Allowable distance of signal extension	Approx. 50m (depending on wiring environment)	
PCI bus specification	32bit, 33MHz, Universal key shapes supported *2	
Dimension (mm)	176.41(L)x 105.68(H)	
Weight	215g	
Standard	VCCI Class A, CE Marking (EMC Directive Class A, RoHS Directive)	

\*1 Data "0" and "1" correspond to the High and Low levels, respectively.  
 \*2 This board requires power supply at +5 V from an expansion slot (it does not work on a machine with a +3.3-V power supply alone).

**Board Dimensions**

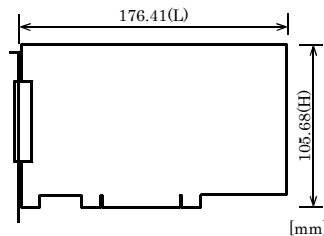

The standard outside dimension (L) is the distance from the end of the board to the outer surface of the slot cover.

## Support Software

### Windows version of digital I/O driver API-DIO(WDM)/API-DIO(98/PC) [Stored on the bundled disk driver library API-PAC(W32)]

The API-DIO(WDM) is the Windows version driver library software that provides products in the form of Win32 API functions (DLL). Various sample programs such as Visual Basic and Visual C++, etc and diagnostic program \*1useful for checking operation is provided.

For more details on the supported OS, applicable language and new information, please visit the CONTEC's Web site.

### Linux version of digital I/O driver API-DIO(LNX) [Stored on the bundled disk driver library API-PAC(W32)]

The API-DIO(LNX) is the Linux version driver software which provides device drivers (modules) by shared library and kernel version. Various sample programs of gcc are provided.

For more details on the supported OS, applicable language and new information, please visit the CONTEC's Web site.

### LabVIEW-support data acquisition library DAQfast for LabVIEW (Available for downloading (free of charge) from the CONTEC web site.)

This is a data collection library to use in the LabVIEW by National Instruments. With Polymorphic VI, our design enables a LabVIEW user to operate seamlessly. Our aim is that the customers to perform easily, promptly what they wish to do.

For more details on the library and download of DAQfast for LabVIEW, please visit the CONTEC's Web site.

### Data acquisition library for LabVIEW VI-DAQ (Available for downloading (free of charge) from the CONTEC web site.)

This is a VI library to use in National Instruments LabVIEW. VI-DAQ is created with a function form similar to that of LabVIEW's Data Acquisition VI, allowing you to use various devices without complicated settings.

For more details on the library and download of VI-DAQ, please visit the CONTEC's Web site.

## Cable & Connector (Option)

96-Pin Shield Cable with a Half-Pitch Connector  
: PCB96PS-0.5P (0.5m), PCB96PS-1.5P (1.5m),  
PCB96PS-5P (5m)

Flat Cable with 96-Pin Half-Pitch Connectors at Both Ends  
: PCB96P-1.5 (1.5m), PCB96P-3 (3m)

96-Pin Shield Cable with 2Sided Half-Pitch Connector  
: PCA96PS-0.5P (0.5m), PCA96PS-1.5P (1.5m),  
PCA96PS-3P (3m), PCA96PS-5P (5m)

Flat Cable with One 96-Pin Half-Pitch Connector  
: PCA96P-1.5 (1.5m), PCA96P-3 (3m)

Connection Conversion Shield Cable(96P → 37P x 2)  
: PCB96WS-1.5P (1.5m), PCB96WS-3P (3m),  
PCB96WS-5P (5m)

## Accessories (Option)

Screw Terminal (M3 x 96P) : EPD-96A \*1\*4

Screw Terminal (M3.5 x 96P) : EPD-96 \*1

Digital I/O 64CH Series Terminal Panel (M3 x 96P)  
: DTP-64A \*1

Signal Monitor for Digital I/O (64Bits)  
: CM-64 L \*1

Screw Terminal (M3 x 37P) : EPD-37A \*2\*4

Screw Terminal (M3.5 x 37P) : EPD-37 \*2

General Purpose Terminal (M3 x 37P) : DTP-3A \*2

Screw Terminal (M2.5 x 37P) : DTP-4C \*2

Signal Monitor for Digital I/O (32Bits) : CM-32 L \*2

Connection Conversion Board (96-P→37-P x 2) : CCB-96 \*3

\*1 PCB96P or PCB96PS optional cable is required separately.

\*2 PCB96WS optional cable is required separately.

\*3 Option cable PCB96P or PCB96PS, and the cable for 37-pin D-SUB are required separately.

\*4 "Spring-up" type terminal is used to prevent terminal screws from falling off

\* Check the CONTEC's Web site for more information on these options.

## How to connect the connectors

### Connector shape

The on-board interface connector (CN1) is used when connecting this product and the external devices.

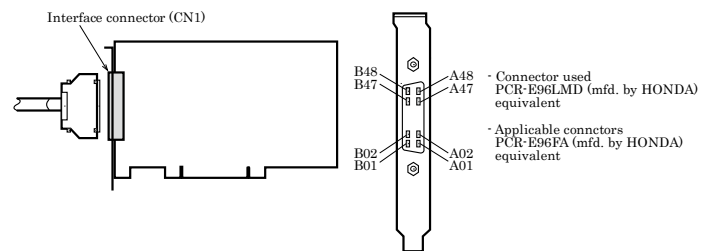

### Connector Pin Assignment

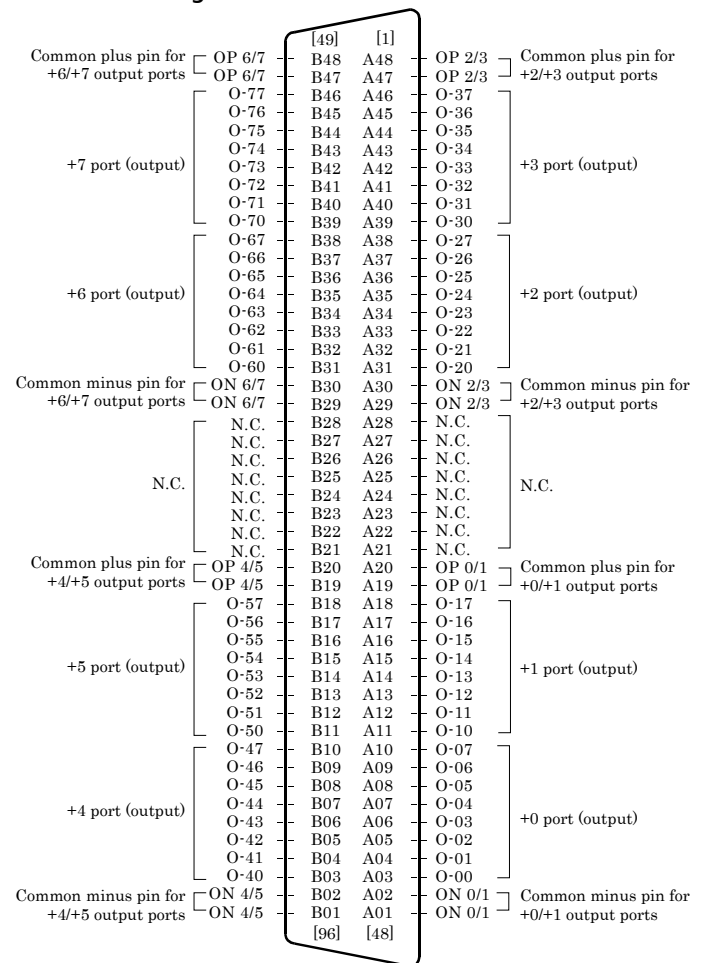

The numbers in square brackets [ ] are pin numbers designated by HONDA TSUSHIN KOGYO CO., LTD.

O-00 - O-77	64 output signal pins. Connect input signals from the external device to these pins.
OP 0/1 - OP 6/7	Connect the positive side of the external power supply. These pins are common to 16 output signal pins.
ON 0/1 - ON	Connect the negative side of the external power supply. These pins are common to 16 output signal pins.
N.C.	This pin is left unconnected.

## Output Circuit

Connect the output signals to a current-driven controlled device such as a relay or LED.

The connection requires an external power supply to feed currents. The board controls turning on/off the current-driven controlled device using a digital value.

### Output Circuit

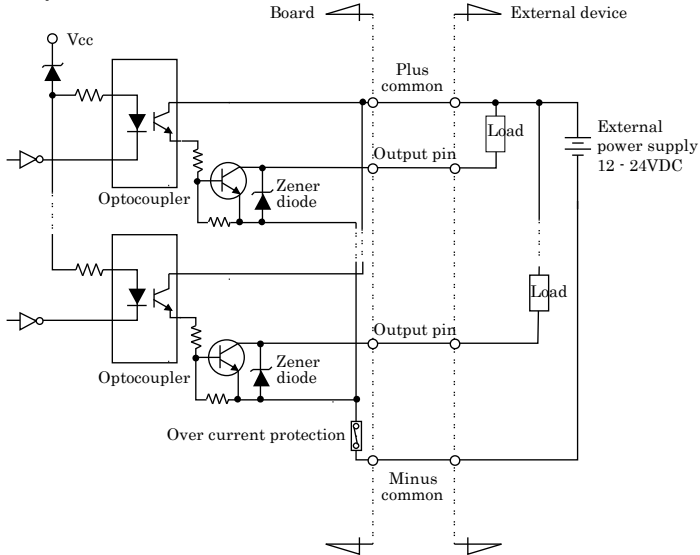

The output circuits of interface blocks of the PO-64L(PCI)H is illustrated in Figure. The signal output section is an opto-coupler isolated, open-collector output (current sink type). Driving the output section requires an external power supply.

The rated output current per channel is 100 mA at maximum. The output section can also be connected to a TTL level input as it uses a low-saturated transistor for output. The residual voltage (low-level voltage) between the collector and emitter with the output on is 0.5 V or less at an output current within 50 mA or at most 1.0 V at an output current within 100 mA.

To protect against surge voltage, a Zener diode is connected to the output transistor. Also, an overcurrent protection circuit is attached to a unit of eight output channels.

### ⚠ CAUTION

When the PC is turned on, all output are reset to OFF.

### Connection to the LED

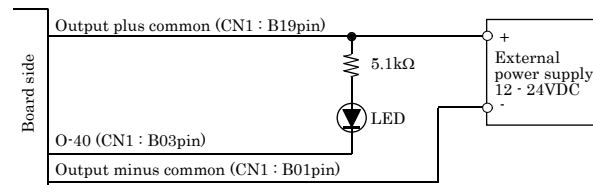

When "1" is output to a relevant bit, the corresponding LED comes on.  
When "0" is output to the bit, in contrast, the LED goes out.

### Example of Connection to TTL Level Input

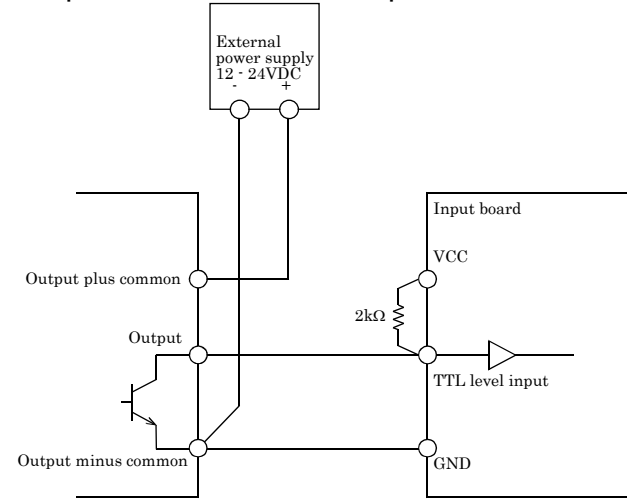

### Connecting the Sink Type Output and Sink Output Support Input

The following example shows a connection between a sink type output (output board) and a sink output support input (input board). Refer to this connection example when you connect such boards to each other.

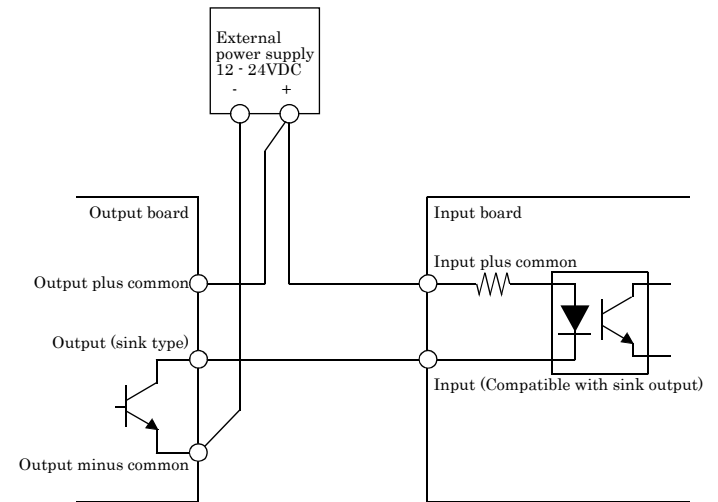

## Block Diagram

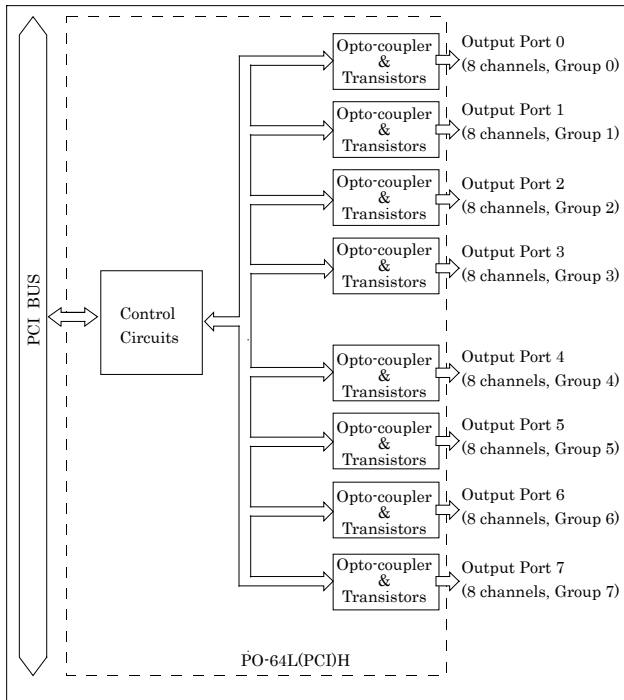

## Differences between the PO-64L(PCI)H and PO-64L(PCI)

The PO-64L(PCI)H is connector-pin compatible with the conventional PO-64L(PCI) but has the following differences from it:

- (1) Protective elements provided for outputs
  - PO-64L(PCI)H : Surge protector: Zener diode
  - PO-64L(PCI) : Nothing
- (2) Different in interrupt level resource allocation
  - PO-64L(PCI)H : Automatically allocates on interrupt level.
  - PO-64L(PCI) : Uses a jumper switch to select whether to allocate interrupt levels.